

---

---

**Thermoplastics pipes for the conveyance  
of fluids — Determination of resistance  
to rapid crack propagation (RCP) —  
Small-scale steady-state test (S4 test)**

*Tubes en matières thermoplastiques pour le transport des fluides —  
Détermination de la résistance à la propagation rapide de la fissure  
(RCP) — Essai à petite échelle à état constant (essai S4)*



**PDF disclaimer**

This PDF file may contain embedded typefaces. In accordance with Adobe's licensing policy, this file may be printed or viewed but shall not be edited unless the typefaces which are embedded are licensed to and installed on the computer performing the editing. In downloading this file, parties accept therein the responsibility of not infringing Adobe's licensing policy. The ISO Central Secretariat accepts no liability in this area.

Adobe is a trademark of Adobe Systems Incorporated.

Details of the software products used to create this PDF file can be found in the General Info relative to the file; the PDF-creation parameters were optimized for printing. Every care has been taken to ensure that the file is suitable for use by ISO member bodies. In the unlikely event that a problem relating to it is found, please inform the Central Secretariat at the address given below.



**COPYRIGHT PROTECTED DOCUMENT**

© ISO 2008

All rights reserved. Unless otherwise specified, no part of this publication may be reproduced or utilized in any form or by any means, electronic or mechanical, including photocopying and microfilm, without permission in writing from either ISO at the address below or ISO's member body in the country of the requester.

ISO copyright office  
Case postale 56 • CH-1211 Geneva 20  
Tel. + 41 22 749 01 11  
Fax + 41 22 749 09 47  
E-mail [copyright@iso.org](mailto:copyright@iso.org)  
Web [www.iso.org](http://www.iso.org)

Published in Switzerland

# Contents

Page

Foreword.....	iv
<b>1 Scope .....</b>	<b>1</b>
<b>2 Normative references .....</b>	<b>1</b>
<b>3 Terms and definitions.....</b>	<b>1</b>
<b>4 Symbols and abbreviated terms .....</b>	<b>1</b>
<b>5 Principle.....</b>	<b>2</b>
<b>6 Test parameters .....</b>	<b>2</b>
<b>7 Apparatus .....</b>	<b>3</b>
<b>7.1 General.....</b>	<b>3</b>
<b>7.2 Containment cage.....</b>	<b>3</b>
<b>7.3 Gauge length.....</b>	<b>3</b>
<b>7.4 Decompression baffles .....</b>	<b>4</b>
<b>7.5 Crack-initiation equipment .....</b>	<b>4</b>
<b>7.6 End caps .....</b>	<b>4</b>
<b>8 Test pieces .....</b>	<b>5</b>
<b>9 Conditioning.....</b>	<b>5</b>
<b>10 Test procedure .....</b>	<b>5</b>
<b>11 Interpretation of results.....</b>	<b>5</b>
<b>12 Test report .....</b>	<b>6</b>
<b>Annex A (normative) Determination of critical pressure (or hoop stress).....</b>	<b>7</b>
<b>Annex B (normative) Determination of critical temperature.....</b>	<b>11</b>
<b>Annex C (informative) Critical pressure correlation between S4 and full-scale tests for PE pipes .....</b>	<b>12</b>
<b>Annex D (informative) Fluid decompression and effect on RCP — Theoretical analysis .....</b>	<b>13</b>
<b>Bibliography .....</b>	<b>15</b>

## Foreword

ISO (the International Organization for Standardization) is a worldwide federation of national standards bodies (ISO member bodies). The work of preparing International Standards is normally carried out through ISO technical committees. Each member body interested in a subject for which a technical committee has been established has the right to be represented on that committee. International organizations, governmental and non-governmental, in liaison with ISO, also take part in the work. ISO collaborates closely with the International Electrotechnical Commission (IEC) on all matters of electrotechnical standardization.

International Standards are drafted in accordance with the rules given in the ISO/IEC Directives, Part 2.

The main task of technical committees is to prepare International Standards. Draft International Standards adopted by the technical committees are circulated to the member bodies for voting. Publication as an International Standard requires approval by at least 75 % of the member bodies casting a vote.

Attention is drawn to the possibility that some of the elements of this document may be the subject of patent rights. ISO shall not be held responsible for identifying any or all such patent rights.

ISO 13477 was prepared by Technical Committee ISO/TC 138, *Plastics pipes, fittings and valves for the transport of fluids*, Subcommittee SC 5, *General properties of pipes, fittings and valves of plastic materials and their accessories — Test methods and basic specifications*.

This second edition cancels and replaces the first edition (ISO 13477:1997), which has been technically revised.

# Thermoplastics pipes for the conveyance of fluids — Determination of resistance to rapid crack propagation (RCP) — Small-scale steady-state test (S4 test)

## 1 Scope

This International Standard specifies a small-scale (S4) test method for determining the arrest or propagation of a crack initiated in a thermoplastics pipe at a specified temperature and internal pressure.

This International Standard is applicable to the assessment of the performance of thermoplastics pipes intended for the supply of gases or liquids. In the latter case, air can also be present in the pipe.

NOTE This test method was developed using monolayer thermoplastics pipes. Its applicability to multi-layer/coated pipes has yet to be fully confirmed and is under study.

## 2 Normative references

The following referenced documents are indispensable for the application of this document. For dated references, only the edition cited applies. For undated references, the latest edition of the referenced document (including any amendments) applies.

ISO 161-1, *Thermoplastics pipes for the conveyance of fluids — Nominal outside diameters and nominal pressures — Part 1: Metric series*

ISO 1167-1, *Thermoplastics pipes, fittings and assemblies for the conveyance of fluids — Determination of the resistance to internal pressure — Part 1: General method*

ISO 3126, *Plastics piping systems — Plastics components — Determination of dimensions*

ISO 11922-1, *Thermoplastics pipes for the conveyance of fluids — Dimensions and tolerances — Part 1: Metric series*

## 3 Terms and definitions

For the purposes of this International Standard, the terms and definitions given in ISO 161-1 and ISO 11922-1 apply.

## 4 Symbols and abbreviated terms

$d_{i,min}$  minimum internal diameter, in millimetres, of pipe

$d_n$  nominal external diameter, in millimetres, of pipe

$e_n$  nominal wall thickness, in millimetres, of pipe

$l_c$	longitudinal crack length, in millimetres, on the outer surface of the pipe specimen, measured from the centre of the striker blade
RCP	rapid crack propagation
SDR	standard dimension ratio ( $d_n/e_n$ )
$T$	nominal test temperature, in degrees Celsius, as specified by referring standard
$T_{\text{cond}}$	conditioning temperature, in degrees Celsius, of pipe (see Clause 9)

## 5 Principle

A section of thermoplastics test pipe of specified length, conditioned to a specified test temperature and containing a fluid at a specified test pressure, is subjected to an impact near one end, designed to initiate a fast-running longitudinal crack. The crack-initiation process itself is designed so that it disturbs the test pipe as little as possible.

The test temperature and/or test pressure are as defined in the referring standard.

The fluid or mixture of fluids is identical to that used in the intended application, or is a substitute fluid which gives equivalent results. The temperature of the fluid is between the test temperature and the laboratory temperature.

Rapid decompression ahead of the propagating crack is retarded by internal baffles and by an external cage which restricts flaring of the test pipe at the edges of the fracture. Retardation of decompression maintains the crack tip stress at a level approaching that of the hoop stress in the pipe developed by internal pressure. This technique achieves steady-state RCP in a short pipe specimen at a lower pressure than that necessary to achieve propagation in the same pipe using a full-scale test (FST).

The test pipe is subsequently examined to determine whether arrest or propagation of the crack has occurred.

From a series of such tests at different pressures but at a constant temperature, the critical pressure or critical hoop stress for RCP can be determined (see Annex A).

Similarly, by testing at a series of temperatures but at a constant pressure or hoop stress, the critical temperature for RCP can be determined (see Annex B).

This test involves fracture of a pipe test piece pressurized with a compressible fluid, normally air. Therefore, the appropriate safety precautions should be taken with respect to noise and the risk of flying debris.

## 6 Test parameters

It is assumed that the following parameters will be set by the referring product standard:

- a) the diameter(s) and series of the pipe(s) to be tested;
- b) the pressurizing fluid(s), e.g. air, or air plus water and proportion;
- c) the test pressure(s);
- d) the test temperature(s), see Clause 9.

## 7 Apparatus

### 7.1 General

The apparatus shall generally comply with Figure 1, with essential features as specified in 7.2 to 7.6. The apparatus shall be located in a laboratory maintained at a temperature of no more than 25 °C.

The test should be carried out in still air to avoid significant change of the pipe surface temperature.

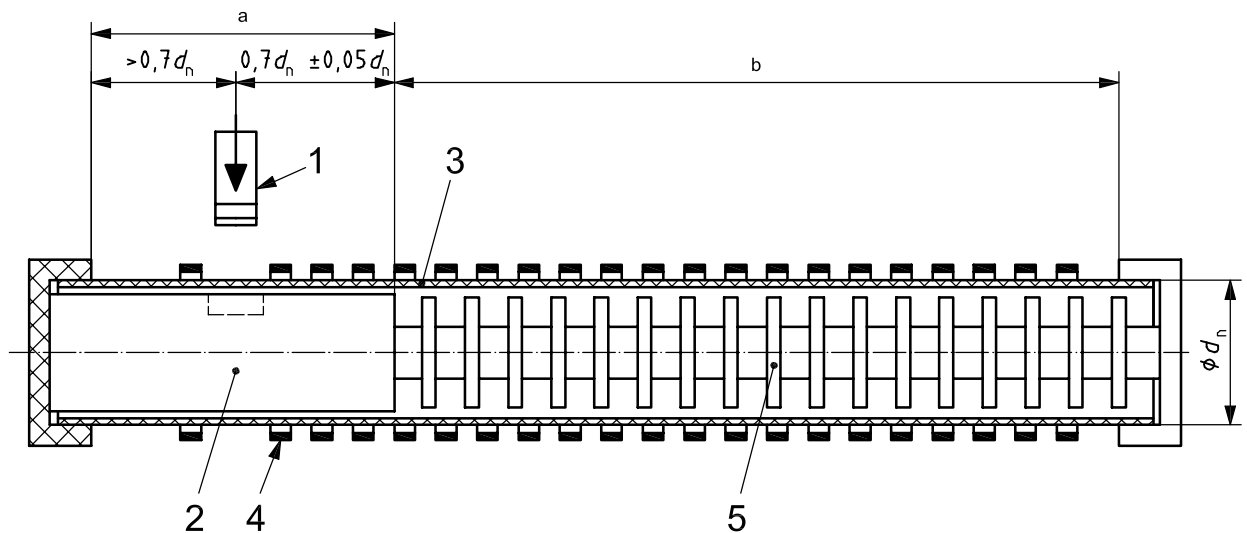

#### Key

- 1 striker blade
- 2 anvil
- 3 test pipe
- 4 containment-cage rings
- 5 decompression baffle

- a Anvil zone.
- b Gauge length ( $> 5d_n$ ).

Figure 1 — Apparatus for S4 test

### 7.2 Containment cage

The containment cage shall allow free expansion of the test pipe during pressurization, but shall restrict radial expansion during fracture to within a maximum diameter of  $(1,1 \pm 0,04)d_n$  at all points round the circumference. The cage rings shall not touch or be supported by the test pipe and shall be concentric with it.

Within the region between the crack-initiation point and the end of the gauge length, the pitch of the containment rings shall be  $(0,35 \pm 0,05)d_n$  and the longitudinal width of each ring shall be  $(0,15 \pm 0,05)d_n$ .

### 7.3 Gauge length

The gauge length shall be greater than  $5d_n$ . At least 70 % of its internal volume shall be occupied by pressurized air that can expand without restriction to drive the test pipe wall radially outwards.

Instrumentation shall be provided to measure the static pressure inside the test pipe to an accuracy of  $\pm 2$  %.

**7.4 Decompression baffles**

The decompression baffles shall be  $(0,95 \pm 0,01) d_{i,min}$  in diameter. The pitch of the baffles shall be  $0,4d_n \begin{smallmatrix} 0 \\ -0,1d_n \end{smallmatrix}$ .

Baffles should be of a material and thickness sufficient to withstand the forces expected during the test without significant distortion.

**7.5 Crack-initiation equipment**

The length of the striker-blade edge shall be  $(0,40 \pm 0,05)d_n$ . The height of the blade shall be greater than the nominal wall thickness,  $e_n$ , of the test pipe (see Figure 2).

The blade shall not penetrate more deeply than  $1e_n$  to  $1,5e_n$  from the outer surface of the test pipe and the striker shall not directly impact the outside surface of the test pipe with any point other than the blade itself. An internal anvil of circular cross-section shall ensure that the inner surface of the test pipe cannot deform, under impact of the blade, to a diameter of less than  $(0,98 \pm 0,01)d_{i,min}$  throughout the anvil zone. A slot shall be provided in the anvil to ensure that the blade is not damaged during crack initiation.

The volume of this slot shall not exceed 1 % of  $\pi d_n^3 / 4$ .

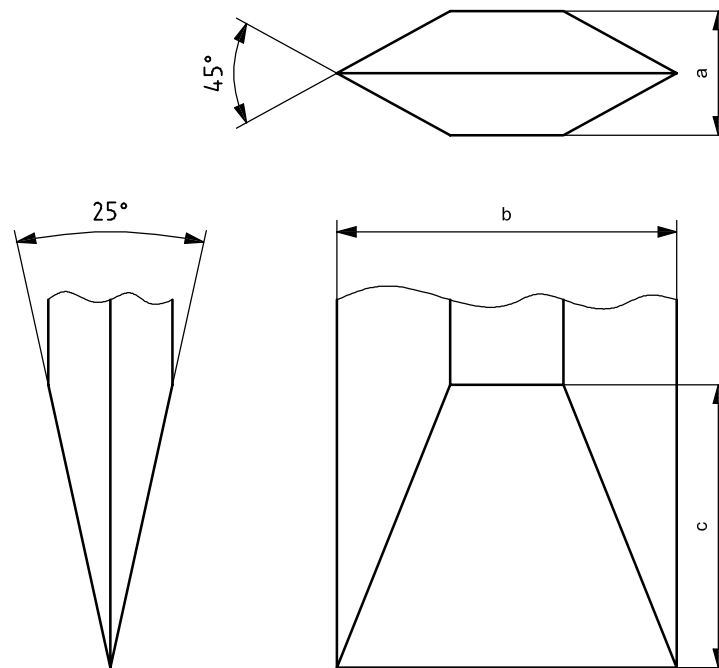

- a Thickness.
- b Length =  $(0,4 \pm 0,05)d_n$ .
- c Height  $> e_n$ .

**Figure 2 — Striker-blade geometry**

**7.6 End caps**

End caps ensuring a leaktight seal shall be fitted over each end of the test pipe.

The end caps should not introduce any additional hoop stress in the pipe.



## 8 Test pieces

The test pieces shall be straight sections of pipe of length  $l_t$ , where  $7d_n \leq l_t \leq 8d_n$ . The ends shall be square to the test pipe axes.

The test pipe surfaces along the gauge length shall not be prepared or treated in any way.

The crack-initiation end may be chamfered to facilitate fitting of the test pipe.

When difficulty is encountered in the initiation of a satisfactory crack (see 10.1) during the test, notching of the internal surface of the test pipe in the axial direction along the anvil zone may be carried out. The notch shall be positioned under the point of impact and shall not be extended into the gauge section. A razor notch of at least 1 mm depth has been found to be satisfactory in the case of polyethylene (PE) pipe.

## 9 Conditioning

The conditioning time shall be at least that according to ISO 1167-1 for the wall thickness of the pipe. The test piece shall be conditioned at a temperature,  $(T_{\text{cond}} \pm 1) ^\circ\text{C}$ , which is related to the specified test temperature,  $T$ , using Equation (1):

$$T_{\text{cond}} = 1,12T - 2,8 \quad (1)$$

For example, for a specified test temperature of  $0 ^\circ\text{C}$ , the conditioning temperature must lie between  $-3,8 ^\circ\text{C}$  and  $-1,8 ^\circ\text{C}$ .

The temperature of the pressurizing fluid shall be between the test temperature,  $T$ , and the laboratory temperature.

All reasonable precautions should be taken to ensure that the temperature of the conditioning fluid is uniform by recirculation.

## 10 Test procedure

**10.1** Crack initiation shall follow within  $(180 \pm 20)$  s of removal of the test pipe from the conditioning fluid.

**10.2** Using unpressurized pipe sections having a minimum gauge length of  $5d_n$ , establish initiation conditions to generate a crack length,  $l_c$ , of at least  $0,7d_n$ . The striker velocity shall be  $(15 \pm 5)$  m/s. If necessary, introduce a notch (see Clause 8).

**10.3** Maintain the initiation conditions established in 10.2. After removal of the test piece from the conditioning fluid, pressurize it to within  $\pm 2\%$  of the required test pressure with the specified pressurizing fluid. Record the test pressure. Perform the test and measure the crack length,  $l_c$ .

If initiation does not occur at the specified test temperature, the temperature may be reduced until initiation is demonstrated.

**NOTE** If arrest occurs in tests performed at the required test pressure but at a lower temperature than specified, it is concluded that arrest will occur at a higher temperature and at the same test pressure and higher; see Clause A.8.

## 11 Interpretation of results

Crack arrest is defined as having taken place when  $l_c < 4,7d_n$ .

Crack propagation is defined as having taken place when  $l_c \geq 4,7d_n$ .

## 12 Test report

The test report shall include the following information:

- a) reference to this International Standard (i.e. "ISO 13477") and to the referring standard;
- b) all details necessary for complete identification of the test pipe(s), including the manufacturer, the polymer used for manufacture, the production date(s) and the identification marking on the test pipe(s);
- c) nominal pipe diameter(s) and pipe series;
- d) gauge length(s);
- e) the test temperature(s) and conditioning method;
- f) test pressure(s) and pressurizing fluid, or fluids and proportions;
- g) the crack length(s),  $l_c$ ;
- h) a record of the mass and the speed of the striker;
- i) the date(s) of the test(s);
- j) details of any factors which could have affected the results, such as any incidents or any operations not specified in this International Standard.

## Annex A (normative)

### Determination of critical pressure (or hoop stress)

#### A.1 General

This method is recommended for determining, at a given temperature, the critical pressure (or hoop stress) above which a crack initiated through the wall of a thermoplastics pipe will propagate steadily along the pipe. The upper pressure limit for the test is 10 bar<sup>1)</sup>.

#### A.2 Symbols

$d_{em}$	mean outside diameter, in millimetres, of test pipe
$D$	average of the mean outside diameters, $d_{em}$ , in millimetres
$e_t$	mean wall thickness, in millimetres, of test pipe along (main) crack
$p$	test pressure, in bars
$p_{cS4}$	critical pressure, in bars
$\sigma_{cS4}$	critical hoop stress, in megapascals

#### A.3 Principle

A series of tests at various pressures but at a constant temperature is used to determine the critical pressure (or critical hoop stress) at which there is a sharp transition from abrupt arrest of an initial crack to continued steady propagation of the crack.

A single test that results in crack arrest indicates that the critical pressure for propagation is greater than the test pressure.

#### A.4 Procedure

##### A.4.1 General

Using a range of test pressures, and following the procedure in Clause 10, obtain:

- a) at least one test result with crack arrest (i.e.  $l_c < 4,7d_n$ );
- b) at least one test result with crack propagation (i.e.  $l_c \geq 4,7d_n$ ).

---

1) 1 bar = 0,1 MPa = 0,1 N/mm<sup>2</sup>.

**A.4.2 Critical hoop stress**

**A.4.2.1 Preparation**

Using a  $\pi$ -tape, measure the mean outside diameter,  $d_{em}$ , in accordance with ISO 3126, at three points along the test pipe. Calculate and record the average of these results as  $D$ .

**A.4.2.2 After testing**

Measure the wall thickness, in accordance with ISO 3126, at intervals along the test pipe adjacent to the crack path, or the main crack path if there is more than one. Record the individual wall thickness values, and calculate and record the mean value,  $e_t$ .

If a fracture is accompanied by wall thinning, carry out all the thickness measurements a sufficient distance away from the crack path.

**A.5 Analysis for determining critical pressure**

It is useful to plot a graph of crack length against test pressure (see Figure A.1). The crack length is measured from the centre of the striker.

The critical pressure,  $p_{CS4}$ , is defined as the highest measured crack-arrest pressure below the lowest measured crack-propagation pressure.

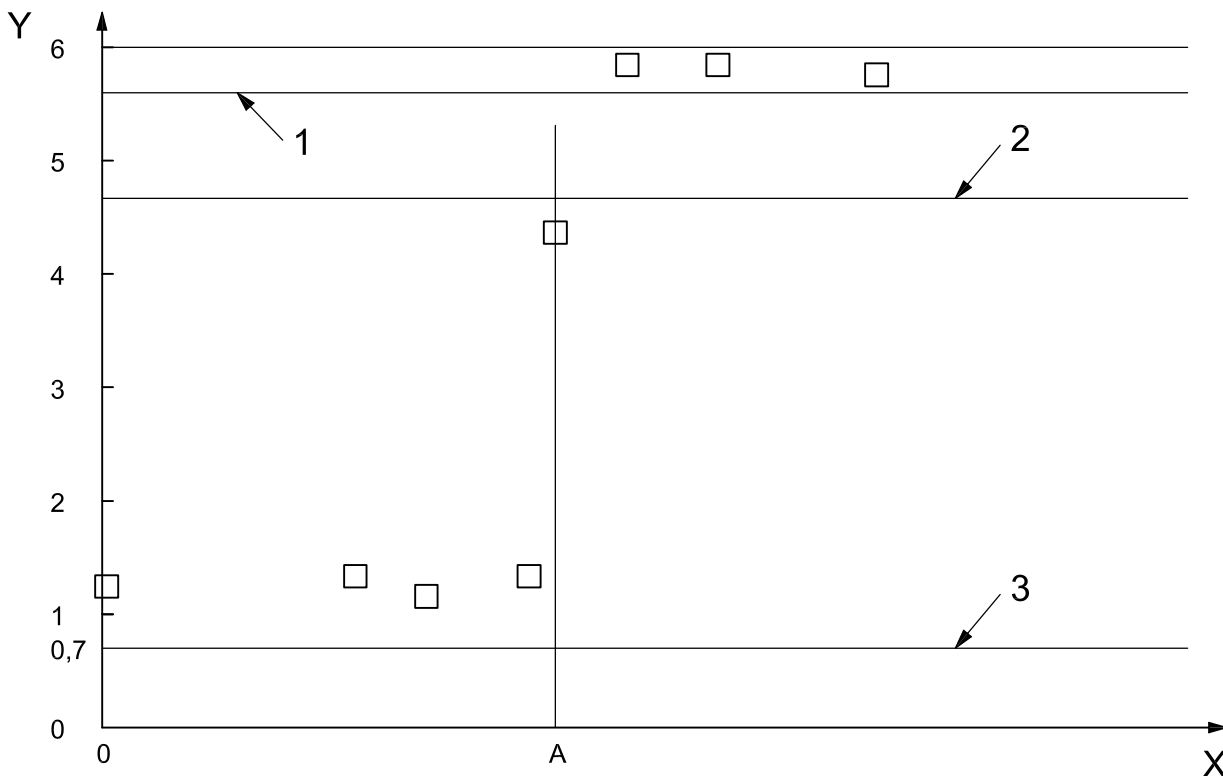

**Key**

- |   |   |   |                            |
|---|---|---|----------------------------|
| A | $p_{CS4}$ or $\sigma_{CS4}$                   | 1 | minimum gauge length       |
| X | test pressure, $p$ , or hoop stress, $\sigma$ | 2 | critical crack length      |
| Y | crack length/nominal pipe diameter, $l_c/d_n$ | 3 | minimum valid crack length |

**Figure A.1 — Typical test-data plot to determine critical pressure,  $p_{CS4}$ , or critical hoop stress,  $\sigma_{CS4}$**

## A.6 Estimation of critical pressure without crack propagation test results

A single test which results in crack arrest indicates that the critical pressure for propagation is greater than the test pressure.

To validate tests where crack arrests occur at pressures  $\geq 6$  bar, a series of tests in 2 bar increments from 6 bar upwards to a maximum of 10 bar shall be carried out.

## A.7 Analysis for determining critical hoop stress

For each test pipe, calculate the hoop stress,  $\sigma$ , in megapascals, using Equation (A.1):

$$\sigma = \frac{p(D - e_t)}{20e_t} \quad (\text{A.1})$$

where

$p$  is the test pressure, in bars;

$D$  is the average of the mean outside diameters,  $d_{em}$ , in millimetres;

$e_t$  is the mean wall thickness of the test pipe along the (main) crack, in millimetres.

Plot a graph of crack length against hoop stress (see Figure A.1).

The critical hoop stress,  $\sigma_{cS4}$ , is defined as the highest crack-arrest hoop stress below the lowest crack-propagation hoop stress (see Figure A.1).

It is recommended that the test pressures be chosen alternately above and below the expected value of  $p_{cS4}$  or  $\sigma_{cS4}$ .

## A.8 Additional information

Obtaining initiation conditions at 0 °C for PE 100 pipes and thin-walled PE 80 pipes is very difficult, if not impossible. However, initiation conditions can be obtained at lower temperatures, e.g. –15 °C, so that the crack length, at zero test pressure, is consistently greater than the  $0,7d_n$  necessary (see 10.2). The test is then conducted using these initiation conditions at the required test pressure,  $p_{S4}$ . If the crack arrests, i.e.  $l_c < 4,7d_n$ , this is a valid test and this test pressure,  $p_{S4}$ , is below the actual  $p_{cS4}$  for this low temperature (see Clause A.3). The  $p_{S4}$  can be converted into the equivalent full-scale pressure,  $p_{FS}$ , using the correlation factor (see Clause C.2).

It is also logical to assume that if arrest occurs at the full-scale pressure,  $p_{FS}$ , at a sub-zero temperature, then arrest will also occur at the same pressure  $p_{FS}$  at higher temperatures and, in particular, at 0 °C. Invariably, the resistance to RCP increases with increasing temperature.

## A.9 Test report — Additional requirements

**A.9.1** In the case of critical pressure determinations, the test report shall include the following additional information: the measured critical pressure,  $p_{cS4}$ , in bars.

**A.9.2** In the case of critical hoop stress determinations, the test report shall include the following additional information:

- a) individual wall thicknesses, in millimetres, measured along the (main) crack;
- b) mean wall thickness,  $e_t$ , in millimetres, of the test pipe along the (main) crack path;
- c) mean outside diameters,  $d_{em}$ , in millimetres, of the test pipe;
- d) the average,  $D$ , of the mean outside diameters,  $d_{em}$ , in millimetres, of the test pipe;
- e) plot of crack length,  $l_c$ , against hoop stress,  $\sigma$ ;
- f) estimated critical hoop stress,  $\sigma_{cS4}$ , in megapascals.

## Annex B (normative)

### Determination of critical temperature

A series of tests, similar to those specified in Annex A, on a particular type of thermoplastics pipe may be conducted at a constant pressure not exceeding 5 bar or an equivalent constant hoop stress, to determine the critical temperature.

This can be a useful technique, as it is almost always possible to obtain both crack-arrest and crack-propagation conditions and, therefore, the critical temperature. However, for some thermoplastics pipes, at temperatures at or above 0 °C, RCP may not be possible at any pressure and so the critical pressure cannot be determined.

The critical temperature,  $T_c$ , is defined as the lowest crack-arrest temperature above the highest crack-propagation temperature (see Figure B.1). The result which defines the lowest arrest temperature shall be validated by performing an initiation test, as specified in 10.2, at the same temperature.

A single test which results in crack arrest indicates that the critical temperature for crack propagation is lower than the test temperature.

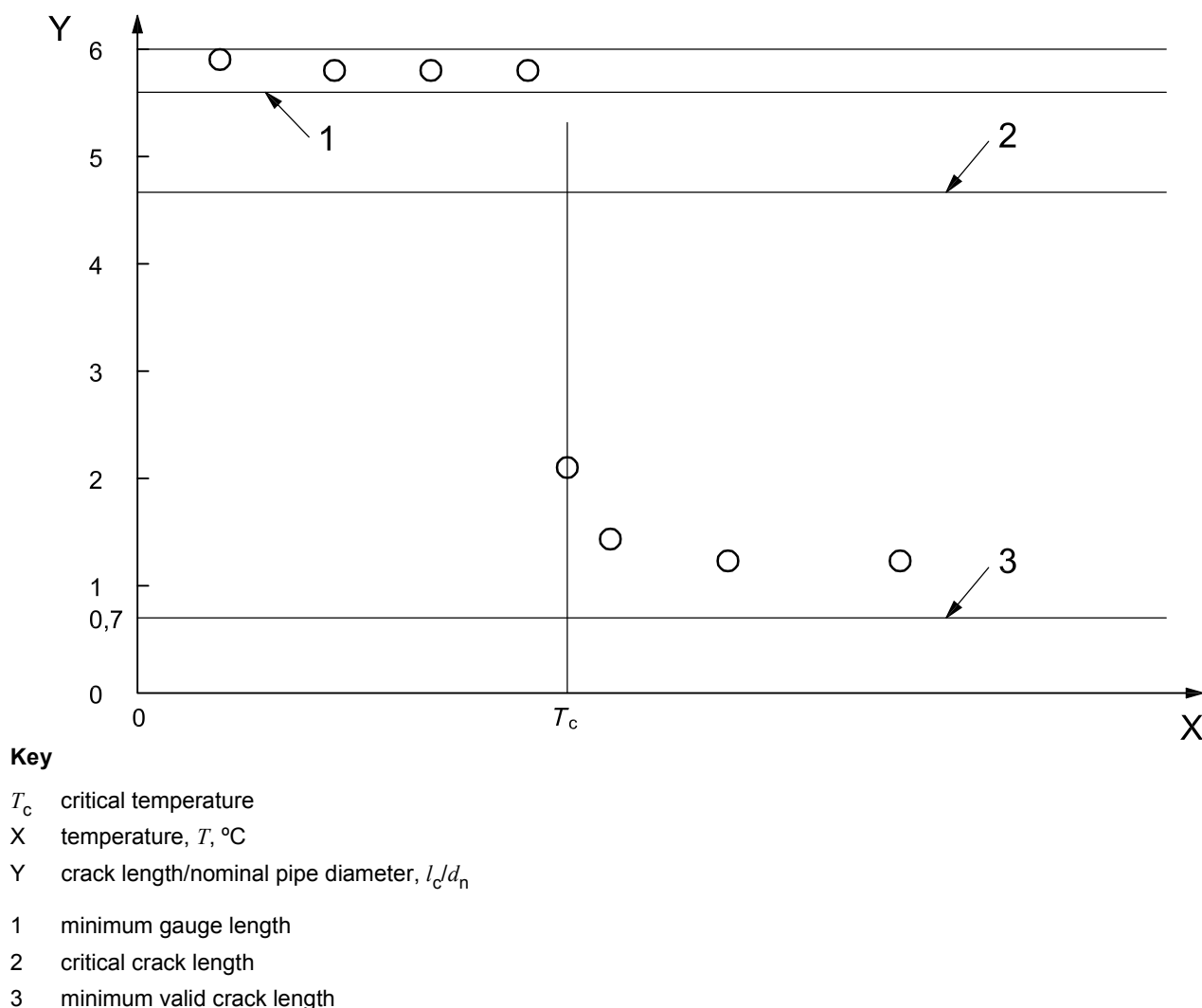

Figure B.1 — Typical test-data plot to determine critical temperature,  $T_c$

## Annex C (informative)

### Critical pressure correlation between S4 and full-scale tests for PE pipes

#### C.1 Introduction

The critical pressure measured using the S4 test method according to this International Standard is lower than that measured on the same pipe using ISO 13478 <sup>[1]</sup>, whose FST method is considered to give the reference value.

A correlation between these critical pressure results is needed, so that sufficiently consistent values of maximum operating pressure can be calculated using either method. A theoretical correlation has been proposed and is supported by experimental results, although its exact form remains the subject of ongoing research.

#### C.2 Correlation factor

The correlation between S4 and FST critical pressures, for the same pipe, is expressed by Equation (C.1):

$$\frac{p_{c,FS} + p_{atm}}{p_{c,S4} + p_{atm}} = 3,6 \quad (C.1)$$

$$p_{c,FS} + p_{atm} = 3,6(p_{c,S4} + p_{atm})$$

If atmospheric pressure,  $p_{atm} = 1$  bar, then

$$p_{c,FS} = 3,6p_{c,S4} + 2,6$$

The critical pressure,  $p_c$ , in bars, is defined as:

$$p_c = p_{c,FS} = 3,6p_{c,S4} + 2,6$$



## Annex D (informative)

### Fluid decompression and effect on RCP — Theoretical analysis

For the theoretical approach of the correlation function between the FST and S4 test, see References [4], [12] and [13].

The process of decompression due to fracture occurs in two phases (see Figure D.1). First, axial backflow follows a decompression wave which travels ahead of the propagating crack tip. The remaining pressure is then lost by transverse discharge through the crack opening.

Following the arrival of the decompression wave front at any point along the pipe, the pressure begins to decay from its initial value,  $p_0$ . The pressure at the crack tip,  $p_t$ , gradually decreases until it stabilizes when the total crack opening area becomes larger than the pipe cross section. For a constant speed,  $v$ , one dimensional gas flow analysis gives Equation (D.1):

$$\frac{p_t}{p_0} = \left\{ \left[ 1 - \frac{\gamma-1}{\gamma+1} \left( 1 - \frac{v}{c_0} \right) \right]^{\frac{2\gamma}{\gamma-1}} \right\} \quad \text{if } v < c_0 \quad (\text{D.1})$$

and Equation (D.2):

$$\frac{p_t}{p_0} = 1 \quad \text{if } v \geq c_0 \quad (\text{D.2})$$

where

$\gamma$  is the ratio of specific heat at constant pressure to specific heat at constant volume for the gas;

$c_0$  is the speed of sound in the gas.

All pressure values are absolute.

It is primarily the action of pressure on the flaring pipe wall behind the crack tip which drives the crack, and this pressure is determined by that at crack tip,  $p_t$ , rather than the initial value,  $p_0$ . In the S4 test, the decompression baffles practically eliminate axial backflow, so that the entire initial pipe pressure drives the crack, whereas in the FST only the pressure which survives axial decompression can contribute. The assumption that transverse gas discharge is similar in both tests allows the relationship between  $p_t$  and  $p_0$  in Equation (D.1) to be simply translated into  $p_{c,S4}$  and  $p_{c,FS}$  at critical conditions.

During RCP in an FST on PE pipe just above the critical pressure, the crack tip often arrests momentarily. For zero crack speed and for  $\gamma = 1,4$  (as for air and natural gas), Equation (D.1) shows that the crack tip absolute pressure,  $p_t$ , falls instantaneously to 28 % of  $p_0$ , and it can only slowly increase if RCP reinitiates. It follows that RCP can only continue in an S4 test if the absolute pressure exceeds 28 % of  $p_0$  in an FST. This leads to the factor 3,6 (=1/0,28) in the established correlation equation of Annex C. This equation is independent of pipe size, material, and fluid.

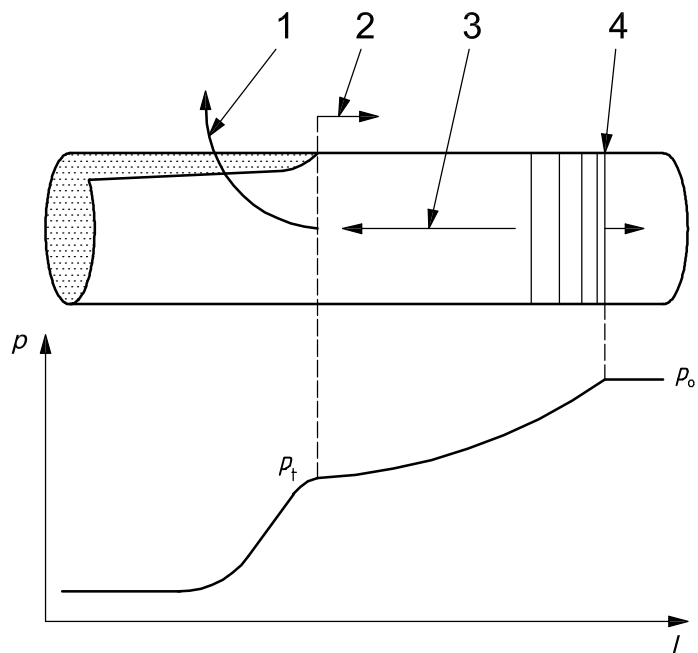

**Key**

$l$  distance  
 $p$  pressure

- 1 transverse discharge
- 2 running crack
- 3 axial back flow
- 4 decompression wave front

**Figure D.1 — Process of decompression**

## Bibliography

- [1] ISO 13478, *Thermoplastics pipes for the conveyance of fluids — Determination of resistance to rapid crack propagation (RCP) — Full-scale test (FST)*
- [2] ROBERTSON, T.S. Propagation of brittle fracture in steel. *J. Iron Steel Inst.* 1953, **175**, pp. 361-374
- [3] VANCROMBRUGGE, R. Fracture properties in plastic pipe. In: *5th International Conference Plastics Pipes*, 1982-09-08 to 10, University of York
- [4] WOLTERS, M., KETEL, G. Some experiences with the modified Robertson test used for the study of rapid crack propagation in PE-pipelines. In: *Proceedings of the 8th Plastics Fuel Gas Pipe Symposium*, November/December 1983, New Orleans, USA
- [5] GREIG, J.M. *Fracture propagation in 250 mm and 315 mm polyethylene gas pipes*. British Gas Engineering Research Station, 1985. (Report No. E472)
- [6] GREIG, J.M. Rapid crack propagation in hydrostatically pressurized 250 mm polyethylene pipe. In: *Proc. 7th International Conference Plastics Pipes*, Bath, England, September 1988, pp. 12.1-12.7
- [7] LEEVERS, P.S., VENIZELOS, G., IVANKOVIC, A. Rapid crack propagation along pressurized PE pipe: Small scale testing and numerical modelling. *Constr. Build. Mater.* 1993, **7**, pp. 179-184
- [8] VANSPEYBROECK, P. Evaluation of test methods for determining rapid crack propagation properties of pressurized polyethylene gas pipes. In: *International Conference on Pipeline Reliability*, Calgary, Alberta, June 1992
- [9] LEEVERS, P.S. Impact and dynamic fracture of tough polymers by thermal decohesion in a Dugdale zone. *Int. J. Fracture* 1995, **73**, pp. 109-127
- [10] VANSPEYBROECK, P. Test methods for determining rapid crack propagation properties of pressurized polyethylene (gas) pipes. In: *2nd International Pipeline Technology Conference*, Ostend, Belgium, 1995-09-11 to 14
- [11] BROWN, N., LU, X., INGHAM, E.J., MARSHALL, G.P. Small scale laboratory test for resistance to RCP. In: *Proc. International Symposium on Plastics Pipes*, American Gas Association, Orlando, FL, USA, 1999, pp. 10-20 to 23
- [12] GREENSHIELDS, C.J., LEEVERS, P.S. Correlation between full scale and small scale steady state (S4) tests for rapid crack propagation in plastic gas pipe. *Plast. Rubber Compos.: Macromol. Eng.* 1999, **28**, pp. 20-25
- [13] VANSPEYBROECK, P. RCP, after 25 years of debates, finally mastered by two ISO-tests. (*Proc. 11th International Conference Plastics Pipes*, 2001-09-03 to 06, Munich, Germany), pp. 557-566. Institute of Materials, London, 2001
- [14] LEEVERS, P.S., HILLMANSEN, S., MORENO, L. DE F.F. Specimen temperature conditioning and drift before an S4 pipe fracture test. *Polym. Test* 2004, **23**, pp. 727-735

