

First edition
2011-09-15

**Textile machinery and accessories —
Bars for drop wires for electrical warp
stop motions**

*Matériel pour l'industrie textile — Supports de lamelles pour
casse-chaînes électriques*



Reference number
ISO 13435:2011(E)

© ISO 2011



COPYRIGHT PROTECTED DOCUMENT

© ISO 2011

All rights reserved. Unless otherwise specified, no part of this publication may be reproduced or utilized in any form or by any means, electronic or mechanical, including photocopying and microfilm, without permission in writing from either ISO at the address below or ISO's member body in the country of the requester.

ISO copyright office
Case postale 56 • CH-1211 Geneva 20
Tel. + 41 22 749 01 11
Fax + 41 22 749 09 47
E-mail copyright@iso.org
Web www.iso.org

Published in Switzerland

Foreword

ISO (the International Organization for Standardization) is a worldwide federation of national standards bodies (ISO member bodies). The work of preparing International Standards is normally carried out through ISO technical committees. Each member body interested in a subject for which a technical committee has been established has the right to be represented on that committee. International organizations, governmental and non-governmental, in liaison with ISO, also take part in the work. ISO collaborates closely with the International Electrotechnical Commission (IEC) on all matters of electrotechnical standardization.

International Standards are drafted in accordance with the rules given in the ISO/IEC Directives, Part 2.

The main task of technical committees is to prepare International Standards. Draft International Standards adopted by the technical committees are circulated to the member bodies for voting. Publication as an International Standard requires approval by at least 75 % of the member bodies casting a vote.

Attention is drawn to the possibility that some of the elements of this document may be the subject of patent rights. ISO shall not be held responsible for identifying any or all such patent rights.

ISO 13435 was prepared by Technical Committee ISO/TC 72, *Textile machinery and accessories*, Subcommittee SC 3, *Machinery for fabric manufacturing including preparatory machinery and accessories*.

.....

Textile machinery and accessories — Bars for drop wires for electrical warp stop motions

1 Scope

This International Standard specifies dimensions and tolerances for bars for drop wires for electrical warp stop motions with continuous contact rail (form E1) or inner split contact rail (form E2).

2 Dimensions

The dimensions for bars for drop wires for electrical warp stop motions with continuous contact rail (form E1) or inner split contact rail (form E2) shown in Figure 1 and Figure 2, and given in Table 1, shall be met.

NOTE For tolerance, b , see Table 1.

2.1 Form E1

For bars for drop wires for electrical warp stop motions with continuous inner contact rail, see Figure 1.

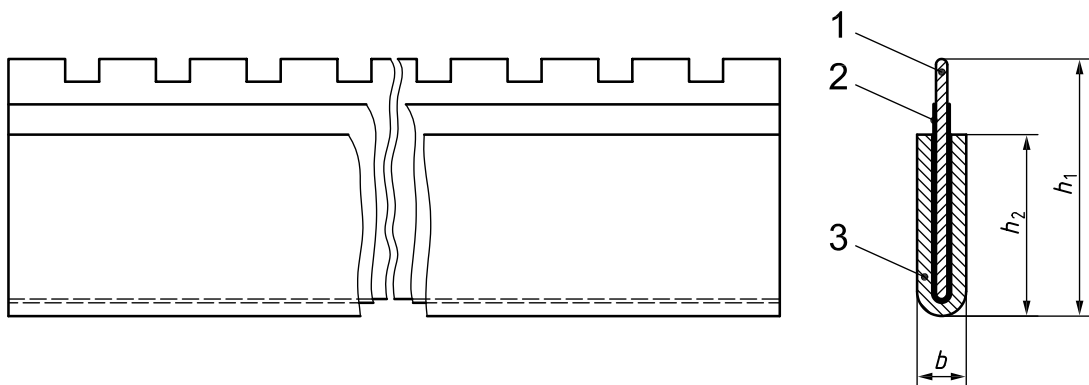

Key

- 1 inner contact rail
- 2 isolation
- 3 external contact rail

Figure 1 — Form E1 — Toothed

2.2 Form E2

For inner split contact rail for separate control of the left or right half of the weaving machine, see Figure 2.

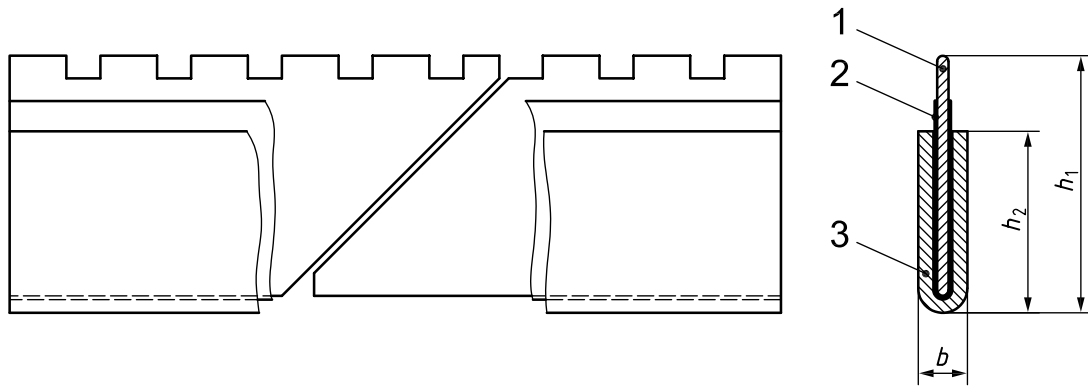

Key

- 1 inner contact rail
- 2 isolation
- 3 external contact rail

Figure 2 — Form E2 — Toothed

Table 1 — Bars for drop wire

Dimensions in millimetres

	<i>b</i>	<i>h</i> ₁	<i>h</i> ₂	Length ^a
	Tolerances			
3,4	0 -0,3	13	9	According to type of weaving machine
		18	14	
4	+0,1 -0,2	23	16	
			18	

^a The length of the bar depends on the type and width of the weaving machine and shall be given in the designation.

3 Designation for bars for drop wires for electrical warp stop motions

The designation for bars for drop wires for electrical warp stop motions with continuous contact rail (form E1) and inner split contact rail (form E2) shall include the following information in the order given:

- a) reference to this International Standard, i.e. ISO 13435:2011;
- b) type of electrical warp stop motions:
 - with continuous contact rail (form E1);
 - with inner split contact rail (form E2);
- c) width of the bar, *b*, in millimetres;
- d) height of the bar, *h*₁, in millimetres;
- e) length of the bar (according to type of weaving machine).

EXAMPLE A bar for drop wires for electrical warp stop motion with continuous inner contact rail (form E1) of width *b* = 4 mm, height *h*₁ = 23 mm and length = 1 600 mm is designated as follows:

Bar for drop wire ISO 13435 - E1 - 4 × 23 × 1 600

4 Material

4.1 External and inner contact rail

Copper-zinc alloy or steel or aluminium (according to the selection of the manufacturer).

4.2 Isolation

Thermoplastic foil shall be used for isolation.

5 Construction

The type of the inner contact rail (smooth or toothed) and the variant of rail ends shall be agreed upon by the manufacturer.

© ISO 2011. All rights reserved.

.....

ICS 59.120.30

Price based on 3 pages