**Geosynthetics — Dynamic perforation
test (cone drop test)**

*Géosynthétiques — Essai de perforation dynamique (essai par chute
d'un cône)*

13433



Reference number
ISO 13433:2006(E)

© ISO 2006

PDF disclaimer

This PDF file may contain embedded typefaces. In accordance with Adobe's licensing policy, this file may be printed or viewed but shall not be edited unless the typefaces which are embedded are licensed to and installed on the computer performing the editing. In downloading this file, parties accept therein the responsibility of not infringing Adobe's licensing policy. The ISO Central Secretariat accepts no liability in this area.

Adobe is a trademark of Adobe Systems Incorporated.

Details of the software products used to create this PDF file can be found in the General Info relative to the file; the PDF-creation parameters were optimized for printing. Every care has been taken to ensure that the file is suitable for use by ISO member bodies. In the unlikely event that a problem relating to it is found, please inform the Central Secretariat at the address given below.

© ISO 2006

All rights reserved. Unless otherwise specified, no part of this publication may be reproduced or utilized in any form or by any means, electronic or mechanical, including photocopying and microfilm, without permission in writing from either ISO at the address below or ISO's member body in the country of the requester.

ISO copyright office
Case postale 56 • CH-1211 Geneva 20
Tel. + 41 22 749 01 11
Fax + 41 22 749 09 47
E-mail copyright@iso.org
Web www.iso.org

Published in Switzerland

Contents

Page

| | |
|--|-----------|
| Foreword | iv |
| 1 Scope | 1 |
| 2 Normative references | 1 |
| 3 Terms and definitions | 1 |
| 4 Principle | 1 |
| 5 Apparatus | 2 |
| 6 Specimens | 5 |
| 6.1 Sampling | 5 |
| 6.2 Number and dimension of specimens | 5 |
| 7 Conditioning | 6 |
| 8 Procedure | 6 |
| 9 Calculation | 6 |
| 10 Test report | 6 |

Foreword

ISO (the International Organization for Standardization) is a worldwide federation of national standards bodies (ISO member bodies). The work of preparing International Standards is normally carried out through ISO technical committees. Each member body interested in a subject for which a technical committee has been established has the right to be represented on that committee. International organizations, governmental and non-governmental, in liaison with ISO, also take part in the work. ISO collaborates closely with the International Electrotechnical Commission (IEC) on all matters of electrotechnical standardization.

International Standards are drafted in accordance with the rules given in the ISO/IEC Directives, Part 2.

The main task of technical committees is to prepare International Standards. Draft International Standards adopted by the technical committees are circulated to the member bodies for voting. Publication as an International Standard requires approval by at least 75 % of the member bodies casting a vote.

Attention is drawn to the possibility that some of the elements of this document may be the subject of patent rights. ISO shall not be held responsible for identifying any or all such patent rights.

ISO 13433 was prepared by the European Committee for Standardization (CEN) Technical Committee CEN/TC 189, *Geosynthetics* in collaboration with Technical Committee ISO/TC 221, *Geosynthetics*, in accordance with the Agreement on technical cooperation between ISO and CEN (Vienna Agreement).

Geosynthetics — Dynamic perforation test (cone drop test)

1 Scope

This International Standard specifies a method to determine the resistance of geosynthetics to penetration by a steel cone dropped from a fixed height.

The degree of penetration is an indication of the behaviour of the geosynthetic when sharp stones are dropped on its surface.

The method is generally applicable to geosynthetics. However, the validity of this test for some types of products should be considered carefully, as the test principle may not be applicable.

2 Normative references

The following referenced documents are indispensable for the application of this document. For dated references, only the cited edition applies. For undated references, the latest edition of the referenced document (including any amendments) applies.

ISO 554, *Standard atmospheres for conditioning and/or testing — Specifications*

ISO 9862, *Geosynthetics — Sampling and preparation of test specimens*

ISO 10320, *Geotextiles and geotextile-related products — Identification on site*

3 Terms and definitions

For the purposes of this document, the following terms and definitions apply.

3.1

hole size

diameter of the hole made by the cone in penetrating the specimen

NOTE The hole size is measured in millimetres.

4 Principle

The specimen is clamped horizontally between two steel rings. A stainless steel cone is dropped, point first, from a distance of 500 mm onto the centre of the specimen. The degree of penetration is measured by inserting a narrow-angle graduated cone into the hole.

5 Apparatus

5.1 Clamping system.

The clamping system shall prevent slippage or cutting of the specimen during the test. An example of the clamping system and the guide block is shown in Figures 1a) and 1b).

The internal diameter of the clamping rings shall be $(150 \pm 0,5)$ mm. The surfaces should be arranged so that the distance between the inner diameter of the ring and the gripping zone (i.e. start of serration, corrugations, etc.) does not exceed 7 mm.

Dimensions in millimetres

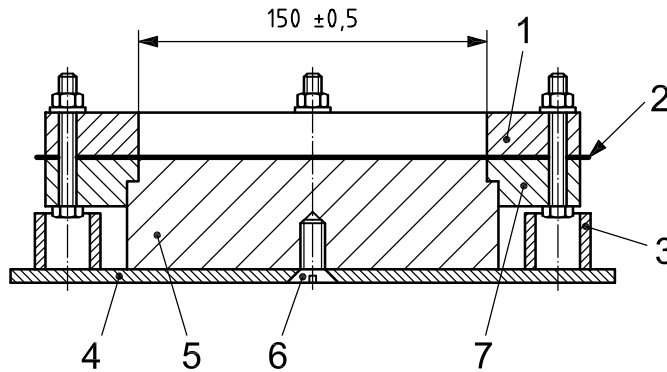

Key

- | | |
|-----------------------|-----------------------|
| 1 upper clamping ring | 5 guide block |
| 2 specimen | 6 screw |
| 3 tube | 7 lower clamping ring |
| 4 clamping aid | |

a) Example of clamping rings, guide block use

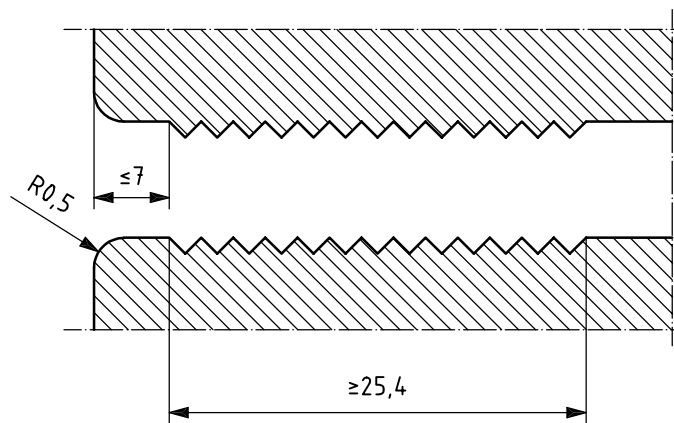

b) Example of details of serrated surfaces

Figure 1 — Examples of clamping rings and details of serrated surfaces

5.2 Frame.

The frame shall support the clamped specimen and be equipped with a means of releasing the cone onto the centre of the specimen (see Figure 2). This can be achieved either by using guides, which do not limit the rate of fall, or by an appropriate release mechanism ensuring a free fall without rotation. The frame shall be mounted on a hard, non-resilient surface.

NOTE 1 The instrument shown in Figure 2 has a safety screen to protect the operator from injury by the falling cone.

NOTE 2 It is advisable to put a shock absorbing layer on the bottom of the instrument to protect the cone in the case of total penetration.

Dimensions in millimetres

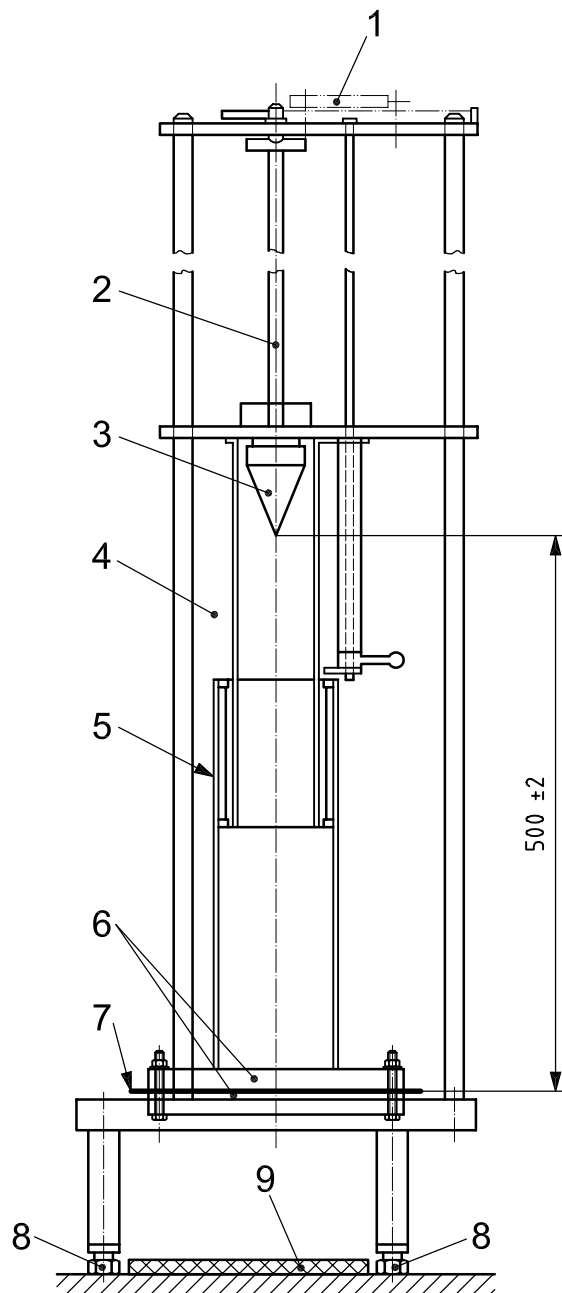

Key

- 1 head/release mechanism to suit laboratory requirements
- 2 guide rod
- 3 cone
- 4 metal screen
- 5 screen
- 6 clamping plates
- 7 specimen
- 8 levelling screw
- 9 protective layer for cone

NOTE This figure is not to scale.

Figure 2 — Typical cone drop framework with safety screen

5.3 Cone.

A stainless steel cone, with a 45° tip angle, a smooth polished surface and a mass of (1 000 ± 5) g, including the guide rod, shall be used. Detailed dimensions are shown in Figure 3.

Dimensions in millimetres

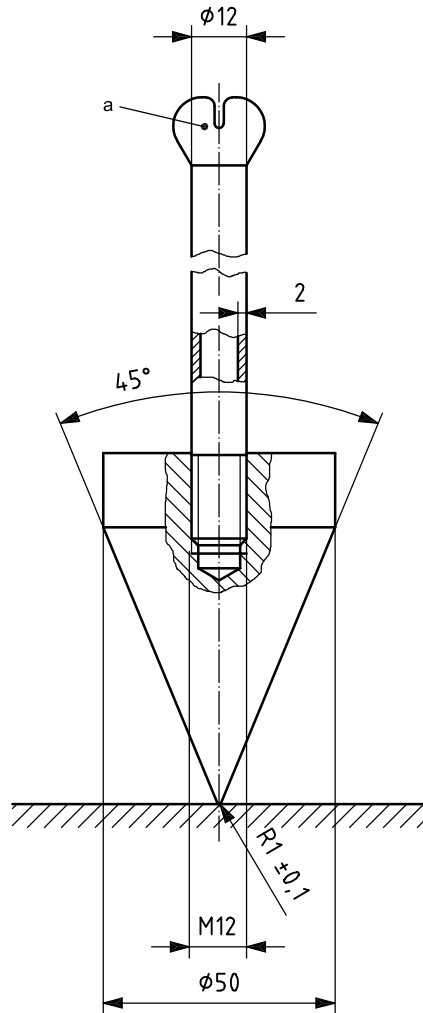

Key

^a Top to suit release mechanism and length.

NOTE This figure is not to scale.

Figure 3 — Example of cone and guide rod

5.4 Auxiliary equipment.

Means to ensure the horizontal position of the test specimen and the vertical position of the cone axis (e.g. spirit level and adjusting screws).

5.5 Measuring cone.

A graduated cone with dimensions as shown in Figure 4 and with a mass of (600 ± 5) g, including grip.

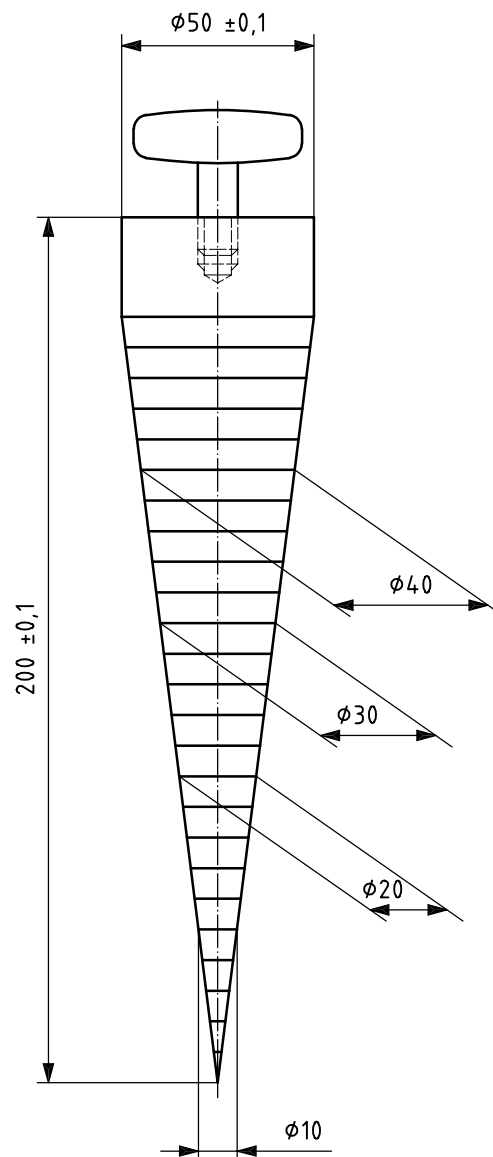

NOTE This figure is not to scale.

Figure 4 — Example of measuring cone

6 Specimens

6.1 Sampling

Take specimens in accordance with ISO 9862.

6.2 Number and dimension of specimens

Cut five specimens from the sample. Specimen dimensions shall be suitable for the apparatus used.

If the material to be tested is known to have different characteristics on the two faces (e.g. physical characteristics or as a consequence of the manufacturing process), then the complete test shall be carried out separately on each face.

7 Conditioning

The test specimens shall be conditioned in the standard atmosphere for testing at $(20 \pm 2) ^\circ\text{C}$ and $(65 \pm 5) \%$ relative humidity, as defined in ISO 554.

A specimen is considered to be conditioned when the change in mass between two successive weighings, made at intervals of not less than 2 h, does not exceed 0,25 % of the mass of the specimen.

Conditioning and/ or testing in a standard atmosphere may only be omitted when it can be shown that results obtained for the same specific type of product (both structure and polymer type) are not affected by changes in temperature and humidity exceeding the limits. This information shall be included in the test report.

8 Procedure

Ensure that the clamping rings are horizontal in the frame, using any suitable means (see 5.4).

Secure a specimen between the clamping rings free of slack (see Figure 1), e.g. by using a guide block (see Figure 2). Place the specimen and the clamping system in the testing machine.

Release the cone (5.3) so that it falls smoothly from a height of (500 ± 2) mm onto the centre of the specimen's surface.

Remove the cone and immediately place the measuring cone (5.5) carefully into the hole. Hold the measuring cone up straight, without applying any extra pressure. Wait 10 s, and then measure the diameter of the hole to the nearest millimetre. The value determined shall be the maximum visible diameter of the measuring cone when the cone is in a vertical position, viewed from underneath the specimen.

If the material has different properties in machine and cross machine direction (anisotropy), the largest visible hole diameter shall be measured.

Record the following occurrences:

- in some cases, the cone bounces off the specimen making a new hole on its second fall. In this event, measure the size of the larger hole;
- when testing woven geotextiles, it is possible that threads are shifted rather than broken. This shall be reported.

9 Calculation

Calculate the mean hole diameter and express the result in millimetres.

If the falling cone does not penetrate one or more specimens at all, or if it penetrates them totally, then the mean shall not be calculated. In this case, the individual results shall be reported, and a comment on this behaviour shall be made.

10 Test report

The test report shall specify the following:

- a) number and date of this International Standard (ISO 13433:2006);
- b) identification of the sample tested according to ISO 10320, date of receipt and date of testing;
- c) conditioning atmosphere;
- d) mean hole diameter (or individual results, see Clause 9);
- e) coefficient of variation of the hole diameter (in percent);
- f) any particular observations.

.....

ICS 59.080.70

Price based on 6 pages