**Road vehicles — Diagnostic
communication over Internet Protocol
(DoIP) —**

**Part 3:
Wired vehicle interface based on
IEEE 802.3**

*Véhicules routiers — Communication de diagnostic au travers du
protocole internet (DoIP) —*

Partie 3: Interface du véhicule câblé sur la base de l'IEEE802.3



COPYRIGHT PROTECTED DOCUMENT

© ISO 2016, Published in Switzerland

All rights reserved. Unless otherwise specified, no part of this publication may be reproduced or utilized otherwise in any form or by any means, electronic or mechanical, including photocopying, or posting on the internet or an intranet, without prior written permission. Permission can be requested from either ISO at the address below or ISO's member body in the country of the requester.

ISO copyright office
Ch. de Blandonnet 8 • CP 401
CH-1214 Vernier, Geneva, Switzerland
Tel. +41 22 749 01 11
Fax +41 22 749 09 47
copyright@iso.org
www.iso.org

Contents

Page

Foreword	iv
Introduction	v
1 Scope	1
2 Normative references	1
3 Terms and definitions	1
4 Abbreviated terms	2
5 Conventions	2
6 Document overview	2
7 Ethernet physical and data link layer requirements	3
7.1 General information	3
7.2 Ethernet physical layer requirements	4
7.3 Ethernet data link layer requirements	4
7.4 Ethernet PHY and MAC requirements	5
7.5 Ethernet activation line requirements	5
7.5.1 Vehicle activation line requirements	5
7.5.2 Vehicle activation line circuit example – Option 1 requirements	8
7.5.3 Vehicle activation line circuit example – Option 2 requirements	8
7.5.4 Principles of activation line operation	9
7.5.5 External test equipment activation line requirements	10
7.5.6 Vehicle manufacturers activation line requirements	10
7.6 Spice simulation of activation line options	10
7.7 Process to determine Options 1, 2 or non-ISO 13400	11
7.8 Cable definitions	12
Bibliography	14

Foreword

ISO (the International Organization for Standardization) is a worldwide federation of national standards bodies (ISO member bodies). The work of preparing International Standards is normally carried out through ISO technical committees. Each member body interested in a subject for which a technical committee has been established has the right to be represented on that committee. International organizations, governmental and non-governmental, in liaison with ISO, also take part in the work. ISO collaborates closely with the International Electrotechnical Commission (IEC) on all matters of electrotechnical standardization.

The procedures used to develop this document and those intended for its further maintenance are described in the ISO/IEC Directives, Part 1. In particular the different approval criteria needed for the different types of ISO documents should be noted. This document was drafted in accordance with the editorial rules of the ISO/IEC Directives, Part 2 (see www.iso.org/directives).

Attention is drawn to the possibility that some of the elements of this document may be the subject of patent rights. ISO shall not be held responsible for identifying any or all such patent rights. Details of any patent rights identified during the development of the document will be in the Introduction and/or on the ISO list of patent declarations received (see www.iso.org/patents).

Any trade name used in this document is information given for the convenience of users and does not constitute an endorsement.

For an explanation on the meaning of ISO specific terms and expressions related to conformity assessment, as well as information about ISO's adherence to the World Trade Organization (WTO) principles in the Technical Barriers to Trade (TBT) see the following URL: www.iso.org/iso/foreword.html.

The committee responsible for this document is ISO/TC 22, *Road vehicles*, Subcommittee SC 31, *Data communication*.

This second edition cancels and replaces the first edition (ISO 13400-3:2011), which has been technically revised.

A list of all parts in the ISO 13400 series can be found on the ISO website.

Introduction

Vehicle diagnostic communication has been developed starting with the introduction of the first legislated emissions-related diagnostics and has evolved over the years, now covering various use cases ranging from emission-related diagnostics to vehicle-manufacturer-specific applications like calibration or electronic component software updates.

With the introduction of new in-vehicle network communication technologies, the interface between the vehicle's electronic control units and the test equipment has been adapted several times to address the specific characteristics of each new network communication technology requiring optimized data link layer definitions and transport protocol developments in order to make the new in-vehicle networks usable for diagnostic communication.

With increasing memory size of electronic control units, the demand to update this increasing amount of software and an increasing number of functions provided by these control units, technology of the connecting network and buses has been driven to a level of complexity and speed similar to computer networks. New applications (x-by-wire, infotainment) require high band-width and real-time networks (like FlexRay, MOST), which cannot be adapted to provide the direct interface to a vehicle. This requires gateways to route and convert messages between the in-vehicle networks and the vehicle interface to test equipment.

The intent of ISO 13400 (all parts) is to describe a standardized vehicle interface which

- separates in-vehicle network technology from the external test equipment vehicle interface requirements to allow for a long-term stable external vehicle communication interface,
- utilizes existing industry standards to define a long-term stable state-of-the-art communication standard usable for legislated diagnostic communication, as well as for manufacturer-specific use cases, and
- can easily be adapted to new physical and data link layers, including wired and wireless connections, by using existing adaptation layers.

To achieve this, all parts of ISO 13400 are based on the Open Systems Interconnection (OSI) Basic Reference Model specified in ISO/IEC 7498-1 and ISO/IEC 10731, which structures communication systems into seven layers. When mapped on this model, the services specified by ISO 14229-1, ISO 14229-2 and ISO 14229-5 are divided into

- a) unified diagnostic services (layer 7), specified in ISO 14229-1, ISO 14229-5, ISO 27145-3,
 - b) presentation (layer 6):
 - 1) for enhanced diagnostics, specified by the vehicle manufacturer,
 - 2) for WWH-OBD (World-Wide Harmonized On-Board Diagnostics), specified in ISO 27145-2, SAE J1930-DA, SAE J1939-DA (SPNs), SAE J1939-73:2010, Appendix A (FMI), SAE J1979-DA, SAE J2012-DA,
 - c) session layer services (layer 5), specified in ISO 14229-2,
 - d) transport protocol (layer 4), specified in ISO 13400-2,
 - e) network layer (layer 3) services, specified in ISO 13400-2, and
 - f) physical and data link services (layers 1 and 2), specified in this document,
- in accordance with [Table 1](#).

Table 1 — Enhanced and legislated WWH-OBd diagnostic specifications applicable to the OSI layers

OSI 7 layers ^a	Vehicle manufacturer enhanced diagnostics	WWH-OBd document reference
Application (layer 7)	ISO 14229-1/ISO, 14229	ISO 14229-1/ISO, 27145
Presentation (layer 6)	Vehicle manufacturer specific	ISO 27145-2, SAE J1930-DA, SAE J1939-DA (SPNs), SAE J1939-73:2010, Appendix A (FMIs), SAE J1979-DA, SAE J2012-DA
Session (layer 5)	ISO 14229-2	ISO 14229-2
Transport (layer 4)	ISO 13400-2 DoIP TCP and IP	
Network (layer 3)		
Data link (layer 2)	ISO 13400-3 DoIP, IEEE 802.3	
Physical (layer 1)		
^a Seven layers according to ISO/IEC 7498-1 and ISO/IEC 10731.		

The application layer services covered by ISO 14229-5 have been defined in compliance with diagnostic services established in ISO 14229-1, but are not limited to use only with them.

The transport and network layer services covered by ISO 13400-2 have been defined to be independent of the physical layer implemented.

For other application areas, this document can be used with any Ethernet physical layer.

Road vehicles — Diagnostic communication over Internet Protocol (DoIP) —

Part 3: Wired vehicle interface based on IEEE 802.3

1 Scope

This document specifies the vehicle communication interface and test equipment requirements for a physical and data link layer based on IEEE 802.3 100BASE-TX.

This interface serves as the physical basis for IP-based communication between the vehicle and test equipment. This document specifies the following aspects:

- requirements for signal and wiring schematics in order to ensure physical layer compatibility of the vehicle interface and Ethernet networks and test equipment communication interfaces;
- discovery/identification of the in-vehicle diagnostic Ethernet interface;
- activation and deactivation of the in-vehicle diagnostic Ethernet interface;
- mechanical and electrical diagnostic connector requirements;
- this edition has been modified to include the identification of two Ethernet pin assignments.

2 Normative references

The following documents are referred to in the text in such a way that some or all of their content constitutes requirements of this document. For dated references, only the edition cited applies. For undated references, the latest edition of the referenced document (including any amendments) applies.

IEC 60950-1, *Information technology equipment — Safety — Part 1: General requirements*

IEEE 802.3-2015, *IEEE Standard for Ethernet*

3 Terms and definitions

For the purposes of this document, the terms and definitions given in ISO 13400-1 and ISO 14229-1 and the following apply.

3.1

automatic medium-dependent interface crossover

Auto-MDI(X)

device that allows the Ethernet hardware to decide whether a cross-linked cable or a one-to-one connected (patch) cable is used for the connection between two Ethernet ports and which configures the physical layer transceiver (PHY) according to the type of cable in order to correctly connect Tx and Rx linesterm

ISO 13400-3:2016(E)

3.2

DoIP Edge Node

host inside the vehicle, where an Ethernet activation line in accordance with this part of ISO 13400 is terminated and where the link from the first node/host in the external network is terminated

3.3

link segment

twisted-pair link for connecting two physical layers (PHYs) for 100BASE-TX

Note 1 to entry: Adapted from IEEE 802.3:2008, 1.4.355.

4 Abbreviated terms

Cat5	category 5 cable as specified in TIA/EIA-568-B ^[1]
DoIP	diagnostics over Internet Protocol
DoEth	diagnostics over Internet Protocol on Ethernet
FMI	failure mode indicator
MAC	media access control
MDI	medium-dependent interface
PE	protective earth conductor
PHY	physical layer transceiver
Rx	receive
SPN	suspect parameter number
Tx	transmit

5 Conventions

ISO 13400 is based on the conventions discussed in the OSI Service Conventions (ISO/IEC 10731) as they apply to diagnostic services.

6 Document overview

ISO 13400 is applicable to vehicle diagnostic systems implemented on an IP communication network.

ISO 13400 has been established in order to define common requirements for vehicle diagnostic systems implemented on an IP communication link.

Although primarily intended for diagnostic systems, ISO 13400 has been developed to also meet requirements from other IP-based systems needing a transport protocol and network layer services.

[Figure 1](#) illustrates the most applicable application implementations utilizing DoIP.

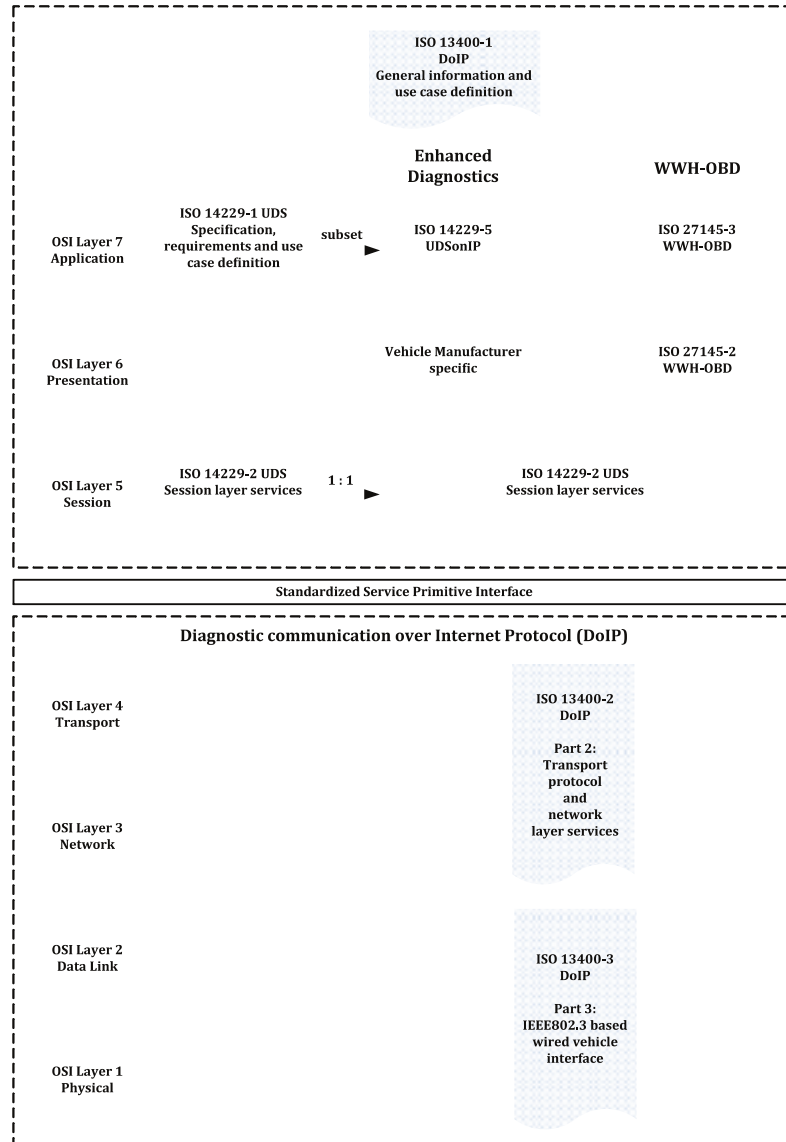

Figure 1 — DoIP document reference according to the OSI model

7 Ethernet physical and data link layer requirements

7.1 General information

Ethernet is a collection of several standards for different transmission technologies and speeds contained in IEEE 802.3 and is a frame-based networking technology for wired local area networks. Frames are defined as the format of data packets on the wire. The Internet Protocol (IPv4) theoretically allows for a maximum IP packet length of 64 Kbytes. This size is limited by the Ethernet specification, which defines a 16-bit-length field and requires a minimum packet length of 64 bytes, as well as allowing for a maximum payload length of 1 500 bytes. Consequently, IP packets can have a maximum length of only 1 500 bytes on Ethernet. However, IP allows for fragmentation of IP packets over multiple Ethernet frames to work around this limitation. The rules for fragmentation of IP packets differ between IPv6 and IPv4 and are not specified in this document.

The Ethernet connection of a vehicle works with four transmission lines in accordance with IEEE 802.3 100BASE-TX, as well as using an additional activation line. The Ethernet controller in the DoIP Edge Node can be switched on and off via the activation line when the test equipment is connected to, or disconnected from, the vehicle.

There are two types of Ethernet patch cables available:

- one-to-one (1:1) connection, which is usually used to connect an end-node (e.g. a computer) with a network hub or switch. In this case, the pins of each RJ45 connector of the patch cable or the cable to the vehicle connector are directly connected to each other (e.g. Rx+ on the source port is connected to Rx+ on the destination port).
- cross-linked connection, which is usually used to connect two end nodes directly with each other (e.g. computer to computer). In this case, the Tx pins on the source port of the patch cable are connected to the Rx pins on the destination port and vice versa.

Depending on the Auto-MDI(X) capabilities of the Ethernet implementation, it is possible that cross-linked connections or 1:1 connections can be used interchangeably. This depends on the Auto-MDI(X) capabilities of the PHY. The Auto-MDI(X) feature was developed to allow for plug and play use of both types of patch cable.

7.2 Ethernet physical layer requirements

This subclause specifies the requirements for implementation of the physical layer of Ethernet by the DoIP Edge Node, including stub length in the vehicle and maximum cable length between test equipment and the DoIP Edge Node PHY so as to allow for guaranteed operation even in noisy environments.

[DoEth-001] The DoIP Edge Node shall support the 100BASE-TX (100 Mbit/s Ethernet) standard as specified in IEEE 802.3.

[DoEth-002] The DoIP Edge Node shall support the 10BASE-T (10 Mbit/s Ethernet) standard as specified in IEEE 802.3.

NOTE The requirement to support 10 Mbit/s is intended as a fall-back solution in environments where a 100 Mbit/s connection cannot be established between the two Ethernet interfaces. In such cases, the connection can still be established at a reduced speed.

[DoEth-003] The DoIP Edge Node shall provide for isolation of 1 500 V for 1 min between the transformer coils, in accordance with IEC 60950-1 (TNV1 circuit) and IEEE 802.3, on the link to the outside network.

7.3 Ethernet data link layer requirements

This subclause specifies the requirements for implementation of the data link layer of Ethernet by the DoIP Edge Node so as to allow for backwards-compatible communication with older versions of Ethernet at the best achievable data rate.

[DoEth-004] The DoIP Edge Node shall support 10 Mbit/s Ethernet on the link to the external network.

[DoEth-005] The DoIP Edge Node shall support 100 Mbit/s Ethernet (100BASE-TX).

[DoEth-006] The DoIP Edge Node shall support Auto-Negotiation as specified in IEEE 802.3, which is an Ethernet procedure for automatic handshaking of two directly networked interfaces to connect with identical parameters (i.e. transmission rate and duplex mode).

[DoEth-007] The test equipment shall support the 100BASE-TX standard as specified in IEEE 802.3.

[DoEth-008] For improved fault tolerance against incorrect Ethernet cabling (1:1 connection/cross-linked), the test equipment shall support the Auto-MDI(X) feature.

NOTE The DoIP Edge Node is not required to support the Auto-MDI(X) feature.

7.4 Ethernet PHY and MAC requirements

[DoEth-009] The DoIP Edge Node shall use an Ethernet device that allows for detection of physical connects and disconnects (link detection) and notification of upper communication layers about these occurrences.

NOTE A DoIP Edge Node Ethernet Controller is not required to support Wake on LAN (WoL) as activation of the Ethernet hardware is ensured using the separate activation line described in [7.5](#).

7.5 Ethernet activation line requirements

7.5.1 Vehicle activation line requirements

Reasons for activating and deactivating the Ethernet Controller are

- reduction of electromagnetic interference, and
- reduction of power consumption of the DoIP Edge Node.

The Wake on LAN (WoL) feature cannot be used for this purpose as it requires knowledge of the MAC address of the controller in order to wake it up and this is typically not known when a vehicle drives into a repair workshop. Another disadvantage of the standard WoL feature is that the Magic Packet requires the Ethernet controller to process the complete frame, which results in increased current consumption.

[Figure 2](#) shows a schematic configuration of Ethernet and the activation line with the electrical parameters listed in [Table 2](#).

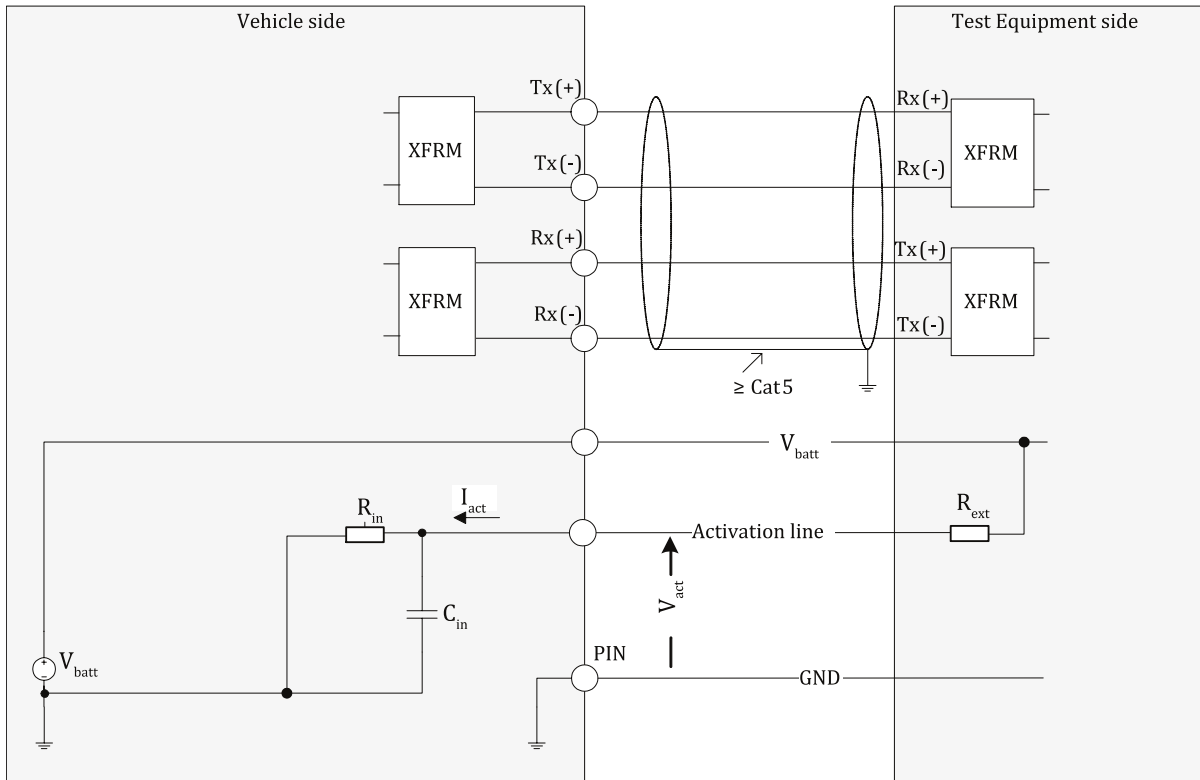

Key

- C_{in} internal capacitance
- I_{act} activation current
- R_{ext} external resistance
- R_{in} internal resistance
- V_{act} activation voltage
- V_{batt} battery voltage
- GND ground
- XFMR Ethernet transformer

Figure 2 — Equivalent circuit diagram

Table 2 gives an overview of the electrical parameters.

Table 2 — Overview of electrical parameters

Electrical parameter	12 V			24 V		
	Minimum	Typical	Maximum	Minimum	Typical	Maximum
R_{in}	2,9 k Ω (-1 %)	—	10 k Ω (+1 %)	2,9 k Ω (-1 %)	—	10 k Ω (+1 %)
C_{in}	10 nF (-5 %)	—	330 nF (+5 %)	10 nF (-5 %)	—	330 nF (+5 %)
I_{act}	0 mA ^a	—	8,5 mA	0 mA ^a	—	10 mA
R_{ext}	510 Ω (-5 %)	510 Ω	—	1 k Ω (-5 %)	1 k Ω	—
V_{act}	0 V	—	16 V	0 V	—	32 V
$V_{act} (t \leq 60 \text{ s})^a$	- 14 V	—	28 V	- 14 V	—	32 V

^a Limiting values.

[DoEth-011] The deactivation voltage threshold ($V_{inactive}$) shall be 2 V (see [Table 3](#)), implying that a voltage value below 2 V shall not activate the Ethernet controller of the DoIP Edge Node if Ethernet is already deactivated. This is to avoid random activation caused by ground shift or electromagnetic interference (see [Figure 3](#)).

[DoEth-012] The guaranteed activation voltage threshold (V_{active}) shall be 5 V.

[DoEth-013] The Ethernet hardware shall be activated within 200 ms of the signal V_{act} reaching between V_{active} and V_{max} . It is anticipated that the system designer could include a filter time constant in the receive circuit of less than 200 ms.

The Ethernet hardware shall remain active while V_{act} is between V_{active} and V_{max} .

[DoEth-014] The vehicle shall interpret V_{act} falling below $V_{inactive}$ for at least 200 ms as a signal from the Test Equipment indicating that the Ethernet hardware can be deactivated.

[DoEth-021] When the activation line is in the “guaranteed active” state, communication shall be allowed, although it will only be possible after a link has been detected.

[Figure 3](#) depicts the Ethernet activation and deactivation voltage thresholds and timings.

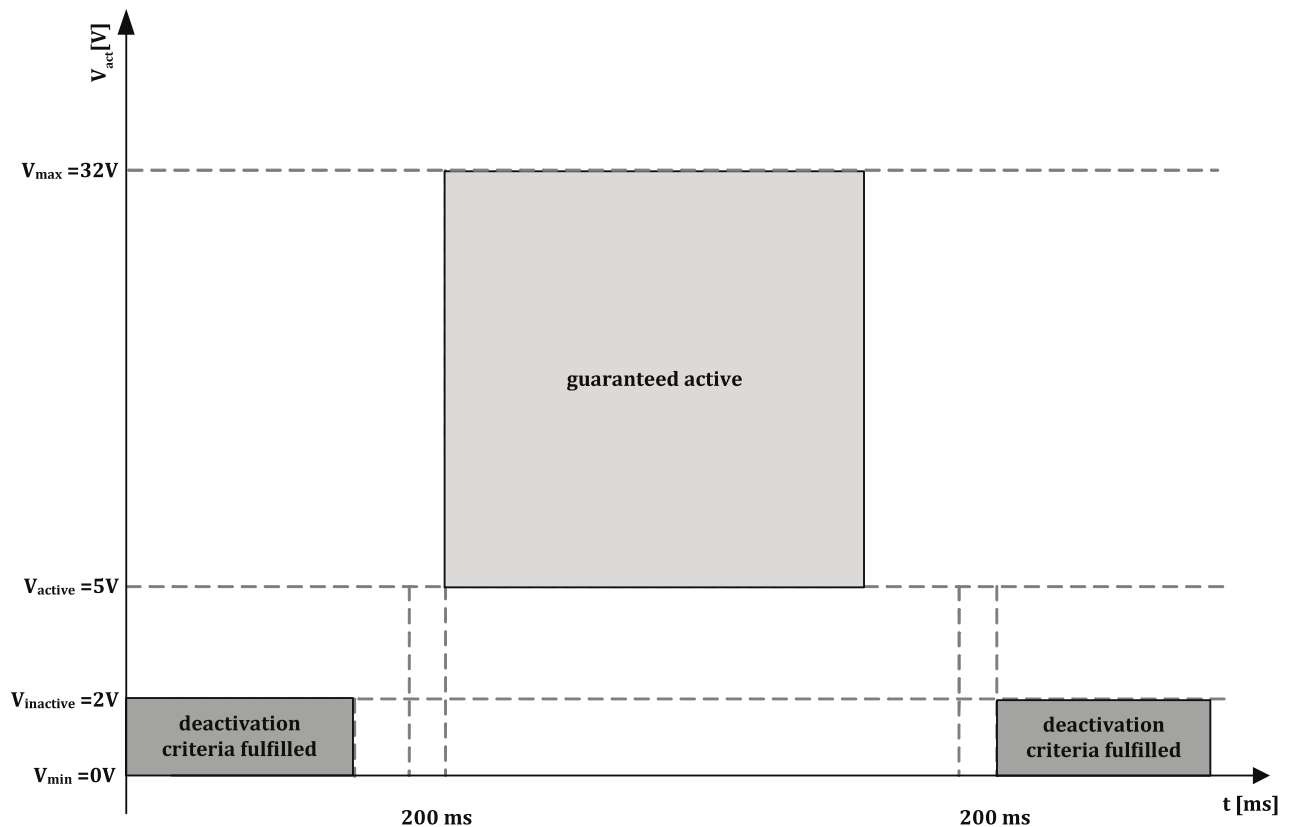

NOTE All areas in [Figure 3](#) which are not shown as “guaranteed active” or “deactivation criteria fulfilled” represent undefined behaviour.

Figure 3 — Ethernet activation and deactivation voltage thresholds and timings

[Table 3](#) defines the activation and deactivation voltage thresholds.

Table 3 — Activation and deactivation voltage thresholds

Parameter	Threshold
V_{active}	5 V
$V_{inactive}$	2 V
V_{min}	0 V
V_{max}	32 V

7.5.2 Vehicle activation line circuit example – Option 1 requirements

The pin 8 interface circuit on the vehicle side is required to fulfil two requirements. Firstly, the circuit should present resistive impedance and an input capacitance on pin 8 with respect to Signal Ground pin 5 according to [Table 4](#). This is used by the External Test Equipment to confirm the vehicle pin assignment in Option 1.

Secondly, the circuit is required to detect the voltage on pin 8 and according to [Figure 3](#) and [Table 3](#) and provide a corresponding signal to the vehicle internal systems to enable or disable DoIP Ethernet connectivity to the ISO 13400-4 diagnostic connector.

[Figure 4](#) shows the activation line circuit example – Option 1, which results in a switching voltage (activation, deactivation) threshold on the activation line of nominally 3,4 V.

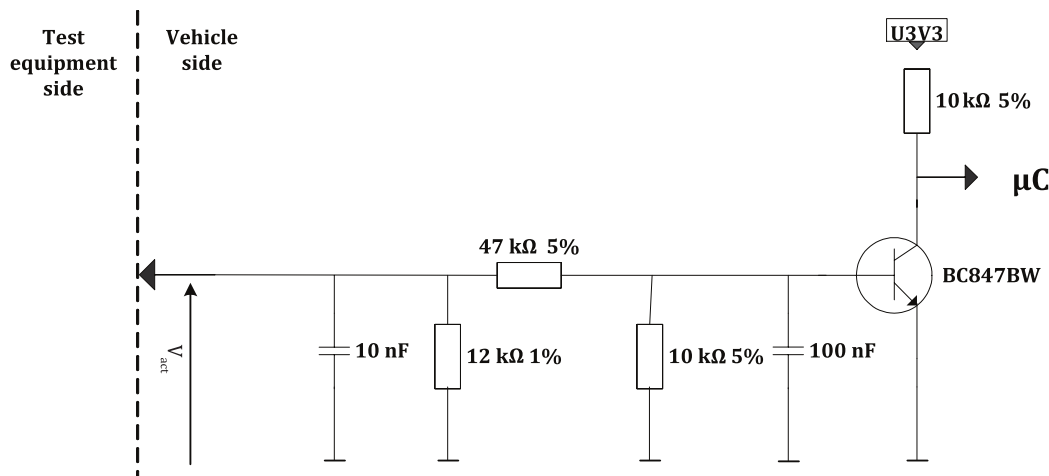

Figure 4 — Activation line circuit example – Option 1

[Table 4](#) defines the electrical parameters of the circuit example in [Figure 4](#).

Table 4 — Electrical parameters of activation line circuit example – Option 1 in [Figure 4](#)

Electrical parameter	Minimum	Typical	Maximum
R_{in}	9,3 KΩ	9,56 KΩ	9,8 KΩ
C_{in}	10 nF (-5 %)	10 nF	20 nF (+5 %)

The base-emitter resistance of a transistor needs to be taken into account when calculating R_{in} .

7.5.3 Vehicle activation line circuit example – Option 2 requirements

The pin 8 interface circuit on the vehicle side is required to fulfil two requirements. Firstly, the circuit should present resistive impedance and an input capacitance on pin 8 with respect to Signal Ground

pin 5 according to [Table 5](#). This is used by the External Test Equipment to confirm the vehicle pin assignment in Option 2.

Secondly, the circuit is required to detect the voltage on pin 8 relative to Signal Ground pin 5 and according to [Figure 3](#) and [Table 3](#) and provide a corresponding signal to the vehicle internal systems to enable or disable DoIP Ethernet connectivity to the ISO 13400-4 diagnostic connector.

[Figure 5](#) shows the activation line circuit example – Option 2, which results in a switching voltage (activation, deactivation) threshold on the activation line of nominally 4,4 V.

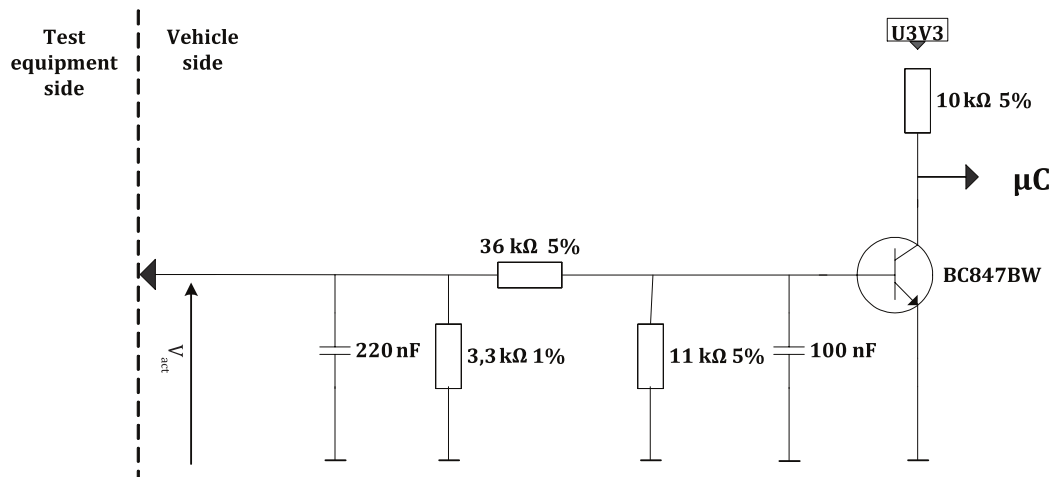

Figure 5 — Activation line circuit example – Option 2

[Table 5](#) defines the electrical parameters of the circuit example in [Figure 5](#).

Table 5 — Electrical parameters of activation line circuit example – Option 2 in [Figure 5](#)

Electrical parameter	Minimum	Typical	Maximum
R_{in}	2,9 kΩ (-1 %)	—	3,3 kΩ (+1 %)
C_{in}	200 nF (-5 %)	—	330 nF (+5 %)

The base-emitter resistance of a transistor needs to be taken into account when calculating R_{in} .

7.5.4 Principles of activation line operation

The activation line electrical parameters specified in this document have been extended and changed to be a bidirectional signal from external test equipment to the vehicle. These modifications support the identification of two different pin configurations on the vehicle side of the diagnostic connector called Options 1 and 2.

If a substantially different vehicle input resistance (see [Table 5](#)) is defined for vehicles with the Option 2 Ethernet pin assignment, then the external test equipment could use this same method to differentiate such a vehicle as having a different Ethernet pin assignment and respond with a change to the internal pin multiplexer settings accordingly.

7.5.5 External test equipment activation line requirements

[DoEth-017] In order to establish communication with the DoIP Edge Node over Ethernet, the test equipment needs to provide a voltage signal (V_{act}) on the Ethernet activation line in accordance with the requirements in [Table 3](#). Thus, only for the “guaranteed activation” range as depicted in [Figure 3](#) can communication with the vehicle be performed reliably. Outside this range, taking into account timing described by [DoEth-014], it depends on the vehicle manufacturer’s design whether communication can still be performed.

NOTE 1 Additional pre-conditions may be necessary in order to perform communication with the vehicle (e.g. ignition key in “Run” position). Depending on the vehicle manufacturer’s power network architecture, this implies that only providing the activation voltage signal does not necessarily “wake up” the vehicle.

[DoEth-018] When a connection is no longer required by the external test equipment it shall send a signal to the vehicle’s Ethernet hardware requesting deactivation according to [DoEth-014].

[DoEth-023] External test equipment which could be used with vehicles using both Options 1 and 2 Ethernet pin assignment shall be capable of

- measuring the voltage on the activation line using an A/D converter or analogue comparator;
- applying a switchable pull-up resistor of 4,7 KOhm ($\pm 5\%$) to the activation line;
- applying a switchable pull-up source voltage and current according to the limits in the parameter [Table 5](#);
- measuring the pull-up source voltage including any switch losses;
- calculating the voltage on pin 8 relative to the pull-up source voltage;
- determining the vehicle pin configuration according to the result of the calculation;
- switching Ethernet signals vehicle TX+, vehicle TX- from pins 3, 11 to pins 1, 9 accordingly;
- applying a voltage above 5 V (e.g. pull-up resistor) to the activation line. The external test equipment shall not exceed the specified input current (see [Table 2](#)).

NOTE 2 Physically disconnecting the external test equipment from the vehicle automatically results in the deactivation voltage thresholds specified in [7.5.1](#).

7.5.6 Vehicle manufacturers activation line requirements

[DoEth-022] Vehicle manufacturers using:

- Option 1 Ethernet pin assignment shall comply with the resistor and capacitor values as specified in [Table 4](#);
- Option 2 Ethernet pin assignment shall comply with the resistor and capacitor values as specified in [Table 5](#).

7.6 Spice simulation of activation line options

A Spice simulation result is shown here to illustrate the typical voltage/time profile using the example circuit with nominal component values. Component tolerance for the vehicle side components has been included to illustrate the effect of component tolerance.

Simulation setup:

- external test equipment pull-up applied with nominal resistance = 4,7 KOhm;
- traces show voltage on activation line for Options 1 and 2 including vehicle resistor tolerance spread;
- measurement sample point: $t_0 + 250 \mu\text{s}$;
- ground offset is assumed to be zero in this simulation;
- activation period has been intentionally shortened to illustrate rise/fall responses on the same trace.

[Figure 6](#) shows the activation line simulation – Option determination based on voltage.

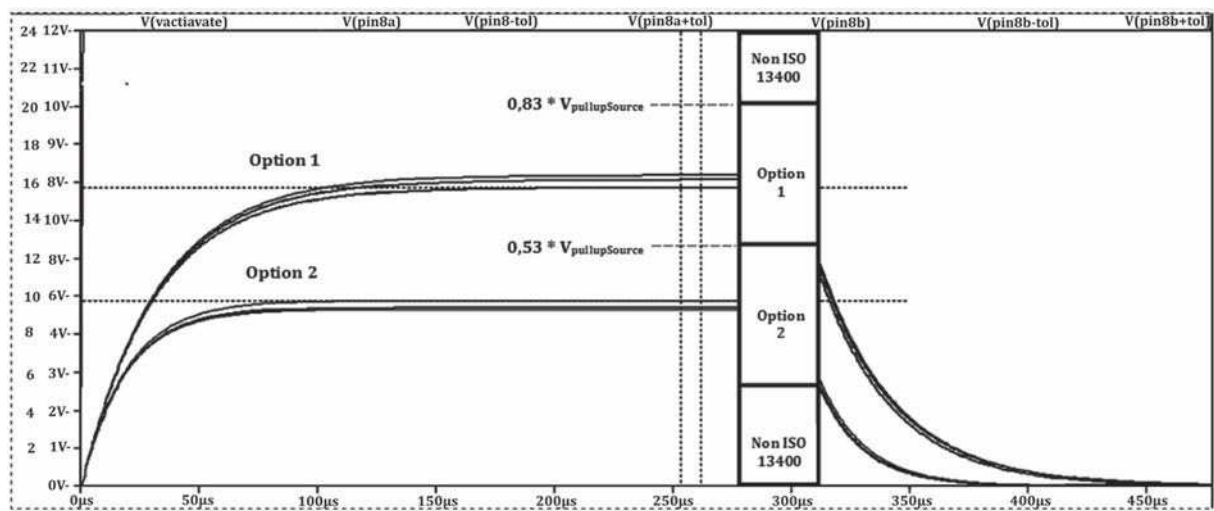
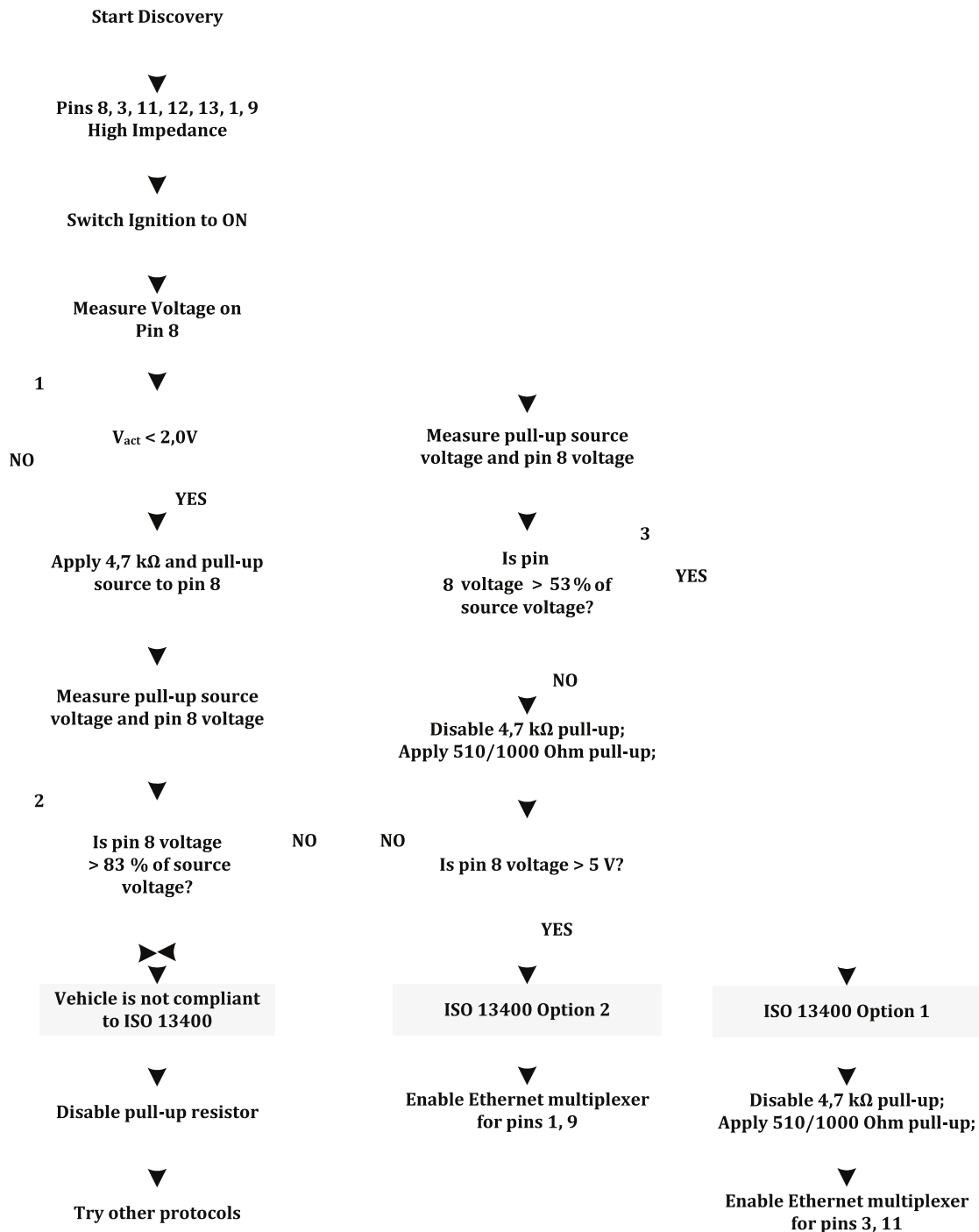

Figure 6 — Activation line simulation – Option determination based on voltage

7.7 Process to determine Options 1, 2 or non-ISO 13400

[Figure 7](#) shows the process for determining the option using the resistive determination method. The vehicle circuit presents different resistance to ground for each Ethernet option. The input resistance of the vehicle circuit on pin 8 is determined by applying a current through a known pull-up resistance, detecting the resultant voltage on pin 8 comparing it with the source voltage and determining the vehicle resistance by the ratio metric method.



Key

- 1 check if the vehicle is not pulling pin 8 high
- 2 check if the vehicle has a pin 8 pull-down resistor
- 3 determine the DoIP Option 1 or 2

Figure 7 — Process to determine Options 1, 2 or non-ISO 13400 using resistance method

7.8 Cable definitions

This subclause specifies the requirements regarding cable characteristics and cable length to ensure Ethernet communication at the intended speed of 100 Mbit/s.

- [DoEth-015]** The shield of the connecting cable shall be connected to the protective earth conductor (PE) on the test equipment side.
- [DoEth-016]** The shield of the connecting cable shall not be connected to the vehicle ground, either in the vehicle or in the test equipment.
- [DoEth-019]** The cable from the vehicle to the test equipment shall be at least Cat5.
- [DoEth-020]** While IEEE 802.3 (100BASE-TX) defines a Cat5 link segment length of 100 m, for successful transmission, the link segment length between the diagnostic connector of the vehicle and the next PHY (e.g. Ethernet port of test equipment or Ethernet switch) shall not exceed 50 m.

NOTE A detailed specification of cables that are needed for test equipment power supply or for the activation line circuit is outside the scope of this document; this will be left to the discretion of the vehicle manufacturer or test equipment manufacturer.

Bibliography

- [1] ISO 13400-1, *Road vehicles - Diagnostic communication over Internet Protocol (DoIP) — Part 1: General information and use case definition*
- [2] ISO 13400-2, *Road vehicles - Diagnostic communication over Internet Protocol (DoIP) — Part 2: Transport protocol and network layer services*
- [3] ISO 13400-4, *Road vehicles - Diagnostic communication over Internet Protocol (DoIP) — Part 4: Ethernet diagnostic connector*
- [4] ISO 14229-1, *Road vehicles — Unified diagnostic services (UDS) — Part 1: Specification and Requirements*
- [5] ISO 14229-2, *Road vehicles — Unified diagnostic services (UDS) — Part 2: Session layer services*
- [6] ISO 14229-5, *Road vehicles — Unified diagnostic services (UDS) — Part 5: Unified diagnostic services on Internet Protocol implementation (UDSonIP)*
- [7] ISO 27145-2, *Road vehicles — Implementation of World-Wide Harmonized On-Board Diagnostics (WWH-OBD) communication requirements — Part 2: Common data dictionary*
- [8] ISO 27145-3, *Road vehicles — Implementation of World-Wide Harmonized On-Board Diagnostics (WWH-OBD) communication requirements — Part 3: Common message dictionary*
- [9] ISO/IEC 7498-1, *Information technology — Open Systems Interconnection — Basic Reference Model: The Basic Model — Part 1*
- [10] ISO/IEC 10731, *Information technology — Open Systems Interconnection — Basic Reference Model — Conventions for the definition of OSI services*
- [11] SAE J1930-DA, *Electrical/Electronic Systems Diagnostic Terms, Definitions, Abbreviations, and Acronyms Web Tool Spreadsheet*
- [12] SAE J1939DA, *Digital Annex (SPNs)*
- [13] SAE J1939-73:2010, *Application Layer — Diagnostics*
- [14] SAE J1962, *Diagnostic Connector*
- [15] SAE J1979-DA, *Digital Annex of E/E Diagnostic Test Modes*
- [16] SAE J2012-DA, *Digital Annex of Diagnostic Trouble Code Definitions and Failure Type Byte Definitions*
- [17] TIA/EIA-568-B, *Commercial Building Telecommunications Cabling Standard*

