

INTERNATIONAL STANDARD

ISO 13350

First edition
1999-10-01

Industrial fans — Performance testing of jet fans

*Ventilateurs industriels — Essai de performance des ventilateurs
accélérateurs*



Reference number
ISO 13350:1999(E)

Contents

1 Scope	1
2 Normative references	1
3 Definitions	2
4 Symbols and abbreviations	4
5 Characteristics to be measured	5
6 Instrumentation and measurements	5
7 Determination of thrust	6
8 Determination of sound level	11
9 Determination of vibration velocity	13
10 Determination of flowrate	15
11 Presentation of results	18
12 Tolerances and conversion rules	19
Annex A (informative) Illustration of reference sound source	21
Annex B (informative) Correction of sound pressure levels	22
Annex C (informative) Conversion rules	23
Annex D (informative) Bibliography	25

© ISO 1999

All rights reserved. Unless otherwise specified, no part of this publication may be reproduced or utilized in any form or by any means, electronic or mechanical, including photocopying and microfilm, without permission in writing from the publisher.

International Organization for Standardization
Case postale 56 • CH-1211 Genève 20 • Switzerland
Internet iso@iso.ch

Printed in Switzerland

Foreword

ISO (the International Organization for Standardization) is a worldwide federation of national standards bodies (ISO member bodies). The work of preparing International Standards is normally carried out through ISO technical committees. Each member body interested in a subject for which a technical committee has been established has the right to be represented on that committee. International organizations, governmental and non-governmental, in liaison with ISO, also take part in the work. ISO collaborates closely with the International Electrotechnical Commission (IEC) on all matters of electrotechnical standardization.

Draft International Standards adopted by the technical committees are circulated to the member bodies for voting. Publication as an International Standard requires approval by at least 75 % of the member bodies casting a vote.

International Standard ISO 13350 was prepared by Technical Committee ISO/TC 117, *Industrial fans*.

Annexes A, B, C and D of this International Standard are for information only.

Introduction

The need for this new standard has been evident for some time. The use of the so-called jet fan to assist in controlling the quality of air in vehicle and train tunnels has become increasingly popular. The longitudinal method of ventilation can show advantages in initial cost and running cost compared to alternative systems, and smoke control in emergency conditions can be readily provided. At present, there is no published national or international standard for the performance testing of jet fans.

This International Standard, which forms part of the ISO/TC 117 series of fan standards, deals with the determination of those performance criteria essential to the correct application of jet fans. In describing the test and rating procedures, numerous references are made to ISO 5801 as well as to other relevant International Standards.

Industrial fans — Performance testing of jet fans

1 Scope

This International Standard deals with the determination of those technical characteristics needed to describe all aspects of the performance of jet fans as defined in ISO 13349. It does not cover those fans designed for ducted applications, nor those designed solely for air circulation, e.g. ceiling fans and table fans.

The test procedures described in this International Standard relate to laboratory conditions. The measurement of performance under on-site conditions is not included.

2 Normative references

The following standards contain provisions which, through reference in this text, constitute provisions of this International Standard. At the time of publication, the editions indicated were valid. All standards are subject to revision, and parties to agreements based on this International Standard are encouraged to investigate the possibility of applying the most recent editions of the standards indicated below. Member of IEC and ISO maintain registers for currently valid International Standards.

ISO 1940-1:1986, *Mechanical vibration — Balance quality requirements of rigid rotors — Part 1: Determination of permissible residual unbalance.*

ISO 5801:1997, *Industrial fans — Performance testing using standardized airways.*

ISO 13347:—¹⁾, *Industrial fans — Determination of fan sound power level under standardized laboratory conditions.*

ISO 13349:—¹⁾, *Industrial fans — Vocabulary and definitions of categories.*

ISO 14695:—¹⁾, *Industrial fans — Vibration measurement method.*

IEC 60034-2:1972, *Rotating electrical machines — Part 2: Methods for determining losses and efficiency of rotating electrical machinery from tests (excluding machines for traction vehicles).*

IEC 60034-14:1996, *Rotating electrical machines — Part 14: Mechanical vibration of certain machines with shaft heights 56 mm and higher — Measurement, evaluation and limits of the vibration severity.*

¹⁾ To be published.

3 Definitions

For the purposes of this International Standard, the definitions given in ISO 13349, ISO 5801 and the following apply.

3.1 effective fan dynamic pressure

ρ_d
conventional quantity representative of the dynamic component of the fan output, calculated, in the particular case of a jet fan, from the effective fan outlet velocity and the inlet density

NOTE The effective fan dynamic pressure will not be the same as the average of the dynamic pressures across the section because it excludes from consideration that part of the dynamic energy flux which is due only to departures from uniform axial velocity distribution.

3.2 effective fan outlet area

A_{eff}
in the particular case of a jet fan, outlet area with deductions for motors, fairings or other obstructions

NOTE 1 If the silencer centrebody reaches the outlet plane of the fan, then the effective fan outlet area is defined as the annulus area at the fan outlet plane as shown in figure 1a).

NOTE 2 If the fan has a silencer without centrebody [see figure 1 b)], the effective fan outlet area will be close to the cross-sectional area inside the silencer in order to clear any exit bellmouth form.

NOTE 3 If the centrebody (motor or silencer core) does not extend to the outlet plane, the effective fan outlet area will approach the annulus area between the casing and the motor, but with some increase, as defined in figure 1c), for the distance between the centrebody and the outlet. Where the motor is on the upstream side, figure 1c) is applied to the impeller hub rather than the motor, as illustrated.

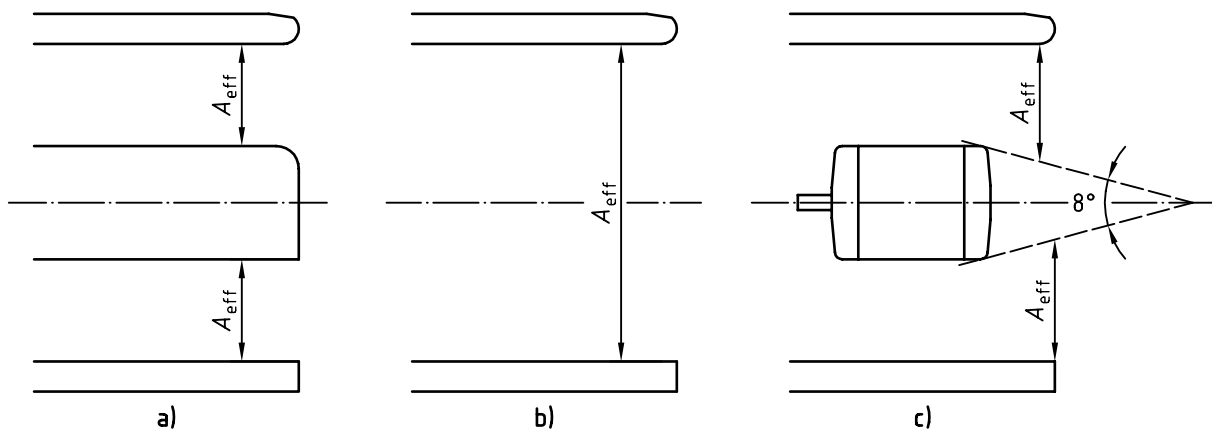

Figure 1 — Effective fan outlet area

3.3 effective fan outlet velocity

V_{eff}
calculated from the thrust, the inlet density and the effective fan outlet area as detailed in 11.2

3.4 fan outlet velocity

in the particular case of a jet fan, inlet volume flow divided by effective fan outlet area, A_{eff}

3.5 fan air power

conventional power output; in the particular case of a jet fan, product of inlet volume flow and effective fan dynamic pressure

3.6 impeller tip speed

u

peripheral speed of the impeller blade tips

3.7 thrust

T_m, T_c

fan thrust measured or calculated in accordance with this International Standard

3.8 thrust/power ratio

r_t

thrust divided by impeller power

NOTE An alternative definition of thrust/power ratio which has sometimes been used: thrust divided by motor input power. This definition is deprecated, as it will vary according to the motor manufacturer used. It also results in a lower value, as the motor losses are included.

3.9 fan guard

guard designed to prevent the ingestion of relatively large foreign bodies, such as drink cans, and sometimes fitted to the inlet and outlet of jet fans

NOTE Guards can have a marked effect on the thrust performance and noise level. Where they are specified, measurements should be made with these guards in place.

3.10 chamber

airway in which the air velocity is small compared with that at the fan inlet or outlet

3.11 test enclosure

room, or other space protected from draught, in which the fan and test airways are situated

3.12 impeller balance grade

grade G as specified in ISO 1940-1

3.13 fan vibration velocity

unfiltered r.m.s. vibration velocity over the frequency range 10 Hz to 10 kHz measured in accordance with this International Standard and with ISO 14695

3.14 fan impeller efficiency

η_R

fan air power divided by impeller power

3.15 overall efficiency

η_E

fan air power divided by motor input power

3.16 sound pressure level

L_p

ten times the logarithm to the base 10 of the ratio of the square of the sound pressure radiated by the sound source under test to the square of the reference sound pressure

3.17 sound power level

L_w
ten times the logarithm to the base 10 of the ratio of the sound power radiated by the sound source under test to the reference sound power

3.18 inlet sound power level

L_{w1}
sound power level of the fan determined at the fan inlet

3.19 outlet sound power level

L_{w2}
sound power level of the fan determined at the fan outlet

3.20 frequency range of interest

for general purposes, the frequency range including the octave bands with centre frequencies between 63 Hz and 8 000 Hz and the one-third octave bands with centre frequencies between 50 Hz and 10 000 Hz

4 Symbols and abbreviations

The following symbols and units shall apply for the parameters listed.

Parameter	Symbol	Unit
Effective fan outlet area	A_{eff}	m ²
Nominal fan diameter	D_R	m
Length of upstream chamber side	D_3	m
Sound pressure level	L_p	dB (ref. 20 µPa)
Sound power level	L_w	dB (ref. 1 pW)
Inlet sound power level	L_{w1}	dB (ref. 1 pW)
Outlet sound power level	L_{w2}	dB (ref. 1 pW)
rotational speed	N	r/s
Differential pressure across a flow measuring device	p	P _a
Effective fan dynamic pressure	p_d	P _a
Volume flow	q_V	m ³ /s
Impeller balance grade (ISO 1940-1)	G	µm
Thrust/power ratio	r_t	N/kW
Calculated thrust	T_c	N
Measured thrust	T_m	N
Impeller tip speed (see 3.6)	u	m/s
Effective fan outlet velocity	v_{eff}	m/s
Mean throughflow velocity in a tunnel at a specified section	v_t	m/s
Inlet density taken as equal to the density in the test enclosure	ρ_a	kg/m ³
Overall efficiency	η_E	—
Motor efficiency	η_M	—
Fan impeller efficiency	η_R	—

5 Characteristics to be measured

5.1 General

In order that a jet type fan be correctly applied and give satisfactory performance and reliability in service, it is necessary to determine a number of technical performance characteristics in addition to knowing the more obvious mechanical features such as mass, overall dimensions and installation dimensions.

5.2 Thrust

Friction on the tunnel walls, inlet and outlet losses and sometimes traffic drag, combined with climatic effects at tunnel portals, create a pressure drop through the tunnel. The pressure drop is matched by the sum of the pressure increases by the jet fans due to the momentum transfer between fan discharge airflow and airflow in the tunnel. As it is impossible to measure the momentum of the fan discharge airflow, and the rate of change in momentum is equal and opposite to the thrust, thrust is measured instead.

5.3 Input power

In order to calculate the cost of operating the jet fans in a tunnel, and there may be a substantial number, it is necessary to know the input power to the fan motor.

5.4 Sound levels

Sound levels, usually at inlet and outlet, are established in order to ensure that the jet fan and silencer combination is optimized to match the tunnel sound level requirements.

NOTE The fan manufacturer can only guarantee the sound power level of the fan. The sound pressure in the tunnel will depend on the size and sound absorption characteristics of the tunnel, which are outside the fan manufacturer's responsibility.

5.5 Vibration velocity

For reasons of safety, reliability and maintainability, it is essential that a realistic vibration velocity is specified and recorded on tunnel fans. These shall be measured at the support points in accordance with ISO 14695.

5.6 Volume flowrate

Volume flowrate need only be measured if required for contractual reasons. It is the effective fan outlet velocity which is used to evaluate the optimum number, size and spacing of jet fans in a tunnel, and is calculated in accordance with 11.2.

6 Instrumentation and measurements

6.1 Dimensions and areas

The measurement of dimensions and the determination of areas shall be in accordance with clause 10 of ISO 5801:1997.

6.2 Rotational speed

The rotational speed of the impeller shall be determined in accordance with clause 8 of ISO 5801:1997.

6.3 Thrust

6.3.1 Force balance systems

By the use of calibrated weights, force balance systems shall permit the determination of force or thrust with an uncertainty of $\pm 5\%$.

6.3.2 Force transducers

After calibration by the use of calibrated weights, force transducers shall permit the determination of thrust with an uncertainty of $\pm 5\%$.

6.4 Input power

Determination of the power input to the electric motor or to the impeller shall be carried out in accordance with clause 9 of ISO 5801:1997.

6.5 Sound level

The sound-level measuring system, including microphones, windshields, cables, amplifiers and frequency analyser, shall be in accordance with the requirements given in ISO 13347.

6.6 Vibration velocity

Instruments to measure r.m.s. vibration velocity shall be used to record fan vibration velocities. These shall be in accordance with ISO 14695.

6.7 Volume flowrate

6.7.1 Instruments for the measurement of pressure.

Manometers for the measurement of differential pressure, and barometers for the measurement of atmospheric pressure in the test enclosure, shall comply with the requirements of clause 5 of ISO 5801:1997.

6.7.2 Instruments for the measurement of temperature.

Thermometers shall comply with the requirements of clause 7 of ISO 5801:1997.

7 Determination of thrust

7.1 General

There are two basic configurations acceptable for the determination of fan thrust: suspended configuration and supported configuration. In addition to the need to measure force accurately, the first method requires that the suspension elements be kept precisely vertical and parallel with a vertical plane(s) passing through the fan axis, whilst the second method requires accurate construction and levelling of the support assembly. In either case, thrust shall be determined by the use of calibrated weights, spring balance or force transducer.

7.2 Suspended configuration

Figures 2 and 3 show typical arrangements of suspended configurations. The fan is suspended from a framework or gantry with the suspension elements at least one fan-diameter long. The frame should allow free airflow, particularly at the fan inlet. Below or surrounding the fan is a rigid framework which serves a threefold function:

- a) provide the reference point for the fan test assembly under static conditions,
- b) provide support for a pulley system to take calibrated weights or a spring balance, and
- c) provide a reaction point for a force transducer.

Under operating conditions, the measuring system loads are adjusted to return the fan to the static positions, to within ± 2 mm, and thus ensure that the suspension elements are precisely vertical. The thrust can then be measured directly.

NOTE It should be noted that with the thrust/weight ratios typical of a jet fan, it is doubtful whether the desired accuracy of thrust measurement can be attained by other means, such as measuring the angle of the suspension elements from the vertical or the change in height between the fan switched off and operational, and then calculating the thrust.

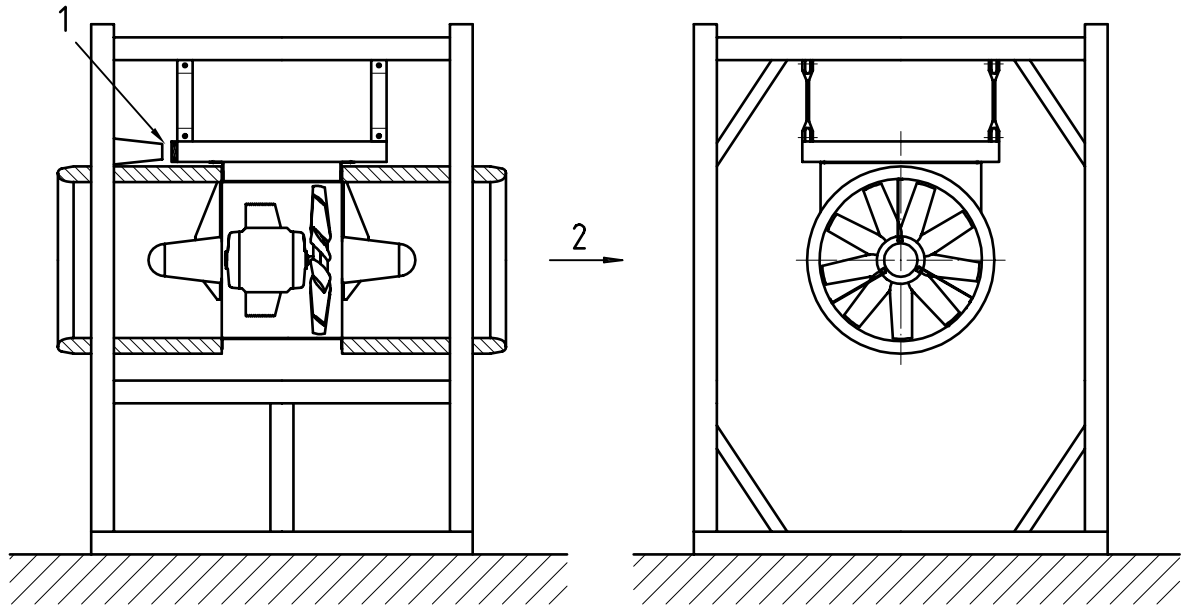

Key

- 1 Adjustable position of transducer/measuring system
- 2 Air flow

NOTE The fan should be accurately levelled prior to testing.

Figure 2 — Thrust measuring layout (suspended method 1)

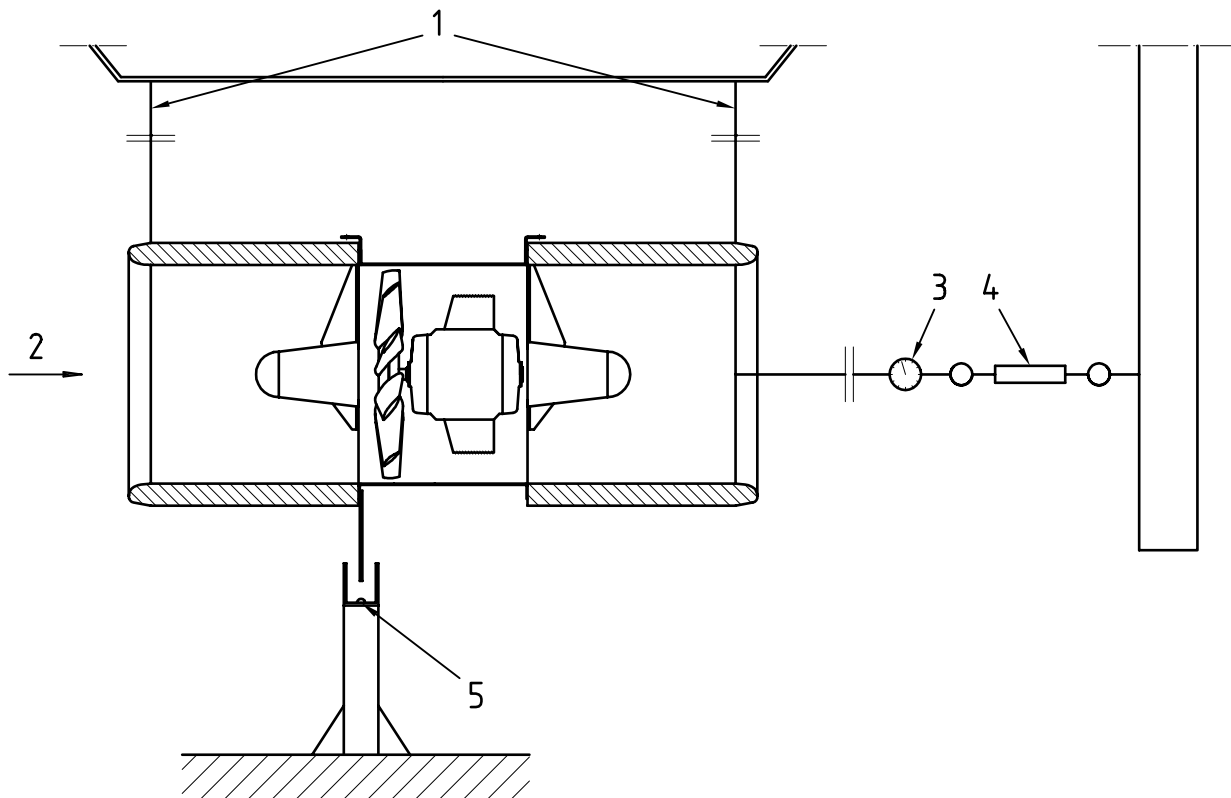

Key

- 1 Suspension cables
- 2 Air flow
- 3 Spring balance
- 4 Adjustable restraint
- 5 Reference point

NOTE The fan should be accurately levelled prior to testing.

Figure 3 — Thrust measuring layout (suspended method 2)

7.3 Supported configuration

Arrangements of the supported configuration are shown in figures 4, 5 and 6. The fan is supported, via low-friction linear bearings or leaf springs, on a rigid framework. The fan, to an extent limited by stops, is free to move in either direction. Before commencing any tests, the assembly shall be carefully levelled, in each direction, such that the same effort is required to move the assembly along the axis of the fan in either direction.

Under operating conditions, the measuring system loads are adjusted to ensure the movement is not being restrained by the stops. Thrust can then be measured directly. In the case of the use of a force transducer, the fan can be allowed to abut the sensor directly.

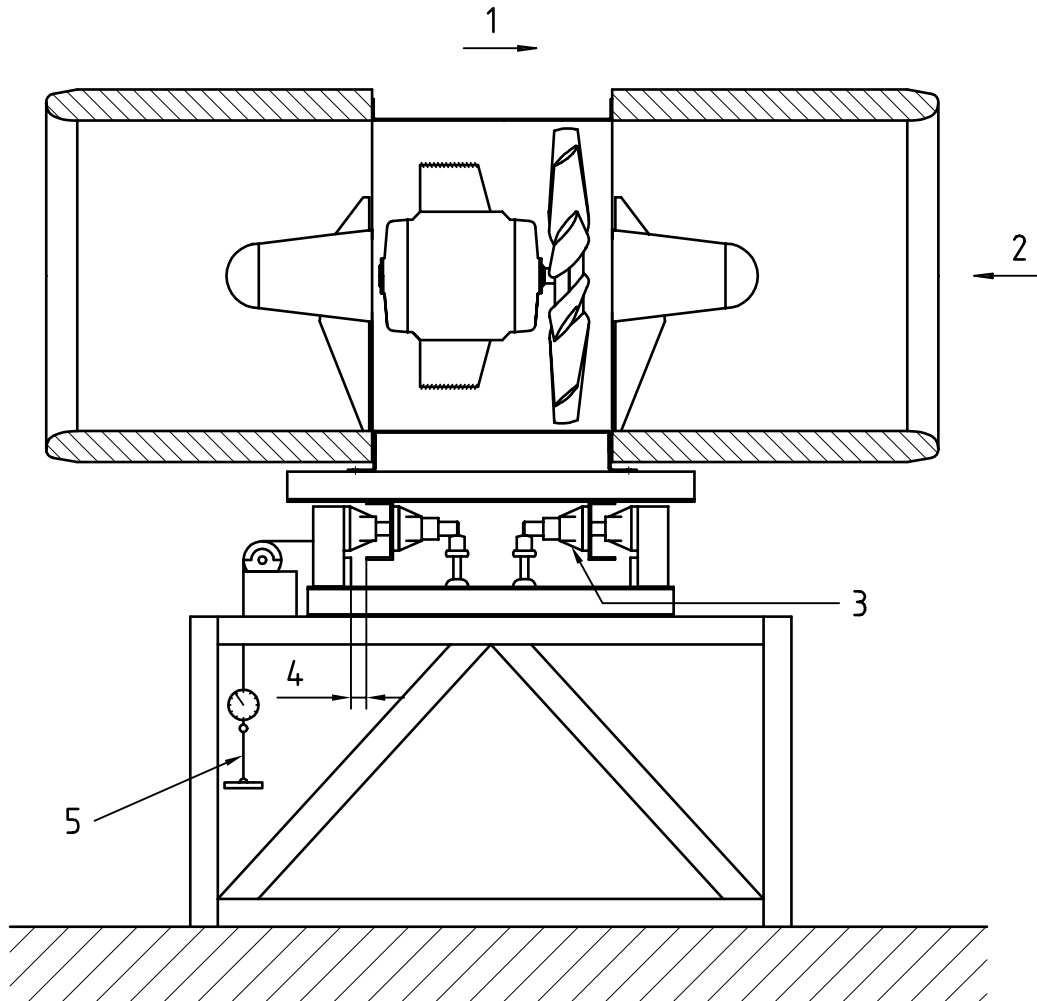

- Key**
- 1 Direction of fan movement
 - 2 Air flow
 - 3 Linear bearings
 - 4 Fan movement possible
 - 5 Thrust gauge (measurement in kg direct off gauge + mass of gauge in suspension = thrust)

NOTE The fan should be accurately levelled prior to testing.

Figure 4 — Thrust measuring layout (supported method 1)

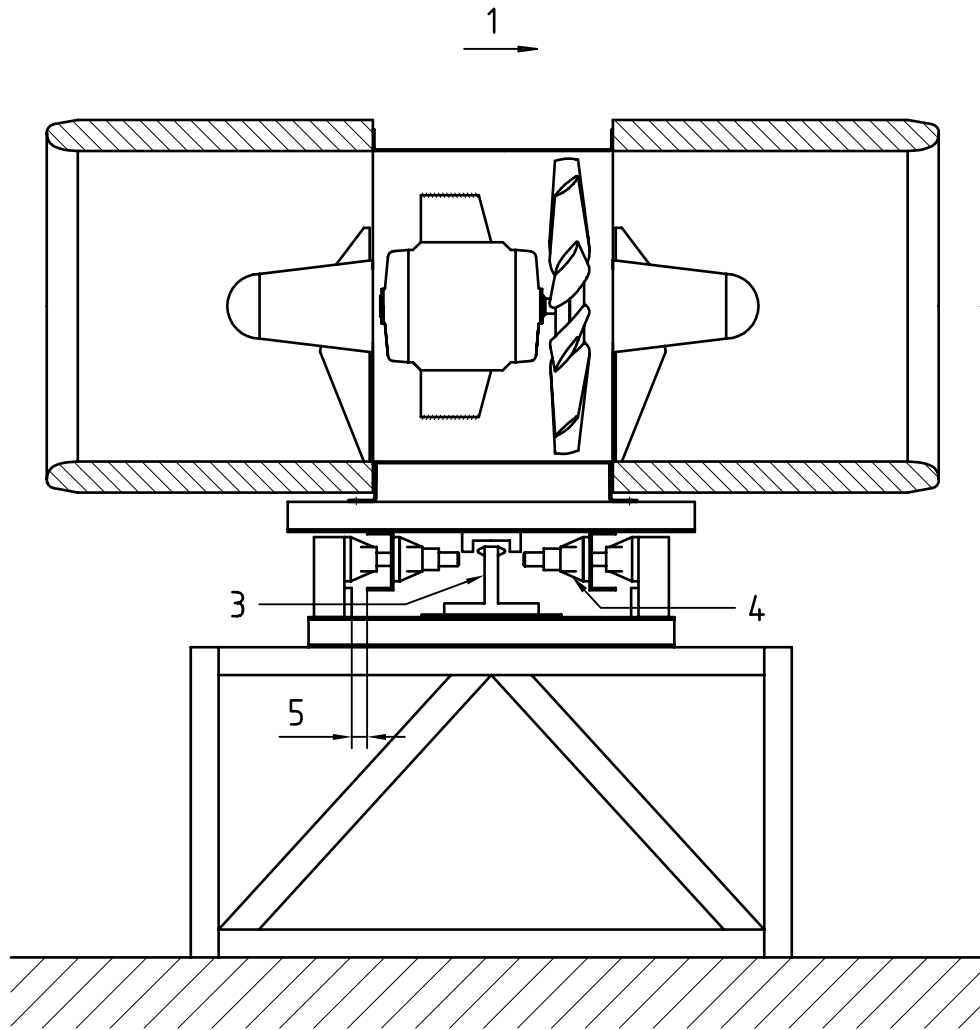

Key

- | | | | |
|---|-----------------------------|---|-----------------------|
| 1 | Direction of fan movement | 4 | Linear bearings |
| 2 | Air flow | 5 | Fan movement possible |
| 3 | Transducer/measuring system | | |

NOTE The fan should be accurately levelled prior to testing.

Figure 5 — Thrust measuring layout (supported method 2)

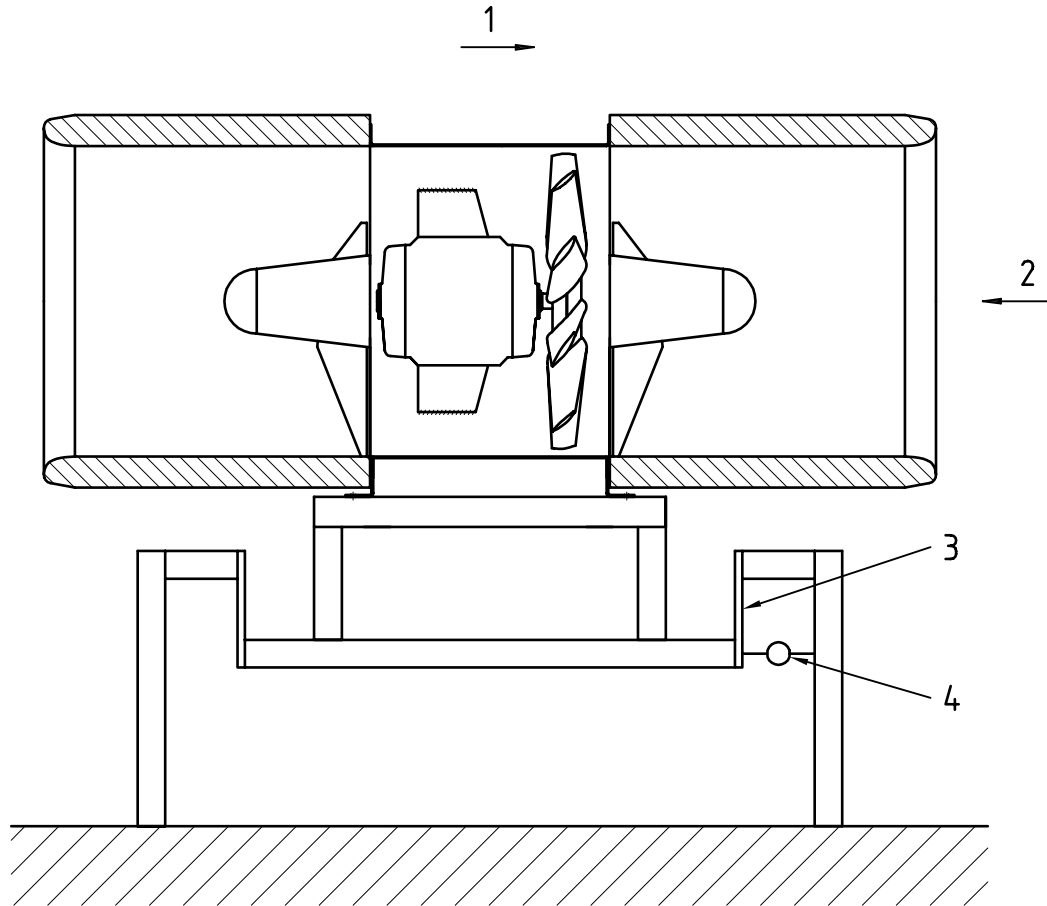

Key

- | | | | |
|---|---------------------------|---|-------------|
| 1 | Direction of fan movement | 3 | Leaf spring |
| 2 | Air flow | 4 | Load cell |

NOTE The fan should be accurately levelled prior to testing.

Figure 6 — Thrust measuring layout (supported method 3)

7.4 Test procedures

To ensure that thrust is measured to the required accuracy, steps shall be taken to minimize errors due to setting-up/rigging of the test arrangement. Though calibrated weights or spring balances are specified, if a spring balance is employed to register thrust and it is supported via a pulley, its mass must be accurately known and added to the measured thrust.

If a force transducer is being used to measure thrust, it is recommended that it is calibrated, for example by using a pulley and weight system, at no more than 12-monthly intervals. Where the deviation is more than 1 % of the reading, then recalibration shall be reduced to 3-monthly intervals.

Where the supported method is being used, precautions shall be taken to ensure that the force required to move the fan in either direction is the same and that the assembly is therefore level.

Thrust readings shall be recorded when both the thrust and power input readings have stabilized, or at least 10 min after start-up.

7.5 Test enclosure

Figure 7 shows the clearances required in the test enclosure.

Dimensions in meters

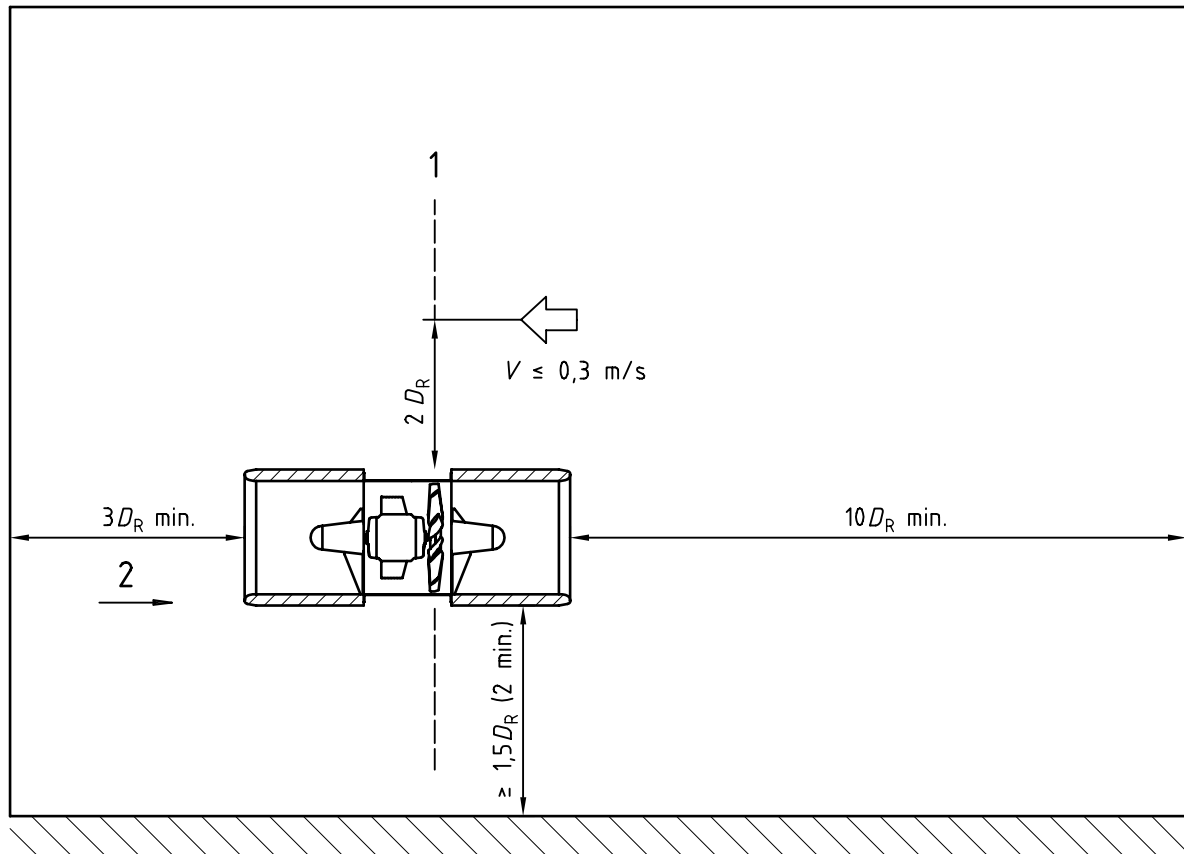

Key

- 1 Plane through impeller
- 2 Air flow

Figure 7 — Thrust measuring enclosure

8 Determination of sound level

8.1 General

Sound levels are measured by the semireverberant method. The method is essentially practical and, apart from the sound-measuring instrumentation, minimal facilities are required: a suitable enclosure and a calibrated sound source.

As the fan has only one operating point, at zero resistance, there are no complications which could arise from the noise generated by the "loading means". Similarly, since only open inlet or open outlet sound levels are required, anechoic terminators are unnecessary. It should be recognized that the method measures the noise radiated by the fan, whether from the fan inlet or outlet or from the fan casing, thus representing the same situation as when the fan is installed in a tunnel.

8.2 Test arrangement

Positioning of the fan, calibrated reference sound source and the microphone paths are shown in figure 8.

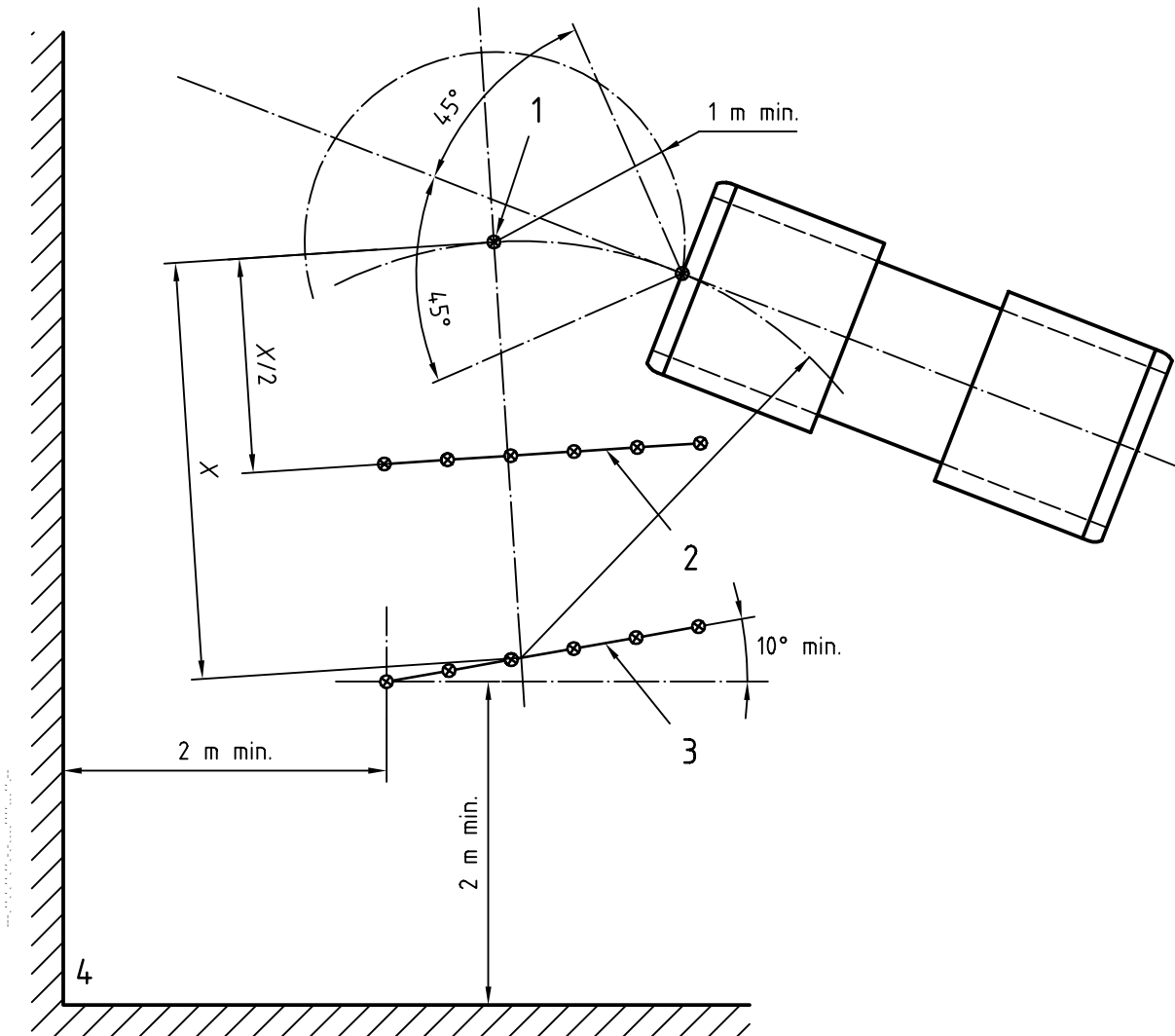

Key

- 1 Reference source
- 2 Secondary microphone path
- 3 Primary microphone path
- 4 All surfaces hard finish

NOTE

- 1 Microphone traverse plane should be greater than 10° from parallel to any surface.
- 2 Maximum air velocity over microphone 1 m/s.
- 3 Microphone, RSS, fan sound sources cannot be within 0,3 m of room centrelines.
- 4 Equipment or vane placement is not restricted by this International Standard provided above conditions are met.
- 5 Room shape is not specified in this International Standard, but rooms having certain proportions will perform more successfully (6).
- 6 Room volume is not specified, but the room should be large enough in volume such that the volume of the test fan and associated duct work does not exceed 1 % of that room volume.

Figure 8 — Semi-reverberant enclosure

8.3 Enclosure suitability

The semireverberant chamber shall meet the requirements of ISO 13347.

A primary microphone path shall be located on an arc or straight line of length between 1,5 m and 3 m at a distance of not less than 2 m from any major reflecting surface. No point on this path shall be within 45° of the centreline of the fan sound source, and the path itself shall form an angle greater than 10° with any chamber surface and shall be located towards a corner of the chamber. The path shall be so located that the microphone is not subjected to an air velocity in excess of 2 m/s (see figure 8).

A reference sound source shall be located such that its acoustic centre is the same distance from the midpoint of the microphone path as the centre of the fan sound, but not nearer than 1 m to the latter, or to any major reflecting surface. The reference sound source shall meet the requirements of ISO 13347. The reference sound source shall be run at a speed within 2 % of the speed at which it was calibrated.

With the reference sound source operating, but with the test fan impeller stationary, readings of sound pressure level shall be made in each octave band along the primary microphone path, and the average value along the path estimated. A secondary microphone path, similar to the primary microphone path and of the same length, shall be established at a position halfway between the reference sound source and the midpoint of the original microphone path, and at right angles to the line joining them. The average sound pressure level along this path in each octave band shall not be more than 3 dB above the average for the primary microphone path, both values being corrected for background noise as recommended in annex B.

8.4 Measurement procedure

Before conducting actual measurements, and with both the test fan and the reference sound source inoperative, the average sound pressure level, in each octave band shall be determined along the primary microphone path. This shall be at least 6 dB in each octave band lower than the average sound pressure level measured from either the fan sound source or the reference sound source. Corrections for background noise should be made as recommended in annex B.

With the reference sound source in operation, but with the test fan impeller stationary, readings of sound pressure shall be made, in each octave band, along the primary microphone path, and the average sound pressure level $L_{p(r)}$ determined. With the reference sound source removed and the test fan running, readings of sound pressure level shall be made and the average sound pressure level $L_{p(m)}$, in each octave band, determined. The values of $L_{p(r)}$ and $L_{p(m)}$ are corrected, where necessary, as recommended in annex B, and the open inlet or open outlet sound power level of the fan L_w calculated, in each octave band, from :

$$L_w = L_{p(m)} - L_{p(r)} + L_{w(r)}$$

where

$L_{w(r)}$ is the sound power level of the reference sound source.

The fan shall be turned through 180° and the measurement repeated. The highest levels in each case shall be reported.

The conformal surface method specified in ISO 3744 may be alternatively used, provided that this is clearly stated, noting that the measuring points may be in the acoustic near field and additional readings may accordingly be necessary.

9 Determination of vibration velocity

9.1 General

Because the jet fan, for practical purposes, has only one operating point as far as standard laboratory tests are concerned, the arrangements for testing vibration velocity can be simplified when compared with those specified in ISO 14695.

9.2 Test arrangement

Figure 9 illustrates the arrangement which shall be used for measuring vibration velocity. Tests shall be taken with the same jet fan configuration as will be supplied to the customer. In other works, upstream and/or downstream silencers should be fitted as appropriate. Where vibration isolators are specified and vibration levels are required to be measured, the minimum static deflections given in table 1 shall be used for the purpose of the measurement.

Unless agreed otherwise between client and supplier, the impeller of the fan unit shall be balanced to grade G6.3 of ISO 1940-1 and the electric motor shall be supplied to the normal vibration level for the motor frame size in accordance with IEC 60034-14.

Table 1

Rotational speed r/min	Minimum static deflection mm
850 to 1000	15
1100 to 1800	8
2800 and above	2,5

NOTE For practical reasons, the minimum static deflections in table 1 are very much reduced in actual operating conditions.

Example of sensor position

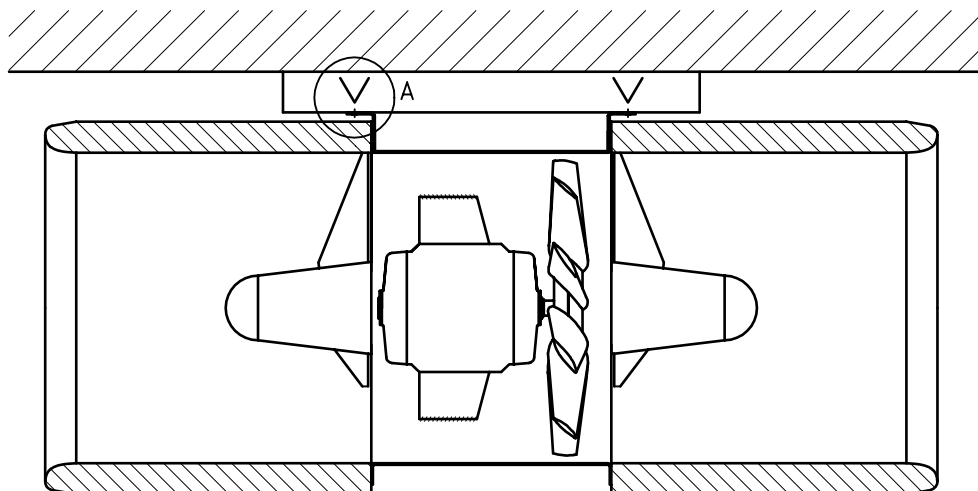
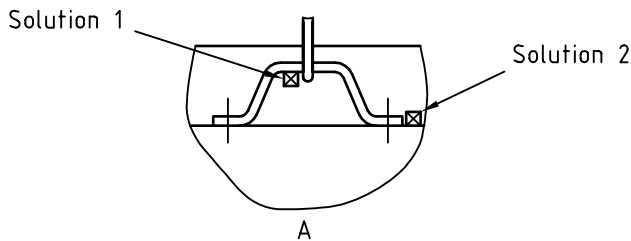

NOTE Vibration levels are taken at the attachments to the suspending/supporting structure indicated "V".

Figure 9 — Vibration measuring positions for jet fans

9.3 Test procedure

Unless agreed otherwise between client and supplier, vibration velocities shall be measured in accordance with annex B of ISO 14695: —. Owing to the axial symmetry of the jet fan and the simple two-bearing assembly, it is only necessary to record the vibration in the vertical direction.

Two readings of vibration shall be recorded, one on the upstream side and one on the downstream side mounting bracket. The measured levels shall be: vertical vibration velocity in mm/s r.m.s. filtered to impeller velocity in r/min.

9.4 Acceptance vibration velocity

The maximum acceptance vibration velocities are given in table 2.

Table 2

Mounting method	Maximum acceptance vibration velocity mm/s r.m.s.
Vibration isolators as in table 1	4,5
Hard-mounted	2,8

10 Determination of flowrate

10.1 General

It should be noted that the flow through a jet fan has no direct relationship with the flow through a tunnel, and that this is not a primary requirement in the specification of a jet fan.

There are three methods available for the determination of flowrate:

- the first method makes use of an upstream chamber test configuration. In this case a booster fan forms part of the test set-up, enabling the fan operating point to be simulated correctly;
- the second method uses a Pitot traverse at the jet fan inlet;
- the third method, which is the most convenient but probably the least accurate, uses a Venturi nozzle or conical inlet, connected upstream of the jet fan, as the flow-measuring device.

10.2 Upstream chamber method

Installation of the fan in the chamber is illustrated in figure 10. The arrangement simulates a type A installation. Upstream sections of the test assembly shall be in accordance with 31.2 of ISO 5801:1997.

A Venturi nozzle or conical inlet can be used to determine flowrate in accordance with clause 22 or 24 respectively of ISO 5801:1997.

In order to establish the correct fan operating point, with no adverse pressure across the fan, a test system booster fan shall be controlled such that

$$p_{e3} = p_{e2} = 0$$

where

p_{e3} is the gauge pressure in the fan chamber;

p_{e2} is the gauge pressure at the fan outlet.

If it is not possible to control the booster accurately, it may be necessary to measure the flow at more than one operating point.

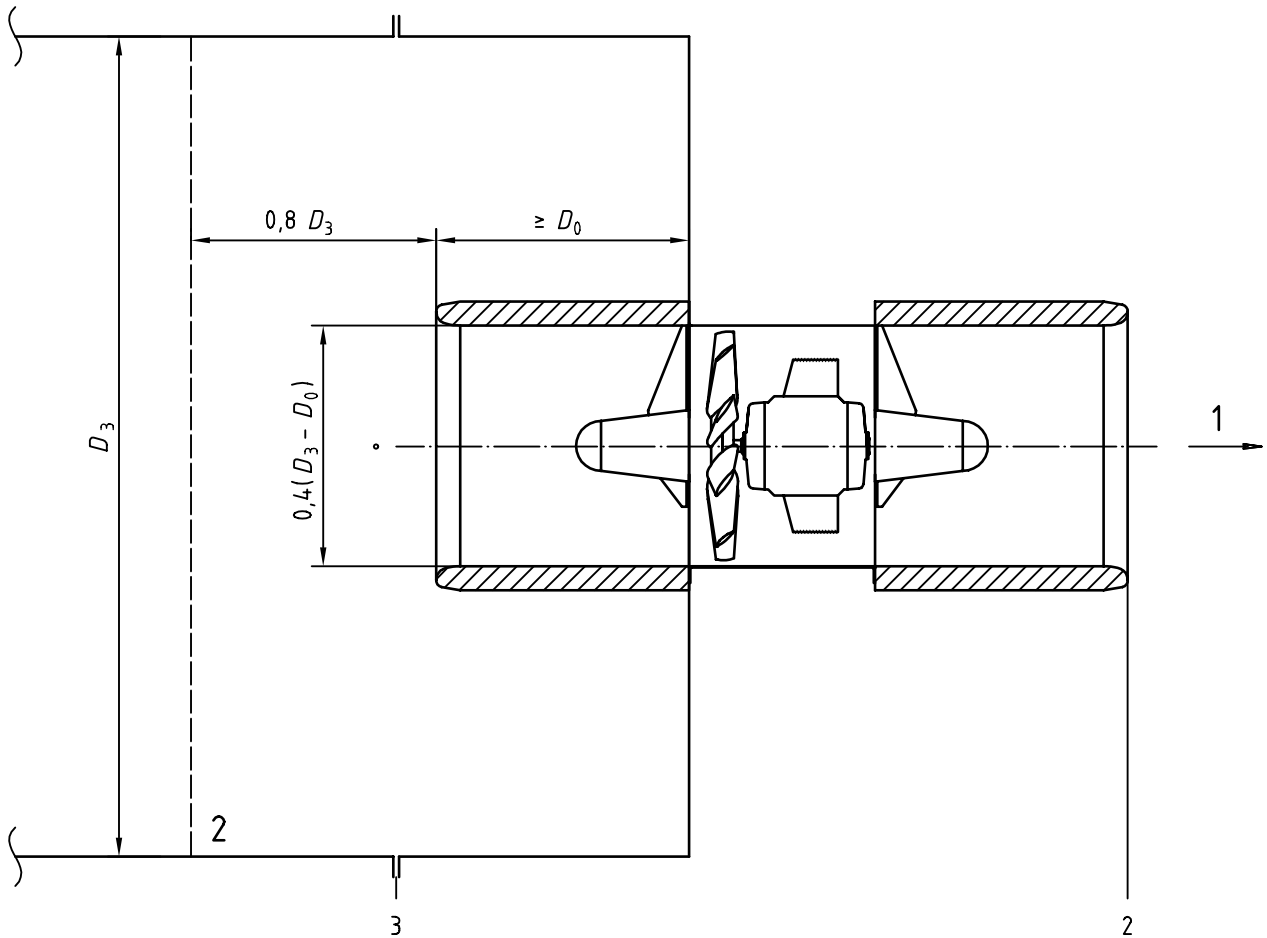

Key

- 1 Air flow
- 2 Screen

Figure 10 — Flow-measuring installation (upstream chamber)

10.3 Upstream Pitot traverse method

For this method, the flowrate should be determined in accordance with clause 26 of ISO 5801:1997 (preferably upstream of the impeller) (see figure 11).

10.4 Directly connected flowrate-measuring device

The flowrate-measuring device shall be connected, by suitable means, to the fan inlet as illustrated in figure 12. Details of the Venturi nozzle shall be in accordance with figure 11 of ISO 5801:1997, whilst the conical inlet shall comply with figure 16 of ISO 5801:1997. For the purpose of flowrate determination in accordance with this International Standard, an antiswirl device is not required.

Flowrate for the Venturi nozzle is calculated in accordance with clause 22 and that for the conical inlet in accordance with clause 24 of ISO 5801:1997.

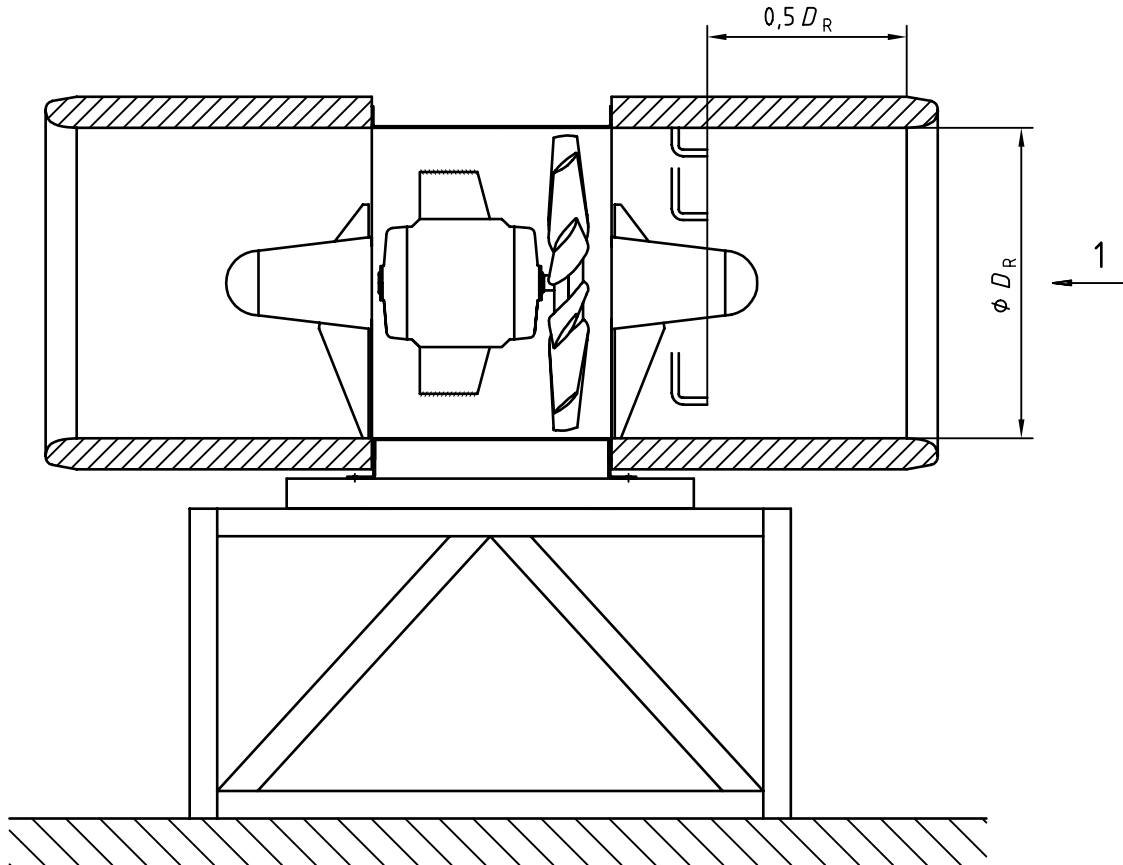

Key

- 1 Air flow

Figure 11 — Flow-measuring installation (upstream Pitot traverse)

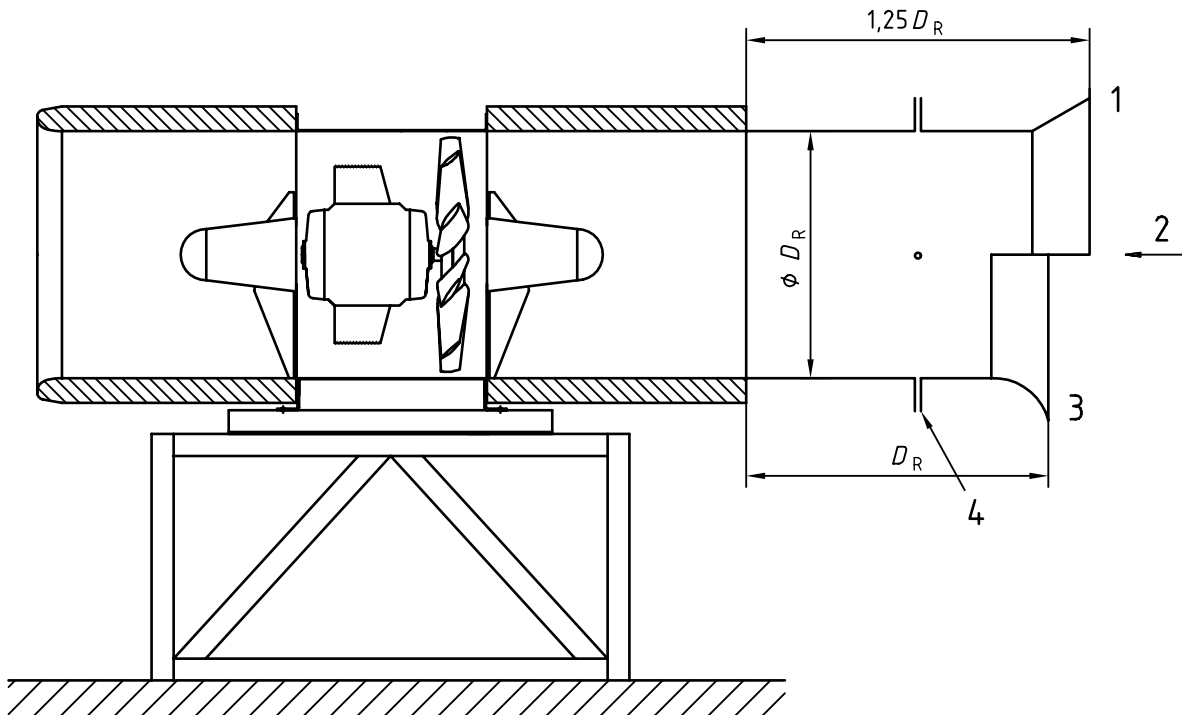

Key

- 1 Conical inlet
- 2 Air flow
- 3 Venturi nozzle
- 4 Side tapings

Figure 12 — Flow-measuring installation (direct connection)

11 Presentation of results

11.1 Product description

The product description shall include at least the following information:

- a) model reference;
- b) size of fan;
- c) rotational speed;
- d) motor output rating and frame size;
- e) electrical supply data;
- f) high temperature operating capability;
- g) overall dimensions;
- h) mounting dimensions;
- i) fan assembly mass;
- j) accessories, e.g. guards, vibration isolators;
- k) condition monitoring equipment.

11.2 Product performance

The performance of the product described in 11.1, which can be given as a listing, shall include at least the following information:

- a) thrust;
- b) effective fan outlet velocity (see note 1 below);
- c) motor input power;
- d) maximum open inlet or open outlet sound power levels (see note 2 below);
- e) maximum upstream and downstream vibration velocities.

By agreement with the client, the data may be provided for “forward” and “reverse” operations.

It shall always be made clear which accessories were fitted when the performance tests were undertaken

NOTE 1 The effective fan outlet velocity v_{eff} is used to calculate the correction factor k on the thrust due to the mainstream tunnel velocity v_t in the tunnel, where:

$$k = \frac{v_{\text{eff}} - v_t}{v_{\text{eff}}}$$

v_{eff} can best be defined as :

$$v_{\text{eff}} = \left| \frac{T_m}{A_{\text{eff}} \cdot \rho_a} \right|^{\frac{1}{2}}$$

For definition of A_{eff} , fan outlet area, see 3.2.

NOTE 2 It may be preferred, by agreement with the client, to present sound level data in an alternative form. For example, as an A-weighted spherical sound pressure level at 10 m or 3 m, 45° in free field.

Also by agreement with the client it shall be decided whether the sound level is given as a single total figure or in each octave band.

NOTE 3 If required for contractual reasons, the flowrate may be determined by one of the methods given clause 10.

12 Tolerances and conversion rules

12.1 Tolerances

The performance quoted is the most probable performance, not the minimum or maximum value. The tolerance values apply to jet fans operating without external resistance and as tested in accordance with this International Standard.

As shown in table 3, the tolerances are intended to take into account measurement uncertainty and manufacturing variations. When direct test results are not available, see annex C.

The effects described in the notes to table 3 are responsible for the large tolerances given in table 3, in order to save complicated correction procedures. Addition of these uncertainties may give rise in certain cases to a total tolerance on the absorbed power of more than the 5 % stated.

12.2 Conversion rules

The conversion rules recommended in annex C apply to fan assemblies with geometric similarity. In the case of jet fans, this means similarity of the following features:

- a) silencer lengths;
- b) silencer pod geometry;
- c) silencer bellmouth shape;
- d) impeller hub ratio;
- e) impeller spinner profile;
- f) blade shape and solidity;
- g) blade setting angle;
- h) motor support design;
- i) motor size;
- j) blade tip clearance (smoke-venting designs).

It is accepted that, for practical reasons, it is not reasonable for every configuration of fan to be subjected to a direct test. Also, perfect geometric similarity is not always readily achievable. Nonetheless it is incumbent on the manufacturer to authenticate any conversion rules used.

Application of conversion rules shall be limited as follows when calculating the performance of another fan from direct test and allowing for some departure from geometric similarity.

Fan size : \pm one R20 step

Rotational speed : test speed \times 1,3 or test speed / 1,3.

Table 3

Measured parameter	Measurement uncertainty	Manufacturing variation	Notes
FAN			
Thrust	± 5 %	± 1 %	1
Effective fan outlet velocity	± 10 %	± 3 %	1,2
Input power	± 2 %	± 3 %	5
Sound level	—	—	3
MOTOR			
1 Efficiency η_M ^a By summation of losses : — machines up to 50 kW — machines above 50 kW By input-output test		— 15 % of $(1 - \eta_M)$ — 10 % of $(1 - \eta_M)$ — 15 % of $(1 - \eta_M)$	
2 Total losses ^a (applicable to machines above 50 kW)		+ 10 % of the total losses	
3 Power factor, $\cos \phi$, for induction machines		— 0,167(1 - $\cos \phi$)	minimum 0,02 maximum 0,07
4 Slip of induction motors (at full load and at working temperature) — machines having output 1 kW (or kVA) or more — machine having output less than 1 kW (or kVA) Speed of a.c. motors with shunt characteristics (at full load and at working temperature)		± 20% of the guaranteed slip ± 30% of the guaranteed slip ■ On the highest speed: — 3% of the synchronous speed ■ On the lowest speed : + 3% of the synchronous speed	
<p>^a The determination of efficiency and losses is carried out in accordance with IEC 60034-2.</p> <p>NOTE 1 It should be noted that whilst thrust is measured, the effective fan outlet velocity is calculated from the thrust using density and conventionalized fan outlet area.</p> <p>NOTE 2 The relatively large uncertainty of the effective fan outlet velocity will, in most cases, have little practical importance in relation to the thrust to be installed in the tunnel, as it only concerns a secondary correction factor.</p> <p>NOTE 3 Uncertainty of measurement of broadband sound levels is given in table 1 of ISO 13347:—¹). To allow for manufacturing deviations, a further 3 dB is added.</p> <p>NOTE 4 It may take some time (say between 1 min and 15 min) before the airflow pattern in the test chamber becomes fully developed. During this time the fan thrust will fall below its initial value. Additionally, the fan thrust may show pronounced erratic variations with time, which may be caused mainly by turbulence and thermal effects in the movement of air in the chamber, variations of supply voltage, etc.</p> <p>The measuring equipment should preferably automatically form r.m.s. values over a duration of at least 3 min. The reading is recorded when variations from period to period no longer occur which are greater than 0,5 times the measuring tolerances in the case of thrust, power consumption, wind speed or direction.</p> <p>NOTE 5 The prediction accuracy of the input power is limited by the manufacturing variations to be expected for the electric motors. These are given in IEC 60034-1. The 1994 version gives a tolerance on the motor efficiency of — 0,15 $(1 - \eta_M)$ for machines having less than 50 kW shaft power. For larger machines this tolerance is reduced to — 0,10 $(1 - \eta_M)$. This is not the only tolerance, when the absorbed power is considered. For motors above 1 kW (or kVA) the permissible slip tolerance at full load and at rated temperature (normally 40 °C) is equal to ± 20 % of the guaranteed slip. As the absorbed shaft power of a fan varies with the cube of the speed, this may lead to considerable variations of the input power and aerodynamic duty.</p> <p>The tolerance of the power factor $\cos \phi$ is given as — 0,167 $(1 - \cos \phi)$, minimum — 0,02, maximum — 0,07.</p> <p>NOTE 6 Motor losses, motor speed and power factor depend on the motor temperature. The name plate data are normally based on a 40 °C chamber temperature, plus the motor temperature rise at full load with normal motor cooling.</p> <p>These conditions do not normally prevail with a jet fan. The load can differ from normal and the high air speed and an air temperature normally well below 40 °C will result in lower motor temperatures. This will cause lower winding temperatures, higher currents and also a variation of speed and cosinus. Furthermore, steady state conditions will take some time to be established. Of course, the tolerances of electric motor data given in IEC 60034-1 should also be respected.</p>			

Annex A (informative)

Illustration of reference sound source

If a calibrated reference sound source is not commercially available, an impeller manufactured in accordance with figure A.1 and correctly calibrated may be used.

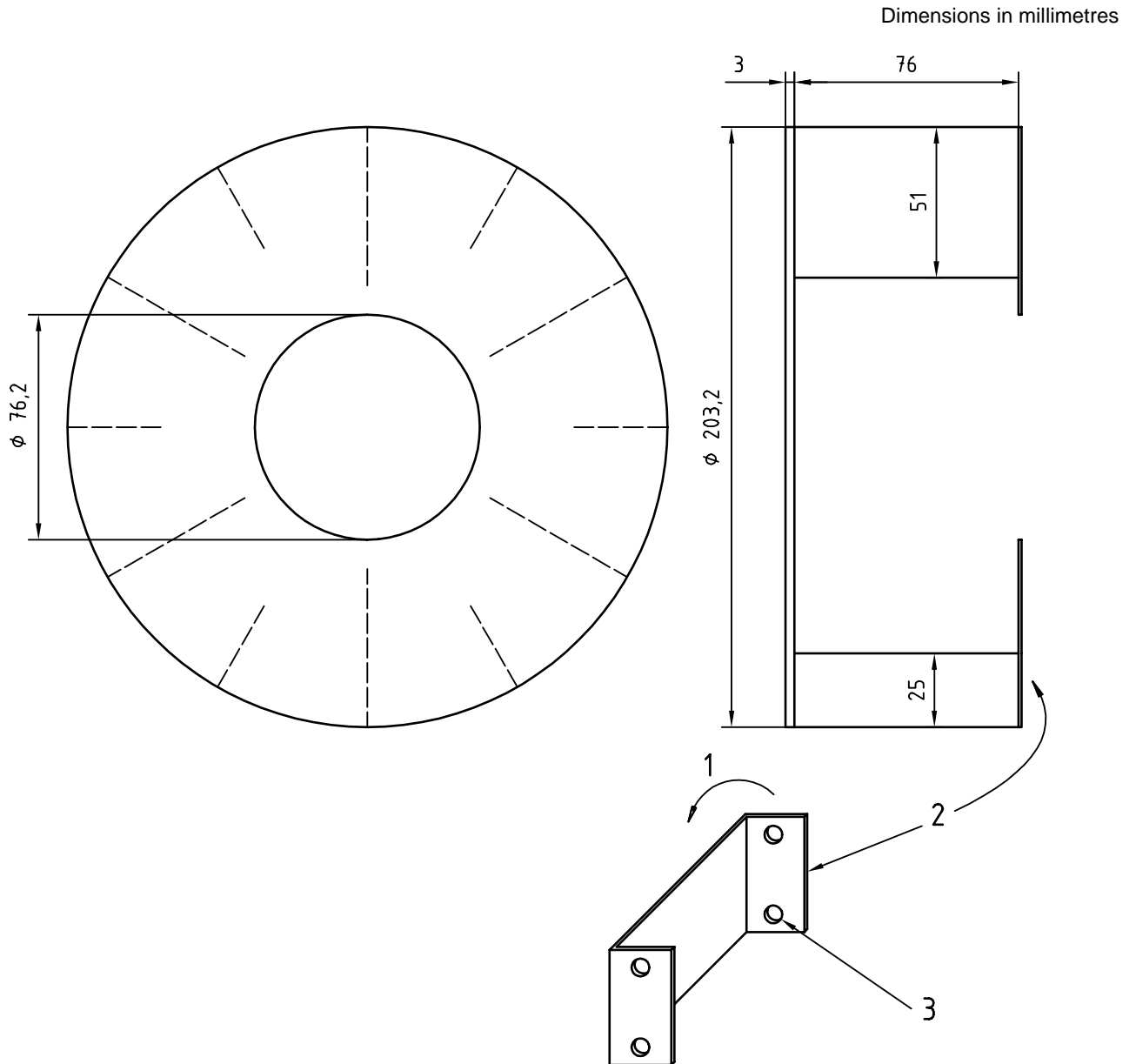

Key

- 1 Rotation
- 2 Mild steel sheet, thickness 1 mm
- 3 Securely rivetted

Figure A.1 — Blade detail

Annex B (informative)

Correction of sound pressure levels

When the sound pressure level with the fan running exceeds by 10 dB or more the background noise with the fan stopped, no correction need be applied.

When the difference is less than 10 dB, corrections as given in table B.1 should be applied.

Table B.1

Increase in dB level produced by the fan	dB to be subtracted from the measured value
6 to 9	1
10 or more	0

When the increase is less than 3 dB, in general the measurements are no longer significant.

Annex C (informative)

Conversion rules

C.1 General

The following conversion rules, subject to agreement between the supplier and client, shall be used when deriving the performance of a fan which has not been directly tested. Conversions is, in the main, based on the use of dimensionless coefficients. A different procedure is used for sound levels.

C.2 Performance coefficients

C.2.1 Flow coefficient

$$\phi = \frac{q_v}{A_a \cdot u}$$

where

A_a is the impeller annulus area;

u is the impeller tip speed ($= \pi \cdot D_R \cdot N$)

C.2.2 Thrust coefficient

$$\theta = \frac{2 \cdot T_C}{A_a \cdot \rho \cdot u^2} \quad (\text{see note 2 below}).$$

C.2.3 Power coefficient

$$\Phi = \frac{2 \cdot T_C}{A_a \cdot \rho \cdot u^3}$$

NOTE 1 T_C should not be calculated from $\rho \cdot q_V \cdot v_{\text{eff}}$. Gross errors may arise from using this formula, principally due to the non-uniformity of velocity at the fan outlet and a lack of certainty as to the effective outlet area of the fan.

NOTE The above performance coefficients differ from those in ISO 5801 but have been found to give good correlation of test data for axial flow jet fans.

C.2.4 Sound power level

Total sound power levels shall be converted according to the following relationship (see note below).

$$L_{wc} = L_{wt} + 50 \log_{10} \frac{N_c}{N_t} + 70 \log_{10} \frac{D_{Rc}}{D_{Rt}}$$

where

N_c is the calculated rotational speed,

N_t is the test rotational speed.

D_{Rc} is the calculated nominal fan diameter,

D_{Rt} is the test nominal fan diameter,

NOTE If the above relationship is used to calculate octave band sound level, then suitable adjustments should be made if the blade passing frequency changes to an octave band different than that for the test fan.

Annex D (informative)

Bibliography

- [1] ISO 3744:1994, *Acoustics — Determination of sound power levels of noise sources using sound pressure — Engineering method in an essentially free field over a reflecting plane.*
- [2] IEC 60034-1:1996, *Rotating electrical machines — Part 1: Rating and performance.*

ICS 23.120

Price based on 25 pages
