

---

---

**Tyres — Coast-by methods for  
measurement of tyre-to-road sound  
emission**

*Pneumatiques — Méthodes en roue libre pour le mesurage de  
l'émission acoustique issue du contact pneumatique/chaussée*



**PDF disclaimer**

This PDF file may contain embedded typefaces. In accordance with Adobe's licensing policy, this file may be printed or viewed but shall not be edited unless the typefaces which are embedded are licensed to and installed on the computer performing the editing. In downloading this file, parties accept therein the responsibility of not infringing Adobe's licensing policy. The ISO Central Secretariat accepts no liability in this area.

Adobe is a trademark of Adobe Systems Incorporated.

Details of the software products used to create this PDF file can be found in the General Info relative to the file; the PDF-creation parameters were optimized for printing. Every care has been taken to ensure that the file is suitable for use by ISO member bodies. In the unlikely event that a problem relating to it is found, please inform the Central Secretariat at the address given below.

© ISO 2003

All rights reserved. Unless otherwise specified, no part of this publication may be reproduced or utilized in any form or by any means, electronic or mechanical, including photocopying and microfilm, without permission in writing from either ISO at the address below or ISO's member body in the country of the requester.

ISO copyright office  
Case postale 56 • CH-1211 Geneva 20  
Tel. + 41 22 749 01 11  
Fax + 41 22 749 09 47  
E-mail [copyright@iso.org](mailto:copyright@iso.org)  
Web [www.iso.org](http://www.iso.org)

Published in Switzerland

**Contents**

Page

<b>Foreword</b> .....	<b>iv</b>
<b>1 Scope</b> .....	<b>1</b>
<b>2 Normative references</b> .....	<b>1</b>
<b>3 Terms and definitions, symbols and abbreviated terms</b> .....	<b>1</b>
<b>4 General</b> .....	<b>2</b>
<b>5 Test site</b> .....	<b>2</b>
<b>6 Instrumentation</b> .....	<b>3</b>
<b>7 Meteorological conditions and background sound</b> .....	<b>4</b>
<b>8 Preparation and adjustments with respect to tyres</b> .....	<b>5</b>
<b>Annex A (normative) Vehicle method</b> .....	<b>6</b>
<b>Annex B (normative) Trailer method</b> .....	<b>12</b>
<b>Bibliography</b> .....	<b>23</b>

## Foreword

ISO (the International Organization for Standardization) is a worldwide federation of national standards bodies (ISO member bodies). The work of preparing International Standards is normally carried out through ISO technical committees. Each member body interested in a subject for which a technical committee has been established has the right to be represented on that committee. International organizations, governmental and non-governmental, in liaison with ISO, also take part in the work. ISO collaborates closely with the International Electrotechnical Commission (IEC) on all matters of electrotechnical standardization.

International Standards are drafted in accordance with the rules given in the ISO/IEC Directives, Part 2.

The main task of technical committees is to prepare International Standards. Draft International Standards adopted by the technical committees are circulated to the member bodies for voting. Publication as an International Standard requires approval by at least 75 % of the member bodies casting a vote.

Attention is drawn to the possibility that some of the elements of this document may be the subject of patent rights. ISO shall not be held responsible for identifying any or all such patent rights.

ISO 13325 was prepared by Technical Committee ISO/TC 31, *Tyres, rims and valves*.

# Tyres — Coast-by methods for measurement of tyre-to-road sound emission

## 1 Scope

This International Standard specifies methods for measuring tyre-to-road sound emissions from tyres fitted on a motor vehicle or towed trailer under coast-by conditions — i.e. when the vehicle or trailer is in free-rolling, non-powered operation, with transmission in the neutral position and the engine as well as all auxiliary systems not necessary for safe driving switched off. Whereas the results of the vehicle method could be higher than for the tyres alone, the trailer method can be expected to give a good indication of the sound emissions produced by the tyres alone.

This International Standard is applicable to passenger cars and commercial vehicles as defined in ISO 3833. It is not intended to be used to determine the sound contribution of tyres of vehicles running in powered condition nor for the determination of traffic sound nuisance at a given location.

## 2 Normative references

The following referenced documents are indispensable for the application of this document. For dated references, only the edition cited applies. For undated references, the latest edition of the referenced document (including any amendments) applies.

ISO 4223-1, *Definitions of some terms used in the tyre industry — Part 1: Pneumatic tyres*

ISO 10844, *Acoustics — Specification of test tracks for the purpose of measuring noise emitted by road vehicles*

IEC 60651:2001, *Sound pressure level meters*

IEC 60942:1997, *Electroacoustics — Sound calibrators*

## 3 Terms and definitions, symbols and abbreviated terms

For the purposes of this document, the terms and definitions in ISO 4223-1 and the following symbols and abbreviated terms apply.

### 3.1 Classes of tyre

- C1 Passenger car tyres
- C2 Commercial vehicle tyres with LI in single formation lower or equal to 121 and speed category symbol higher or equal to “N”.
- C3 Commercial vehicle tyres with a LI in single formation lower or equal to 121 and speed category symbol “M” and below, or such tyres with a LI in single formation 122 and higher.

### 3.2 LI (load index)

The LI is a numerical code associated with the maximum load a tyre can carry at the speed indicated by its speed symbol under the service conditions specified by the tyre manufacturer. In cases where the LI consists of two numbers, reference shall be made to the first number. For tyres where the load index is not available, reference shall be made to the maximum load marked on the tyre sidewall.

## 4 General

This International Standard is based on a test using a test motor vehicle (see Annex A) or towed trailer (see Annex B) in motion. Measurements shall relate to tyres in coast-by conditions.

The results obtained give an objective measure of the sound emitted under the prescribed conditions of the test.

## 5 Test site

The test site shall consist of a substantially flat and level area. Conditions of a free acoustical field between the sound source and the microphone shall be attained to within 1 dB. These conditions shall be deemed to be met if there are no large sound reflecting objects, such as fences, barriers, bridges or buildings, within 50 m of the centre of the test area.

The test surface, including voids, shall be dry and clean for all measurements. The test area and surface shall meet the requirements of ISO 10844. See Figure 1.

Dimensions in metres

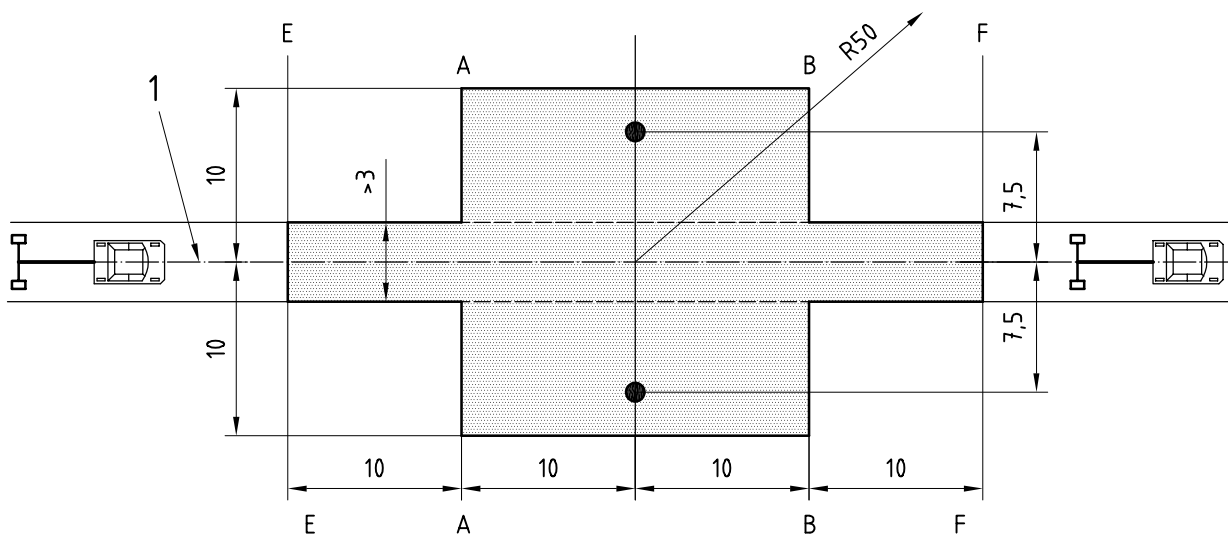

### Key

1 centreline of travel

● microphones location

A–A, B–B, E–E and F–F are reference lines

NOTE Travel of the vehicle (see Annex A) or trailer (see Annex B) is as appropriate.

Figure 1 — Test area and surface

## 6 Instrumentation

### 6.1 Instrumentation for acoustical measurements

The sound pressure level meter or equivalent measuring system shall at least meet the requirements of a Type 1 instrument in accordance with IEC 60651:2001.

The measurements shall be made using the frequency weighting, A, and the time weighting, F.

The calibration of the sound pressure level meter shall be checked and adjusted in accordance with the manufacturer's instructions or with a standard sound source (e.g. pistonphone) at the beginning of the measurements and rechecked and recorded at the end of them. The calibration device shall meet the requirements of Class 1 in accordance with IEC 60942:1997.

If the sound pressure level meter indications obtained from these calibrations differ by more than 0,5 dB during a series of measurements, the test shall be considered invalid. Any deviation shall be recorded in the test report.

At intervals of not more than one year, the sound pressure level meter and the calibration device shall be verified with the requirements of IEC 60651 and IEC 60942.

Windscreens shall be used in accordance with the microphone manufacturer's recommendations.

The test area and surface shall be in accordance with ISO 10844, as shown in Figure 1. Additionally, there shall be no large acoustically reflective objects within the radius shown in Figure 1.

### 6.2 Microphones

Two microphones shall be used in the test, one on each side of the vehicle/trailer. In the vicinity of the microphones, there shall be no obstacle that could influence the acoustical field and no person shall remain between the microphones and the sound source. Any observer or observers shall be positioned so as not to influence the sound reading.

The distance from the microphone positions to the centreline of travel on the test track shall be  $(7,5 \pm 0,05)$  m. Each microphone shall be located  $(1,2 \pm 0,02)$  m above the test area surface and shall be oriented as recommended by the manufacturer of the sound pressure level meter for field conditions for a test vehicle passing along the centreline of travel as shown in Figure 1.

### 6.3 Temperature measurement

#### 6.3.1 General

For air as well as test surface temperature, the measuring instrument shall have an overall accuracy of at least  $\pm 1$  °C. Meters utilizing the infrared technique shall not be used for air temperature measurements.

The type of sensor shall be reported.

Continuous registration via an analog output may be employed. If such an option is not available, single values are to be measured.

Measurements of air as well as test surface temperatures are mandatory and shall be made in accordance with the instrument manufacturer's instructions. The results are the readings rounded to the nearest integer in degrees Celsius.

Temperature measurements shall correspond reasonably over time with sound measurements. Alternatively, the average of the temperature at the beginning and the end of the set of tests may be used, in both vehicle and trailer methods.

### 6.3.2 Air temperature

Position the temperature sensor in an unobstructed location close to the microphone, such that it is exposed to the airflow and protected from direct solar radiation. The latter may be achieved by any shading screen or similar device. The sensor should be positioned 1,0 m to 1,5 m above the test surface level, to minimize the influence of the test surface thermal radiation at low airflows.

### 6.3.3 Test surface temperature

Position the temperature sensor in a location where the temperature is representative of the temperature in the wheel tracks, without interfering with the sound measurement.

If an instrument with a contact temperature sensor is used, apply heat-conductive paste between the surface and the sensor to ensure adequate thermal contact.

If a radiation thermometer (pyrometer) is used, the height should be chosen to ensure that a measuring spot with a diameter of  $\geq 0,1$  m is covered.

The test surface shall not be artificially cooled during or prior to testing.

## 6.4 Wind measurement

The device shall be capable of measuring wind speed to within  $\pm 1$  m/s. Wind measurements shall be taken at microphone height, between Lines A–A and B–B and not more than 20 m from the centreline of travel (see Figure 1). The wind direction with reference to the driving direction shall be recorded.

## 6.5 Speed measurement

The speed measuring device shall be capable of measuring test motor vehicle or towed trailer speed to within a tolerance of  $\pm 1$  km/h.

## 7 Meteorological conditions and background sound

### 7.1 Meteorological conditions

Measurements shall not be made in adverse weather conditions and shall not be affected by gusts of wind. Testing shall not be performed if the wind speed at the microphone height exceeds 5 m/s. Measurements shall not be made if either the air or test surface temperatures are below 5 °C or the air temperature is above 40 °C.

### 7.2 Temperature correction

Temperature correction shall be applied only for C1 and C2 tyres. Each measured sound pressure level,  $L_m$ , shall be corrected using the following formula:

$$L = L_m + K\Delta T$$

where

$L$  is the corrected sound pressure level;

$K$  is the coefficient that

- for C1 tyres is equal to  $-0,03$  dB (A-weighted)/°C when the measured test surface temperature is  $> 20$  °C and  $-0,06$  dB (A-weighted)/°C when the measured test surface temperature is less than 20 °C; and



— for C2 tyres, is equal to  $-0,02$  dB (A-weighted)/°C;

$\Delta T$  is the difference between the reference surface temperature, 20 °C, and the surface temperature,  $t$ , at the time of the sound recording,

$$\Delta T = (20 - t) \text{ °C.}$$

### 7.3 Background sound pressure level

The background sound pressure level (including any wind noise) shall be at least 10 dB less than the measured tyre-road sound emission.

A suitable windscreen may be fitted to the microphone provided that account is taken of its effect on the sensitivity and directional characteristics of the microphone.

## 8 Preparation and adjustments with respect to tyres

Test tyres shall be mounted on any rim approved by the tyre manufacturer. The rim width shall be recorded. Tyres with special fitment requirements, such as asymmetric or directional design, shall also be mounted in accordance with these requirements.

The tyre/rim assembly shall be balanced. Before testing, tyres shall be conditioned (broken-in). Tyre break-in shall be equivalent to about 100 km of normal on-road operation. Tyres with special fitment requirements shall be broken-in in accordance with these requirements.

Apart from the tread wear caused by the break-in procedure, the tyres shall have full tread depth.

C1 and C2 test tyres shall be warmed-up immediately prior to testing in conditions equivalent to 10 min at 100 km/h of normal driving.

## **Annex A** (normative)

### **Vehicle method**

#### **A.1 General**

##### **A.1.1 Test vehicle**

The test motor vehicle shall have two axles with two test tyres on each axle. It shall be loaded to obtain tyre loads in accordance with A.1.4.

##### **A.1.2 Wheel base**

The wheelbase between two axles fitted with test tyres shall be

- a)  $\leq 3,5$  m for C1 tyres, and
- b)  $\leq 5,0$  m for C2 and C3 tyres.

##### **A.1.3 Other measures to minimize vehicle influence on measurements**

In order to ensure that tyre sound is not significantly affected by the test vehicle design, the following requirements and recommendations are given.

###### **a) Requirements**

- 1) Spray suppression flaps or other extra devices to suppress spray shall not be fitted.
- 2) The addition or retention of elements in the immediate vicinity of the rims and tyres, which may screen the emitted sound, is not permitted.
- 3) Wheel alignment (toe-in, camber and caster) shall be checked on the unladen vehicle and found to be in full accordance with the vehicle manufacturer's recommendations.
- 4) Additional sound-absorbing material shall not be mounted in the wheel housings or on the underbody.
- 5) The windows and sliding roof of the vehicle shall be closed during testing.

###### **b) Recommendations for avoiding parasitic sound**

- 1) Components on the vehicle that could contribute to the background sound of the vehicle should be modified or removed. Any removals or modifications are to be recorded in the test report.
- 2) During testing it should be ascertained that brakes are not poorly released, causing brake noise.
- 3) Four-wheel-drive vehicles and trucks with reduction gears in the axles should not be used.
- 4) The good condition of suspensions should be such that they do not result in an abnormal reduction in ground clearance when the vehicle is loaded in accordance with the testing requirement. If available, body level regulation systems should be adjusted to give ground clearance during testing normal for the unladen condition.

- 5) Before testing, the vehicle should be washed clean of any mud, dirt or sound-absorbing material inadvertently added during the break-in period.

#### A.1.4 Tyre load

The vehicle method load conditions shall meet all the following conditions.

- a) The average load of all tyres shall be  $(75 \pm 5)$  % of their LI.
- b) No tyre shall be loaded to less than 70 % or more than 90 % of its LI.

#### A.1.5 Tyre inflation pressure

Each tyre shall be inflated to a cold inflation pressure of  $P_t + 10\%$  :

$$P_t = P_r \left( \frac{Q_t}{Q_r} \right)^{1,25}$$

where

$P_t$  is the test inflation pressure, in kilopascals;

$P_r$  is the reference pressure, which,

— for a standard C1 tyre, equals 250 kPa, and

— for a reinforced C1 tyre, equals 290 kPa,

and for both of which the minimum test inflation pressure shall be  $P_t = 150$  kPa, and

— for C2 and C3 tyres is the pressure marked on the tyre sidewall;

$Q_r$  is the reference load, corresponding to the maximum mass associated with the LI of the tyre;

$Q_t$  is the test load for the tyre.

#### A.1.6 Vehicle operating condition

The test vehicle shall approach Line A–A or Line B–B with the engine off and the transmission in neutral position, and with the vehicle centre following as closely as possible the “centreline of travel”, as shown in Figure 1.

#### A.1.7 Speed range

The test vehicle speed at the time when it is at a position perpendicular to the microphones, shall be in the range of

- a) 70 km/h to 90 km/h for C1 and C2 tyres, and
- b) 60 km/h to 80 km/h for C3 tyres.

For reference speeds, see A.2.2.

### A.1.8 Sound pressure level readings

The maximum sound pressure level indicated for both microphones during each passage of the test vehicle between the Lines A–A and B–B shall be recorded.

The measurement shall be invalid if an abnormal discrepancy between the peak value and the general sound pressure level is recorded, provided such a peak is not repeatable if more measurements are made at the same speed.

NOTE Some tyres may give peaks (“resonances”) at certain speeds.

### A.1.9 Number of measurements

For each microphone location (each side), there shall be at least four measurements at a test speed higher than reference speed (see A.2.2), and at least four measurements at a test speed lower than the reference speed. The speeds shall be approximately equally spaced over the speed range given in A.1.7.

### A.1.10 Recommended frequency spectrum measurement

The one-third-octave band frequency spectrum should also be measured. The averaging time should correspond to F. The spectrum should be captured when the A-weighted sound pressure level during a vehicle pass-by is at its maximum.

## A.2 Data processing

### A.2.1 Temperature correction

See 7.2.

### A.2.2 Reference speeds

In order to normalize sound with respect to speed, a reference speed,  $v_{\text{ref}}$ , of

- 80 km/h for C1 and C2 tyres, and
- 70 km/h for C3 tyres,

shall be used.

### A.2.3 Normalization with respect to speed

With each valid pair of measured values (test speed  $v_i$ , temperature corrected sound pressure level  $L_i$ ), the determination of the test result for the reported tyre–road sound pressure level  $L_R$  shall be obtained by a regression analysis using the formula

$$L_R = \bar{L} - a\bar{v}$$

where

$\bar{L}$  is the arithmetic mean value of temperature corrected sound pressure levels, in decibels, with

$$\bar{L} = \left(\frac{1}{n}\right) \sum_{i=1}^n L_i$$

where  $n$  is the number of corrected sound pressure levels and  $n \geq 16$ , using the results for both microphones in the same regression analysis;

$\bar{v}$  is the arithmetic mean value of the logarithm of speeds, with

$$\bar{v} = (1/n) \sum_{i=1}^n v_i$$

where

$$v_i = \lg \left( \frac{v_i}{v_{\text{ref}}} \right)$$

$a$  is the slope of the regression line, in decibels per speed decade, with

$$a = \frac{\sum_{i=1}^n (v_i - \bar{v})(L_i - \bar{L})}{\sum_{i=1}^n (v_i - \bar{v})^2}$$

This gives the reported tyre-to-road sound pressure level,  $L_R$ . Then, optionally, the level at any other speed,  $L_v$ , (within the speed range), can be determined as

$$L_v = L_R + a \lg \left( \frac{v}{v_{\text{ref}}} \right)$$

### A.3 Test report

The test report shall include the following information:

- a) reference to this International Standard;
- b) meteorological conditions, which shall include the ambient air and surface temperature for each run;
- c) when and how compliance of the test surface with ISO 10844 was checked;
- d) test rim width;
- e) tyre data, including manufacturer, brand name, trade name, size, LI or load capacity, speed symbol, reference pressure, and serial number of the tyre;
- f) test vehicle type and make, vehicle year model and information about any modifications to the vehicle related to sound;
- g) tyre load in kilograms and in percent of the LI for each test tyre;
- h) cold inflation pressure in kilopascals for each test tyre;
- i) test speeds at which the vehicle passed the microphones;
- j) maximum A-weighted sound pressure levels for each coast-by and each microphone;
- k) maximum A-weighted sound pressure level, in decibels, normalized to the reference speed and corrected for temperature, expressed to at least one decimal place.

Tables A.1, A.2 and A.3 present — respectively — the format of information for a test report, a background data form designed for use with either motor vehicle or trailer method, and a motor vehicle test results form.

Table A.1 — Test report

Coast-by testing of tyres with respect to sound emission, in accordance with ISO 13325	
Test Report No.: _____	
Tyre make (trade name, brand name, manufacturer): _____	
Manufacturer tyre range trade description(s): _____	
Address(es) of tyre manufacturing plant(s): _____	
Size of tyre: _____ Tyre serial number: _____	
Tyre load index (LI) and speed symbol: _____ Ref. pressure: _____	
Class of tyre: (mark one box)	<input type="checkbox"/> Passenger car (C1) <input type="checkbox"/> Commercial vehicle (C2) <input type="checkbox"/> Commercial vehicle (C3)
Category of use: _____	
Enclosures to this report: _____	
Reported A-weighted sound pressure level: _____ dB, at reference speed of: <input type="checkbox"/> 70 km/h <input type="checkbox"/> 80 km/h	
Comments (if any): _____	
Technical service responsible for carrying out the tests: _____	
Name and address of applicant: _____	
Date of test report: _____ Signature: _____	

**Table A.2 — Background data/information on tyre–road sound tests**

This form belongs to Test Report No.: \_\_\_\_\_ Date of sound testing: \_\_\_\_\_

Test vehicle/trailer (type, make, year model, modifications, draw bar length): \_\_\_\_\_

\_\_\_\_\_

Location of test track: \_\_\_\_\_ Date of track certification: \_\_\_\_\_

Test track certification available at: \_\_\_\_\_

\_\_\_\_\_

Tyre test load in kg, front left: \_\_\_\_\_ front right: \_\_\_\_\_ rear left: \_\_\_\_\_ rear right: \_\_\_\_\_

Same, in % of LI, front left: \_\_\_\_\_ front right: \_\_\_\_\_ rear left: \_\_\_\_\_ rear right: \_\_\_\_\_

Tyre inflation in kPa, front left: \_\_\_\_\_ front right: \_\_\_\_\_ rear left: \_\_\_\_\_ rear right: \_\_\_\_\_

Test rim width: \_\_\_\_\_

Temperature measuring sensor type \_\_\_\_\_ Air: \_\_\_\_\_; Test surface: \_\_\_\_\_

**Table A.3 — Motor vehicle test results**

Test No.	Speed km/h	Running direction	Sound pressure level left side (not temp. corrected)	Sound pressure level right side (not temp. corrected)	Air temp. °C	Road temp. °C	Sound pressure level left side (corrected)	Sound pressure level right side (corrected)	Comments
			dB (A-weighted)	dB (A-weighted)			dB (A-weighted)	dB (A-weighted)	
1									
2									
3									
4									
5									
6									
7									
8									
Reported A-weighted sound pressure level: _____ dB									
NOTE Reported A-weighted sound pressure level is to be calculated at the reference speed utilizing regression analysis, after temperature corrections and rounded to the nearest tenth of a decibel.									

## **Annex B** (normative)

### **Trailer method**

#### **B.1 Towing vehicle and trailer**

##### **B.1.1 General**

The test apparatus shall consist of two parts: the towing vehicle and the trailer.

##### **B.1.1.1 Towing vehicle**

###### **B.1.1.1.1 Sound pressure level**

The rolling sound of the towing vehicle can be minimized by appropriate measures (low-noise tyres, shielding, aerodynamic skirting, etc.). In the ideal case the sound pressure level of the towing vehicle alone is at least 10 dB (A-weighted) below the level for the combination of the towing vehicle and the trailer. For such cases, multiple measurements with towing vehicle alone are not necessary. Since subtraction of the towed vehicle is not required, improved measurement accuracy is possible. The required level differences and the derived tyre sound pressure levels are given in B.4.

###### **B.1.1.1.2 Loading**

There shall be no load change on the towing vehicle tyres between the test pass of the towing vehicle trailer combination and the towing vehicle alone. To achieve consistent loading, adding ballast to the towing vehicle during towing-vehicle-alone tests could be necessary.

##### **B.1.1.2 Trailer**

###### **B.1.1.2.1 Single-axle frame trailer**

The trailer shall be a single-axle frame trailer with drawbar and facility for varying wheel load. Superstructures or panelling are to be avoided in order to minimize vehicle-specific influences. Tyres shall be exposed with no tyre housing or covers.

###### **B.1.1.2.2 Drawbar length**

The drawbar length for the trailer shall be at least 5 m in length when measured from the centre of the towing vehicle axles to the trailer axle.

###### **B.1.1.2.3 Track width**

The horizontal distance perpendicular to the direction of travel shall be less than 2,5 m. This distance shall be measured between the centres of the contact patch of each trailer tyre.

###### **B.1.1.2.4 Alignment**

Alignment settings (camber and toe-in) of all test tyres shall be zero at test conditions. The tolerance for camber shall be  $\pm 30'$  and the tolerance for toe angle shall be  $\pm 5'$ .



## B.2 Tyre load and pressure

### B.2.1 Tyre load

For tyres of all classes, the test load shall be  $(75 \pm 2)$  % of the reference load  $Q_r$ .

### B.2.2 Tyre inflation pressure

Each tyre shall be inflated to a cold inflation pressure of  $P_t^{+10}_0$  % :

$$P_t = P_r \left( \frac{Q_t}{Q_r} \right)^{1,25}$$

where

$P_t$  is the test inflation pressure, in kilopascals;

$P_r$  is the reference pressure, which,

- for a standard C1 tyre, equals 250 kPa,
- for a reinforced C1 tyre, equals to 290 kPa, and
- for C2 and C3 tyres is the pressure marked on the tyre sidewall;

$Q_r$  is the reference load, corresponding to the maximum mass associated with the LI of the tyre;

$Q_t$  is the test load for the tyre.

## B.3 Measurement procedure

### B.3.1 General

In performing this test, two sets of measurements shall be made.

- a) First, test the towing vehicle alone and record the measured sound pressure levels in accordance with the following procedures.
- b) Then test the towing vehicle-trailer combination and record the resulting sound pressure levels.

For the derivation of the tyre sound pressure levels, see B.4.

### B.3.2 Vehicle position

The towing vehicle or towing vehicle and trailer combination shall approach Line E–E with the engine off, the transmission in neutral and the clutch disengaged, and with the path of the vehicle centreline following as closely as possible the centreline of travel, as shown in Figure 1.

### B.3.3 Test speed

The towing vehicle shall be used to attain sufficient speed prior to entering the test zone (E–E or F–F, see Figure 1), such that, when the towing vehicle engine is switched off and the vehicle and trailer are coasting into the test zone, the average vehicle speed between A–A and B–B shall be  $(80 \pm 1,0)$  km/h for C1 and C2 tyres, and  $(70 \pm 1,0)$  km/h for C3 tyres.

**B.3.4 Readings to be taken**

**B.3.4.1 Sound measurement**

The maximum sound pressure level indicated by microphones during the entire period the test tyres are in the test zone, between Lines A–A and B–B (see Figure B.1), shall be recorded. In addition, the sound pressure level shall be recorded for each microphone with an integration time equivalent to F time weighting at time intervals of no more than 0,01 s during the pass through the measurement section. This latter data set will be known as the time history sound pressure levels in the subsequent discussion.

The time history measurement begins with the definition of Lines A’–A’ and B’–B’ as shown in Figure B.1. These lines are defined as using the length  $d_t$ , the distance from the centre of the test tyre to the trigger point on the towing vehicle (see Figure B.1). The trigger point is the point on the vehicle that will cause a mark on the recorded time scale when it passes A’–A’ and B’–B’. Sound recording begins and ends at these times, respectively. The same recording procedure is used for passes of the towing vehicle-trailer combination and for the towing vehicle alone.

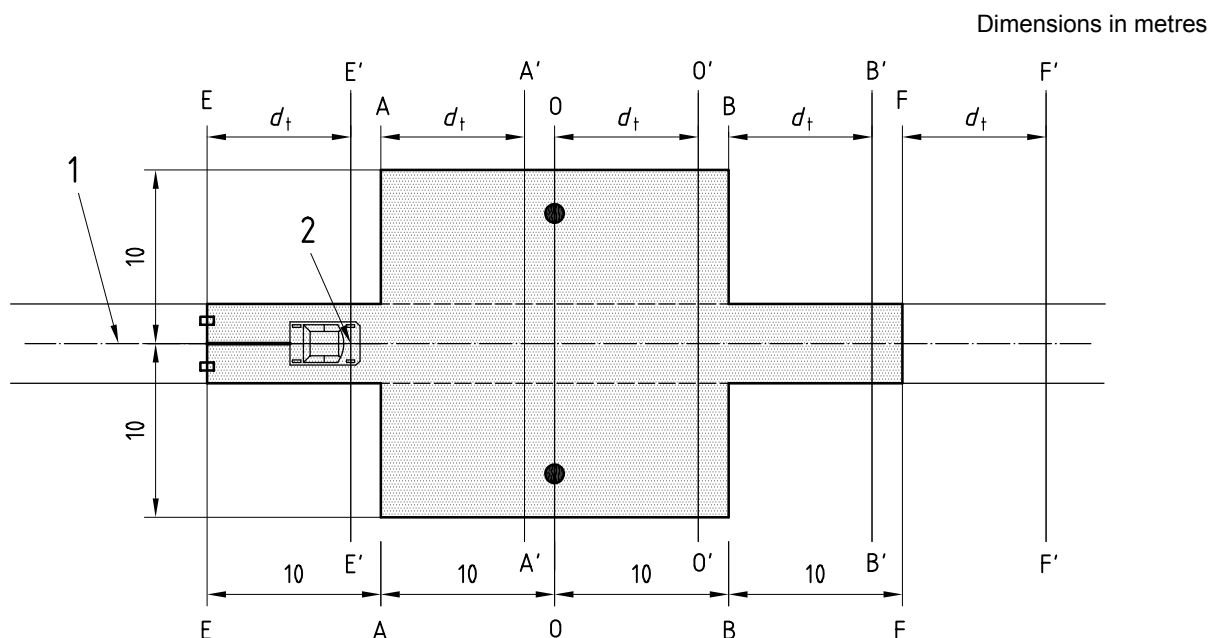

**Key**

- 1 centreline of travel
- 2 trigger point
- microphone location

A–A and A’–A’, B–B and B’–B’, E–E and E’–E’, F–F and F’–F’, and O–O and O’–O’ are reference lines.

**Figure B.1 — Measurement layout for time history calculation**

**B.3.4.2 Additional measurements**

The following data shall also be recorded during each pass:

- a) ambient air temperature;
- b) road surface temperature;
- c) whether wind velocity was below 5 m/s (yes/no);

- d) whether background sound pressure level was at least 10 dB below measured level (yes/no);
- e) average speed of towing vehicle between A'–A' and B'–B'.

### B.3.5 Sound pressure level averages

Record the time history of the overall A-weighted sound pressure levels and the highest level attained during each pass for each microphone position. Continue measurements until five maximum sound pressure levels are within  $\pm 0,5$  dB of their arithmetic average without temperature correction and are recorded for each speed and each microphone position. In accordance with 7.2, these average maximum levels and the average time history levels shall be temperature corrected. Then average the temperature-corrected values obtained for both microphones to determine a microphone-averaged sound pressure level and time history. Next, calculate the arithmetic average of the two microphone-averaged levels for the towing vehicle alone and the tyre-vehicle trailer combination and note the pass average sound pressure level. Follow this same averaging procedure for the time history of the sound pressure level. This will yield an averaged sound pressure level time history to be used in subsequent calculations, where

$\bar{L}_T$  is the average of the maximum sound pressure levels of the towed vehicle without trailer;

$L_T(t)$  is the average time history sound pressure level of the towed vehicle without trailer;

$\bar{L}_{Tp}$  is the average of the maximum sound pressure levels of the test pass (towing vehicle-trailer combination);

$L_{Tp}(t)$  is the average time history sound pressure level of the test pass (towing vehicle-trailer combination).

### B.3.6 Alignment of the time history records

When the towing vehicle crosses Line O'–O' an indicator pulse shall be recorded with the sound pressure level time history records. This indicator pulse shall then be used to ensure proper alignment of signals in time for the necessary averaging and subtraction.

### B.3.7 Test procedure

The step-by-step procedure for conducting the trailer test is as follows.

#### a) Preparation

- 1) Set the timing trigger point on the towing vehicle.
- 2) Measure  $d_t$  (see Figure B.1).
- 3) Determine the location of E'–E', A'–A', O'–O', B'–B' and F'–F' on the test section as shown in Figure B.1. Set the trigger devices so that sound pressure level recording begins at E'–E' and stops at F'–F'.
- 4) The average speed between A–A and B–B shall be  $(80 \pm 1,0)$  km/h for C1 and C2 tyres, and  $(70 \pm 1,0)$  km/h for C3 tyres. Speed is measured in section A–A to B–B for the test tyre, which is equivalent to section A'–A' to B'–B' for the timing indicator on the towing vehicle.
- 5) Set the data recorder so that the time history is always recorded from E'–E' to F'–F' for the solo and combination tests. Set the trigger alignment of time history records in accordance with B.3.6 so that it matches O'–O'.
- 6) Check the air temperature and wind measuring devices.

**b) Solo test (towing vehicle alone) of at least five passes**

- 1) Record the maximum A-weighted sound pressure level and sound pressure level time history attained during each pass for each microphone position. Continue this measurement procedure until five maximum sound pressure levels are within  $\pm 0,5$  dB of their arithmetic average and are recorded for each microphone position.
- 2) Apply the temperature correction to the five time histories with maximum levels within  $\pm 0,5$  dB of their mean.
- 3) Determine the average sound pressure level time history for those five time histories.
- 4) Run this test [b) 1) to 3)] at the beginning and end of each series of tests. The towing vehicle test shall also be performed when there is a change in air temperature of 5 °C or more during a test series.

**c) Combination (towing vehicle and trailer) test of at least five runs**

- 1) Record the maximum A-weighted sound pressure level and sound pressure level time history attained during each pass for each microphone position. Continue this measurement procedure until five maximum sound pressure levels are within  $\pm 0,5$  dB of their arithmetic average and are recorded for each microphone position.
- 2) Apply the temperature correction to the five time histories with maximum levels within  $\pm 0,5$  dB of their mean.
- 3) Determine the average sound pressure level time history for those five time histories.

See Tables B.1 and B.2.

## **B.4 Determination of tyre sound pressure levels**

### **B.4.1 Considering towing vehicle influence**

Before the coast-by tyre sound pressure level can be calculated, tests must be done to ensure a valid computation is possible. There must be sufficient difference between the levels measured for the towing vehicle alone and the towing vehicle-trailer combination for an accurate computation of the tyre sound pressure level. This difference can be checked in the following two ways.

**a) Maximum sound pressure level difference  $\geq 10$  dB**

If the average of the maximum sound pressure levels for the towing vehicle alone is at least 10 dB below the average of the maximum sound pressure levels for the towing vehicle and trailer combination for both microphones, then a valid measurement has been made. This assumes all other restrictions on environmental conditions, background sound, etc. have been met. In this special case, the tyre sound pressure level is the averaged maximum level measured for the towing vehicle and trailer combination. This is shown in the equation:

$$L_{\text{tyre}} = \bar{L}_{\text{Tp}}$$

where  $L_{\text{tyre}}$  is the sound pressure level of the subject tyre (i.e. the level reported).

**b) Maximum sound pressure level difference  $< 10$  dB**

If the average maximum sound pressure level for the towing vehicle alone is less than 10 dB below the level for the towing vehicle and trailer combination for either or both microphones, then a further calculation is required. This calculation uses the averaged time history sound pressure levels corrected.

### B.4.2 Time history sound pressure level computation

The subject tyres' sound pressure levels to be reported are the differences between the averaged sound pressure level of the towing vehicle-trailer combination and the averaged sound pressure level of the towing vehicle alone. To compute this difference, the temperature-corrected averaged sound pressure level time history for the towing vehicle must be subtracted from that for the towing vehicle and trailer combination. The averaged sound pressure levels are calculated from the data obtained for the five runs in which the maximum sound pressure levels are within  $\pm 0,5$  dB of the mean of their maximum levels, as described above. An example of time history sound pressure levels is shown in Figure B.2.

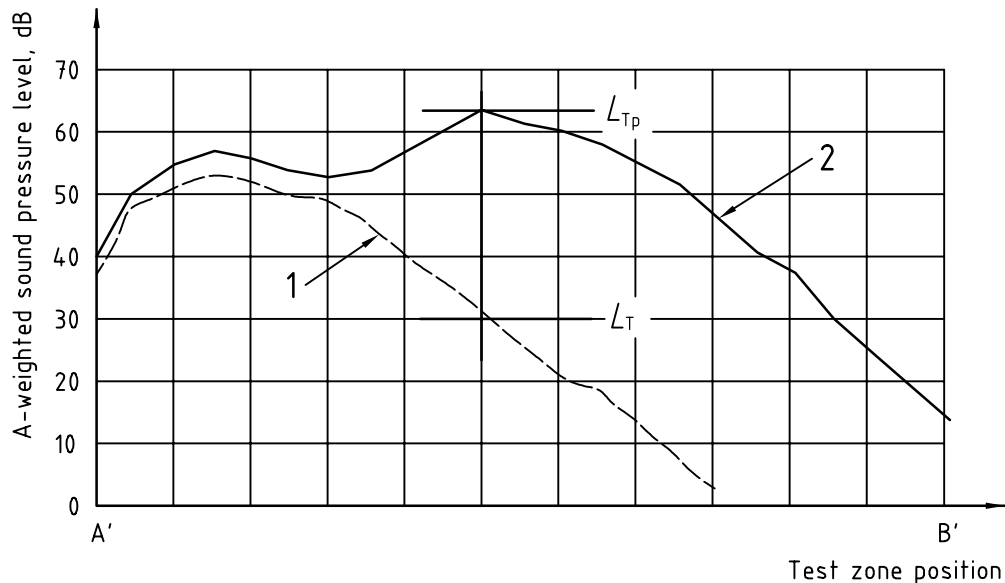

#### Key

- 1 towing vehicle
- 2 towing vehicle and trailer

**Figure B.2 — Time history data for trailer coast-by measurement**

After the alignment of the time histories with respect to  $O'-O'$ , a key parameter in the analysis is the difference between the average time history level for the combination (trailer and towing vehicle) and the towing-vehicle-alone average time history level at the same point. This difference is highlighted by Figure B.2.

If this difference is  $\geq 10$  dB, the levels measured for the towing vehicle and trailer combination are the correct values for the tyre under test; if  $< 10$  dB, then the tyre sound pressure level is calculated by the logarithmic subtraction of the combined and towing vehicle levels as given below. This logarithmic subtraction is performed using the average time history levels noted above and shown in Figure B.2. The reported tyre sound pressure level is the result from the equation:

$$L_{\text{tyre}} = 10 \lg \left[ 10^{(L_{Tp}/10)} - 10^{(L_T/10)} \right] \text{ dB}$$

where

$L_{Tp}$  is the maximum sound pressure level of the test pass (towing vehicle-trailer combination);

$L_T$  is the sound pressure level of the towing vehicle without trailer obtained at the same towing vehicle location as  $L_{Tp}$ .

### B.4.3 Sound pressure level determination procedure

If the average of the maximum sound pressure levels for the towing vehicle and trailer combination for the left and right microphones is higher than the equivalent level for the solo towing vehicle by  $> 10$  dB, the combination sound pressure level is equal to the tyre sound pressure level (calculation illustrated by Table A.3) and steps a), b) and c), as follows, are not necessary. However, if this difference is  $< 10$  dB, proceed as follows, accordingly.

- a) Align the appropriate solo and combination averaged sound pressure level time histories and determine the arithmetic difference in level for each increment in time. Record the sound pressure level difference at the point of the maximum level for the combination. Repeat this entire step for each set of measurement passes.

If the difference recorded is  $> 10$  dB, the combination sound pressure levels are equal to the tyre sound pressure levels.

- b) If the difference computed is  $< 10$  dB and  $> 3$  dB, determine the logarithmic difference between the maximum averaged time history sound pressure level for the towing vehicle and trailer combination, and the averaged time history sound pressure level for the towing vehicle alone, at the moment when the maximum of the combination occurred.
- c) If the difference computed is  $< 3$  dB, the measurement is invalid. The towing vehicle sound pressure level shall then be decreased until this level difference is  $> 3$  dB so that a valid tyre sound pressure level can be computed.

See Tables B.1 and B.2.

### B.5 Test report

The test report shall include the following information:

- a) reference to this International Standard;
- b) meteorological conditions, which shall include the ambient air and surface temperature for each run;
- c) when and how compliance of the test surface with ISO 10844 was checked;
- d) test rim width;
- e) tyre data, including manufacturer, brand name, trade name, size, LI or load capacity, speed symbol, reference pressure, and serial number of the tyre;
- f) test vehicle type and make, vehicle year model and information about any modifications to the vehicle related to sound;
- g) description of test apparatus, including, specifically, the drawbar length and suspension alignment at test loads;
- h) tyre load in kilograms and in percent of the LI for each test tyre;
- i) cold inflation pressure in kilopascals for each test tyre;
- j) test speeds at which the vehicle passed the microphones;
- k) maximum sound pressure levels for each coast-by and each microphone;
- l) maximum sound pressure level in decibels, normalized to the reference speed and corrected for temperature, expressed to at least one decimal place.

Tables B.1 and B.2 present the format of a test report form and of a background data form for tyre-road sound tests. Tables B.3, B.4, B.5, B.6 and B.7 give as examples — respectively — a towing vehicle test record, a combination test record, a check for measurement validity, a check for time history calculation and sound pressure level difference and tyre level calculation records.

**Table B.1 — Test report**

<b>Coast-by testing of tyres with respect to sound emission, in accordance with ISO 13325</b>	
Number of test report: _____	
Tyre make (trade name, brand name, manufacturer): _____	
Manufacturer tyre range trade description(s): _____	
Address(es) of tyre manufacturing plant(s): _____	
Size of tyre: _____ Tyre serial No.: _____	
Tyre load index (LI) and speed symbol: _____ Ref. pressure: _____	
Class of tyre: (mark one box)	<input type="checkbox"/> Passenger car (C1) <input type="checkbox"/> Commercial vehicle (C2) <input type="checkbox"/> Commercial vehicle (C3)
Category of use: _____	
Enclosures to this report: _____	
Reported A-weighted sound pressure level: _____ dB, at reference speed of:	
	<input type="checkbox"/> 70 km/h <input type="checkbox"/> 80 km/h
Comments (if any): _____	
Technical service responsible for carrying out the tests: _____	
Name and address of applicant: _____	
Date of test report: _____ Signature: _____	

**Table B.2 — Background data — Information regarding tyre-road sound tests**

This form belongs to Test Report No.: \_\_\_\_\_ Date of sound testing: \_\_\_\_\_

Test vehicle/trailer (type, make, year model, modifications, draw bar length): \_\_\_\_\_

\_\_\_\_\_

Location of test track: \_\_\_\_\_ Date of track certification: \_\_\_\_\_

Test track certification available at: \_\_\_\_\_

\_\_\_\_\_

Tyre test load in kg, front left: \_\_\_\_\_ front right: \_\_\_\_\_ rear left: \_\_\_\_\_ rear right: \_\_\_\_\_

Same, in % of LI, front left: \_\_\_\_\_ front right: \_\_\_\_\_ rear left: \_\_\_\_\_ rear right: \_\_\_\_\_

Tyre inflation in kPa, front left: \_\_\_\_\_ front right: \_\_\_\_\_ rear left: \_\_\_\_\_ rear right: \_\_\_\_\_

Test rim width: \_\_\_\_\_

Temperature measuring sensor type \_\_\_\_\_ Air: \_\_\_\_\_ ; Test surface: \_\_\_\_\_

**Table B.3 — Example results — Towing vehicle test record**

Run No.	Speed km/h	Air temp. °C	Max. sound pressure level left side dB (A-weighted)	Max. sound pressure level right side dB (A-weighted)	Temp. corrected		Included in mean
					Max. sound pressure level left side	Max. sound pressure level right side	
					dB (A-weighted)	dB (A-weighted)	
1	70,1	25	69,7	70,1	70,0	70,4	×
2	69,6	25	69,6	69,9	69,9	70,2	×
3	69,2	26	69,2	69,9	69,6	70,3	×
4	70,2	26	69,7	70,4	70,1	70,8	×
5	70,6	26	70,1	70,7	70,5	71,1	×
6							
7							
8							
9							
Means		26	69,7	70,2	70,0	70,6	



Table B.4 — Example results — Combination (towing vehicle and trailer) test record

Run No.	Speed km/h	Air temp. °C	Max. sound pressure level left side dB (A-weighted)	Max. sound pressure level right side dB (A-weighted)	Temp. corrected		Included in mean
					Max. sound pressure level left side dB (A-weighted)	Max. sound pressure level right side dB (A-weighted)	
1	70,6	23	72,9	73,8	73,1	74,0	×
2	70,3	23	73,1	73,8	73,3	74,0	×
3	69,2	23	72,5	73,1	72,7	73,3	×
4	70,1	23	72,0	73,5	72,2	73,7	
5	69,5	24	72,7	73,4	72,9	73,6	×
6	70,1	24	73,0	73,6	73,2	73,8	×
7							
8							
9							
Means			72,8	73,5	73,0	73,7	

Table B.5 — Example results — Check for measurement validity

	Avg. of max. sound pressure level for towing vehicle dB (A-weighted)	Avg. of max. sound pressure level for combination dB (A-weighted)	Arithmetic difference in level dB (A-weighted)
Left microphone	70,0	73,0	3,0
Right microphone	70,6	73,7	3,1
Average	70,3	73,3	3,0

Table B.6 — Example results — Check for time history calculation

	Max. averaged time history sound pressure level for combination dB (A-weighted)	Avg. time history sound pressure level for towing vehicle at same point relative to O'-O' dB (A-weighted)	Arithmetic difference in level dB (A-weighted)
Left microphone	73,0	66,0	7,0
Right microphone	73,7	66,4	7,3
Average	73,3	66,2	7,2

Table B.7 — Sound pressure level difference and tyre sound pressure level calculation

	<b>Max. averaged time history sound pressure level for combination</b>	<b>Avg. time history sound pressure level for towing vehicle at same point relative to O'–O'</b>	<b>Logarithmic difference in level</b> (see Equation in B.4.2)
	dB (A-weighted)	dB (A-weighted)	dB (A-weighted)
Left microphone	73,0	66,0	72,0
Right microphone	73,7	66,4	72,8
Average	73,3	66,2	72,4
Tyre sound pressure level			72,8

## Bibliography

- [1] ISO 3833, *Road vehicles — Types — Terms and definitions*
- [2] ISO 3877-1, *Tyres, valves and tubes — List of equivalent terms — Part 1: Tyres*
- [3] ISO 4209-1, *Truck and bus tyres and rims (metric series) — Part 1: Tyres*

