

INTERNATIONAL STANDARD

ISO
13271

First edition
2012-06-15

Stationary source emissions — Determination of PM₁₀/PM_{2,5} mass concentration in flue gas — Measurement at higher concentrations by use of virtual impactors

Émissions de sources fixes — Détermination de la concentration en masse de PM₁₀/PM_{2,5} dans les effluents gazeux — Mesurage à des hautes concentrations à l'aide des impacteurs virtuels



Reference number
ISO 13271:2012(E)

© ISO 2012

ISO 13271:2012(E)



COPYRIGHT PROTECTED DOCUMENT

© ISO 2012

All rights reserved. Unless otherwise specified, no part of this publication may be reproduced or utilized in any form or by any means, electronic or mechanical, including photocopying and microfilm, without permission in writing from either ISO at the address below or ISO's member body in the country of the requester.

ISO copyright office
Case postale 56 • CH-1211 Geneva 20
Tel. + 41 22 749 01 11
Fax + 41 22 749 09 47
E-mail copyright@iso.org
Web www.iso.org

Published in Switzerland

Contents

Page

Foreword	iv
Introduction	v
1 Scope	1
2 Normative references	1
3 Terms and definitions	1
4 Symbols and abbreviated terms	4
4.1 Symbols	4
4.2 Abbreviated terms	5
5 Principle	6
5.1 General	6
5.2 Theory of virtual impactor	6
6 Specification of the two-stage virtual impactor	8
6.1 General	8
6.2 Separation curves	8
6.3 Verification of the separation curves	9
6.4 Operating conditions	9
7 Sampling train	12
7.1 Measuring setup	12
7.2 Equipment and working materials	13
8 Preparation, measurement procedure and post-treatment	15
8.1 General	15
8.2 Pre-treatment	15
8.3 Measurement procedure	16
8.4 Weighing procedure	17
8.5 Post-sampling treatment of weighed parts	18
9 Calculation of the results	18
10 Performance characteristics	19
10.1 Virtual impactor load	19
10.2 Detection limit	19
10.3 Measurement uncertainty	19
10.4 Particle losses	19
11 Test report	20
Annex A (informative) Physical property estimation for the calculation of sample volume flow rate	21
Annex B (informative) Errors by deviations from isokinetic sampling	25
Annex C (informative) Example of a two-stage virtual impactor	27
Annex D (informative) Influence of variations in the flue gas temperature and flue gas composition on the Reynolds number	31
Annex E (informative) Entry nozzle	34
Annex F (informative) Equipment list	35
Annex G (normative) Determination of a representative sampling point	37
Annex H (informative) Generation of standard aerosol for virtual impactor calibration	39
Bibliography	40

ISO 13271:2012(E)

Foreword

ISO (the International Organization for Standardization) is a worldwide federation of national standards bodies (ISO member bodies). The work of preparing International Standards is normally carried out through ISO technical committees. Each member body interested in a subject for which a technical committee has been established has the right to be represented on that committee. International organizations, governmental and non-governmental, in liaison with ISO, also take part in the work. ISO collaborates closely with the International Electrotechnical Commission (IEC) on all matters of electrotechnical standardization.

International Standards are drafted in accordance with the rules given in the ISO/IEC Directives, Part 2.

The main task of technical committees is to prepare International Standards. Draft International Standards adopted by the technical committees are circulated to the member bodies for voting. Publication as an International Standard requires approval by at least 75 % of the member bodies casting a vote.

Attention is drawn to the possibility that some of the elements of this document may be the subject of patent rights. ISO shall not be held responsible for identifying any or all such patent rights.

ISO 13271 was prepared by Technical Committee ISO/TC 146, *Air quality*, Subcommittee SC 1, *Stationary source emissions*.

Introduction

In order to quantify the amount of PM₁₀ and PM_{2,5} particles in stationary source emissions or to identify the contribution sources of PM₁₀ and PM_{2,5} in ambient air, it is necessary to measure fine particulate matter in the flue gas of industrial sources.

This International Standard describes a measurement method for determination of mass concentrations of PM₁₀ and PM_{2,5} emissions, which realizes the same separation curves as those specified in ISO 7708^[1] for PM₁₀ and PM_{2,5} in ambient air. The method is based on the principle of gas stream separation using two-stage virtual impactors. This is applicable to higher dust concentrations than the concentrations used for cascade impactors with impaction plates.

The measurement method allows the simultaneous determination of concentrations of PM₁₀ and PM_{2,5} emissions. The method is designed for in-stack measurements at stationary emission sources with possible reactive gases and/or high water vapour.

The contribution of stationary source emissions to PM₁₀ and PM_{2,5} concentrations in ambient air is classified as primary and secondary. Those emissions that exist as particulate matter within the stack gas and that are emitted directly to air can be considered "primary". Secondary particulate consists of those emissions that form in ambient air due to atmospheric chemical reactions. The measurement technique in this International Standard does not measure the contribution of stack emissions to the formation of secondary particulate matter in ambient air.

Stationary source emissions — Determination of PM₁₀/PM_{2,5} mass concentration in flue gas — Measurement at higher concentrations by use of virtual impactors

1 Scope

This International Standard specifies a standard reference method for the determination of PM₁₀ and PM_{2,5} mass concentrations at stationary emission sources by use of two-stage virtual impactors. The measurement method is especially suitable for in-stack measurements of particle mass concentrations in flue gas. The method can also be used for flue gas which contains highly reactive compounds (e.g. sulfur, chlorine, nitric acid) at high temperature or in the presence of high humidity.

The International Standard is applicable to higher dust concentrations. Coarse particles are separated into the nozzles with negligible rebound and entrainment phenomena of collected coarse particulates. For the same reason, the artefacts due to high concentrations in gases or emissions are quite limited.

This International Standard is not applicable to the determination of the total mass concentration of dust.

2 Normative references

The following referenced documents are indispensable for the application of this document. For dated references, only the edition cited applies. For undated references, the latest edition of the referenced document (including any amendments) applies.

ISO 12141, *Stationary source emissions — Determination of mass concentration of particulate matter (dust) at low concentrations — Manual gravimetric method*

3 Terms and definitions

For the purposes of this document, the following terms and definitions apply.

3.1

aerodynamic diameter

diameter of a sphere of density 1 g/cm³ with the same terminal velocity due to gravitational force in calm air as the particle under prevailing conditions of temperature, pressure, and relative humidity

NOTE Adapted from ISO 7708:1995,^[1] 2.2.

3.2

backup filter

plane filter used for collection of the PM_{2,5} particle fraction

[ISO 23210:2009,^[7] 3.2.3]

3.3

collection filter

plane filter used for coarse particle collection

3.4

Cunningham factor

correction factor taking into account the change in the interaction between particles and the gas phase

[ISO 23210:2009,^[7] 3.1.7]

NOTE See A.2.

ISO 13271:2012(E)

3.5 cut-off diameter

aerodynamic diameter where the separation efficiency of the impactor stage is 50 %

[ISO 23210:2009,^[7] 3.1.2]

NOTE Particle separation with real impactors is not ideal and exhibits separation curves similar to the example shown in Figure 1.

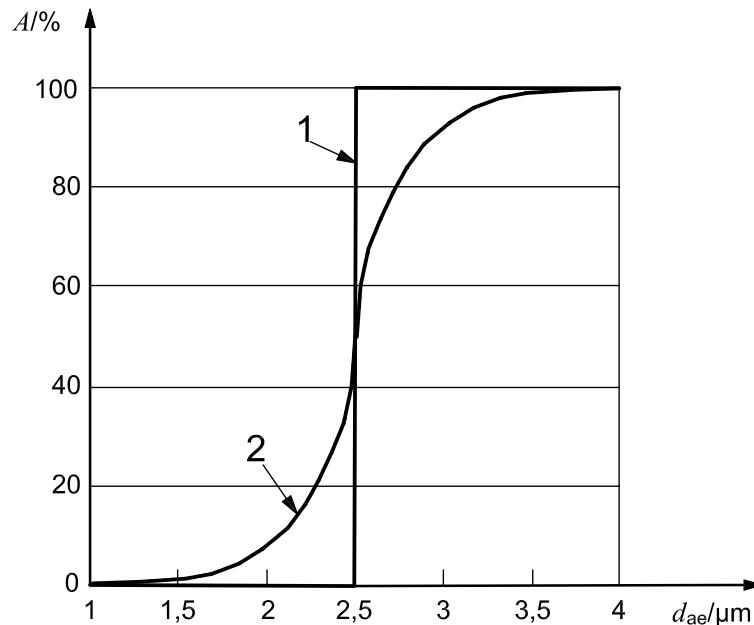

Key

A	separation efficiency	1	ideal
d_{ae}	aerodynamic diameter	2	real

Figure 1 — Separation efficiency A of an impactor as a function of aerodynamic diameter d_{ae} (adapted from ISO 23210:2009,^[7] Figure 2)

3.6 filter holder

substrate holder designed to hold a filter and for which only the filter deposit is analysed (weighed)

[ISO 15767:2009,^[4] 2.4]

3.7 measurement plane sampling plane

plane normal to the centreline of the duct at the sampling position

[ISO 23210:2009,^[7] 3.3.3]

3.8 measurement section

region of the waste gas duct which includes the measurement plane(s) and the inlet and outlet sections

[ISO 23210:2009,^[7] 3.3.2]

3.9

measurement site

sampling site

place on the flue gas duct in the area of the measurement plane(s) consisting of structures and technical equipment

NOTE The measurement site consists, for example, of working platforms, measurement ports and energy supply.

[ISO 23210:2009,^[7] 3.3.1]

3.10

PM_{2,5}

particles which pass through size-selective nozzles with 50 % efficiency cut-off at 2,5 µm aerodynamic diameter

NOTE PM_{2,5} corresponds to the “high risk respirable convention” as defined in ISO 7708:1995,^[1] 7.1.

[ISO 23210:2009,^[7] 3.1.4]

3.11

PM₁₀

particles which pass through size-selective nozzles with 50 % efficiency cut-off at 10 µm aerodynamic diameter

NOTE PM₁₀ corresponds to the “thoracic convention” as defined in ISO 7708:1995,^[1] Clause 6.

[ISO 23210:2009,^[7] 3.1.3]

3.12

Reynolds number

Re

$$Re = \frac{\rho v l}{\eta}$$

where

ρ is the mass density;

v is the gas velocity in the particle acceleration nozzle;

l is the length;

η is the dynamic viscosity.

NOTE 1 Adapted from ISO 80000-11:2008,^[8] 11-4.1.

NOTE 2 “Dimensionless” parameter (parameter of dimension 1) describing flow conditions.

3.13

Stokes's number

St

$$St = \frac{\rho_{0,P} d_{ae}^2 C_m v}{9\eta D_0}$$

where

ISO 13271:2012(E)

$\rho_{0,P}$ is the particle density (1 g/cm³);

d_{ae} is the aerodynamic diameter (m);

C_m is the Cunningham factor;

v is the gas velocity in the particle acceleration nozzle (m/s);

η is the dynamic viscosity of the gas (Pa s);

D_0 is the particle acceleration nozzle diameter (m).

NOTE 1 Adapted from ISO 23210:2009,^[7] B.2.

NOTE 2 An instrument-specific “dimensionless” parameter (parameter of dimension 1) describing a measure of the inertial movement of a particle in gas stream near an obstacle.

3.14

particle acceleration nozzle

acceleration nozzle used for accelerating particle-laden gas before separation takes place in the particle collection nozzle

3.15

particle collection nozzle

collection nozzle used for coarse-particle separation

4 Symbols and abbreviated terms

4.1 Symbols

A	separation efficiency
C_m	Cunningham factor
D_0	particle acceleration nozzle diameter
D_1	particle collection nozzle diameter
d_{ae}	aerodynamic diameter
d_{entry}	internal diameter of the entry nozzle
d_{50}	cut-off diameter
i	series element number, $i = 1, 2, 3, \dots, m$, or a subscript to identify the particle fraction ($i = 2, 5 \mu\text{m}, 10 \mu\text{m}$)
j	series element number, $j = 1, 2, 3, \dots, n$
l_0	impactor nozzle length
m_{BF}	particle mass on the backup filter
m_{CF2}	particle mass on the collection filter of the second separation stage
N	number of impactor nozzles
n	number of measurement pairs
p_{amb}	ambient pressure at the measurement site
p_n	standard pressure

p_{st}	difference between the static pressure in the measurement cross-section and the atmospheric pressure at the measurement site
q_V	volume flow rate at operating conditions
q_{Vn}	volume flow rate under standard conditions and for dry gas
q_{V0}	volume flow rates per nozzle at operating conditions for total flow
q_{V1}	volume flow rates per nozzle at operating conditions for minor flow
q_{V2}	volume flow rates per nozzle at operating conditions for major flow
Re	Reynolds number
St_{50}	Stokes's number in relation to the cut-off diameter d_{50}
s	distance between the end of the particle acceleration nozzle and the top of the particle collection nozzle
T	gas temperature
T_n	standard temperature
$u(\gamma)$	standard uncertainty of paired measurements
v	gas velocity at particle acceleration nozzle
v_{fg}	flue gas velocity
V_n	sample volume under standard conditions and for dry gas
$\gamma_{n,H_2O,v}$	mass concentration of water vapour under standard conditions and with dry gas
$\gamma(PM_{2,5})$	concentration of $PM_{2,5}$
$\gamma(PM_{10})$	concentration of PM_{10}
$\gamma_{1,i}$	i th concentration value of the first measuring system
$\gamma_{2,i}$	i th concentration value of the second measuring system
η	dynamic viscosity of the gas
$\rho_{n,H_2O,v}$	density of water vapour under standard conditions
$\rho_{0,P}$	particle density (1 g/cm ³)
ξ	minor flow ratio at impactor stage

4.2 Abbreviated terms

BF	backup filter
CF1	collection filter of the first separation stage
CF2	collection filter of the second separation stage

ISO 13271:2012(E)

5 Principle

5.1 General

In particle measurements, the following three relevant physical characteristics can be distinguished:

- mass concentration (e.g. total dust, PM₁₀, PM_{2,5}) and distribution of mass fractions;
- particle number concentration and particle size distribution by number;
- morphology of particles (e.g. shape, colour, optical properties).

The PM₁₀ and PM_{2,5} mass concentrations are determined by size-selective separation of gas-borne particles by use of the different inertia of particles.

This International Standard specifies a measurement method for the determination of PM₁₀ and PM_{2,5} for higher mass concentrations using two-stage virtual impactors based on the principle of gas stream separation without impaction plates, and with negligible rebound and entrainment phenomena of collected coarse particulates.

5.2 Theory of virtual impactor

Size separation by a virtual impactor stage is based on the inertia of accelerated and decelerated particles in a gas flow. The principle of operation of a separation stage and the major parameters governing the performance are shown in Figure 2.

The separation stage consists in its basic configuration, of coaxially oriented particle acceleration and collection nozzles whose diameters are designated D_0 and D_1 , respectively (see Figure 2). The particle-laden gas enters the nozzles and accelerates depending on D_0 and the total flow rate, and part of the stream is directed to the particle collection nozzles. Flow rate through particle collection nozzles, which is called minor flow rate, is approximately 10 % of the total flow rate. The major fraction or major flow is redirected and bypasses the particle collection nozzles. Consequently, particles above a certain aerodynamic size (cut-off size) are entrained in the minor flow received by the particle collection nozzles and are collected on a filter. Fine particles smaller than this cut-off size stay in the major stream and are directed into the next separation stage.

The performance of a separation stage is characterized by a separation efficiency curve. Due to the specific characteristics of this separation process, there is always a residue of particles larger than the minor flow cut-off size and particles smaller than major flow cut-off.

A separation stage is specified with the cut-off diameter, d_{50} . For particles with this aerodynamic diameter, the separation efficiency of the impactor stage is 50 %. Formula (1) is used to calculate the cut-off diameter, d_{50} :

$$d_{50} = \sqrt{\frac{9\pi St_{50}\eta D_0^3}{4\rho_{0,P}C_m q_{V0}}} \quad (1)$$

where

- St_{50} is the Stokes's number in relation to the cut-off diameter, d_{50} , an instrument-specific quantity;
- η is the dynamic viscosity of the gas;
- q_{V0} is the total volume flow rate per nozzle under operating conditions;
- D_0 is the particle acceleration nozzle diameter;
- $\rho_{0,P}$ is the particle density (1 g/cm³) (the inertial cut-off diameter is given in terms of an aerodynamic diameter);
- C_m is the Cunningham factor.

The following conditions apply to the design and to the application of Formula (1):

- a) for the design of the separation stages, the value of the St_{50} shall be chosen (Reference [10]) to be

$$0,4 \leq St_{50} \leq 0,5$$

- b) the ratio of distance between the end of the particle acceleration nozzle and the top of the particle collection nozzle, s , to the particle acceleration nozzle diameter, D_0 , shall be

$$0,8 < s/D_0 < 2$$

- c) the ratio of particle acceleration nozzle length, l_0 , to particle acceleration nozzle diameter, D_0 , shall be

$$l_0/D_0 < 2,5$$

- d) the ratio of particle collection nozzle diameter, D_1 , to particle acceleration nozzle diameter, D_0 , shall be

$$D_1/D_0 \approx 1,33$$

- e) Reynolds number, Re , of the gas flow in the particle acceleration nozzle shall be in the region of laminar flow

$$100 < Re < 3\,000$$

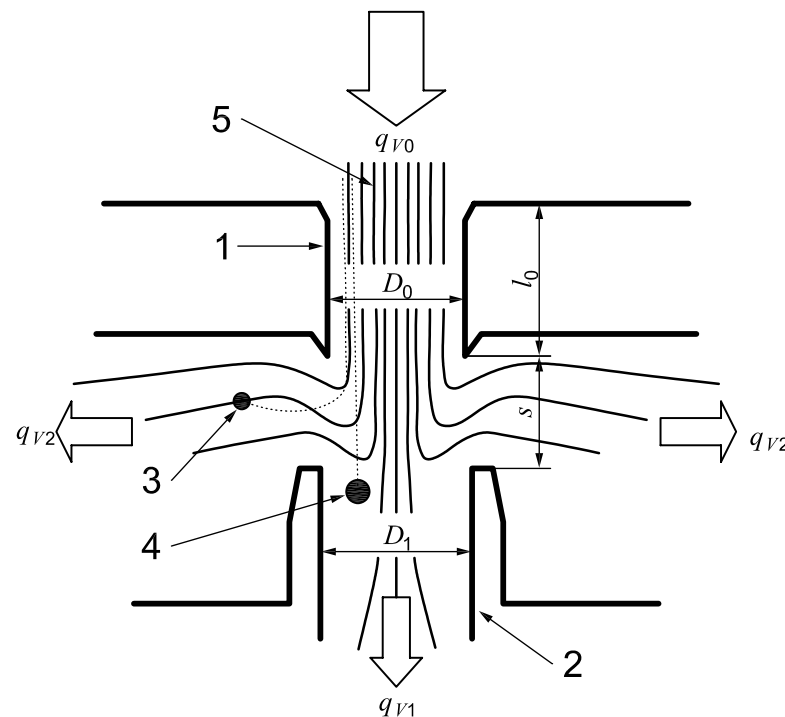

Key

1	particle acceleration nozzle	D_0	particle acceleration nozzle diameter
2	particle collection nozzle	D_1	particle collection nozzle diameter
3	trajectory of fine particles to be measured	l_0	impactor nozzle length
4	trajectory of coarse particles	s	distance between the end of the particle acceleration nozzle and the top of the particle collection nozzle
5	stream lines	q_{v0}	total flow rate
		q_{v1}	minor flow rate
		q_{v2}	major flow rate

Figure 2 — Principle of the virtual impactor

ISO 13271:2012(E)

6 Specification of the two-stage virtual impactor

6.1 General

This International Standard specifies a two-stage virtual impactor for the determination of PM_{10} and $PM_{2,5}$ mass concentrations (Reference [10]).

A two-stage virtual impactor consists of two separation stages. The first stage separates the largest particles using a particle collection nozzle. The coarse particles are collected on a plane filter. Smaller particles reach the following stage.

The two-stage virtual impactor divides the particles into the following three fractions:

- particles with aerodynamic diameters greater than $10\ \mu\text{m}$ (first separation stage);
- particles with aerodynamic diameters between $10\ \mu\text{m}$ and $2,5\ \mu\text{m}$ (second separation stage);
- particles with aerodynamic diameters smaller than $2,5\ \mu\text{m}$ (backup filter).

The $PM_{2,5}$ mass corresponds to fraction c) and the PM_{10} mass corresponds to the sum of fractions b) and c). The fraction with aerodynamic diameters greater than $10\ \mu\text{m}$ is not used for the PM_{10} and $PM_{2,5}$ data evaluation.

6.2 Separation curves

The separation curves of PM_{10} and $PM_{2,5}$ emission measurements shall correspond to the separation curves for PM_{10} and $PM_{2,5}$ ambient air quality measurements specified in ISO 7708^[1] for the corresponding particle diameters (see Figure 3). The virtual impactor separation stages for PM_{10} and $PM_{2,5}$ shall be designed in such a way that the separation curves of PM_{10} and $PM_{2,5}$ stages meet the requirements of the separation efficiencies specified in Table 1. The permissible deviations specified in Table 1 are absolute percentages relating to the separation efficiencies specified in ISO 7708.^[1]

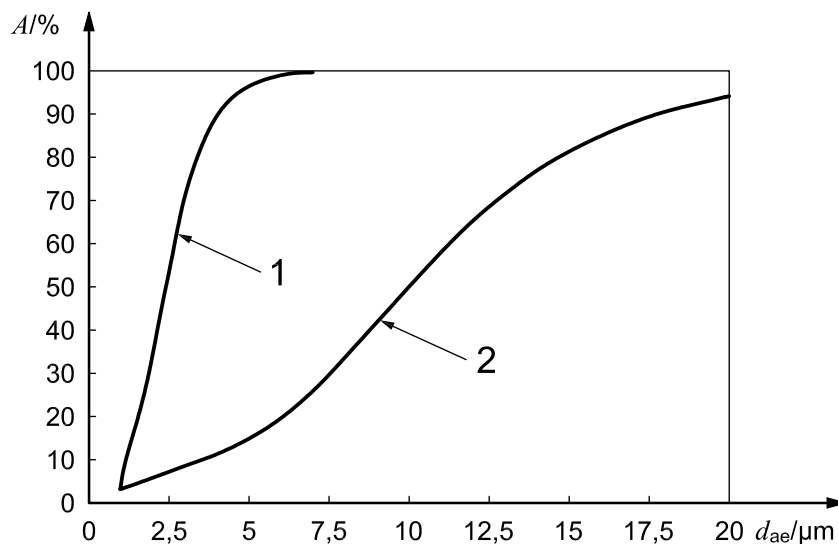

Key

A	separation efficiency	1	high-risk respirable convention ($PM_{2,5}$)
d_{ae}	aerodynamic diameter	2	thoracic convention (PM_{10})

Figure 3 — Separation curves of PM_{10} and $PM_{2,5}$ specified in ISO 7708^[1]

Table 1 — Separation efficiency for the virtual impactor stage with permissible deviation

Particle diameter	PM ₁₀ stage	PM _{2,5} stage
>3 µm	Permissible deviation of ±10 %	
<3 µm	Permissible deviation of ±15 %	
>1,5 µm		Permissible deviation of ±10 %
<1,5 µm		Permissible deviation of ±20 %

6.3 Verification of the separation curves

The separation characteristics of a virtual impactor design shall be evaluated for each stage by the manufacturer in order to prove that the performance criteria specified in 6.2 are met. The validation shall be carried out by a testing laboratory operating an internationally recognized quality management system.

NOTE Requirements for testing laboratories are specified, for example, in ISO/IEC 17025.^[5]

The separation efficiency of the virtual impactor shall be determined by performing experiments for each stage with a mostly monodisperse aerosol, e.g. oleic acid, poly(alpha-olefin) or dioctyl phthalate (References [10]–[12]), polystyrene latex (Reference [13]) or glass spheres (Reference [14]) of different diameters in the range of 1 µm to 20 µm. Aerosol generation shall be performed using mechanical or electrical power-assisted methods (see Annex H).

For the PM_{2,5} stage, tests with at least six different particle diameters between 1 µm and 10 µm shall be performed. For the PM₁₀ stage, tests with at least six different particle diameters between 2 µm and 20 µm shall be performed. In both cases, the particle diameters shall be distributed over the full range about the cut-off diameter. One of these particle diameters shall be as close as possible to the cut-off diameter.

The values of the Stokes's number St_{50} for the 2,5 µm and 10 µm stages of the impactor under examination in relation to the cut-off diameter shall be calculated on the basis of the experimental data and Formula (1).

The separation efficiencies and the values of the Stokes's number determined shall be reported.

6.4 Operating conditions

6.4.1 General considerations

To meet the given cut-off limits of 10 µm and 2,5 µm particle diameters, the impactor shall be operated with a constant sample volume flow rate, to be previously determined. For a given virtual impactor design, the volume flow rate depends only on the flue gas conditions and is calculated as specified in 6.4.2 and 6.4.3.

6.4.2 Variables to calculate the sample volume flow rate of the impactor

The following variables are required for the calculation of sample volume flow rate:

- gas composition;
- gas conditions;
- gas velocity.

ISO 13271:2012(E)

6.4.3 Sample and suction volume flow rate

The required total volume flow rate of each stage, q_{Vi} , under operating conditions, is calculated by Formula (2):

$$q_{Vi} = \frac{9\pi D_{0,i} St_{50,i} \eta N_i}{4d_{50,i}^2 C_{m,i} \rho_{0,P}} \quad (2)$$

where

i identifies the particle fraction ($i = 2,5 \mu\text{m}, 10 \mu\text{m}$);

$D_{0,i}$ is the impactor nozzle diameter (constant);

St_{50} is the Stokes's number (constant);

η is the viscosity of the gas;

N_i is the number of impactor nozzles (constant);

$d_{50,i}$ is the cut-off particle diameter (50 % value of separation at the nozzle; constant);

$C_{m,i}$ is the Cunningham factor of particle fraction i ;

$\rho_{0,P}$ is the particle density (1 g/cm³).

The volume flow rates of both stages are calculated separately. The sample volume flow rate, q_V , in a two-stage virtual impactor has the following relationship:

$$q_V = q_{V,10 \mu\text{m}} \quad (3)$$

The volume flow rates of the suction lines of a two-stage virtual impactor are illustrated in Figure 4 and can be simplified as in Formulae (4)–(6):

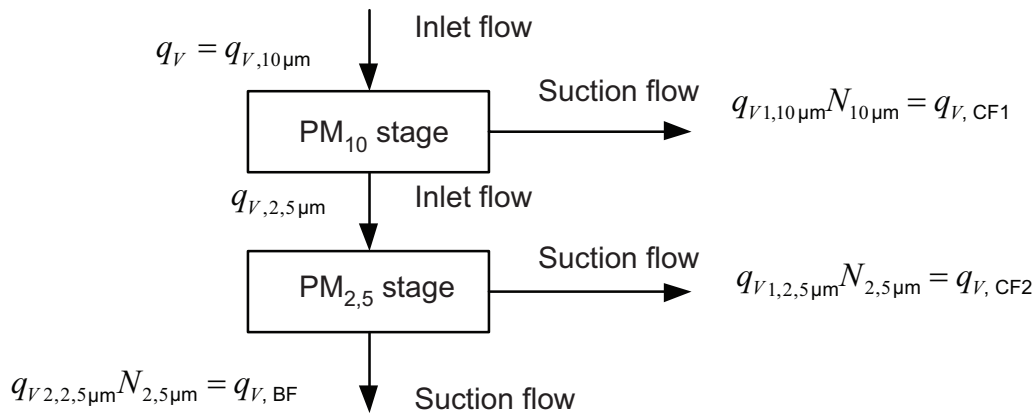

Figure 4 — Schematic of volume flow rates in two-stage virtual impactor

$$q_{V,CF1} = \xi_{10 \mu\text{m}} q_{V,10 \mu\text{m}} = q_{V,10 \mu\text{m}} - q_{V,2,5 \mu\text{m}} \quad (4)$$

$$q_{V,CF2} = \xi_{2,5 \mu\text{m}} q_{V,2,5 \mu\text{m}} \quad (5)$$

$$q_{V,BF} = (1 - \xi_{2,5 \mu\text{m}}) q_{V,2,5 \mu\text{m}} \quad (6)$$

where

q_V is the sample volume flow rate;

$q_{V,2,5 \mu m}$	is the inlet volume flow rate of PM _{2,5} stage;
$q_{V,CF1}$	is the suction volume flow rate of PM ₁₀ stage;
$q_{V,CF2}$	is the suction volume flow rate of PM _{2,5} stage;
$q_{V,BF}$	is the suction volume flow rate of the backup filter;
$q_{V1,10 \mu m}$	is the minor flow through nozzle of PM ₁₀ stage;
$N_{10 \mu m}$	is the number of impactor nozzles on PM ₁₀ stage;
$q_{V1,2,5 \mu m}$	is the minor flow rate through nozzle of PM _{2,5} stage;
$N_{2,5 \mu m}$	is the number of impactor nozzles on PM _{2,5} stage;
$q_{V2,2,5 \mu m}$	is the major flow rate through nozzle of PM _{2,5} stage;
$\xi_{10 \mu m}$	is the minor flow ratio at PM ₁₀ stage;
$\xi_{2,5 \mu m}$	is the minor flow ratio at PM _{2,5} stage.

Approximately 10 % of the total suction flow is recommended to be that from each stage. Therefore $\xi_{10 \mu m} \approx 0,1$ and $\xi_{2,5 \mu m} \approx 0,1$.

The sample volume flow rate under standard conditions and for dry gas, q_{Vn} shall be calculated using Formula (7):

$$q_{Vn} = q_V \frac{T_n(p_{amb} + p_{st})}{p_n T \left[1 + \left(\gamma_{n,H_2O,v} / \rho_{n,H_2O,v} \right) \right]} \quad (7)$$

where

T	is the gas temperature under operating conditions;
T_n	is the standard temperature; $T_n = 273,15$ K;
p_{amb}	is the ambient pressure at the measurement site;
p_n	is the standard pressure; $p_n = 1\,013,25$ hPa;
p_{st}	is the difference between the static pressure in the measurement cross-section and the atmospheric pressure at the measurement site (barometric pressure);
$\gamma_{n,H_2O,v}$	is the mass concentration of water vapour under standard conditions and with dry gas;
$\rho_{n,H_2O,v}$	is the density of water vapour under standard conditions; $\rho_{n,H_2O,v} = 0,803\,8$ kg/m ³ .

For the calculation of the volume flow rates according to Formula (2), the following parameters shall be calculated:

- the dynamic viscosity, $\eta(T)$, of the gas mixture under operating conditions;
- the Cunningham factor, $C_{m,i}$, of particle fraction i .

Formulae to calculate these parameters are given in Annex A.

ISO 13271:2012(E)

6.4.4 Entry nozzle diameter

The diameter, d_{entry} , of the entry nozzle is calculated to satisfy Formula (8) from the required sample volume flow rate, q_V , and the flue gas velocity, v_{fg} , at the sampling point:

$$0,9 \leq \frac{4q_V}{\pi d_{\text{entry}}^2} / v_{\text{fg}} \leq 1,3 \quad (8)$$

Over-isokinetic sampling is preferred, since the error in the collection efficiency is smaller than for sampling below isokinetic conditions (see Annex B)

6.4.5 Applicable operating conditions

The measurement method specified in this International Standard is applicable for the operating conditions given in Table 2. Typical gas compositions range from air to flue gases with up to 30 % volume fraction carbon dioxide.

Table 2 — Typical operating conditions of the measurement method

Parameter	Mean value	Minimum value	Maximum value
Dust concentration, mg/m ³	40	1	200
Temperature, °C	135	20	250
Pressure, hPa	1 000	850	1 100
Water vapour content, g/m ³ ^a	30	0	100

^a The dew-point shall be below the flue gas temperature.

If these operating conditions are not met, especially at higher water vapour content or higher flue gas temperatures, measurements shall be taken in such a way that the Reynolds number of each separation stage is between 100 and 3 000. In this case, the similarity condition according to the theory of Marple and Liu (see Reference [15]) is still fulfilled. The Reynolds number of the flow in each stage can be determined according to Annex D.

6.4.6 Components

The two-stage virtual impactor shall have the following components:

- inlet cone in accordance with the requirements of ISO 12141, if needed;
- particle acceleration nozzles at PM₁₀ separation stage;
- particle collection nozzles, filter and filter holder for the particle fraction greater than 10 µm;
- particle acceleration nozzles at PM_{2,5} separation stage;
- particle collection nozzles, filter and filter holder for the particle fraction between 10 µm and 2,5 µm;
- backup filter and filter holder for the particle fraction smaller than 2,5 µm.

An example of a cascade virtual impactor is given in Annex C.

7 Sampling train

7.1 Measuring setup

Figure 5 shows an example of the general measurement setup. Gas-volume-measuring devices need to be applicable under the pressure indicated by the pressure meters.

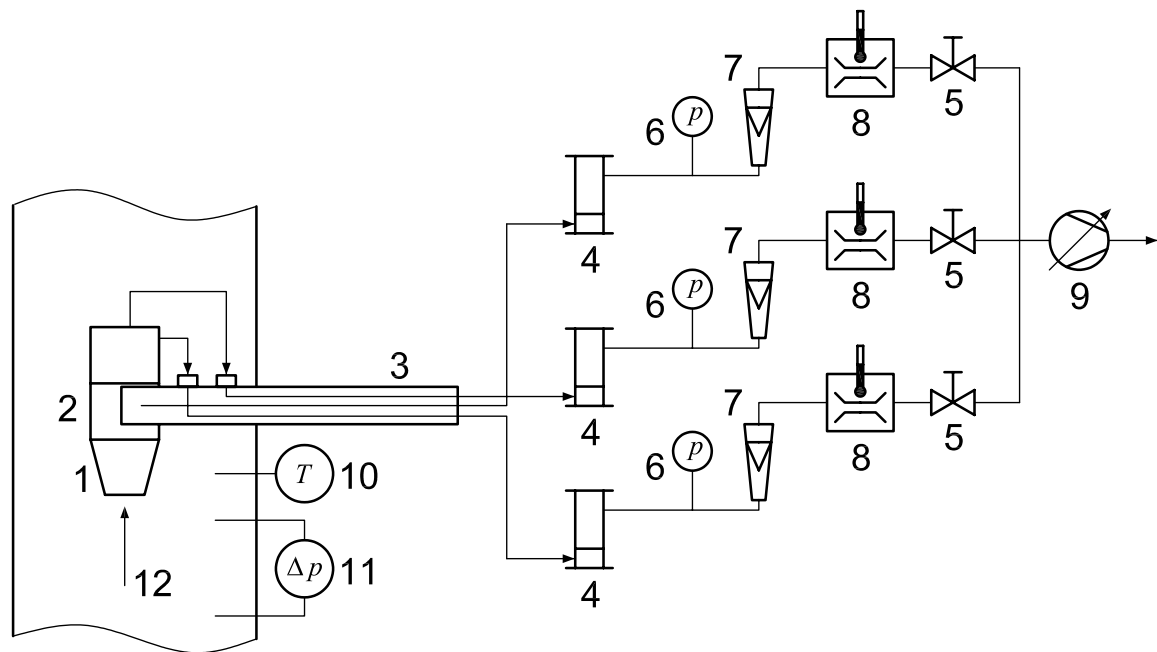

Key

- | | | | |
|---|----------------------------|----|--|
| 1 | entry nozzle | 7 | flowmeter |
| 2 | two-stage virtual impactor | 8 | gas-volume-measuring device with thermometer |
| 3 | support tube | 9 | suction device |
| 4 | cooling and drying column | 10 | temperature-measuring device |
| 5 | valve | 11 | Pitot tube with differential pressure meter |
| 6 | pressure meter | 12 | gas flow in the flue gas |

Figure 5 — Example of the design of the sampling system

Measurements using three suction devices are acceptable. In this case, the requirements for components downstream of the impactor shall be in accordance with ISO 12141.

Measurements with an in-stack sampling system with a straight entry nozzle are recommended. In-stack measurements with a goose-neck nozzle in front of the impactor can cause higher particle losses in the probe. Furthermore, out-stack measurements require an exact external thermal control of the impactor to meet the exact cut-off diameter. If in-stack measurements with a goose-neck nozzle in front of the impactor are performed, validation experiments shall be carried out, including the quantification of losses related to coarse and fine particles. These measurement setups shall only be used if losses of particles in the sampling train are below 10 % of the total mass of fine particles collected on the collection and backup filters.

7.2 Equipment and working materials

7.2.1 Sampling equipment

The virtual impactor shall be of corrosion-proof material, e.g. titanium or stainless steel. The entry nozzle shall be of the same material as the virtual impactor. A set of nozzles with various effective diameters between at least 3 mm and 18 mm shall be available (see Annex C and E).

7.2.2 Equipment for extraction and adjustment of the sample volume flow rate

The following equipment for extraction and adjustment of the sample volume flow rate shall be provided:

- gas-carrying flexible tubes of sufficient length to connect the parts of the sampling train downstream of the suction tube;

ISO 13271:2012(E)

- support parts with stable tube or rod for virtual impactor setting;
- special heater for heating the complete impactor, if needed;
- drying tower with a desiccant for drying the sample gas;
- suction device (e.g. a corrosion-proof gastight pump with a protective filter and minimum delivery output of 2 m³/h at 0,04 MPa at the extraction side, preferably with automatic flow control);
- one gas volume meter of nominal capacity of 3 m³/h and two gas volume meter of nominal capacity of 1 m³/h;
- gas flowmeter;
- temperature-measuring device for the sample gas flow;
- pressure-measuring device for static pressure in the duct or static differential pressure between the duct and the atmosphere at the measurement site;
- time-measuring device;
- pressure-measuring device for measuring the atmospheric pressure at the measurement site;
- shut-off and control valves or other device for adjustment of the sample gas flow.

Depending on the gas properties, a condensate trap can be necessary to avoid any back-flow of condensate to the measuring filter. If necessary, heating or cooling of the condensate trap shall be provided.

NOTE Requirements concerning the equipment for extraction and adjustment of the sample volume flow rate are specified, for example, in ISO 12141.

7.2.3 Equipment for measuring the gas velocity, gas composition and reference quantities

The following equipment for measuring the gas velocity and the gas composition shall be provided:

- gas-velocity-measuring device, e.g. Pitot tube with a micromanometer;
- gas analysers for determining CO₂ and O₂ in the flue gas;
- temperature-measuring device
- device for measuring water vapour content.

NOTE Requirements concerning the equipment for measuring the gas velocity and the gas composition are specified, for example, in ISO 12141.

7.2.4 Equipment for pre-treatment and post-treatment in the laboratory

The following equipment for pre-treatment and post-treatment of the filter samples in the laboratory shall be provided:

- microbalance, e.g. measuring range: 60 g, resolution: 0,1 mg;
- drying chamber;
- transport container for the sampling filters.

7.2.5 Working materials

The following working materials shall be provided:

- plane filter of quartz-fibre material;
- drying agent, e.g. silica gel with colour indicator.

The collection filter and the backup filter shall consist of quartz-fibre plane filters, which shall comply with the following minimum requirements.

- a) The filter efficiency shall be better than 99,5 % on a test aerosol with a mean particle diameter of 0,3 μm at the maximum flow rate anticipated or 99,9 % on a test aerosol of 0,6 μm mean diameter. This efficiency shall be attested by the filter supplier.
- b) The filter material shall not react with or adsorb gaseous compounds contained in the gas to be sampled and shall be thermally stable, taking into account the maximum temperature anticipated (conditioning, sampling, etc.).

8 Preparation, measurement procedure and post-treatment

8.1 General

Measurement ports should be consistent with the requirements of International Standards or national standards with respect to the location, number and design.

The dimensions of the measurement ports should allow straight insertion of the virtual impactor into the flue gas duct without any contact with the inner duct walls.

The measurement section should be in accordance with the requirements of the applicable standard.

NOTE Requirements concerning the measurement section are specified, for example, in ISO 12141 or EN 15259.^[9]

The flue gas conditions shall be constant during sampling to ensure that the isokinetic rate is kept between 90 % and 130 % of the calculated value (see 8.3.4).

The virtual impactor shall be used in the flue gas duct with the entry nozzle in the upstream direction (see Figure 5).

Sampling shall be performed at a sampling point representative of the flue gas velocity. This representative sampling point shall be determined in accordance with Annex G.

It shall be guaranteed that the cut-off diameter does not change during sampling. Under constant flue gas conditions, this can be realized by a constant sample gas flow.

8.2 Pre-treatment

8.2.1 Virtual impactor

The virtual impactor shall be cleaned in accordance with the manufacturer's instructions, at intervals specified in the measurement plan.

NOTE Requirements concerning the measurement plan are specified for example in EN 15259.^[9]

All internal surfaces of the virtual impactor shall be cleaned between measurements on site, e.g. with a microfibre cloth.

8.2.2 Collection and backup filters

Preparation of filter sets shall be carried out in the laboratory.

Collection and backup filters shall be placed in uniquely marked holders. Then the collection and backup filters with the holders shall be dried, equilibrated, and weighed in accordance with ISO 12141.

The collection and backup filters shall be stored and transported in closed and clearly labelled boxes.

ISO 13271:2012(E)

8.3 Measurement procedure

8.3.1 Measurement planning

Measurement planning should generally include:

- a) operating conditions of the plant, including fuel or feedstock, flue gas components, and reference quantities (e.g. temperature, pressure, water vapour content to be measured);
- b) sampling date and time and location of measurements;
- c) measurement methods to be applied;
- d) measurement sections and measurement sites;
- e) technical supervisor and necessary personnel for carrying out of the measurements;
- f) reporting procedures.

NOTE Recommendations for testing laboratories are specified, for example, in ISO/IEC 17025.^[5]

The sampling duration depends on the dust concentration and the particle size distribution in the flue gas. If these parameters are unknown, they should be determined by pre-measurements. The sampling duration shall be specified such that overloading of collection and backup filters is avoided and a sufficient dust mass is sampled.

8.3.2 Flue gas data

The following flue gas data shall be determined before a measurement is carried out:

- a) flue gas velocity;
- b) flue gas composition: O₂, CO₂, N₂, water vapour;
- c) temperature;
- d) static pressure.

8.3.3 Determination of the sample gas volume flow rate

The sample gas volume flow rate under operating conditions shall be determined in accordance with 6.4.3. This volume flow rate shall be converted to the conditions at the volume-measuring device. The input quantities for the calculation are the measured values determined in accordance with 8.3.2.

The sample gas volume flow rate shall be monitored and kept constant during sampling within ± 5 % of the nominal value, to ensure that the cut-off characteristics of both separation stages do not change.

8.3.4 Selection of the entry nozzle

The effective diameter of the entry nozzle shall be calculated in accordance with Formula (8).

Sampling shall be carried out with an isokinetic rate between 90 % and 130 % of the calculated value. The entry nozzle shall be selected accordingly. An example of entry nozzle selection is shown in C.2.

8.3.5 Leak check

The sampling system shall be assembled and checked for possible leaks by sealing the entry nozzle and starting the suction device. The leak flow shall be below 2 % of the normal flow rate. This can be measured, for example, by pressure variations after evacuation of the sampling train at the maximum vacuum reached during sampling. During sampling, a leak check can be monitored by continuously measuring the concentration of a relevant gas component (CO₂, O₂, etc.) directly in the duct and downstream of the sampling train. Any

detectable difference between those concentrations indicates a leak in the sampling equipment parts located outside the flue gas duct. This leak shall then be investigated and rectified.

8.3.6 Measurement

The virtual impactor mounted with an appropriate entry nozzle shall be at the flue gas temperature before a measurement is started. If the flue gas temperature is close to the water-vapour dew-point, the complete virtual impactor shall be heated to the flue gas temperature outside the duct.

NOTE The large virtual impactor mass can lead to long heating periods.

During installation, the sampling train shall be inserted into the flue gas duct, such that any contact between the entry nozzle and the flue gas duct is avoided. The measurement ports shall be sealed to minimize oxygen entering the duct or flue gas escaping the duct.

The angle between the centreline of the entry nozzle and the flow direction shall be smaller than 10°. Three shut-off valves shall be opened, the suction device shall be switched on and the volume flow shall be set to the values calculated in 6.4.3.

The volume flow rate shall be checked and recorded at least every 5 min during sampling and shall be adjusted in the case of deviations from the calculated value.

The dynamic pressure shall be continuously checked with a Pitot tube or with another suitable measuring device installed at a fixed location or at the sampling train, or it shall be recorded at least every 5 min.

The sampling train shall be removed from the flue gas duct after sampling. When the static pressure is negative, the virtual impactor shall be removed before stopping the suction device.

The sample volume of the measurement shall be determined and recorded. Each sample volume at three suction devices shall be recorded and the total sample volume shall be calculated.

8.3.7 Filter change

The backup filter holder with the backup filter, and the collection filter holders with the collection filters, shall be removed from the virtual impactor and transferred to the transport containers. Any contamination of the filters shall be avoided.

8.4 Weighing procedure

8.4.1 General

The backup filter and the collection filter of the second stage shall be weighed. The filters shall be weighed with or without their holders. Weighing with a filter holder is highly recommended.

NOTE As a plausibility check, the collection filter of the first stage can be weighed too.

8.4.2 Pre-sampling treatment of weighed parts

Weighed parts shall be dried in a drying oven for at least 1 h at a temperature at least 20 °C above the maximum temperature reached during sampling.

After drying, the filters and/or the filter holders shall be placed in a desiccator located in the weighing room for at least 8 h.

8.4.3 Weighing

Weigh the filter on a suitable electronic balance to within $\pm 0,1$ mg. It is strongly recommended that the same balance be used for both pre-weighing and post-weighing.

ISO 13271:2012(E)

Before performing any weighing series:

- a) calibrate the balance against standard masses;
- b) carry out additional checks by weighing control parts, identical to the parts to be used in the measurement, pre-treated in the same temperature and humidity control conditions and kept free from contamination;
- c) record the equilibration relative humidity and temperature in the room.

An increase or decrease in the weighing result can be due to the following causes.

- 1) Electrostatic charges, which give erratic readings and which should be discharged to earth or neutralized.
- 2) Hygroscopic characteristics of the filter material and/or dust. Weighing shall be carried out within 1 min after removal from the desiccator. Take two additional readings at 5 s intervals after the initial reading. If there is a significant increase or decrease in the readings as a function of time due to the nature of the material, implement special procedures such as extrapolating the reading to initial conditions.
- 3) Small differences in temperature between the part to be weighed and the environment can disturb the balance.

8.5 Post-sampling treatment of weighed parts

For data evaluation, the backup filter and the collection filter of the second stage are used.

The weighed parts shall be dried in an oven for at least 1 h between 100 °C and 120 °C, equilibrated, and weighed in accordance with 8.4.2 and 8.4.3.

9 Calculation of the results

The concentration, $\gamma(\text{PM}_{2,5})$, of $\text{PM}_{2,5}$ in the flue gas shall be calculated by Formula (9):

$$\gamma(\text{PM}_{2,5}) = \frac{m_{\text{BF}}}{V_n} \quad (9)$$

where

m_{BF} is the particle mass on the backup filter;

V_n is the sample volume under standard conditions and for dry gas.

The concentration, $\gamma(\text{PM}_{10})$, of PM_{10} in the flue gas shall be calculated by Formula (10):

$$\gamma(\text{PM}_{10}) = \frac{m_{\text{BF}} + m_{\text{CF2}}}{V_n} \quad (10)$$

where

m_{BF} is the particle mass on the backup filter;

m_{CF2} is the particle mass on the collection filter of the second separation stage;

V_n is the sample volume under standard conditions and for dry gas.

The sample volume, V_n , under standard conditions and for dry gas shall be calculated from the sample volume under the conditions prevailing at the gas volume-measuring device.

The collection filter of the first separation stage shall not be used for the determination of the total dust concentration.

NOTE Virtual impactors always exhibit particle losses. These particle losses are attributed to coarse particles, by convention. If the PM_{2,5} and PM₁₀ fractions in the total dust require determination, an additional parallel total dust measurement is needed.

10 Performance characteristics

10.1 Virtual impactor load

The load of the backup and collection filters of the separation stages shall not exceed the maximum load specified by the manufacturer.

The sampling period depends on the dust concentration and the particle size distribution in the flue gas. Both may be determined in pre-measurements to select a sampling period, which avoids overloading the collection filters and the backup filter.

10.2 Detection limit

The detection limit of the virtual impactor shall be estimated on the basis of the absolute detectable mass on the filter and the nominal sample volume.

The detection limit of PM₁₀ is influenced by two independent weighings (backup filter and collection filter of second stage). Therefore, the detection limit is higher than the value of PM_{2,5}.

10.3 Measurement uncertainty

The measurement uncertainty of the impactor shall be determined in the field by paired measurements with two identical measuring systems. The samples shall be taken at the same measurement point in the measurement cross-section. The standard uncertainty, $u(\gamma)$, shall be calculated by means of Formula (11) in accordance with ISO 20988:[6]

$$u(\gamma) = \sqrt{\frac{1}{2n} \sum_{i=1}^n (\gamma_{1,i} - \gamma_{2,i})^2} \quad (11)$$

where

$\gamma_{1,i}$ is the i th concentration value of the first measuring system;

$\gamma_{2,i}$ is the i th concentration value of the second measuring system;

n is the number of paired measured values.

Determine the measurement uncertainty at least during the validation of the virtual impactor under plant operating and waste-gas conditions, which are representative of the future application of the virtual impactor. The tests shall be carried out by a testing laboratory operating an internationally recognized quality management system.

NOTE Requirements for testing laboratories are specified, for example, in ISO/IEC 17025.[5]

10.4 Particle losses

Particle losses generally occur during particulate sampling when impactors are used. A portion of particles is not separated according to the theory (see Reference [17]) on the collection filter and the backup filter, but diffusively on the walls and the impactor stages. These particles are not taken into account in the mass determination of the fractions considered by convention. As a consequence, the sum of the mass on the collection filters and on the backup filter is usually not identical to the total mass concentration of dust in the flue gas.

ISO 13271:2012(E)

Comprehensive investigations (see References [18][19]) have shown that the loss of particles increases with increased particle size.

NOTE 1 If the individual fractions (PM_{10} and $PM_{2,5}$) are related to the collected mass, the calculated distribution is shifted to smaller particle sizes, since equally distributed particle losses are assumed.

NOTE 2 If the individual fractions (PM_{10} and $PM_{2,5}$) are related to the total dust mass measured at the same time, the calculated distribution is shifted to larger particle sizes, since it is assumed that particle losses are related to coarse particles only. This assumption is close to reality, since it is well known that particle losses are related to the coarse-particle fraction.

11 Test report

The test report shall contain at least the following information:

- a) results of the emission measurements, including the measurement uncertainty;
- b) detailed information on the plant and on all elements relevant for measurement planning (see 8.3.1);
- c) all measured and calculated values and results.

Annex A (informative)

Physical property estimation for the calculation of sample volume flow rate

A.1 Temperature-dependent dynamic viscosity of the gas

For the calculation of the dynamic viscosity under operating conditions, the volume fractions of the different gas constituents shall be determined. Then the dynamic viscosity of the constituents under operating conditions is calculated. The viscosity of the gas mixture is calculated from the viscosities of the constituents.

The dynamic viscosity of the individual gas constituent of the sample gas under operating conditions is given by Formula (A.1):

$$\eta_j(T) = \eta_{n,j} \sqrt{\frac{T}{T_n} \frac{1 + (S_j/T_n)}{1 + (S_j/T)}} \quad (\text{A.1})$$

where

- j identifies the individual constituent of the sample gas ($j = \text{CO}_2, \text{O}_2, \text{N}_2, \text{air, water vapour}$);
- $\eta_j(T)$ is the dynamic viscosity of constituent j under operating conditions;
- $\eta_{n,j}$ is the dynamic viscosity of constituent j at the standard temperature, T_n (constant);
- T is the gas temperature;
- T_n is the standard temperature; $T_n = 273,15 \text{ K}$;
- S_j is the Sutherland constant of constituent j .

The corresponding volume fractions, φ_j , in wet flue gas should be calculated by Formula (A.2) and Formula (A.3), respectively:

- for $j = \text{CO}_2, \text{O}_2, \text{N}_2$, and air:

$$\varphi_j = \varphi_{n,j} \times 1 / \left(1 + \frac{\gamma_{n,\text{H}_2\text{O},v}}{\rho_{n,\text{H}_2\text{O},v}} \right) \quad (\text{A.2})$$

- for $j = \text{water vapour}$:

$$\varphi_{\text{H}_2\text{O}} = \frac{\gamma_{n,\text{H}_2\text{O},v}}{\rho_{n,\text{H}_2\text{O},v}} \times 1 / \left(1 + \frac{\gamma_{n,\text{H}_2\text{O},v}}{\rho_{n,\text{H}_2\text{O},v}} \right) \quad (\text{A.3})$$

where

- $\varphi_{n,j}$ is the volume fraction of constituent j in dry gas;
- $\gamma_{n,\text{H}_2\text{O},v}$ is the mass concentration of water vapour under standard conditions and with dry gas;
- $\rho_{n,\text{H}_2\text{O},v}$ is the density of water vapour under standard conditions (constant).

ISO 13271:2012(E)

The temperature-dependent dynamic viscosity of the gas, $\eta(T)$, under operating conditions shall be calculated by Formula (A.4):

$$\eta(T) = \frac{\sum_j \varphi_j \eta_j(T) \sqrt{M_j T_{\text{crit},j}}}{\sum_j \varphi_j \sqrt{M_j T_{\text{crit},j}}} \quad (\text{A.4})$$

where

φ_j is the volume fraction of constituent j of the gas mixture;

$T_{\text{crit},j}$ is the critical temperature of constituent j (constant);

M_j is the molecular mass of constituent j (constant).

A.2 Cunningham factor

The calculation of the Cunningham factor requires the determination of the mean free path length and the mean molar mass of the gas. The mean free path length, λ , is calculated by Formula (A.5)

$$\lambda = 2 \times \frac{\eta(T)}{p} \sqrt{\frac{\pi RT}{8 \bar{M}}} \quad (\text{A.5})$$

where

$\eta(T)$ is the temperature-dependent viscosity of the gas;

p is the absolute gas pressure;

\bar{M} is the mean molar mass of the gas mixture;

R is the gas constant.

The mean molar mass, \bar{M} , of the sample gas shall be calculated by Formula (A.6):

$$\bar{M} = \sum_j \varphi_j M_j \quad (\text{A.6})$$

The Cunningham factor, $C_{m,i}$, of particle fraction i shall be calculated by Formula (A.7):

$$C_{m,i} = 1 + \frac{2\lambda}{d_{50,i}} \left[1,23 + 0,41 \exp \left(-0,88 \frac{d_{50,i}}{2\lambda} \right) \right] \quad (\text{A.7})$$

where

i identifies the particle fraction ($i = 2,5 \mu\text{m}, 10 \mu\text{m}$);

λ is the mean free path length;

$d_{50,i}$ is the cut-off diameter of particle fraction i .

A.3 Gas density

The density, ρ_{pTf} , of the wet gas under operating conditions is calculated by Formula (A.8):

$$\rho_{pTf} = \frac{(p_{\text{amb}} + p_{\text{st}})T_n(\rho_n + \gamma_{n,\text{H}_2\text{O},v})}{p_n T \left[1 + (\gamma_{n,\text{H}_2\text{O},v} / \rho_{n,\text{H}_2\text{O},v}) \right]} \quad (\text{A.8})$$

The density, ρ_n , of the dry gas mixture is calculated by Formula (A.9):

$$\rho_n = \sum_j \varphi_j \rho_{n,j} \quad (\text{A.9})$$

where

- φ_j is the volume fraction of constituent j of the gas mixture;
- T_n is the standard temperature, $T_n = 273,15$ K;
- p_{amb} is the ambient pressure at the measurement site;
- p_n is the standard pressure; $p_n = 1\,013,25$ hPa;
- p_{st} is the difference between the static pressure in the measurement cross-section and the atmospheric pressure at the measurement site (barometric pressure);
- $\gamma_{n,\text{H}_2\text{O},v}$ is the mass concentration of water vapour under standard conditions and with dry gas.

A.4 Constants

Table A.1 — Constants required for the calculations

Constant	Symbol	Value	Unit
Gas constant	R	8,314 51	J/(mol K)
Standard temperature	T_n	273,15	K
Standard pressure	p_n	1 013, 25	hPa
Density of CO ₂ under standard conditions	ρ_{n,CO_2}	1,977	kg/m ³
Density of O ₂ under standard conditions	ρ_{n,O_2}	1,429	kg/m ³
Density of N ₂ under standard conditions	ρ_{n,N_2}	1,251	kg/m ³
Density of dry air under standard conditions	$\rho_{n,\text{air}}$	1,293	kg/m ³
Density of water vapour under standard conditions	$\rho_{n,\text{H}_2\text{O},v}$	0,804	kg/m ³
Particle density	$\rho_{0,P}$	1 000	kg/m ³
Dynamic viscosity of CO ₂	η_{n,CO_2}	$1,370 \times 10^{-5}$	kg/ms
Dynamic viscosity of O ₂	η_{n,O_2}	$1,928 \times 10^{-5}$	kg/ms
Dynamic viscosity of N ₂	η_{n,N_2}	$1,652 \times 10^{-5}$	kg/ms
Dynamic viscosity of air	$\eta_{n,\text{air}}$	$1,717 \times 10^{-5}$	kg/ms
Dynamic viscosity of water vapour	$\eta_{n,\text{H}_2\text{O},v}$	$8,660 \times 10^{-6}$	kg/ms
Molar mass of CO ₂	M_{n,CO_2}	44,01	g/mol

ISO 13271:2012(E)

Table A.1 (continued)

Constant	Symbol	Value	Unit
Molar mass of O ₂	M_{n,O_2}	32,00	g/mol
Molar mass of N ₂	M_{n,N_2}	28,02	g/mol
Mean molar mass of dry air	\bar{M}_{air}	28,97	g/mol
Molar mass of water vapour	$M_{H_2O,v}$	18,02	g/mol
Sutherland constant of CO ₂	S_{CO_2}	273	K
Sutherland constant of O ₂	S_{O_2}	125	K
Sutherland constant of N ₂	S_{N_2}	104	K
Sutherland constant of air	S_{air}	113	K
Sutherland constant of water vapour	$S_{H_2O,v}$	650	K
-	$\sqrt{M_{CO_2} T_{crit,CO_2}}$	115,7	$\sqrt{g \text{ mol}^{-1} K}$
-	$\sqrt{M_{O_2} T_{crit,O_2}}$	70,4	$\sqrt{g \text{ mol}^{-1} K}$
-	$\sqrt{M_{N_2} T_{crit,N_2}}$	59,5	$\sqrt{g \text{ mol}^{-1} K}$
-	$\sqrt{\bar{M} T_{crit,air}}$	61,9	$\sqrt{g \text{ mol}^{-1} K}$
-	$\sqrt{M_{H_2O} T_{crit,H_2O,v}}$	107,9	$\sqrt{g \text{ mol}^{-1} K}$

Annex B (informative)

Errors by deviations from isokinetic sampling

In addition to the measurement uncertainty determined by multiple determinations in repeatability or reproducibility conditions, further uncertainty contributions are caused by sampling at only one measurement point in the cross-section or by deviations from isokinetic sampling.

It is assumed that all measurements are carried out at a sampling point which represents the conditions in the measurement cross-section. Therefore, this uncertainty contribution should be neglected.

The diameter of the entry nozzle for isokinetic sampling can only be estimated, since the volume flow through the impactor is calculated before the measurement and should be kept constant during sampling. The corresponding contributions to measurement uncertainty can be estimated theoretically for different particle sizes.

The collection efficiency of a sampling system for particles with different aerodynamic diameters should be calculated from the isokinetic rate (see Reference [19]). Figure B.1 shows examples of collection efficiencies of different particle fractions as a function of the ratio of the gas velocity in the entry nozzle to the flue gas velocity in the duct. The calculations were based on ambient air with a gas velocity of 10 m/s and an entry nozzle diameter of 10 mm.

NOTE The collection efficiency is the ratio of the sampled concentration sampled at a specific isokinetic rate to the concentration at isokinetic sampling with an isokinetic rate 1,0.

To meet the given cut-off limits of 10 µm and 2,5 µm particle diameters, the virtual impactor shall be operated with a constant sample volume flow rate to be previously determined. The volume flow rate only depends on the flue gas conditions which can be calculated. Isokinetic sampling should be established by selection of an appropriate sampling nozzle diameter. If not, sampling shall be carried out with an isokinetic rate between 90 % and 130 % of the calculated value based on Davis's Formulae (B.1) and (B.2) (see Reference [19]) as shown in Figure B.1. (Isokinetic rate is the ratio of the gas velocity in the entry nozzle, v_{entry} , to the flue gas velocity, v_{fg} .) The entry nozzle shall be selected accordingly.

$$E = \frac{\gamma_i}{\gamma_a} = \frac{v_{\text{fg}}}{v_{\text{entry}}} - \frac{1}{1 + 2St_{\text{entry}}} \left(\frac{v_{\text{fg}}}{v_{\text{entry}}} - 1 \right) \quad (\text{B.1})$$

$$St_{\text{entry}} = \frac{d_{\text{ae}}^2 \rho_{0,P} v_{\text{fg}}}{9\eta d_{\text{entry}}} \quad (\text{B.2})$$

where

- γ_i is the dust concentration by isokinetic sampling;
- γ_a is the dust concentration by anisokinetic sampling;
- v_{fg} is the flue gas velocity;
- v_{entry} is the gas velocity in the entry nozzle;
- η is the viscosity of the gas;
- d_{entry} is the internal nozzle diameter at the inlet;
- $\rho_{0,P}$ is the particle density (1 g/cm³);

ISO 13271:2012(E)

St_{entry} is the Stokes's number;

d_{ae} is the aerodynamic diameter.

NOTE Over-isokinetic sampling is preferred since the error in the collection efficiency is smaller than for sampling below isokinetic rate, as shown in Figure B.1.

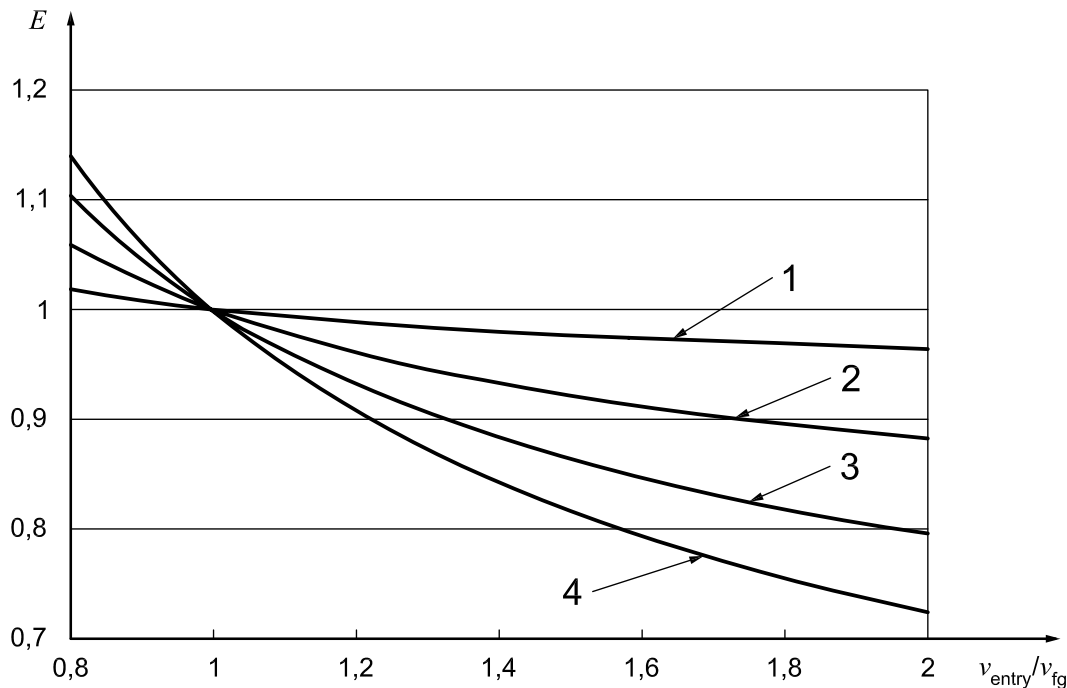

Key		aerodynamic diameter, d_{ae}
E	dust concentration error by anisokinetic sampling	1 2,5 μm
v_{entry}	gas velocity in the entry nozzle	2 5,0 μm
v_{fg}	flue gas velocity	3 8,0 μm
		4 10,0 μm

Figure B.1 — Theoretical dependence of dust concentration error on the ratio of the gas velocity in the entry nozzle to the flue gas velocity

For particles with an aerodynamic diameter $d_{ae} = 10 \mu\text{m}$ (not to be confused with PM_{10}) and over-isokinetic sampling with a factor of 1,5, the findings are reduced by approximately 15 %. This error decreases with decreasing particle size and should be nearly negligible at $d_{ae} = 2,5 \mu\text{m}$.

The error caused by deviations from the isokinetic sampling is significantly smaller than the maximum values given in the preceding, which were calculated for a particle size of $10 \mu\text{m}$, since the particles usually have a size distribution when emission measurements are carried out in purified flue gas.

Annex C (informative)

Example of a two-stage virtual impactor

C.1 Design and characteristic data

Figure C.1 shows an example of a two-stage virtual impactor without entry nozzle (see Annex E). The characteristic data of the virtual impactor are given in Table C.1. This impactor is a laminar flow unit, with overall internal losses typically below 10 % per stage.

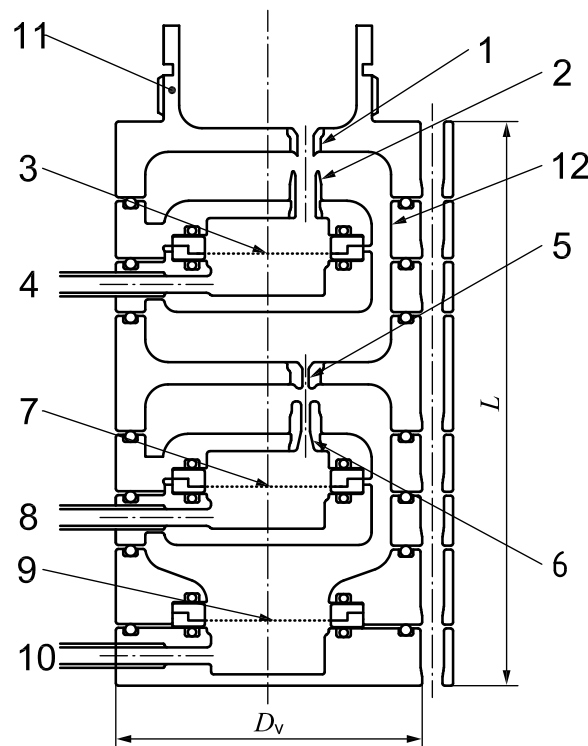

- 1 PM_{10} acceleration nozzle
 - 2 collection nozzle for the particles greater than $10\ \mu m$
 - 3 collection filter for the particles greater than $10\ \mu m$, CF1
 - 4 suction tube for coarse particles
 - 5 $PM_{2,5}$ acceleration nozzle
 - 6 collection nozzle for the particles between $2,5\ \mu m$ and $10\ \mu m$
 - 7 collection filter for particle fractions $>2,5\ \mu m$ and $<0\ \mu m$, CF2
 - 8 suction tube
 - 9 backup filter for particle fraction $<2,5\ \mu m$, BK
 - 10 suction tube
 - 11 attachment of exchangeable entry nozzle (Annex E)
 - 12 annular flow channel
- D_v diameter
 L length

Figure C.1 — Basic design of a two-stage virtual impactor

ISO 13271:2012(E)

Table C.1 — Characteristic data of the virtual impactor

Parameter	Impactor	PM ₁₀ stage (<i>i</i> = 10 μm, <i>j</i> = 1)	PM _{2,5} stage (<i>i</i> = 2,5 μm, <i>j</i> = 2)
Length with entry nozzle attached	~248 mm		
Diameter	~70 mm		
Sample volume flow rate, q_V		12,5 l/min	
Number of nozzles, N_i		6	6
Particle acceleration nozzle diameter, $D_{0,i}$		3,9 mm	1,5 mm
Particle collection nozzle diameter, $D_{1,i}$		5,1 mm	2,0 mm
Distance between the end of the particle acceleration nozzle and the top of the particle collection nozzle, s_i		3,5 mm	2,5 mm
Particle acceleration nozzle length, $l_{0,i}$		5,0 mm	4,0 mm
Stokes's number, $St_{50,i}$		0,46	0,49
Total flow rate per stage, $q_{V0,i} \times N_i = q_V$		12,5 l/min	11,5 l/min
Minor flow rate per stage, $q_{V1,i} \times N_i = q_{V,CF_j}$		1,0 l/min	1,2 l/min
Velocity in the nozzles, v_i		2,9 m/s	18,1 m/s
Reynolds number in the particle acceleration nozzles (20 °C, atmospheric air)		750	1 800

C.2 Entry nozzle diameter selection

Based on Formula (8), an example of the relation between flue gas velocity and applicable entry nozzle diameter of a virtual impactor illustrated in Figure C.1 and Table C.1 is shown in Table C.2.

Table C.2 — Relation between flue gas velocity and applicable entry nozzle diameter (air at ambient conditions)

Entry nozzle diameter mm	Range of flue gas velocity m/s	Entry nozzle diameter mm	Range of flue gas velocity m/s
3	22,7–32,7	7	4,2–6,0
3,5	16,7–24,1	8	3,2–4,6
4	12,8–18,4	9	2,5–3,6
4,5	10,1–14,6	10	2,0–2,9
5	8,2–11,8	12	1,4–2,0
6	5,7–8,2	14	1,0–1,5

C.3 Separation curve

Figure C.2 shows experimentally determined separation curves. To check that the separation of the impactor stages corresponds to the calculated separation efficiencies, experiments have been performed as specified in Annex H. The separation efficiency curves satisfy the condition indicated in Table 1.

C.4 Detection limit

The detection limit of weighing the separate filters (backup filter and collection filter of the second separation stage) is 0,3 mg. The detection limit of weighing PM_{2,5} is, correspondingly, 0,3 mg. The detection limit of the concentration for a sample volume of 1 m³ is 0,3 mg/m³.

Since the detection limit of PM₁₀ is influenced by two independent weighings (backup filter and collection filter of the PM_{2,5} stage), the detection limit of 0,4 mg is higher than the value of PM_{2,5}. Due to uncertainty propagation, the corresponding detection limit of the concentration for a sample volume of 1 m³ is 0,4 mg/m³.

C.5 Measurement uncertainty

Tables C.3 and C.4 give standard uncertainties by paired measurements calculated by Formula (11). These standard uncertainties take into account influences such as sampling the differential weighing of collection filters and backup filters.

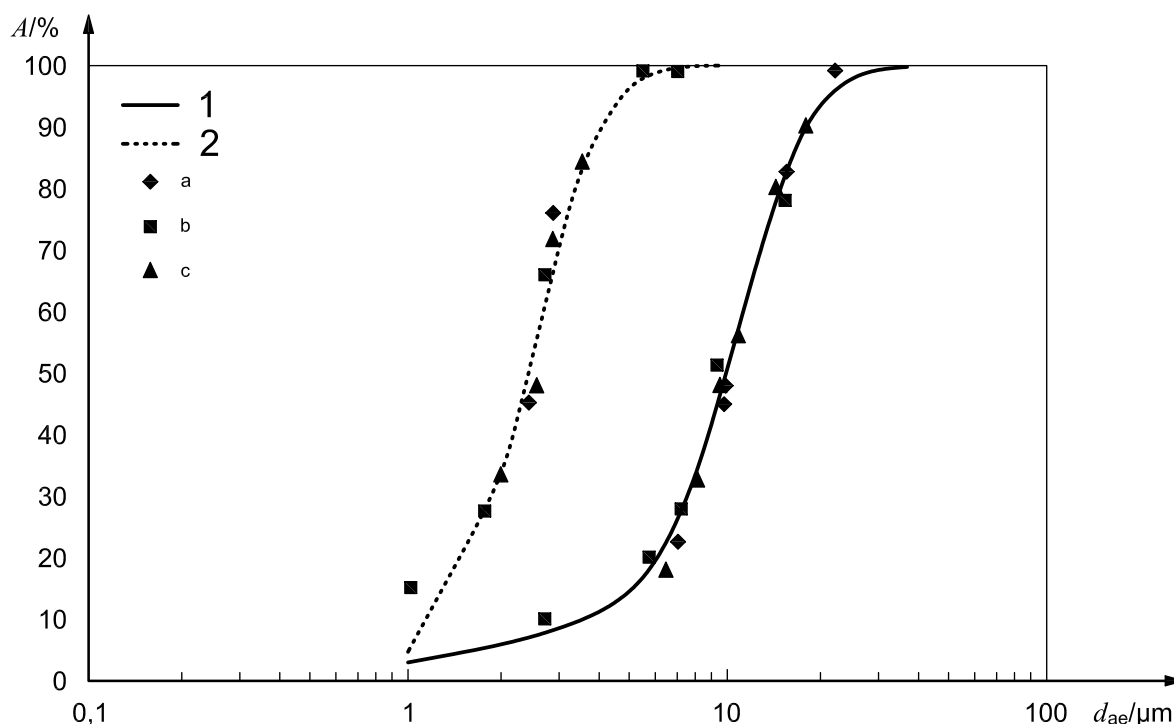

Key

<i>A</i>	separation efficiency	1	ISO 7708 ^[1] thoracic	a	Without cap.
<i>d_{ae}</i>	aerodynamic diameter	2	ISO 7708 ^[1] high-risk respirable	b	With cap.
				c	Prototype.

Figure C.2 — Examples of separation efficiency curves of multistage virtual impactor with multiple nozzles (Reference [10])

Table C.3 — Standard uncertainty from paired measurements (one operator of the method)

Plant type	Number of paired measurements <i>n</i>	Average PM ₁₀ content mg/m ³	Standard uncertainty of PM ₁₀ content mg/m ³	Average PM _{2,5} content mg/m ³	Standard uncertainty of PM _{2,5} content mg/m ³
Gas-flow channel	7	31,9	2,1	2,4	0,4
Waste incineration plant	3	6,4	0,8	5,8	0,9
Heavy oil and natural gas co-combustion boiler	3	3,8	0,6	1,5	0,3

ISO 13271:2012(E)

Table C.4 — Standard uncertainty from paired measurements (two operators of the method)

Plant type	Number of paired measurements <i>n</i>	Average PM₁₀ content mg/m ³	Standard uncertainty of PM₁₀ content mg/m ³	Average PM_{2,5} content mg/m ³	Standard uncertainty of PM_{2,5} content mg/m ³
Gas-flow channel	7	51,8	4,4	3,4	0,6

Annex D (informative)

Influence of variations in the flue gas temperature and flue gas composition on the Reynolds number

The Reynolds numbers, Re_i , in the particle acceleration nozzles, whose diameter is $D_{0,i}$, are calculated by Formula (D.1):

$$Re_i = \frac{v_i D_{0,i} \rho_{pTf}}{\eta} \quad (D.1)$$

For major flow, $qv_{2,i}$, through annular flow channels (see Figure C.1) of each stage, the Reynolds numbers, $Re_{ann,i}$, in the annular flow channels are calculated by Formula (D.2):

$$Re_{ann,i} = \frac{v_{ann,i} d_{ann,i} \rho_{pTf}}{\eta} \quad (D.2)$$

The diameter of the annular flow channel, d_{ann} , is calculated by Formula (D.3):

$$d_{ann} = \frac{4A_{ann}}{\pi(d_{ann,1} + d_{ann,2})} \quad (D.3)$$

Substituting gas velocity in annular flow channel, $v_{ann,i} = qv_{2,i} \times N_i/A_{ann}$ and Formula (D.3) into Formula (D.2);

$$Re_{ann,i} = \frac{4\rho_{pTf} qv_{2,i} N_i}{\pi(d_{ann,1} + d_{ann,2})\eta} \quad (D.4)$$

where

- i identifies the particle fraction ($i = 2,5 \mu\text{m}, 10 \mu\text{m}$);
- v_i is the gas velocity in the particle acceleration nozzles at stage i ;
- $v_{ann,i}$ is the gas velocity in the annular flow channel at stage i ;
- Re_i is the Reynolds number at stage i ;
- ρ_{pTf} is the gas density under operating conditions;
- $D_{0,i}$ is the diameter of the particle acceleration nozzles at stage i (constant);
- d_{ann} is the equivalent diameter of the annular flow channels (constant);
- η is the dynamic viscosity of the gas under operating conditions;
- A_{ann} is the annular flow channels area;
- $d_{ann,1}$ is the inner diameter of the annular flow channel;
- $d_{ann,2}$ is the outer diameter of the annular flow channel;
- $qv_{2,i}$ is the major gas flow rate per impactor nozzle;
- N_i is the number of impactor nozzles at stage i .

The following example illustrates the influence of variations in the flue gas temperature and flue gas composition on the Reynolds number. Input data have been obtained from the measurement of $PM_{10}/PM_{2,5}$ at a commercial

ISO 13271:2012(E)

coal-fired plant with an impactor shown in Annex C (Reference [20]). These calculations illustrate that a variation in the flue gas temperature has the highest influence on the Reynolds number. Reynolds numbers, Re , of the gas flow in the particle acceleration nozzle are in the region of laminar flow ($100 < Re < 3\ 000$). Reynolds numbers at the annular-flow channel are sufficiently low.

Table D.1 — Flue gas conditions and sampling conditions

Flue gas conditions	Flue gas velocity	25,6 m/s
	Flue gas temperature	158 °C
	Flue gas pressure	103 kPa (1 030 mbar)
	O ₂ volume fraction (dry)	6,6 %
	CO ₂ volume fraction (dry)	12,8 %
	N ₂ volume fraction (dry)	80,6 %
	Flue gas water-vapour content	56,8 g/m ³
Sampling conditions	Total volumetric flow rate at flue gas conditions	14,3 l/min
	Total volumetric flow rate under standard conditions	9,22 l/min
	Suction gas flow rate from particle collection nozzles of PM ₁₀ stage under standard conditions	0,86 l/min
	Suction gas flow rate from particle collection nozzles of PM _{2,5} stage under standard conditions	1,08 l/min
	Entry nozzle diameter	3,5 mm

Table D.2 — Reynolds numbers for different flue gas temperatures

Variation in flue gas temperature	Reynolds number	
	for 2,5 µm	for 10 µm
15 K lower flue gas temperature	1 297	542
10 K lower flue gas temperature	1 280	535
5 K lower flue gas temperature	1 264	528
Start value (158 °C)	1 249	522
5 K higher flue gas temperature	1 233	516
10 K higher flue gas temperature	1 218	509
15 K higher flue gas temperature	1 204	503

Table D.3 — Reynolds number for different flue gas of CO₂ composition

Variation in CO ₂ volume fraction	Reynolds number	
	for 2,5 µm	for 10 µm
1,5 % lower CO ₂ volume fraction	1 241	519
1,0 % lower CO ₂ volume fraction	1 243	520
0,5 % lower CO ₂ volume fraction	1 246	521
Start value (12,8 % CO ₂ volume fraction)	1 249	522
0,5 % higher CO ₂ volume fraction	1 251	523
1,0 % higher CO ₂ volume fraction	1 254	524
1,5 % higher CO ₂ volume fraction	1 256	525

Table D.4 — Reynolds number for different flue gas of water-vapour composition

Variation in water-vapour volume fraction	Reynolds number	
	for 2,5 µm	for 10 µm
1,5 % lower water-vapour volume fraction	1 256	525
1,0 % lower water-vapour volume fraction	1 253	524
0,5 % lower water-vapour volume fraction	1 251	523
Start value (6,6 % water-vapour volume fraction)	1 249	522
0,5 % higher water-vapour volume fraction	1 246	521
1,0 % higher water-vapour volume fraction	1 244	520
1,5 % higher water-vapour volume fraction	1 241	519

Annex E (informative)

Entry nozzle

Figure E.1 shows an example of entry nozzle in accordance with ISO 12141 with an acceptable design for stack measurements of total dust with plane filter devices and measurements of PM₁₀/PM_{2,5} mass concentration with the impactor described in Clause 6. The following characteristics should be fulfilled:

- wall thickness, δ , of the nozzle at the inlet: $\delta < d_{\text{entry}}/12$, but at least 0,8 mm;
- length l with constant internal diameter: $l \geq 10$ mm;
- radius r_{entry} of the nozzle entry edge: $r_{\text{entry}} \leq 0,2$ mm;
- effective diameter: $D_{\text{eff}} = d_{\text{entry}} + 2r_{\text{entry}}$;
- cone angle: $\alpha \leq 30^\circ$.

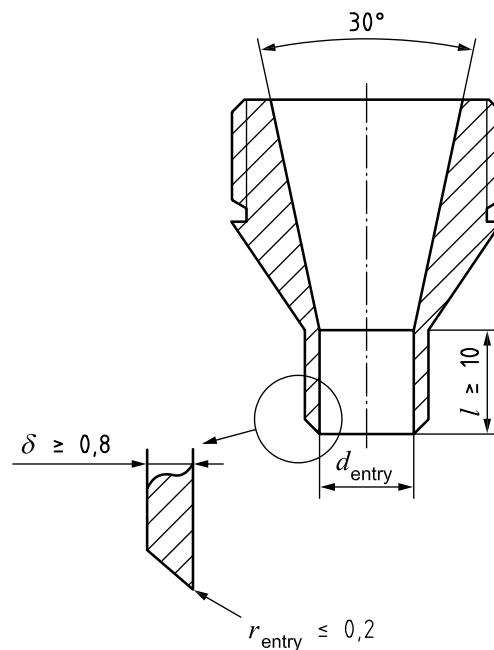

Key

δ	wall thickness of the entry nozzle	l	length with constant internal diameter
d_{entry}	internal diameter of the entry nozzle	r_{entry}	radius of the nozzle entry edge

Figure E.1 — Example of an entry nozzle

Annex F (informative)

Equipment list

Table F.1 — Impactor and entry nozzles

Equipment	Type and/or characteristic
Impactor	corrosion-proof material, e.g. titanium or stainless steel, ISO 15510, ^[3] L-32
Entry nozzle	effective diameter: 3 mm to 18 mm (see Annex E); material: same as impactor

Table F.2 — Equipment for extraction and adjustment of the sample volumetric flow rate

Equipment	Type and/or characteristic
Gas-carrying flexible tube	—
Support parts with stable tube or rod for virtual impactor setting	corrosion-proof material; for lengths over 1 m, a sufficiently stable supporting tube or rod can be needed
Condensate trap	depending on the gas properties, a condensate trap should be used to avoid back-flow of condensate to the measuring filter; heating or cooling shall be provided, if necessary
Drying tower	filled with desiccant
Suction device	e.g. a corrosion-proof gastight pump with protective filter and minimum delivery output of 2 m ³ /h (at 400 hPa at suction side)
Gas volume meter	e.g. one of nominal capacity 3 m ³ /h and two of nominal capacity 1 m ³ /h
Sample gas flowmeter	e.g. rotameter
Temperature-measuring device	for the sample gas flow
Pressure-measuring device	for measuring the atmospheric pressure at the measurement site
Pressure-measuring device for duct and gas flowmeter	for static pressure or static differential pressure between the pressure measurement point and the atmosphere at the measurement site
Time-measuring device	—
Shut-off and control valves	for adjustment of the sample gas flow

Table F.3 — Equipment for measuring the gas velocity, gas composition and reference quantities

Equipment	Type and/or characteristic
Gas-velocity-measuring device	e.g. Pitot tube with micromanometer
Gas analysers	for determining CO ₂ and O ₂ in the flue gas
Temperature-measuring device	for the flue gas
Device for measuring water-vapour content	for the flue gas

Table F.4 — Accessories for pre-treatment and post-treatment in the laboratory

Equipment	Type and/or characteristic
Scales	e.g. measuring range: 60 g, resolution: 0,01 mg
Drying chamber	—
Transport container	for the measuring filters
Heater, if needed	for heating up the complete impactor

ISO 13271:2012(E)

Table F.5 — Working materials

Equipment	Type and/or characteristic
Plane filter	of quartz-fibre material
Drying agent	e.g. silica gel with colour indicator

Annex G (normative)

Determination of a representative sampling point

Determine a representative sampling point in the measurement plane by a grid measurement. Since the measurand also varies in time due to fluctuation in the process, additional parallel measurements with an independent measuring system at a fixed point in the measurement section shall be performed.

NOTE 1 The distribution of measurands in the flue gas can still be inhomogeneous, even when a homogenous flue gas velocity distribution has been observed.

NOTE 2 Homogeneity can be demonstrated for the measurand considered or for a surrogate parameter, for example continuously measured temperature or oxygen distribution in the measurement plane.

The following procedure shall be applied to determine a representative sampling point in the measurement plane:

- a) determine the sampling point for the grid measurement in accordance with ISO 12141;

NOTE 3 The corresponding requirements are identical to those in EN 15259.^[9]

- b) install the probe of the measuring system for the grid measurement;
- c) install the probe of an independent measuring system (reference measurement) at a fixed point in the measurement section;
- d) adjust the sample flow in both systems in order to obtain equal response times;
- e) perform a grid measurement and, in parallel, measurements at a fixed point in the measurement section, with a sampling time of at least four times the response time of the measuring system, but not less than 3 min for each sampling point;

NOTE 4 According to ISO 14956,^[2] the sampling time at each point is four times the response time for dynamic processes and 10 times the response time for highly dynamic processes.

NOTE 2 If there are substantial variations in the actual reference value in time, the inhomogeneity cannot be distinguished from the effects due to process variations. Therefore, the process conditions should be as stable as possible during the grid measurements.

- f) record, for each sampling point, i , the actual value, $y_{i,\text{grid}}$, of the grid measurement and the value, $y_{i,\text{ref}}$, of the reference measurement;
- g) calculate, for each sampling point, i , the ratio r_i according to Formula (G.1):

$$r_i = \frac{y_{i,\text{grid}}}{y_{i,\text{ref}}} \quad (\text{G.1})$$

where

$y_{i,\text{grid}}$ is the i th actual value at the grid measurement;

$y_{i,\text{ref}}$ is the i th reference value measured at a fixed point.

- h) calculate the average, \bar{r} , of the ratios, r_i , according to Formula (G.2):

ISO 13271:2012(E)

$$\bar{r} = \frac{1}{N} \sum_{i=1}^N r_i \quad (\text{G.2})$$

where

- N is the number of total sampling points;
- r_i is the i th ratio at the grid measurement;
- i is sampling point number.

The grid point with the ratio, r_i , nearest to the average value, \bar{r} , of the ratios is assumed to be the representative sampling point.

Annex H (informative)

Generation of standard aerosol for virtual impactor calibration

H.1 General

Calibration is needed to guarantee the cut-off performance of a two-stage virtual impactor. Appropriate aerosol generators assisted by mechanical or electrical power [e.g. vibrating orifice aerosol generator (VOAG), nebulizers] should be used for calibration. The following are examples of methods for generating aerosols composed of oleic acid, polystyrene latex (PSL), and glass spheres of diameters within the 1 µm to 20 µm range.

H.2 VOAG method

To generate aerosol particles of diameters within the 1 µm to 20 µm range, oleic acid particles tagged with uranine are generated from a liquid solution using a VOAG (References [10]–[12]). The aerosols generated are diluted with filtered air and neutralized before being introduced into the impactor. The uranine concentration is measured using a fluorometer.

H.3 Nebulizer method

H.3.1 Polystyrene latex

A pneumatic nebulizer is used to nebulize suspensions containing deionized water and PSL spheres. The PSL particles generated are injected into a 10 l chamber and diluted with dry and filtered air before being introduced into the impactor. This method is suitable for generating aerosol particles of diameters in the range 1,8 µm to 4,6 µm (Reference [13]). PSL particles within this range can also be generated using a VOAG (Reference [13]).

H.3.2 Glass spheres

A nebulizer can also be used to create an aerosol from an aqueous suspension of either hollow or solid glass spheres (Reference [14]). The nominal sizes of the hollow and solid glass spheres are 2 µm to 20 µm and 3 µm to 10 µm respectively. A mass of 1,0 g of glass sphere particles per 200 ml of distilled water is continuously mixed with a magnetic stirrer and nebulized using a pressure-assisted device, and then dried and diluted using dry, particle-free ambient air before introducing into the impactor.

Bibliography

- [1] ISO 7708:1995, *Air quality — Particle size fraction definitions for health-related sampling*
- [2] ISO 14956, *Air quality — Evaluation of the suitability of a measurement procedure by comparison with a required measurement uncertainty*
- [3] ISO 15510, *Stainless steels — Chemical composition*
- [4] ISO 15767:2009, *Workplace atmospheres — Controlling and characterizing uncertainty in weighing collected aerosols*
- [5] ISO/IEC 17025:2005, *General requirements for the competence of testing and calibration laboratories*
- [6] ISO 20988, *Air quality — Guidelines for estimating measurement uncertainty*
- [7] ISO 23210:2009, *Stationary source emissions — Determination of PM₁₀/PM_{2,5} mass concentration in flue gas — Measurement at low concentrations by use of impactors*
- [8] ISO 80000-11:2008, *Quantities and units — Part 11: Characteristic numbers*
- [9] EN 15259:2007, *Air quality — Measurement of stationary source emissions — Requirements for measurement sections and sites and for the measurement objective, plan and report*
- [10] SZYMANSKI W. W., LIU B. Y. H. An airborne particle sampler for the space shuttle. *J. Aerosol Sci.* 1989, **20**, pp. 1569–1572
- [11] KWON S. B., LIM K. S., JUNG J. S., BAE G. N., LEE K. W. Design and calibration of a 5-stage cascade impactor (K-JIST cascade impactor). *J. Aerosol Sci.* 2003, **34**, pp. 289–300
- [12] LOO B. W., CORK C. P. Development of high efficiency virtual impactors. *Aerosol Sci. Technol.* 1988, **9**, pp. 167–176
- [13] PETERS T. M., VANDERPOOL R. W., WEINER R. W. Design and calibration of the EPA PM_{2,5} well impactor ninety-six (WINS). *Aerosol Sci. Technol.* 2001, **34**, pp. 389–397
- [14] DEMOKRITOU P., LEE S. J., FERGUSON S. T. KOUTRAKIS, P. A compact multistage (cascade) impactor for the characterization of atmospheric aerosols. *J. Aerosol Sci.* 2004, **35**, pp. 281–299
- [15] MARPLE V. A. LIU B. Y. H. Characteristics of laminar jet impactors. *Environ. Sci. Technol.* 1974, **8**, pp. 648–654
- [16] MARPLE V. A., CHIEN C. M. Virtual impactors: A theoretical study. *Environ. Sci. Technol.* 1980, **14**, pp. 976–984
- [17] CHEN B. T., YEH H. C., CHENG Y. S. Performance of a modified virtual impactor. *Aerosol Sci. Technol.* 1986, **5**, pp. 369–376
- [18] NOVICK V. J., ALVAREZ J. L. Design of a multistage virtual impactor. *Aerosol Sci. Technol.* 1987, **6**, pp. 63–70
- [19] DAVIES C. N. The entry of aerosols into sampling tubes and heads. *Br. J. Appl. Phys. (J. Phys. D)* 1968, **1**, pp. 921–932
- [20] KAMIYA H., TSUKADA M., LENGGORO W., SZYMANSKI W. W. Fine and nanometer scaled particle behaviour characterization and control for sustainable energy and environmental technology, *Proceedings of 7th International Symposium on Gas Cleaning at High Temperature*, New Castle Australia, 2008-06-23/25

ISO 13271:2012(E)

ICS 13.040.40

Price based on 40 pages