

---

---

**Thermoplastics piping systems for non-pressure underground drainage and sewerage — Thermoplastics shafts or risers for inspection chambers and manholes — Determination of resistance against surface and traffic loading**

*Systèmes de canalisations thermoplastiques pour branchements et collecteurs d'assainissement enterrés sans pression — Éléments de réhausse thermoplastiques pour boîtes d'inspection et de branchement ou regards — Détermination de la résistance aux charges de remblai et de circulation*



**PDF disclaimer**

This PDF file may contain embedded typefaces. In accordance with Adobe's licensing policy, this file may be printed or viewed but shall not be edited unless the typefaces which are embedded are licensed to and installed on the computer performing the editing. In downloading this file, parties accept therein the responsibility of not infringing Adobe's licensing policy. The ISO Central Secretariat accepts no liability in this area.

Adobe is a trademark of Adobe Systems Incorporated.

Details of the software products used to create this PDF file can be found in the General Info relative to the file; the PDF-creation parameters were optimized for printing. Every care has been taken to ensure that the file is suitable for use by ISO member bodies. In the unlikely event that a problem relating to it is found, please inform the Central Secretariat at the address given below.



**COPYRIGHT PROTECTED DOCUMENT**

© ISO 2010

All rights reserved. Unless otherwise specified, no part of this publication may be reproduced or utilized in any form or by any means, electronic or mechanical, including photocopying and microfilm, without permission in writing from either ISO at the address below or ISO's member body in the country of the requester.

ISO copyright office  
Case postale 56 • CH-1211 Geneva 20  
Tel. + 41 22 749 01 11  
Fax + 41 22 749 09 47  
E-mail [copyright@iso.org](mailto:copyright@iso.org)  
Web [www.iso.org](http://www.iso.org)

Published in Switzerland

## Foreword

ISO (the International Organization for Standardization) is a worldwide federation of national standards bodies (ISO member bodies). The work of preparing International Standards is normally carried out through ISO technical committees. Each member body interested in a subject for which a technical committee has been established has the right to be represented on that committee. International organizations, governmental and non-governmental, in liaison with ISO, also take part in the work. ISO collaborates closely with the International Electrotechnical Commission (IEC) on all matters of electrotechnical standardization.

International Standards are drafted in accordance with the rules given in the ISO/IEC Directives, Part 2.

The main task of technical committees is to prepare International Standards. Draft International Standards adopted by the technical committees are circulated to the member bodies for voting. Publication as an International Standard requires approval by at least 75 % of the member bodies casting a vote.

Attention is drawn to the possibility that some of the elements of this document may be the subject of patent rights. ISO shall not be held responsible for identifying any or all such patent rights.

ISO 13266 was prepared by Technical Committee ISO/TC 138, *Plastics pipes, fittings and valves for the transport of fluids*, Subcommittee SC 1, *Plastics pipes and fittings for soil, waste and drainage (including land drainage)*.

© ISO 2010. All rights reserved

www.iso.org

# Thermoplastics piping systems for non-pressure underground drainage and sewerage — Thermoplastics shafts or risers for inspection chambers and manholes — Determination of resistance against surface and traffic loading

## 1 Scope

This International Standard specifies a method of testing the resistance of the upper assembly of inspection chambers and manhole components against surface and traffic loading.

It is not applicable to requirements for testing the cover and frame. Those requirements are specified in EN 124 or other standards, depending on the material.

NOTE Upper assembly components normally include riser shafts, tapers, reducing slabs and telescopic joints.

## 2 Normative references

The following referenced documents are indispensable for the application of this document. For dated references, only the edition cited applies. For undated references, the latest edition of the referenced document (including any amendments) applies.

ISO 13260, *Thermoplastics piping systems for non-pressure underground drainage and sewerage — Test method for resistance to combined temperature cycling and external loading*

EN 124, *Gully tops and manhole tops for vehicular and pedestrian areas — Design requirements, type testing, marking, quality control*

ENV 1046, *Plastics piping and ducting systems — Systems outside building structures for the conveyance of water or sewage — Practices for installation above and below ground*

## 3 Terms and definitions

For the purposes of this document, the following terms and definitions apply.

### 3.1

#### **inspection chamber**

drainage or sewerage fitting used to connect drainage or sewerage installations and to change the direction of drainage or sewerage runs, which terminates at ground level and has a riser shaft with a minimum outer diameter of 200 mm and an inner diameter of less than 800 mm

NOTE The termination at ground level permits the introduction of cleaning, inspection and test equipment and the removal of debris, but does not provide access for personnel.

**3.2  
manhole**

drainage or sewerage fitting used to connect drainage or sewerage installations and/or to change the direction of drainage or sewerage runs, which terminates at ground level and has a riser shaft with a minimum inner diameter of 800 mm

NOTE The termination at ground level permits the introduction of cleaning, inspection and test equipment and the removal of debris, and provides access for personnel.

**4 Principle**

A test assembly comprising at least the first 1 m of chamber or manhole components, measured from and including any component or recommended installation assembly detail at the top end of the inspection chamber or manhole, is buried either in a soil box or under field conditions and a load is applied (see Figure 1).

During loading, the vertical displacement of the cover assembly is measured. After the test is finished, the test assembly is visually inspected and checked for defects.

The referring standard can require test conditions that differ from those set in this International Standard for the following test parameters:

- a) the number of test pieces (see Clause 6);
- b) the maximum load (see Clause 9);
- c) the soil group of granular surround (see Clause 9);
- d) the compaction of the granular surround (see Clause 9).

**5 Apparatus**

**5.1 Soil box**, large enough to accommodate at least the first 1 m of the test assembly and such that at all sides of the assembly a free space of 300 mm minimum is available. The box shall conform to the rigidity and other general requirements specified in ISO 13260.

**5.2 Loading device**, capable of applying the required load to the middle of the cover and of maintaining a constant load for a minimum of 15 min. The load shall be applied via a loading plate conforming to the requirements given in EN 124.

NOTE A loading device can comprise a hydraulic actuator; alternatively, the load can be applied using dead weight.

**5.3 Thermocouple**, capable of measuring temperature to an accuracy of  $\pm 5$  °C.

**5.4 Test assembly**, comprising at least the first 1 m of test assembly measured from, and including, the top assembly detail of the inspection chamber or manhole (see Figures 1 and 2).

Dimensions in metres

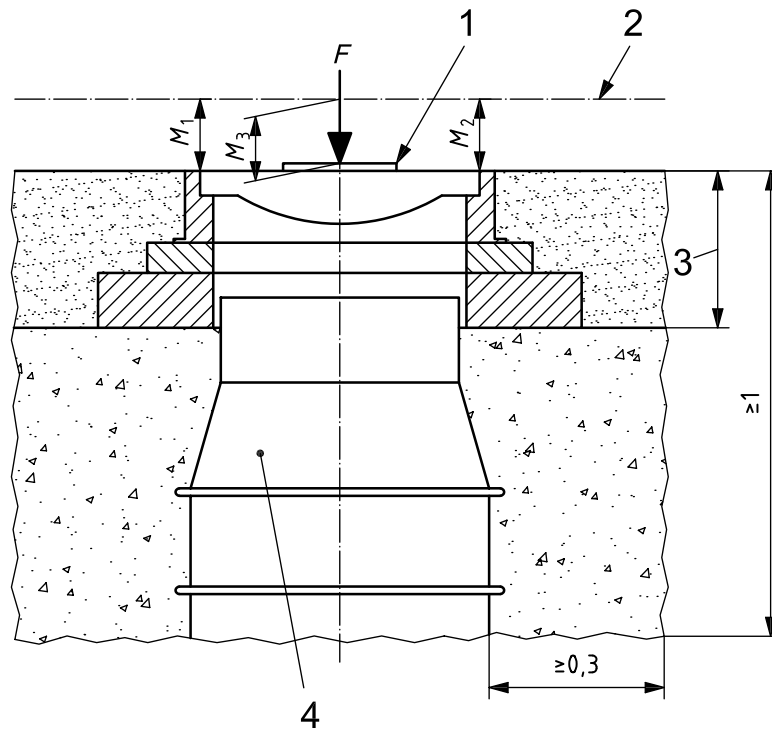

**Key**

- 1 loading plate, size in accordance with EN 124
- 2 reference line, datum
- 3 cover solution
- 4 top element of chamber or manhole
- $F$  test load
- $M_1, M_2$  and  $M_3$  dimensions for determining the displacement (see 8.2)

**Figure 1 — Test assembly**

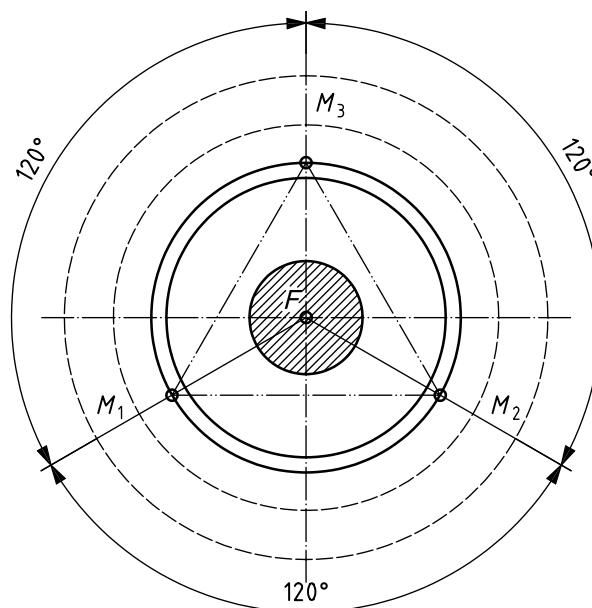

**Key**

- $F$  centre point of application of the test load
- $M_1, M_2$  and  $M_3$  points of measurement of displacements (see 8.2)

**Figure 2 — Position of measuring points**

## 6 Number of test pieces

Unless otherwise specified in the referring standard, the number of test pieces shall be one.

## 7 Conditioning and test temperatures

The test pieces shall not be tested for at least 24 h after manufacture.

The test shall be performed at ambient temperature between 5 °C and 25 °C. The test shall not be performed if the granular surround is at a temperature of less than 3 °C. The temperature of the granular surround shall be recorded.

## 8 Procedure

**8.1** Bury the test assembly (5.4) either in the soil box (5.1) or under field conditions using the test parameters given in Table 1, ensuring that there is at least 300 mm of specified granular surround conforming to Clause 9. Where the test assembly is to be buried in the field, excavate enough soil to accommodate at least the first metre of the riser shaft below the test assembly. Bury the thermo-couple in the granular surround at the top of the riser shaft, but below the other assembly components, at a distance of approximately 300 mm.

Where the inspection chamber or manhole incorporates a pavement as an integral part of the cover, apply the pavement as in real practice and bury under field conditions.

Where telescopic joints are supplied, install the support ring and covers in accordance with the manufacturer's product or installation description.

Measure and record at the specified points the distance between the top of the cover and a reference line (datum) which will not be affected by the load (see Figure 1).

**8.2** Apply the load using the loading device (5.2) within a period of 1 min to 5 min and maintain at the maximum value specified in Table 1 for a minimum of 15 min. Having applied the load re-measure and record the distances between the top of the cover and the datum.

**8.3** After removal of the load, visually inspect the test assembly inspecting for cracks or defects likely to impair performance.

## 9 Test parameters

Unless as otherwise specified in the referring system standard, the test parameters shall conform to Table 1.



Table 1 — Test parameters

Classification of inspection chamber or manhole <sup>a</sup>	Maximum load <sup>b</sup> kN	Soil group of granular surround <sup>c</sup>	Compaction of granular surround <sup>d</sup> %
Class A	5	3	≤ 95
Class B	50	2	> 95 and ≤ 98
Class D	100	1	> 98
Class E	150	1	> 98

<sup>a</sup> The classification of the application shall be in accordance with EN 124.

<sup>b</sup> The maximum load is not to be confused with the test load for covers in EN 124.

<sup>c</sup> The classification of soil group shall be in accordance with ENV 1046. The soil group shall be as specified, unless otherwise specified in the minimum required installation condition of the manufacturer, in which case, the manufacturer's requirements shall apply.

<sup>d</sup> Unless otherwise specified in the minimum required installation condition of the manufacturer, in which case, the manufacturer's requirements shall apply.

## 10 Test report

The test report shall include the following information:

- a) a reference to this International Standard, i.e. ISO 13266:2010, and the referring standard;
- b) a detailed identification of the inspection chamber or manhole components tested sufficient for factory process control requirements;
- c) the installation details used during the test and their relationship to the recommended details of the manufacturer;
- d) the test procedure used;
- e) the soil temperature;
- f) the maximum load;
- g) the measured displacement(s);
- h) the test duration time;
- i) after testing, any observed crack(s) and other defects likely to impair the performance of the inspection chamber or manhole;
- j) any factors that could have affected the result, such as any incidents or any operating details not specified in this International Standard;
- k) the date of test.

---

---

**ICS 23.040.20; 23.040.45; 91.140.80; 93.030**

Price based on 5 pages