

---

---

**Thermoplastics piping systems for non-  
pressure applications — Test method for  
resistance to elevated temperature  
cycling**

*Systèmes de canalisations thermoplastiques pour applications sans  
pression — Méthode d'essai de résistance à des cycles de température  
élevée*



**PDF disclaimer**

This PDF file may contain embedded typefaces. In accordance with Adobe's licensing policy, this file may be printed or viewed but shall not be edited unless the typefaces which are embedded are licensed to and installed on the computer performing the editing. In downloading this file, parties accept therein the responsibility of not infringing Adobe's licensing policy. The ISO Central Secretariat accepts no liability in this area.

Adobe is a trademark of Adobe Systems Incorporated.

Details of the software products used to create this PDF file can be found in the General Info relative to the file; the PDF-creation parameters were optimized for printing. Every care has been taken to ensure that the file is suitable for use by ISO member bodies. In the unlikely event that a problem relating to it is found, please inform the Central Secretariat at the address given below.



**COPYRIGHT PROTECTED DOCUMENT**

© ISO 2010

All rights reserved. Unless otherwise specified, no part of this publication may be reproduced or utilized in any form or by any means, electronic or mechanical, including photocopying and microfilm, without permission in writing from either ISO at the address below or ISO's member body in the country of the requester.

ISO copyright office  
Case postale 56 • CH-1211 Geneva 20  
Tel. + 41 22 749 01 11  
Fax + 41 22 749 09 47  
E-mail [copyright@iso.org](mailto:copyright@iso.org)  
Web [www.iso.org](http://www.iso.org)

Published in Switzerland

## Foreword

ISO (the International Organization for Standardization) is a worldwide federation of national standards bodies (ISO member bodies). The work of preparing International Standards is normally carried out through ISO technical committees. Each member body interested in a subject for which a technical committee has been established has the right to be represented on that committee. International organizations, governmental and non-governmental, in liaison with ISO, also take part in the work. ISO collaborates closely with the International Electrotechnical Commission (IEC) on all matters of electrotechnical standardization.

International Standards are drafted in accordance with the rules given in the ISO/IEC Directives, Part 2.

The main task of technical committees is to prepare International Standards. Draft International Standards adopted by the technical committees are circulated to the member bodies for voting. Publication as an International Standard requires approval by at least 75 % of the member bodies casting a vote.

Attention is drawn to the possibility that some of the elements of this document may be the subject of patent rights. ISO shall not be held responsible for identifying any or all such patent rights.

ISO 13257 was prepared by Technical Committee ISO/TC 138, *Plastics pipes, fittings and valves for the transport of fluids*, Subcommittee SC 1, *Plastics pipes and fittings for soil, waste and drainage (including land drainage)*.



# Thermoplastics piping systems for non-pressure applications — Test method for resistance to elevated temperature cycling

## 1 Scope

This International Standard specifies a method for testing the resistance of thermoplastics piping systems for soil and waste discharge inside buildings, application area “B”, or buried in the ground within the building structure, application areas “BD” or “UD”, to 1 500 cycles of elevated temperature cycling.

NOTE This method assesses leaktightness and resistance to sagging.

## 2 Normative references

The following referenced documents are indispensable for the application of this document. For dated references, only the edition cited applies. For undated references, the latest edition of the referenced document (including any amendments) applies.

ISO/TS 7024, *Plastics piping systems for soil and waste discharge (low and high temperature) inside buildings — Thermoplastics — Recommended practice for installation*

## 3 Terms and definitions, and symbols

### 3.1 Terms and definitions

For the purposes of this document, the following terms and definitions apply.

#### 3.1.1

##### nominal outside diameter

$d_n$

specified diameter assigned to a nominal size (DN/OD or DN/ID)

NOTE It is expressed in millimetres.

#### 3.1.2

##### expansion gap

$E$

distance between the bottom of a socket and the spigot of the inserted component allowing expansion of the system

NOTE Adapted from ISO/TS 7024:2005, definition 3.2.4.

#### 3.1.3

##### free length between fixed points

$L_F$

maximum permitted span between support centres in an above-ground installation

### 3.2 Symbols

For the purposes of this document, the symbols given in ISO/TS 7024 apply.

## 4 Principle

A test assembly of pipes and fittings is subjected to a given pattern of thermal cycling by using hot and cold water alternately for a given number of cycles during which the leaktightness of joints is verified by inspection and sagging of the pipe is checked against a given limit.

It is assumed that the following test parameter is set by the referring standard: the minimum value for the expansion gap,  $E$ , for a pipe or socket joint (see Clause 6).

## 5 Apparatus

**5.1 Thermometer or other temperature measuring device**, capable of checking conformity of the assembly inlet water temperature to the specified temperature limits (see 5.2, 5.3 and Clause 6).

It is recommended that the device be capable of recording and controlling the relevant temperature and time cycles (see Clause 7).

**5.2 Cold water source**, capable of supplying, every 4 min, the following quantities of water at  $(15 \pm 5)^\circ\text{C}$  (see 7.3):

- a) for Programme A,  $(30 \pm 0,5)$  l in  $(60 \pm 2)$  s;
- b) for Programme B,  $(15 \pm 0,5)$  l in  $(60 \pm 2)$  s.

**5.3 Hot water source**, capable of supplying, every 4 min, the following quantities of water at  $(93 \pm 2)^\circ\text{C}$  (see 7.3):

- a) for Programme A,  $(30 \pm 0,5)$  l in  $(60 \pm 2)$  s;
- b) for Programme B,  $(15 \pm 0,5)$  l in  $(60 \pm 2)$  s.

**5.4 Plugs or other closures**, to seal, temporarily, the water outlet (see 7.1 and 7.4).

**5.5 Device**, capable of measuring pipe sagging as shown in Figure 1, 2 and 3, as applicable, to an accuracy of 0,1 mm.

**5.6 Supporting brackets**, as appropriate, comprising anchor brackets (fixed points) capable of restraining piping components and guide brackets capable of supporting piping components without inhibiting longitudinal movement (see Clause 6 and Figures 1, 2 and 3).

## 6 Test assembly

The test assembly shall comprise a vertical stack of pipes with fittings and two near-horizontal pipe assemblies with fittings. The assembly shall depend on the purposes for which the components are intended as follows:

- a) for components intended for use in systems inside buildings (application area “B” only);
- b) as a test assembly supplementary to a) for components intended for use in systems buried in the ground within the building structure (application areas “BD” and “UD”).

Typical test assemblies are shown in Figure 1 (application area “B” only), Figure 2 (application areas “BD” and “UD”) and Figure 3 (application area “B” for nominal diameters,  $d_n$ , smaller than 40 mm), where the positions and the types of the joint or fitting are indicative only. For application areas “BD” and “UD”, the components shall be assembled such that the weld lines are in the water flow.

The position and the type of joint(s) to be used shall be as appropriate for the system under test (e.g. cemented joint, welded joints, lip seal joints). The assembly of the joint(s) shall be carried out in accordance with the manufacturer's instructions and any applicable recommended practice for installation, e.g. to avoid undue stress in the test assembly. The symbols used to specify or report on a test assembly shall conform to ISO/TS 7024.

Installation of the test assembly shall be carried out on a firm wall or frame, using both fixed and guide brackets, with no other support of the test assembly.

Anchor brackets shall be located directly on, below or behind the sockets of each pipe length, except for

- c) the first pipe in the near-horizontal line from the inlet, where a possible sagging is to be measured (see Figure 1, Figure 2 or Figure 3, as applicable), and
- d) the pipe with nominal outside diameter,  $d_n$ , smaller than 40 mm, where the distance between the brackets shall always be 400 mm.

Guide brackets for near-horizontal assemblies shall be placed not less than  $10d_n$  apart.

Room for expansion of pipes shall be provided for all spigot ends of pipes, but not for the spigot ends of fittings, and shall be not less than the minimum value for the gap,  $E$ , as specified by the referring standard.

The entry of hot water into the test assembly shall be direct, i.e. there shall be no heat-absorbing intermediate pieces.

## 7 Procedure

**7.1** Fill the test assembly with water, at a temperature not exceeding 20 °C, to a head of 500 mm above the highest point of the centreline of the upper lateral pipe.

Leave for a minimum period of 15 min and then visually check for, and record, any leaks.



**7.2** If any leaks are observed, check and rectify the joint assembly (see Clause 6) and repeat the watertightness test given in 7.1.

If any further leaks are observed, stop the test and report the observations in accordance with Clause 8.

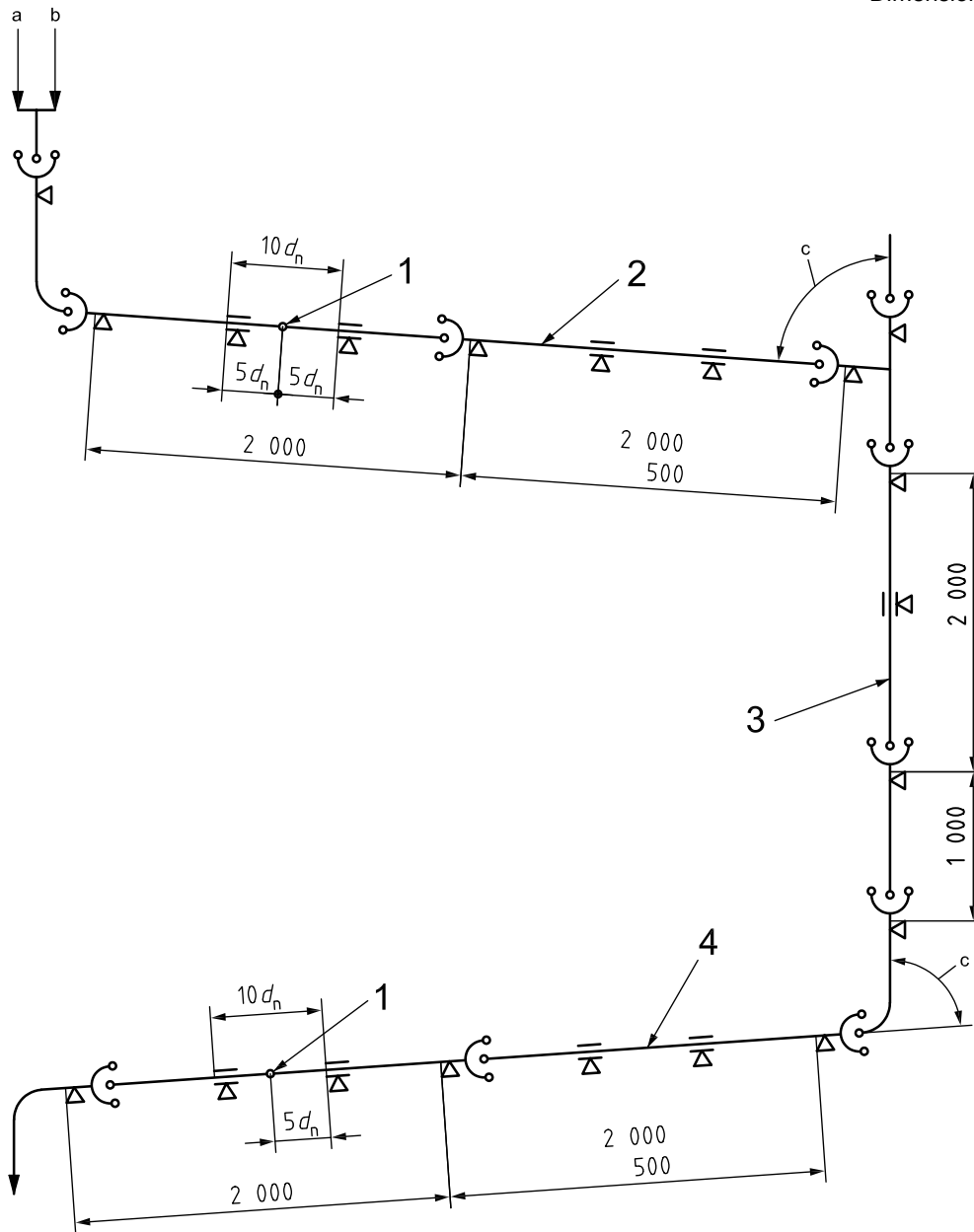
If no further leaks are observed, proceed in accordance with 7.3 to 7.5.



**Key**

-  ring seal socket, illustrated in accordance with ISO/TS 7024
-  fixed points, illustrated in accordance with ISO/TS 7024
-  guide brackets, illustrated in accordance with ISO/TS 7024

- 1 sagging measuring point
- 2 pipe  $G_0$ :  $d_n = 40$  mm or  $d_n = 50$  mm
- 3 pipe  $G_1$ :  $75 \text{ mm} \leq d_n \leq 160$  mm
- 4 pipe  $G_2$ :  $75 \text{ mm} \leq d_n \leq 160$  mm
- a Hot water.
- b Cold water.
- c Angle  $\alpha$ :  $85^\circ \leq \alpha \leq 89^\circ$ .

Other types of joints may be used as appropriate.

NOTE In this test assembly, joints with elastomeric ring seals are given as examples.



**Figure 1 — Typical test assembly for elevated temperature cycling test (1 500 cycles) for piping systems inside buildings (application area “B” only)**

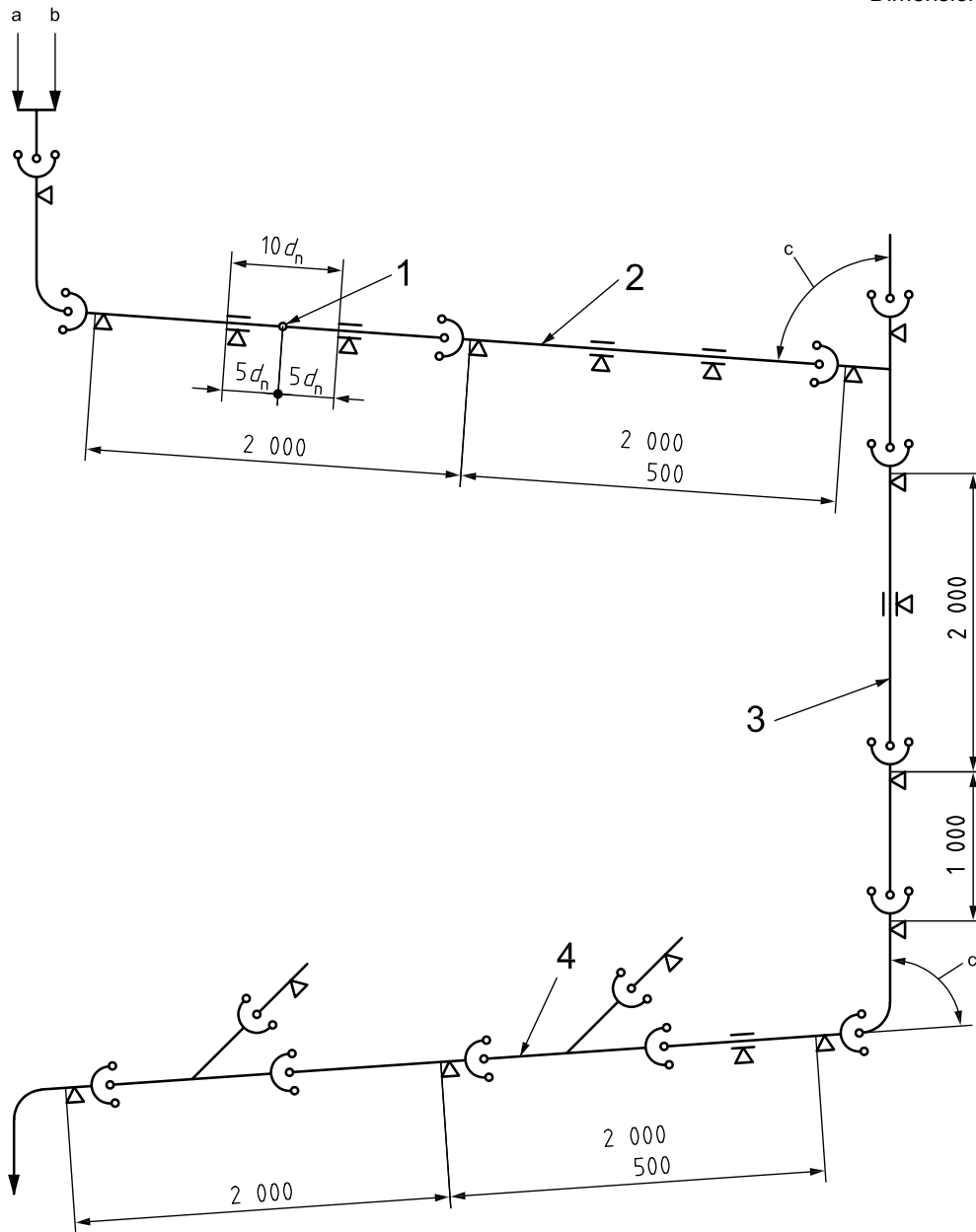

Dimensions in millimetres



**Key**

-  ring seal socket, illustrated in accordance with ISO/TS 7024
-  fixed points, illustrated in accordance with ISO/TS 7024
-  guide brackets, illustrated in accordance with ISO/TS 7024

- 1 sagging measuring point
- 2 pipe  $G_0$ :  $d_n = 40$  mm or  $d_n = 50$  mm
- 3 pipe  $G_1$ :  $75 \text{ mm} \leq d_n \leq 160$  mm
- 4 pipe  $G_2$ :  $75 \text{ mm} \leq d_n \leq 200$  mm

- a Hot water.
- b Cold water.
- c Angle  $\alpha$ :  $85^\circ \leq \alpha \leq 89^\circ$ .

Other types of joints may be used as appropriate.

NOTE In this test assembly, joints with elastomeric ring seals are given as examples.

**Figure 2 — Typical test assembly for elevated temperature cycling test (1 500 cycles) for piping systems buried in the ground within the building structure (application area “BD” and “UD”)**

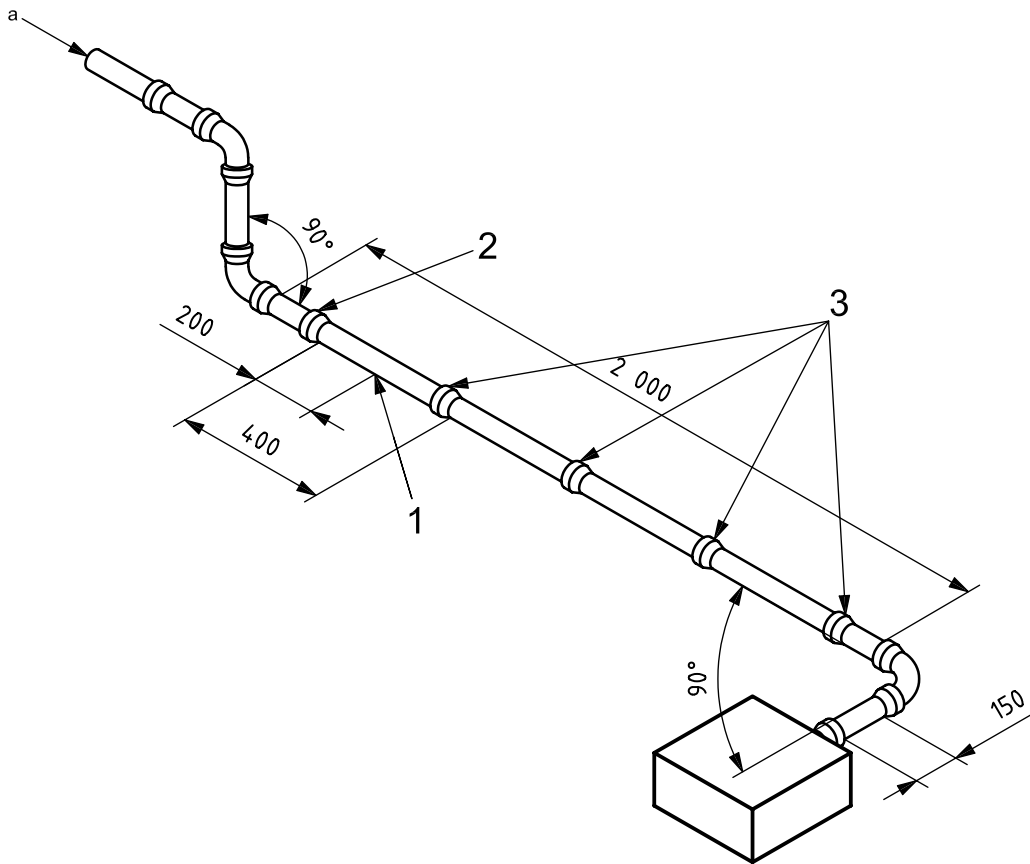

**Key**

- 1 sagging measuring point
- 2 fixed bracket
- 3 guide bracket
- a Water inlet.

**Figure 3 — Typical test assembly for elevated temperature cycling test (1 500 cycles) for piping systems with components with nominal outside diameter,  $d_n$ , smaller than 40 mm for use inside building (application area “B”)**

**7.3** While monitoring the test assembly for any signs of leaks or changes of appearance, subject the test assembly to the passage of hot and cold water for 1 500 cycles of either Programme A or Programme B, as applicable, as follows. In case of dispute, maintain the temperature at  $(20 \pm 5) \text{ }^\circ\text{C}$ .

Programme A (nominal flow rate 30 l/min), for components with nominal outside diameter,  $d_n$ , equal to or greater than 40 mm:

- a)  $(30 \pm 0,5)$  l of water at  $(93 \pm 2) \text{ }^\circ\text{C}$ , measured at the point of entry, over a period of  $(60 \pm 2)$  s;
- b) rest and drain period of  $(60 \pm 2)$  s;
- c)  $(30 \pm 0,5)$  l of water at  $(15 \pm 5) \text{ }^\circ\text{C}$ , measured at the point of entry, over a period of  $(60 \pm 2)$  s;
- d) rest and drain period of  $(60 \pm 2)$  s;
- e) return to a).

Programme B (nominal flow rate 15 l/min), for components with nominal outside diameter,  $d_n$ , smaller than 40 mm:

- f)  $(15 \pm 0,5)$  l of water at  $(93 \pm 2)$  °C, measured at the point of entry, over a period of  $(60 \pm 2)$  s;
- g) rest and drain period of  $(60 \pm 2)$  s;
- h)  $(15 \pm 0,5)$  l of water at  $(15 \pm 5)$  °C, measured at the point of entry, over a period of  $(60 \pm 2)$  s;
- i) rest and drain period of  $(60 \pm 2)$  s;
- j) return to f).

**7.4** On completion of the 1 500 cycles, fill the test assembly with water, at a temperature not exceeding 20 °C, to a head of 500 mm above the highest point of the centreline of the upper lateral pipe.

Leave for a minimum period of 15 min and then visually check for, and record, any leaks.

**7.5** Check for any sagging at the midpoint between the guide brackets separated by  $10d_n$ , as shown in Figures 1 and 2, or the brackets separated by 400 mm, as shown in Figure 3, as applicable. Record any incidence of sagging greater than  $0,1d_n$ , in millimetres.

**7.6** Inspect the test piece components for any changes in appearance, including any visible opening of weld lines, and record them.

## 8 Test report

The test report shall include the following information:

- a) a reference to this International Standard, i.e. ISO 13257:2010, and to the referring standard;
- b) the complete identification of the components (e.g. fittings, pipes, assemblies, comprising the joints under test) and their application area code, "B" or "BD" and "UD";
- c) the test temperature, in degrees Celsius;
- d) any observations of leakage before the cycling test (see 7.2);
- e) any relevant observations during the cycling test, e.g. any signs of leakage or deformation (see 7.3);
- f) the results of the watertightness test after the cycling test (see 7.4);
- g) any sagging found at the end of the cycling test (see 7.5);
- h) any change observed in the appearance of the test pieces during the test or immediately afterwards, including any visible opening of weld lines (see 7.3 and 7.6);
- i) any factor that could have affected the results, such as any incident or any operating detail not specified in this International Standard;
- j) the date of the test.

---

---

**ICS 23.040.20 91.140.80**

Price based on 7 pages