

First edition
2012-02-15

**Road vehicles — LED lamp characteristics
for bulb compatible failure detection —**

**Part 1:
LED lamps used as direction indicators**

*Véhicules routiers — Caractéristiques des lampes LED pour détection
de défaut compatible avec l'ampoule —*

Partie 1: Lampes LED utilisées comme feux indicateurs de direction



Reference number
ISO 13207-1:2012(E)

© ISO 2012



COPYRIGHT PROTECTED DOCUMENT

© ISO 2012

All rights reserved. Unless otherwise specified, no part of this publication may be reproduced or utilized in any form or by any means, electronic or mechanical, including photocopying and microfilm, without permission in writing from either ISO at the address below or ISO's member body in the country of the requester.

ISO copyright office
Case postale 56 • CH-1211 Geneva 20
Tel. + 41 22 749 01 11
Fax + 41 22 749 09 47
E-mail copyright@iso.org
Web www.iso.org

Published in Switzerland

Foreword

ISO (the International Organization for Standardization) is a worldwide federation of national standards bodies (ISO member bodies). The work of preparing International Standards is normally carried out through ISO technical committees. Each member body interested in a subject for which a technical committee has been established has the right to be represented on that committee. International organizations, governmental and non-governmental, in liaison with ISO, also take part in the work. ISO collaborates closely with the International Electrotechnical Commission (IEC) on all matters of electrotechnical standardization.

International Standards are drafted in accordance with the rules given in the ISO/IEC Directives, Part 2.

The main task of technical committees is to prepare International Standards. Draft International Standards adopted by the technical committees are circulated to the member bodies for voting. Publication as an International Standard requires approval by at least 75 % of the member bodies casting a vote.

Attention is drawn to the possibility that some of the elements of this document may be the subject of patent rights. ISO shall not be held responsible for identifying any or all such patent rights.

ISO 13207-1 was prepared by Technical Committee ISO/TC 22, *Road vehicles*, Subcommittee SC 3, *Electrical and electronic equipment*.

ISO 13207 consists of the following parts, under the general title *Road vehicles — LED lamp characteristics for bulb compatible failure detection*:

— *Part 1: LED lamps used as direction indicators*

Road vehicles — LED lamp characteristics for bulb compatible failure detection —

Part 1: LED lamps used as direction indicators

1 Scope

This part of ISO 13207 specifies the characteristics of LED (Light Emitting Diode) lamps used as direction indicators when optionally monitored. It applies primarily to those lamps which are installed on 24V truck/trailer combinations. It will enable lamp-failure detection of LED lamps on the drawn vehicle to be compatible with that for bulbs when analysed by the towing unit.

2 Terminals

The connection between the towing vehicle and the towed vehicle should be either as described in ISO 1185 and ISO 3731 or as described in ISO 12098. Towing vehicles should be equipped with electronic control units (ECUs), which drive the trailer direction indicator lamps as described in ISO 4082.

3 Functional description

3.1 Principle

Lamp-failure monitoring electronics are required for mandatory mounted direction-indicator functions. For this purpose, the LED direction-indicator function generates a current impulse at a certain time; this current impulse corresponds in terms of amount with the current of a conventional bulb lamp. If the LED direction indicator fails (in relation to the legal requirement of the photometric output), this pulse is not generated. An ECU or intelligent flasher interprets whether the LED direction indicator fails on the basis of this pulse. The result should be used to inform the driver accordingly.

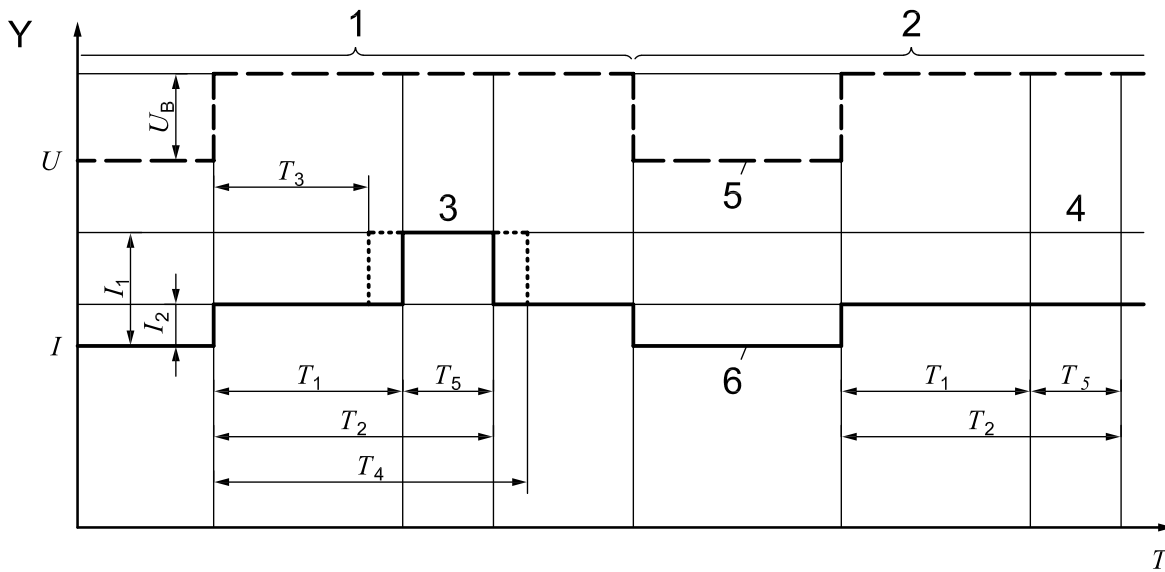

Key

- 1 first process
- 2 second process
- 3 non-failure
- 4 failure
- 5 voltage: power supply of direction indicator during two flashing processes
- 6 current of LED direction indicator during two flashing processes, the first with, and second without, current control pulse added
- I* current
- I*₂ nominal LED lamp current
- I*₁ *I*₂ + control pulse current
- T* time
- T*₁ starting point of the designated pulse time frame
- T*₂ end of the designated pulse time frame
- T*₃ earliest start point for the control pulse
- T*₄ latest end point for the control pulse
- T*₅ time frame within which the designated control pulse should be detected by the monitoring circuit of the control unit
- U* voltage
- U*_B operational voltage
- Y* voltage, *U*, in volts; current, *I*, in amperes

Figure 1 — Profile diagram 1

The functional description of the profiles is shown in Figure 1. If a current as described in Figure 3 is detected in time frame *T*₅ in the first process, the condition of the lamp is recognized as a “non-failure”.

3.2 Parallel operation of LED and bulb lamps

The number of functioning direction indicators can be determined on the basis of the amplitude of the pulse when switching on several direction indicators in parallel. In the case of a lamp with mixed LED/21 W bulb light sources, the amplitude of the pulse also provides information about the number of functioning direction indicators connected.

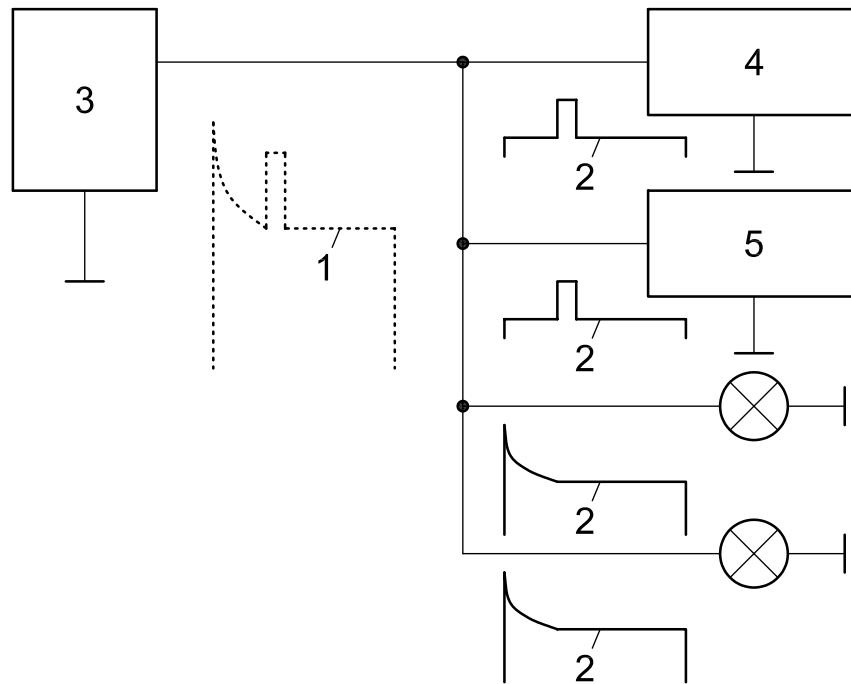

Key

- 1 total current pass
- 2 current pass in the individual units
- 3 control unit
- 4, 5 direction indicator with pulse generation

Figure 2 — Bulb lamps

Figure 2 shows 2 × 21 W bulb lamps and 2 × LEDs in a direction indicator, all other combinations are possible. For reasons of clarity, only one side of the vehicle direction indicators is illustrated.

4 Dimensions

4.1 Pulse current

The pulse current is directly related to the voltage supply as shown in Figure 3, here for the 24 V/21 W system.

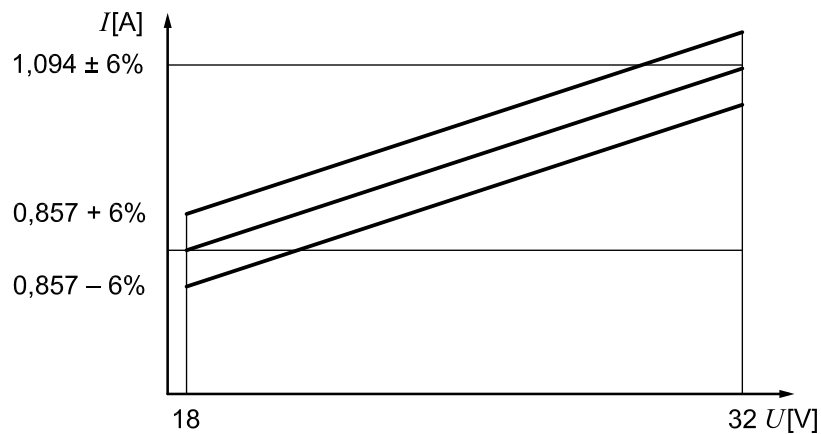

Figure 3 — Relation between pulse current (I) and voltage supply (U)

The circuit-load characteristic of the pulse shall be equivalent to that of a 21 W filament lamp, including tolerances [DIN 72601 (all parts) and ECE-R37].

4.2 Pulse timing

The pulse timing dimensions are given in Table 1.

Table 1 — Pulse timing

Description	Condition	Value	Unit
$T_5 = T_2 - T_1$	Designated time frame for the pulse for the non-failure condition	20	ms
T_1	Designated switch-on point for the non-failure pulse through the lamp	100	ms
T_2	Designated switch-off point for the non-failure pulse through the lamp	120	ms
T_3	Earliest switch-on point for the non-failure pulse through the lamp	95	ms
T_4	Latest switch-off point for the non-failure pulse through the lamp	125	ms

5 Other dimensions

The lamp current I_2 should be below 30 mA for the failure condition and above 60 mA (at 24 V) for the non-failure condition to enable usage of plain constant-measurement circuits with two levels (below 30 mA means non-functional LED-lamp). Other details, not specified, are left to the manufacturer's choice.

6 Further details

It is not possible to check whether the system is functioning before the first flashing process. The system should function under the environmental and test conditions specified in ISO 16750 (all parts). The total number of LED direction indicators and conventional lamps in one measuring circuit is limited to 4. The operating voltage range for the pulse control shall be between 18 V up to 32 V.

7 Trailer detection

7.1 General

To facilitate uniform trailer detection by the towing unit, a resistance load of 820 Ω for standardization of the detection function for direction indicators is specified.

7.2 Method for powerless trailer detection

In the input circuit of a LED lamp, a resistor $R = 820 \Omega$ is connected to ground via an electronic power switch (S_1); see Figure 4. The power switch is closed when the input voltage (U_1) is between 0 and 10 V. When the voltage increases to values > 10 V, the power switch is turned to open and disconnects the resistor from the input circuit.

The advantage of this method is that the power consumption of the resistor can be determined at 250 mW.

For a powerless trailer detection, an ECU connects a voltage U , e.g. over a pull-up resistor, to the LED lamp. If a trailer is present, the voltage is low; if a trailer is not present, the voltage is high.

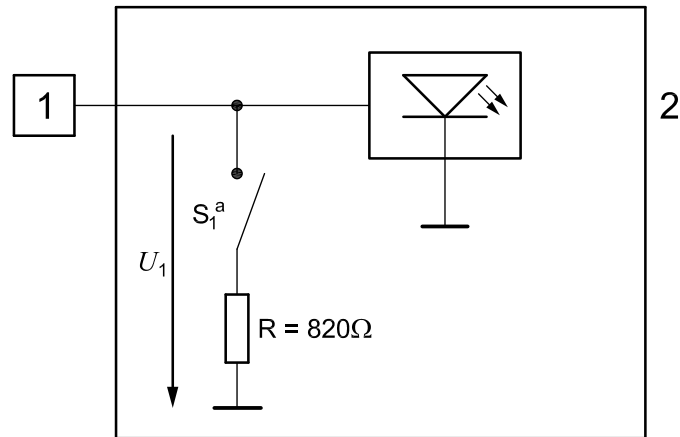
**Key**

- 1 ECU
- 2 LED-Lamp
- R resistor
- S_1 electronic power switch
- U_1 input voltage

- ^a S_1 is closed when U_1 is between 0 and 10 V; S_1 is open when $U_1 > 10$ V.

Figure 4 — Connection scheme

Bibliography

- [1] ISO 4082, *Road vehicles — Motor vehicles — Flasher units*
- [2] ISO 1185, *Road vehicles — Connectors for the electrical connection of towing and towed vehicles — 7-pole connector type 24 N (normal) for vehicles with 24 V nominal supply voltage*
- [3] ISO 3731, *Road vehicles — Connectors for the electrical connection of towing and towed vehicles — 7-pole connector type 24 S (supplementary) for vehicles with 24 V nominal supply voltage*
- [4] ISO 12098, *Road vehicles — Connectors for the electrical connection of towing and towed vehicles — 15-pole connector for vehicles with 24 V nominal supply voltage*
- [5] ISO 16750 (all parts), *Road vehicles — Environmental conditions and testing for electrical and electronic equipment*
- [6] DIN 72601 (all parts), *Lamps for road vehicles*
- [7] ECE-R37, *Filament lamps of power-driven vehicles and their trailers*

Copyright International Organization for Standardization

ICS 43.040.20; 43.040.30

Price based on 6 pages