**Water quality — Radium-226 —
Part 2:
Test method using emanometry**

Qualité de l'eau — Radium 226 —

Partie 2: Méthode d'essai par émanométrie



Reference number
ISO 13165-2:2014(E)

© ISO 2014



COPYRIGHT PROTECTED DOCUMENT

© ISO 2014

All rights reserved. Unless otherwise specified, no part of this publication may be reproduced or utilized otherwise in any form or by any means, electronic or mechanical, including photocopying, or posting on the internet or an intranet, without prior written permission. Permission can be requested from either ISO at the address below or ISO's member body in the country of the requester.

ISO copyright office
Case postale 56 • CH-1211 Geneva 20
Tel. + 41 22 749 01 11
Fax + 41 22 749 09 47
E-mail copyright@iso.org
Web www.iso.org

Published in Switzerland

Contents

Page

Foreword	iv
Introduction	v
1 Scope	1
2 Normative references	1
3 Terms, definitions and symbols	1
3.1 Terms and definitions.....	1
3.2 Symbols.....	2
4 Principle	2
5 Reagents and equipment	3
5.1 Reagents.....	3
5.2 Equipment.....	3
6 Sampling and storage	4
6.1 Sampling.....	4
6.2 Sample storage.....	4
7 Procedures	4
7.1 Sample preparation.....	4
7.2 Measurement conditions.....	5
7.3 Counting procedure.....	5
8 Quality assurance and quality control programme	5
8.1 General.....	5
8.2 Influence parameters.....	5
8.3 Instrument verification and calibration.....	6
8.4 Method verification.....	6
8.5 Demonstration of analyst capability.....	6
9 Expression of results	6
9.1 Activity concentration of water-soluble ^{226}Ra	6
9.2 Standard uncertainty of activity concentration.....	7
9.3 Limits of the confidence interval.....	8
9.4 Example.....	8
10 Test report	8
Annex A (informative) Decay chains of uranium-238 and thorium-232	10
Annex B (informative) Bubbler	12
Annex C (informative) Glass scintillation cell	14
Bibliography	15

Foreword

ISO (the International Organization for Standardization) is a worldwide federation of national standards bodies (ISO member bodies). The work of preparing International Standards is normally carried out through ISO technical committees. Each member body interested in a subject for which a technical committee has been established has the right to be represented on that committee. International organizations, governmental and non-governmental, in liaison with ISO, also take part in the work. ISO collaborates closely with the International Electrotechnical Commission (IEC) on all matters of electrotechnical standardization.

The procedures used to develop this document and those intended for its further maintenance are described in the ISO/IEC Directives, Part 1. In particular the different approval criteria needed for the different types of ISO documents should be noted. This document was drafted in accordance with the editorial rules of the ISO/IEC Directives, Part 2 (see www.iso.org/directives).

Attention is drawn to the possibility that some of the elements of this document may be the subject of patent rights. ISO shall not be held responsible for identifying any or all such patent rights. Details of any patent rights identified during the development of the document will be in the Introduction and/or on the ISO list of patent declarations received (see www.iso.org/patents).

Any trade name used in this document is information given for the convenience of users and does not constitute an endorsement.

For an explanation on the meaning of ISO specific terms and expressions related to conformity assessment, as well as information about ISO's adherence to the WTO principles in the Technical Barriers to Trade (TBT) see the following URL: [Foreword - Supplementary information](#)

The committee responsible for this document is ISO/TC 147, *Water quality*, Subcommittee SC 3, *Radioactivity measurements*.

ISO 13165 consists of the following parts, under the general title *Water quality — Radium-226*:

- *Part 1: Test method using liquid scintillation counting*
- *Part 2: Test method using emanometry*

The following parts are under preparation:

- *Part 3: Test method using coprecipitation and gamma spectrometry*

Introduction

Radioactivity from several naturally occurring and human-made sources is present throughout the environment. Thus, water bodies (surface waters, ground waters, sea waters) can contain radionuclides of natural and human-made origins:

Natural radionuclides, including potassium-40, and those of the thorium and uranium decay series, in particular radium-226, radium-228, uranium-234, uranium-238, and lead-210, can be found in water for natural reasons (e.g. desorption from the soil and wash-off by rain water) or releases from technological processes involving naturally occurring radioactive materials (e.g. the mining and processing of mineral sands or phosphate fertilizer production and use).

Human-made radionuclides such as transuranium elements (americium, plutonium, neptunium, curium), tritium, carbon-14, strontium-90, and some gamma emitters radionuclides can also be found in natural waters as they can be authorized to be routinely released into the environment in small quantities in the effluent discharge from nuclear fuel cycle facilities and following their use in unsealed form in medicine or industry. They are also found in the water due to the past fallout of the explosion in the atmosphere of nuclear devices and those following the Chernobyl and Fukushima accidents.

Drinking water can thus contain radionuclides at activity concentration which could present a risk to human health. In order to assess the quality of drinking water (including mineral waters and spring waters) with respect to its radionuclide content and to provide guidance on reducing health risks by taking measures to decrease radionuclide activity concentrations, water resources (groundwater, river, lake, sea, etc.) and drinking water are monitored for their radioactivity content as recommended by the World Health Organization (WHO).

The need of a standard on a test method of radium-226 activity concentrations in water samples is justified for test laboratories carrying out these measurements, required sometimes by national authorities, as they may have to obtain a specific accreditation for radionuclide measurement in drinking water samples.

Radium-226 activity concentration can vary widely according to local geological and climatic characteristics and ranges from 0,001 Bq l⁻¹ in surface waters up to 50 Bq l⁻¹ in natural groundwaters. The guidance level for radium-226 in drinking water as recommended by WHO is 1 Bq l⁻¹ (see Reference [11]).

NOTE The guidance level is the activity concentration (rounded to the nearest order of magnitude) with an intake of 2 l·d⁻¹ of drinking water for 1 year that results in an effective dose of 0,1 mSv·y⁻¹ for members of the public, an effective dose that represents a very low level of risk that is not expected to give rise to any detectable adverse health effect.

This International Standard is one of a series on determination of the activity concentration of radionuclides in water samples.

Water quality — Radium-226 —

Part 2: Test method using emanometry

WARNING — Persons using this document should be familiar with normal laboratory practice. This document does not purport to address all of the safety problems, if any, associated with its use. It is the responsibility of the user to establish appropriate safety and health practices and to ensure compliance with any national regulatory conditions.

IMPORTANT — It is absolutely essential that tests conducted in accordance with this document be carried out by suitably qualified staff.

1 Scope

This part of ISO 13165 specifies the determination of radium-226 (^{226}Ra) activity concentration in all types of water by emanometry.

The method specified is suitable for the determination of the soluble, suspended, and total ^{226}Ra activity concentration in all types of water with soluble ^{226}Ra activity concentrations greater than $0,02 \text{ Bq l}^{-1}$.

In water containing high activity concentrations of ^{228}Th , interference from ^{220}Rn decay products can lead to overestimation of measured levels (see [Figure A.2](#)).

2 Normative references

The following documents, in whole or in part, are normatively referenced in this document and are indispensable for its application. For dated references, only the edition cited applies. For undated references, the latest edition of the referenced document (including any amendments) applies.

ISO 5667-3, *Water quality — Sampling — Part 3: Preservation and handling of water samples*

ISO/IEC 17025, *General requirements for the competence of testing and calibration laboratories*

ISO 80000-10, *Quantities and units — Part 10: Atomic and nuclear physics*

3 Terms, definitions and symbols

3.1 Terms and definitions

For the purposes of this document, the terms and definitions in ISO 80000-10 and the following apply.

3.1.1 reference measurement standard

measurement standard designated for the calibration of other measurement standards for quantities of a given kind in a given organization or at a given location

3.1.2 working measurement standard

measurement standard that is used routinely to calibrate or verify measuring instruments or measuring systems

Note 1 to entry: A working measurement standard can be used as a solution of known activity concentration obtained by precise dilution or dissolution of a reference standard.

3.2 Symbols

For the purposes of this document, the symbols in ISO 80000-10 and the following apply.

c_A	^{226}Ra activity concentration in water, in becquerel per litre
c_A^*	decision threshold, in becquerel per litre
$c_A^\#$	detection limit, in becquerel per litre
$c_A^\triangleleft, c_A^\triangleright$	lower and upper limits of the confidence interval, in becquerel per litre
f_a	correction factor for ingrowth of ^{222}Rn in the bubbler, dimensionless
f_d	correction factor for the decay of ^{222}Rn in the detection volume, dimensionless
n	number of counting cycle
n_α	number of alpha-emitters present in the cell per becquerel of radon after a waiting time period between the filling time and the counting time of the cell (n_α is approximately 3 at a waiting time of 3 h for 1 Bq of radon)
N_0	number of background counts
N	number of gross counts
t_c	counting time (common to N, N_0), in seconds
t_i	time of the different steps of the measurement procedure, $i = 0, 1$ and 2
U	expanded uncertainty calculated by $U = ku(c_A)$ with $k = 2$
$u(c_A)$	standard uncertainty associated with the measurement result
V	volume of the test sample, in litre
ε	total efficiency including degassing efficiency and counting efficiency of the system for a count carried out with a radioactive equilibrium between ^{222}Rn and its short-lived decay products, in pulses per second per becquerel
λ	decay constant of the ^{222}Rn , per second

4 Principle

This test method is based on the emanation and scintillation counting of ^{222}Rn , a gaseous daughter product of ^{226}Ra , from a solution (see Reference [6]).

The measurement of ^{226}Ra activity concentration in water is carried out following two separate steps, the sample preparation followed by the measurement of the test sample.

Preparation consists of:

- dissolution when total or particulate radium is to be assayed;
- filtration when soluble radium is to be measured.

It is followed by pre-concentration, if necessary, and an accumulation of decay products without an initial separation.

After filtration and acidification, the test sample is placed in a bubbler (see [Figure B.1](#)) and stored for ingrowth of ^{222}Rn .

After a suitable ingrowth period, the radon gas is removed from the solution by purging with the radon-free gas and transferring it to a scintillation cell, whose internal surface is coated with silver-activated zinc sulfide, $\text{ZnS}(\text{Ag})$ (see [Figure C.1](#)) (see Reference [8]).

The alpha-particles produced by the decay of ^{222}Rn and its short-lived decay products (^{218}Po , ^{214}Po) transfer their energy as they pass through the scintillation medium. As they return to their ground state, the excitation electrons in the scintillation medium emit photons from the $\text{ZnS}(\text{Ag})$ coating that can be detected by a photomultiplier (PMT). The photomultiplier converts the photons into electrical pulses that are then counted. The pulse count is directly proportional to the activity concentration of radon and its decay products present in the scintillation cell.

The soluble ^{226}Ra activity concentration is calculated, taking into account the known steady state between ^{226}Ra and ^{222}Rn after transferring ^{222}Rn into a scintillation cell.

Given its high power of emanation, radon can also escape from particles suspended in water. In the case of the analysis of raw water, it is therefore advisable to dissolve the particulate fraction (see Reference [7]).

5 Reagents and equipment

5.1 Reagents

Unless otherwise stated, use only reagents of recognized analytical grade and distilled or demineralized water or water of equivalent purity and no undesirable radioactivity.

5.1.1 Concentrated nitric acid solution, HNO_3 .

5.1.2 Dilute nitric acid solution, less than or equal to 100 g l^{-1} , with no alpha-radioactivity.

5.1.3 Reference solution of ^{226}Ra .

5.1.4 Cellulose ester filter, $0,45 \mu\text{m}$ porosity.

5.1.5 Hydrochloric acid solution, if the particulate fraction of ^{226}Ra requires dissolution.

5.2 Equipment

Usual laboratory equipment and, in particular, the following.

5.2.1 Hotplates.

5.2.2 Needles, length of approximately 30 mm, diameter of approximately 1,5 mm.

5.2.3 Bubblers, minimum volume of 125 ml with two (poly)tetrafluoroethylene needle valves (see [Figure B.1](#)).

5.2.4 Specialized solid-state scintillation detection set, equipped with a photomultiplier.

5.2.5 Manometer, to measure pressure.

5.2.6 Flat-bottomed glass scintillation cell, volume of 250 ml to 500 ml.

The internal surface of the cell, apart from the bottom, is coated with silver-activated zinc sulfide, $\text{ZnS}(\text{Ag})$. The external surface is coated with a light-excluding material except on its flat bottom, which forms the measurement window (see [Figure C.1](#)).

5.2.7 Vacuum pump, to obtain a pressure reduction of about 300 Pa.

5.2.8 Constant alpha-emitting radioactive source, e.g. ^{239}Pu .

6 Sampling and storage

6.1 Sampling

The sampling conditions shall comply with ISO 5667-3.

It is important that the laboratory receive a sample that has not been damaged or modified during transport or storage.

6.2 Sample storage

If required, the water sample (from 0,5 l to 1,0 l) shall be stored according to ISO 5667-3.

When pre-concentration is desired, acidify the sample to between pH 1 and pH 3 with HNO_3 . When necessary, carry out filtration immediately on collection and before acidification.

Acidification of the water sample minimizes the loss of radioactive material from the solution by adsorption. If filtration of the sample is required, perform the acidification afterwards; otherwise, radioactive material already adsorbed on to the particulate material can be desorbed.

7 Procedures

7.1 Sample preparation

When the soluble radium and particulate radium have to be measured separately, the water sample is filtrated using a 0,45 μm filter.

The initial sample volume is generally 0,5 l or 1,0 l.

For 0,5 l, add 5 ml of the concentrated nitric acid solution (5.1.1) to the sample (raw or filtrated). Concentrate the solution by evaporation, without boiling, down to a volume of about 25 ml. Alternative methods can be used to concentrate the sample, such as sulfate co-precipitation followed by dissolution using EDTA. In this case, if a complete recovery of radium-226 is not guaranteed, the chemical yield should be determined and corrected for.

NOTE The particulate fraction of ^{226}Ra is dissolved by mineralization using hydrochloric or nitric acid.

After cooling, pour the solution into a bubbler, rinse several times with the dilute nitric acid solution (5.1.2), rubbing the inner walls of the container. The rinsing solutions are transferred successively to the bubbler. The total volume shall not exceed 50 ml.

Rn-222 initially dissolved in the water is eliminated by a first bubbling step:

- open the valves;
- sparge the radon-free gas through the water sample using a fine air bubble for at least 20 min;
- close the valves.

Note the date and time corresponding to t_0 .

Let ^{222}Rn accumulate in the bubbler for at least 5 d (at least 2 d if results are urgently needed and provided the activity concentration is at least 2 Bq l^{-1}).

The formation of precipitates in the bubbler during the ^{222}Rn ingrowth period demonstrates that ^{222}Rn recovery can be impaired and that the sample preparation procedure needs the addition of a filtration step.

7.2 Measurement conditions

Due to the degassing process, only gaseous alpha-emitting radionuclides, ^{219}Rn (actinon) and ^{220}Rn (thoron), can interfere. Interference from these radionuclides would be expected to be very rare in water not contaminated by such industrial wastes as uranium mill effluents. As the half-lives of these nuclides are short, less than 1 min, only their alpha-emitting decay products can interfere.

7.3 Counting procedure

In parallel, prepare the scintillation cell as follows:

- produce a vacuum of a few kPa with the pump to remove the air of the scintillation cell;
- fill the cell with radon-free gas up to atmospheric pressure;
- measure the cell background by counting the electrical pulses from the PMT for a suitable duration equal to the sample counting time;
- produce a vacuum of a few kPa with the pump to remove the air of the scintillation cell again.

Connect the bubbler (valve 2) to the scintillation cell. To transfer the radon, open valve 1 and when no more bubbles are produced, open valve 2. The bubbling shall be very slow (fine bubbles). When the pressures are balanced, the transfer is completed (about 20 min).

Note the date and time corresponding to t_1 .

Close the valves. Set aside the flask.

For an optimum counting, allow radioactive equilibrium between the ^{222}Rn and its short-lived decay products (^{214}Po , ^{218}Po) to be reached in the scintillation cell. The radioactive equilibrium is reached 3 h after the radon gas is introduced into the scintillation cell.

Place the scintillation cell on the detector photocathode and count for at least 1 h, or perform repeated counts to ensure equilibrium is achieved. The time the counting starts is t_2 .

Finally, immediately after counting, flush the scintillation cell with a radon-free gas in order to avoid a further accumulation of $^{210}\text{Pb}/^{210}\text{Po}$ in the cell.

8 Quality assurance and quality control programme

8.1 General

Quality control operations shall meet the requirements of ISO/IEC 17025.

8.2 Influence parameters

Special precautions shall be taken to minimize the influence of parameters that can affect the measurement results:

- loss of ^{222}Rn from the bubbler and the scintillation cell to be measured: a gas-tight system of bubbler and scintillation cell shall be used.

Wide temporal variations of the radon activity concentration can be observed in the atmosphere of the laboratory. The continuous monitoring of the ^{222}Rn activity concentration in the laboratory using a radon-measuring device is recommended since, even in well-ventilated rooms, considerable variations are possible in special weather conditions (see References [2] and [3]).

The continuous renewal of the air through an air-conditioning system is suggested to maintain a constant temperature and relative humidity.

The painting of the walls of the laboratory with a suitable material is suggested in order to limit the release of radon from the material within the walls (e.g. epoxy paints) (see Reference [10]).

8.3 Instrument verification and calibration

Major instrument parameters (PMT high voltage setting, counting yield, background count rate) shall be periodically checked within a quality assurance programme established by the laboratory and following the manufacturer's instructions.

Make sure the whole of the data acquisition chain is correctly set. To do so, use the alpha-emitting constant radioactive source (e.g. ^{239}Pu) to check that the data acquisition chain gives the expected value of the source.

As the decay of an atom of ^{222}Rn and its decay products ^{218}Po and ^{214}Po result in three alpha-emissions to arrive at ^{210}Pb , the term "yield" to be used is thus equal to the detection yield multiplied by three.

The total efficiency can vary over time and so it shall be determined at intervals by degassing ^{222}Rn from a standard solution of ^{226}Ra with known activity (contained in a bubbler), with the procedure used for the assay.

8.4 Method verification

Periodical verifications of the accuracy of the method shall be run. These can be accomplished by

- participating in intercomparison exercises and
- analysing reference materials.

8.5 Demonstration of analyst capability

If an analyst has not used this procedure before, a precision and bias test shall be performed by running a duplicate measurement of a reference or spiked material. Acceptance limits shall be defined by the laboratory.

A similar test shall be performed by analysts routinely using this procedure with a periodicity defined by the laboratory. Acceptance limits shall be defined.

9 Expression of results

9.1 Activity concentration of water-soluble ^{226}Ra

The activity concentration of water-soluble ^{226}Ra , c_A , is obtained from Formula (1):

$$c_A = \frac{(\bar{N} - \bar{N}_0)}{t_c \epsilon n_\alpha(t) V f_a f_d} = (\bar{N} - \bar{N}_0) \omega \quad (1)$$

where

$$\bar{N} = \frac{\sum_{j=1}^n N_j}{n}$$

$$\bar{N}_0 = \frac{\sum_{j=1}^n N_{0j}}{n}$$

$$\omega = \frac{1}{t_c \varepsilon n_\alpha(t) V f_a f_d} \quad (2)$$

where

$$f_a = 1 - \exp[-\lambda(t_1 - t_0)] \quad (3)$$

$$f_d = \exp[-\lambda(t_2 - t_1)] \quad (4)$$

When the radioactive equilibrium between radon and its decay products is reached, $n_\alpha(t) \approx 3$ and Formula (1) can be simplified.

9.2 Standard uncertainty of activity concentration

9.2.1 General

The standard uncertainty of c_A is obtained as given in Formula (5):

$$u(c_A) = \sqrt{(\bar{N} + \bar{N}_0) \frac{\omega^2}{n} + c_A^2 u_{\text{rel}}^2(\omega)} \quad (5)$$

The relative standard uncertainty of ω is calculated using Formula (6):

$$u_{\text{rel}}^2(\omega) = u_{\text{rel}}^2(\varepsilon) + u_{\text{rel}}^2(V) \quad (6)$$

where the uncertainties of the counting time, the decay constant, and the number of alpha-emitters are neglected.

The calculation of the characteristic limits (see Reference [4]) requires the calculation of $\tilde{u}(\tilde{c}_A)$, i.e. the standard uncertainty of c_A as a function of its true value, calculated as given in Formula (7):

$$\tilde{u}(\tilde{c}_A) = \sqrt{\left(\frac{\tilde{c}_A}{\omega} + 2\bar{N}_0 \right) \frac{\omega^2}{n} + \tilde{c}_A^2 u_{\text{rel}}^2(\omega)} \quad (7)$$

9.2.2 Decision threshold

The decision threshold, c_A^* , is obtained from Formula (7) for $\tilde{c}_A = 0$ (see Reference [4]).

This yields to Formula (8):

$$c_A^* = k_{1-\alpha} \tilde{u}(0) = k_{1-\alpha} \omega \sqrt{\frac{2\bar{N}_0}{n}} \quad (8)$$

where $\alpha = 0,05$ with $k_{1-\alpha} = 1,65$ is often chosen by default.

9.2.3 Detection limit

The detection limit, $c_A^\#$, is calculated as given in Formula (9) (see Reference [4]):

$$c_A^\# = c_A^* + k_{1-\beta} \tilde{u}(c_A^\#) = c_A^* + k_{1-\beta} \sqrt{\left(\frac{c_A^\#}{\omega} + 2\bar{N}_0\right) \frac{\omega^2}{n} + c_A^{\#2} u_{rel}^2(\omega)} \tag{9}$$

where $\beta = 0,05$ with $k_{1-\beta} = 1,65$ is often chosen by default.

The detection limit can be calculated by solving Formula (9) for $c_A^\#$ or, more simply, by iteration with a starting approximation $c_A^\# = 2c_A^*$ in terms of the right side of Formula (9).

With $k_{1-\alpha} = k_{1-\beta} = k$:

$$c_A^\# = \frac{2c_A^* + k^2(\omega/n)}{1 - k^2 u_{rel}^2(\omega)} \tag{10}$$

where values $\alpha = \beta = 0,05$ and therefore, $k_{1-\alpha} = k_{1-\beta} = 1,65$ are often chosen by default.

9.3 Limits of the confidence interval

The lower, $c_A^<$, and upper, $c_A^>$, limits of the confidence interval are calculated using Formulae (11) and (12) (see Reference [4]):

$$c_A^< = c_A - k_p u(c_A) ; p = \omega(1 - \gamma/2) \tag{11}$$

$$c_A^> = c_A + k_q u(c_A) ; q = 1 - \frac{\omega\gamma}{2} \tag{12}$$

where $\omega = \Phi[y/u(y)]$, Φ being the distribution function of the standardized normal distribution.

If $c_A \geq 4u(c_A)$, ω can be set to unity. In this case:

$$c_A^{\langle \triangleright \rangle} = c_A \pm k_{1-\gamma/2} u(c_A) \tag{13}$$

$\gamma = 0,05$ with $k_{1-\gamma/2} = 1,96$ are often chosen by default.

9.4 Example

For an accumulation time of 5 d, 19 h, and a decay time of 3 h and 30 min, the counting time is 1 h.

$f_a = 0,65$	$f_d = 0,974$	$V = 0,50 \text{ l} \pm 0,01 \text{ l}$	$\varepsilon = 0,60 \pm 0,03$
$N = 1\,849$ pulses	$N_0 = 262$ pulses	$t_c = 3\,600$ s	$n = 1$
$c_A = 0,77 \text{ Bq l}^{-1}$	$u(c_A) = 0,047 \text{ Bq l}^{-1}$	$c_A^* = 0,018 \text{ Bq l}^{-1}$	$c_A^\# = 0,038 \text{ Bq l}^{-1}$

10 Test report

This test report shall meet the requirements of ISO/IEC 17025 and shall contain at least the following information:

- a) the test method used, together with a reference to this part of ISO 13165 (i.e. ISO 13165-2:2014);
- b) a reference to the measuring and evaluation procedure implemented;

- c) the identification of the sample;
- d) the measurement date;
- e) the units in which the results are expressed;
- f) the test result, $c_A \pm u(c_A)$ or $c_A \pm U$, with the associated k -value and the reference date.

Complementary information can be provided such as the following:

- g) the probabilities α , β , and $(1 - \gamma)$;
- h) the decision threshold and the detection limit; depending on the customer request, there are different ways to present the result:
 - when the ^{226}Ra activity concentration is compared with the decision threshold (see Reference [4]), the result of the measurement shall be expressed as $\leq c_A^*$ when the result is below the decision threshold;
 - when the ^{226}Ra activity concentration is compared with the detection limit, the result of the measurement can be expressed as $\leq c_A^\#$ when the result is below the detection limit. If the detection limit exceeds the guideline value, it shall be documented that the method is not suitable for the measurement purpose;
- i) a mention of any relevant information likely to affect the results.

The test report can be completed by any useful information according to ISO/IEC 17025.

Annex A (informative)

Decay chains of uranium-238 and thorium-232

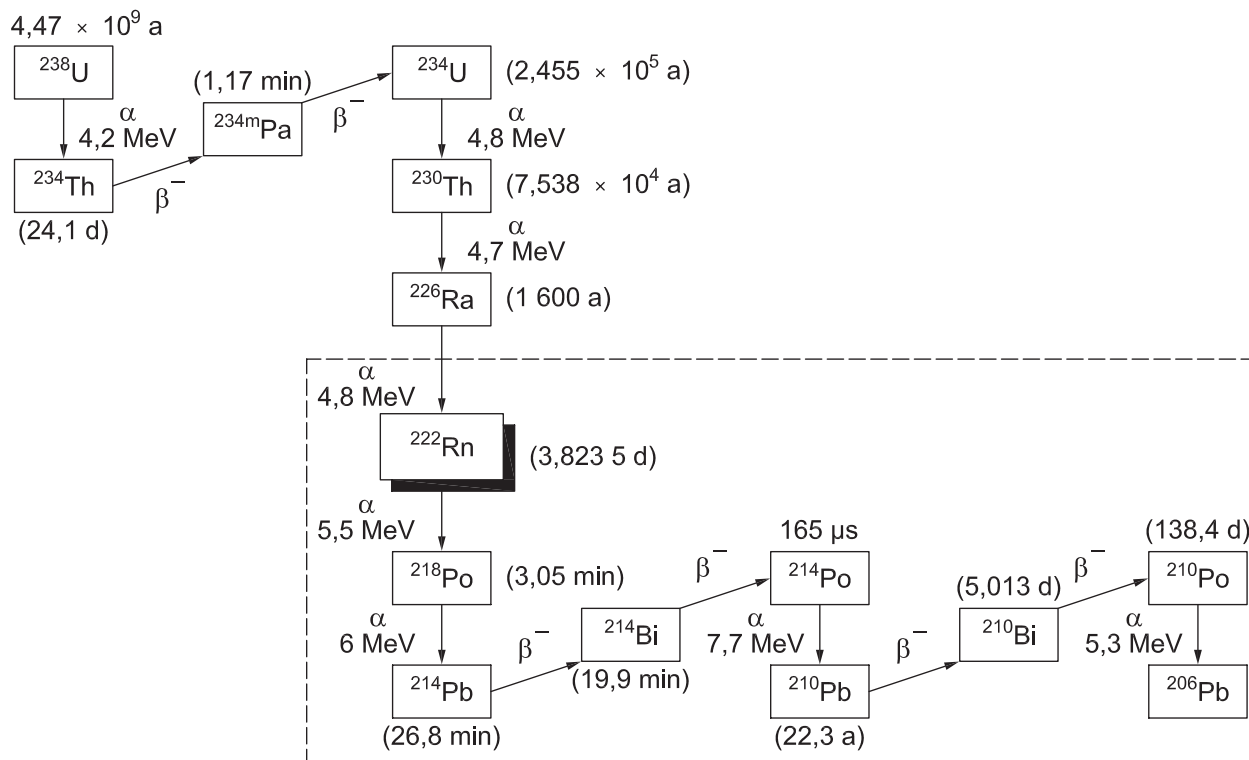

Figure A.1 — Uranium-238 and its decay chain (see Reference [9])

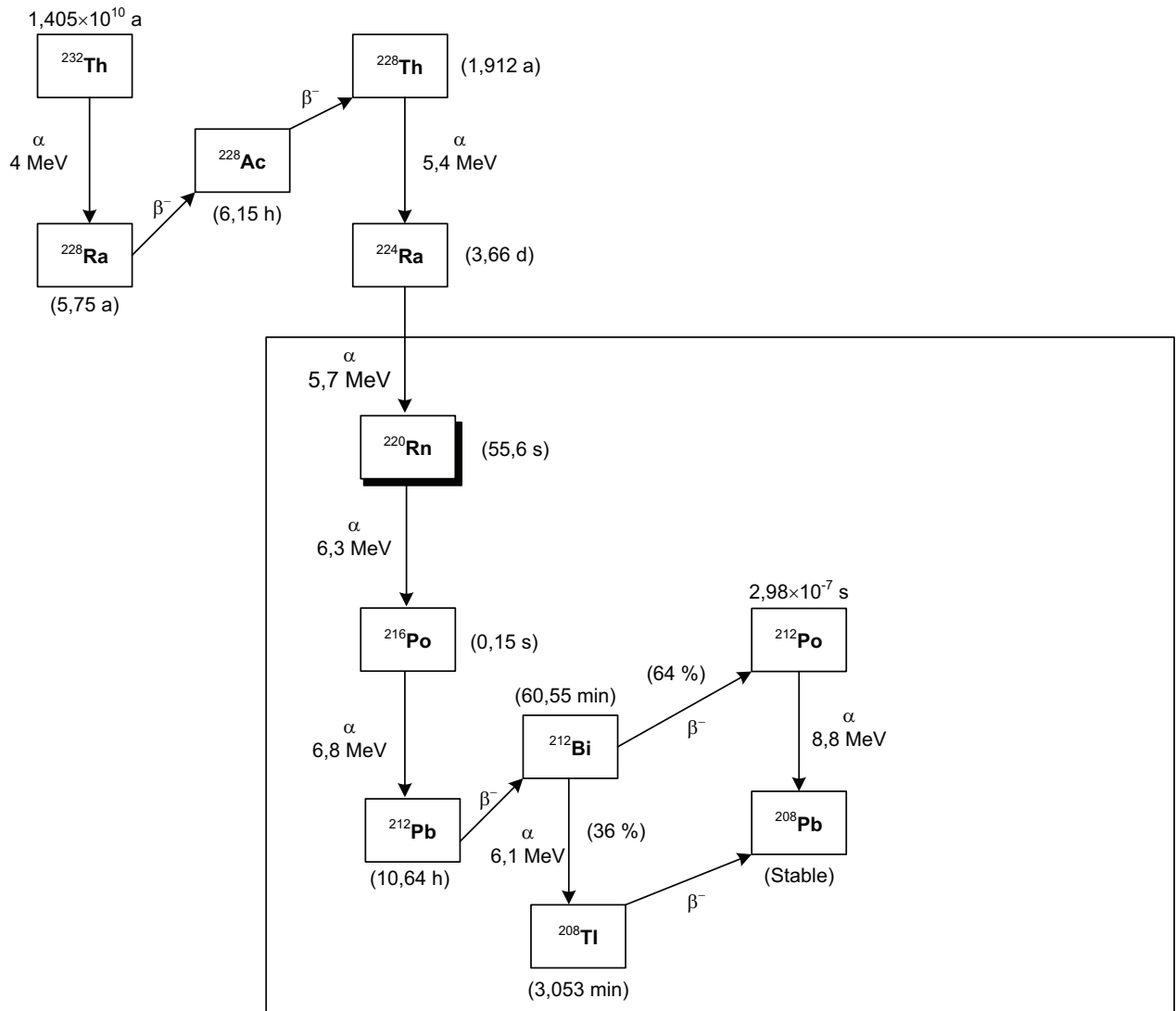
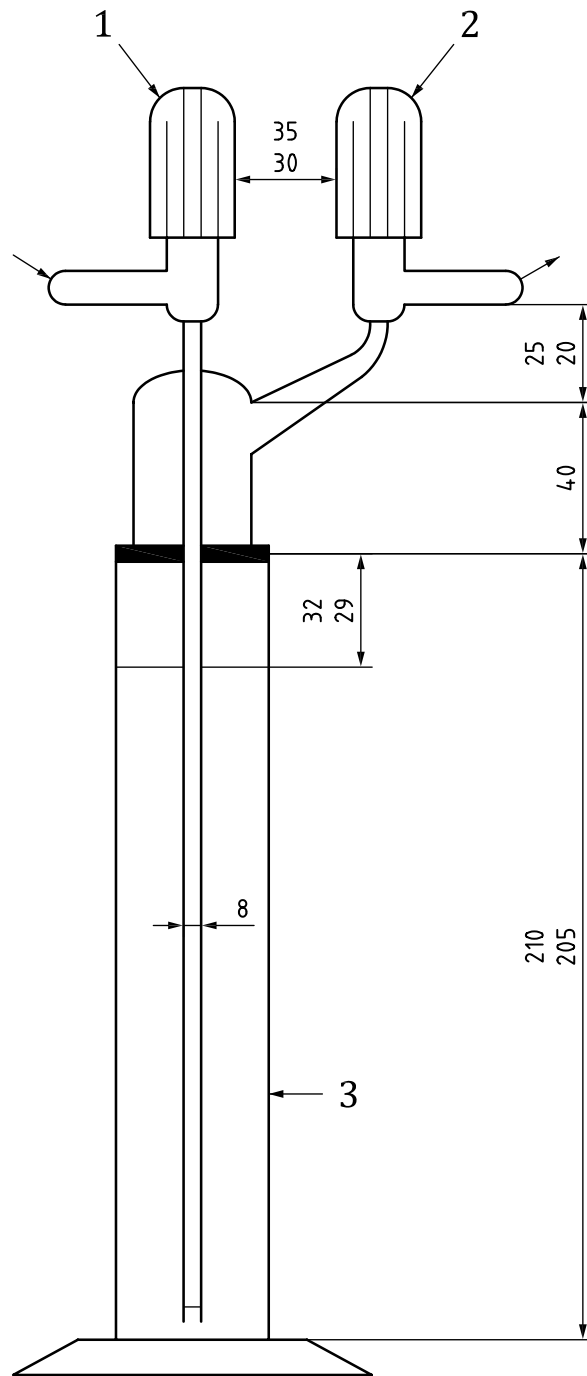

Figure A.2 — Thorium-232 and its decay chain (see Reference [9])

Annex B
(informative)

Bubbler

Dimensions in millimetres



Key

- 1 valve 1
- 2 valve 2
- 3 tube GRD 100

Figure B.1 — Bubbler

Annex C
(informative)

Glass scintillation cell

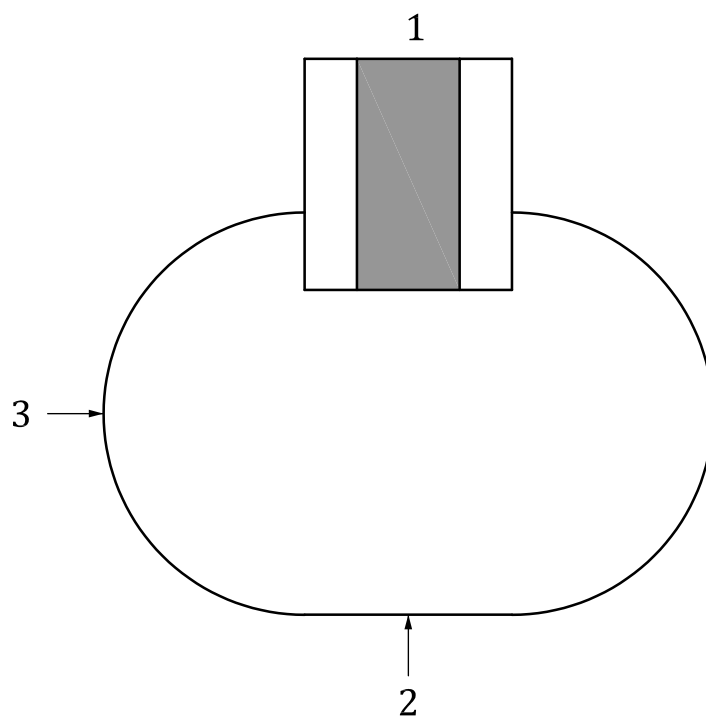

Key

- 1 volume of 500 ml or 250 ml
- 2 measurement window in contact with the photomultiplier
- 3 lined wall

Figure C.1 — Glass scintillation cell coated with silver-activated zinc sulfide

Bibliography

- [1] ISO 10703, *Water quality — Determination of the activity concentration of radionuclides — Method by high resolution gamma-ray spectrometry*
- [2] ISO 11665-1, *Measurement of radioactivity in the environment — Air: radon-222 — Part 1: Origins of radon and its short-lived decay products and associated measurement methods*
- [3] ISO 11665-5, *Measurement of radioactivity in the environment — Air: radon-222 — Part 5: Continuous measurement method of the activity concentration*
- [4] ISO 11929, *Determination of the characteristic limits (decision threshold, detection limit and limits of the confidence interval) for measurements of ionizing radiation — Fundamentals and application*
- [5] EAL-G12:1995, Traceability of measuring and test equipment to national standards
- [6] ASTM D3454, *Standard test method for radium-226 in water*
- [7] NF M 60-790-4, *Énergie nucléaire — Mesure de la radioactivité dans l'environnement-Sol — Partie 4: méthode pour une mise en solution des échantillons de sol*
- [8] LUCAS H.F. Improved low-level alpha-scintillation counter for radon. *Rev. Sci. Instrum.* 1957, **28** pp. 680–683
- [9] LABORATOIRE NATIONAL HENRI BECQUEREL. Nuclear data base: Decay data evaluation project. Available (viewed 2013-01-22) at: http://www.nucleide.org/DDEP_WG/DDEPdata.html
- [10] QUANLU G., & HENGDE W. Sources and protection measures for indoor radon. *Radiat. Prot. Dosimetry.* 1998, **76** pp. 261–266
- [11] WHO. Guidelines for drinking-water quality, 4 edition. Geneva: World Health Organization. 2011. 541 p. Available (viewed 2012-12-10) at: http://www/who.int/water_sanitation_health/publications/2011/dwq_chapters/en/index.html

.....

ICS 17.240;13.060.60

Price based on 15 pages