Laboratory glassware — Desiccators

Verrerie de laboratoire — Dessiccateurs



Reference number
ISO 13130:2011(E)

© ISO 2011



COPYRIGHT PROTECTED DOCUMENT

© ISO 2011

All rights reserved. Unless otherwise specified, no part of this publication may be reproduced or utilized in any form or by any means, electronic or mechanical, including photocopying and microfilm, without permission in writing from either ISO at the address below or ISO's member body in the country of the requester.

ISO copyright office
Case postale 56 • CH-1211 Geneva 20
Tel. + 41 22 749 01 11
Fax + 41 22 749 09 47
E-mail copyright@iso.org
Web www.iso.org

Published in Switzerland

Foreword

ISO (the International Organization for Standardization) is a worldwide federation of national standards bodies (ISO member bodies). The work of preparing International Standards is normally carried out through ISO technical committees. Each member body interested in a subject for which a technical committee has been established has the right to be represented on that committee. International organizations, governmental and non-governmental, in liaison with ISO, also take part in the work. ISO collaborates closely with the International Electrotechnical Commission (IEC) on all matters of electrotechnical standardization.

International Standards are drafted in accordance with the rules given in the ISO/IEC Directives, Part 2.

The main task of technical committees is to prepare International Standards. Draft International Standards adopted by the technical committees are circulated to the member bodies for voting. Publication as an International Standard requires approval by at least 75 % of the member bodies casting a vote.

Attention is drawn to the possibility that some of the elements of this document may be the subject of patent rights. ISO shall not be held responsible for identifying any or all such patent rights.

ISO 13130 was prepared by Technical Committee ISO/TC 48, *Laboratory equipment*, Subcommittee SC 6, *Glass and plastics ware including volumetric instruments*.

Laboratory glassware — Desiccators

1 Scope

This International Standard specifies requirements and tests for desiccators and vacuum desiccators intended for general laboratory purposes such as drying of substances or material.

2 Normative references

The following referenced documents are indispensable for the application of this document. For dated references, only the edition cited applies. For undated references, the latest edition of the referenced document (including any amendments) applies.

ISO 383, *Laboratory glassware — Interchangeable conical ground joints*

ISO 718, *Laboratory glassware — Thermal shock and thermal shock endurance — Test methods*

ISO 3585, *Borosilicate glass 3.3 — Properties*

3 Types

Two types of desiccators are specified in this International Standard.

Type 1 – Vacuum desiccators

Type 2 – Non-vacuum desiccators

4 Nominal sizes and series

Desiccators shall have the following nominal sizes and dimensions.

Series A – Nominal sizes 100, 150, 200, 250 and 300 mm – Dimensions in accordance with Table 1

Series B – Nominal sizes 100, 110, 150, 160, 200, 250 and 300 mm – Dimensions in accordance with Table 2

5 Designation

Desiccators in accordance with this International Standard shall be designated by their nominal size followed by the type and the series.

Designation of a vacuum desiccator with nominal size of 200 mm, Type 1, Series B:

Desiccator ISO 13130 – 200 – 1B

If bodies (item no. 1) and lids (item no. 2) are ordered separately, the following designations shall be used.

Designation of a body (item no. 1) of nominal diameter 200 mm, Type 1, Series B:

Desiccator body ISO 13130 – 200 – 1B – 1

Designation of a lid (item no. 2) of nominal diameter 200 mm, Type 1, Series B:

Desiccator lid ISO 13130 – 200 – 1B – 2

6 Material

Desiccators shall be made of borosilicate glass 3.3 in accordance with ISO 3585. The glass shall be reasonably free from residual strain and from defects which might impair safety, durability or appearance.

The glass shall not have pronounced deviations from the prevailing tint. To protect light-sensitive substances, the surface of the glass may be coloured brown.

7 Dimensions

Desiccators shall comply with the dimensions specified in Table 1 for Series A and in Table 2 for Series B.

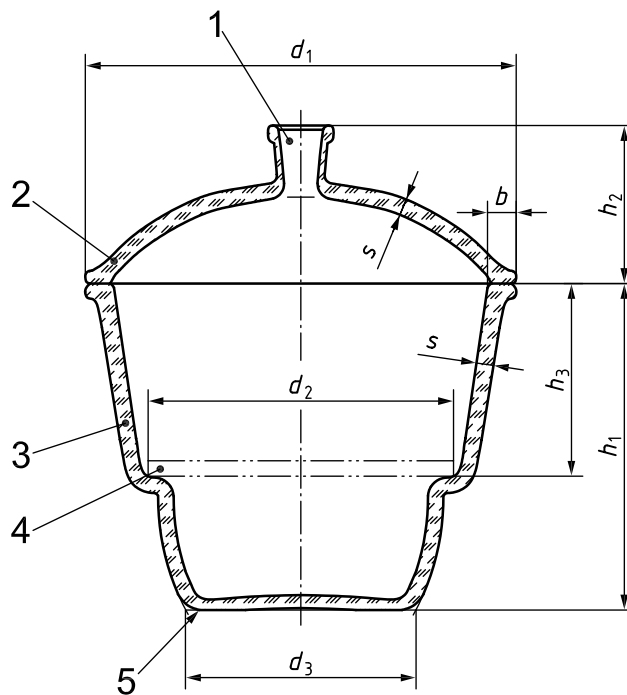

Key

- 1 opening for vacuum
- 2 lid (item no. 2)
- 3 body (item no. 1)
- 4 desiccator plate
- 5 base (picked)

Figure 1 — Vacuum desiccator (example)

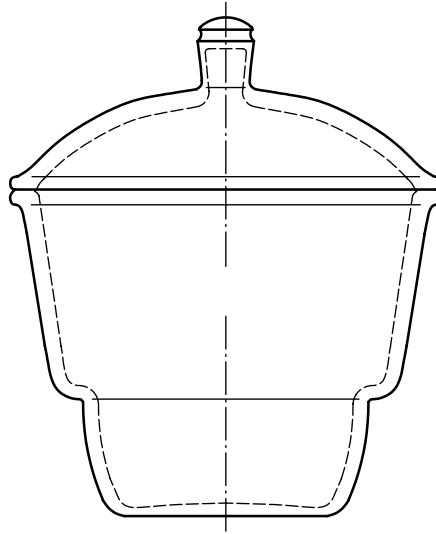

Figure 2 — Non-vacuum desiccator (example)

NOTE The designation of dimensions in Figure 2 is the same as in Figure 1.

Table 1 — Dimensions for Series A desiccators

Dimensions in millimetres

Nominal size	b min.	d_1 ± 2	d_2 min.	d_3 \approx	h_1 max.	h_{2T}^a max.	h_{2K}^b max.	h_3 min.	s min.
100	13	153	92	70	115	65	80	63	4
150	16	215	143	100	160	90	105	87	5
200	18	270	192	145	205	100	110	121	6
250	18	320	239	180	240	115	130	127	7
300	18	380	285	220	290	145	155	157	8 ^c

^a h_{2T} = height of lid with tube or screw thread (vacuum desiccators).
^b h_{2K} = height of lid with knob (non-vacuum desiccators).
^c For nominal size 300, the wall thickness of the lid may be reduced to 7 mm.

Table 2 — Dimensions for Series B desiccators

Dimensions in millimetres

Nominal size	b min.	d_1 ± 3	d_2 min.	d_3 min.	h_1 max.	h_2^a max.	h_3 max.	s min.
100	13	155	95	65	115	55	60	4
110	13	160	100	70	110	75	70	5
150	16	195	140	115	160	95	85	5
160	16	200	145	120	161	100	110	6
200	16	270	180	125	205	115	120	6
250	20	330	230	160	240	138	135	7
300	22	380	280	185	285	140	151	8 ^b

^a h_2 applies for vacuum desiccators of the sleeve type.
^b For nominal size 300, the wall thickness of the lid may be reduced to 7 mm.

8 Construction

8.1 Basic requirements

Desiccators shall be regular in shape (see Figure 1 and Figure 2) and smoothly finished. They shall be symmetrical about the axis which shall be perpendicular to the thought plane of the base.

8.2 Base

Desiccators shall have a slightly concave base enabling the desiccator to stand vertically without rocking or spinning on a plane horizontal surface. To increase the stability and protection against mechanical damage or cracking,

- extra glass may be provided externally to form a protective rim at the base, and/or
- the outer surface of the base shall be picked along the circumference.

8.3 Side

The side of the desiccators shall be stepped to accommodate perforated desiccator plates (e.g. in accordance with national standards) without rocking, in a plane parallel to the base. The upper part of the side above the step shall rise in the approximate form of a vertical slightly tapered cylinder and end in a horizontal flat flange. See Figure 1 and Figure 2.

8.4 Lid

The lid of desiccator shall be part-spherical in shape. Its rim shall form a flat flange the surface of contact of which shall match that of the flat flange of the body of the desiccator evenly.

The lid shall be provided at the top either with a vacuum connection or with a knob of minimum diameter 38 mm for ease of handling. The knob may be solid or hollow.

8.5 Flat flange and tightness

The vacuum-tight surfaces of the flanges of the body and the lid shall be separately ground plane so that they are interchangeable. They shall be ground fine so that the assembled desiccator, or its body or lid when tested separately, complies with the following requirement.

The leakage rate of closed desiccators shall not exceed $3 \text{ mbar} \times l \times \text{s}^{-1}$. This is to be tested with paired bodies and lids, selected at random and with the flange face dry, in accordance with national or International Standards.

The flat flange of the body may be furnished with a ring-groove to incorporate a matching elastomeric seal.

8.6 Vacuum connection

Desiccators of Type 1 shall have an opening for vacuum connection located either in the top centre of the lid or in the side wall of the body at a height equal to $\frac{1}{2} h_1$ (see Figure 1).

The opening for the vacuum connection shall have the form

- of a conical ground glass socket size 24/29 in accordance with ISO 383, or
- of an external screw thread in accordance with suitable national or International Standards, or
- of a socket for take-up of a rubber stopper, or

- of a ground knob with a sleeve and tube in alignment with the opening in the knob. The bore size shall be minimum 2 mm and the internal diameter of the tube shall match the bore size.

8.7 Pressure strength

Vacuum desiccators (Type 1) shall be capable of resisting an external pressure of 2 bar for 60 s or an external pressure of 3 bar for 10 s. Testing shall be conducted in accordance with Annex A.

8.8 Protective coating

For protection against mechanical damage (impact or shock), the body and lid of desiccators may have an external plastic coating.

9 Thermal shock endurance

Desiccators shall be type tested to comply with a thermal shock endurance of 80 °C in accordance with ISO 718.

10 Marking and packaging

10.1 Desiccators shall be permanently and legibly marked on the body and the lid with the following:

- a) manufacturer's and/or supplier's name and/or trade mark;
- b) nominal size or designation;
- c) type (vacuum or non-vacuum desiccator);
- d) optionally the number of this International Standard, "ISO 13130".

10.2 Desiccators shall be packed individually as agreed to between the purchaser and the supplier to protect them from damage during transit and storage.

11 Appearance of used desiccators

Before a vacuum is applied to the desiccator, it shall always be checked visually to verify that its internal and external surfaces are free from defects such as chipping, cracks or grooves. Particular attention shall be paid to the base and to the side wall at the step.

Damaged desiccators shall not be used.

Annex A (normative)

Type test for pressure strength

A.1 General

The desiccator is tested in a pressure vessel by subjecting it to a hydraulic external pressure of 2 bar for 1 min or an external pressure of 3 bar for 10 s.

A.2 Apparatus

A.2.1 Pressure vessel, with a pressure gauge connected to a water reservoir fitted with a ram pump and a release valve discharging back into the reservoir. The lid of the pressure vessel can be fastened to the vessel by means of wing nuts for ease of operation.

The recommended apparatus is illustrated in Figure A.1.

A.3 Procedure

Assemble the desiccator after cleaning and greasing the flange faces (and the cone and socket in case of Type 1) and close the desiccator at atmospheric pressure. To ensure submersion, hold the desiccator in the pressure vessel in some holding device or, alternatively, place weights wrapped in paper or cloth inside it. Having placed the desiccator in position and fastened the lid, fill the pressure vessel with water and bring up the pressure to 2 bar by working the ram pump and release it immediately after 1 min.

A.4 Result

The desiccator shall be considered to have satisfied the requirement of the test if it withstands the pressure of 2 bar for 1 min. Alternatively, the test may be performed at 3 bar for 10 s.

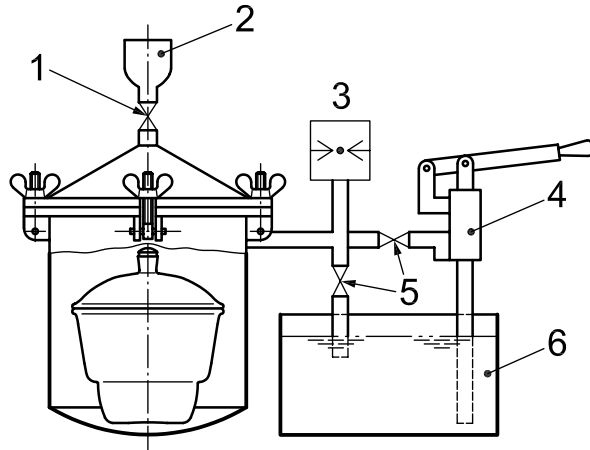

Key

- 1 pressure relief valve
- 2 funnel
- 3 pressure gauge
- 4 pump
- 5 valves
- 6 reservoir

Figure A.1 — Test rig for pressure strength

ICS 11.100.01; 71.040.20

Price based on 7 pages