**Building construction machinery and
equipment — Machinery for concrete
surface floating and finishing —**

**Part 2:
Safety requirements and verification**

*Machines et matériels pour la construction des bâtiments —
Talocheuses-lisseuses de mortier —*

Partie 2: Les exigences de sécurité et de vérification





COPYRIGHT PROTECTED DOCUMENT

© ISO 2014

All rights reserved. Unless otherwise specified, no part of this publication may be reproduced or utilized otherwise in any form or by any means, electronic or mechanical, including photocopying, or posting on the internet or an intranet, without prior written permission. Permission can be requested from either ISO at the address below or ISO's member body in the country of the requester.

ISO copyright office
Case postale 56 • CH-1211 Geneva 20
Tel. + 41 22 749 01 11
Fax + 41 22 749 09 47
E-mail copyright@iso.org
Web www.iso.org

Published in Switzerland

Contents

	Page
Foreword	iv
Introduction	v
1 Scope	1
2 Normative references	1
3 Terms and definitions	2
4 Safety requirements and/or protective/risk reduction measures	2
4.1 General requirements for all machines	2
4.2 Safety requirements for pedestrian-controlled machines	4
4.3 Safety requirements for ride-on machines	5
5 Verification of safety requirements and/or protective/risk reduction measures	6
6 Information for use	6
6.1 Operator's manual	6
6.2 Safety and instructional signs	7
6.3 Marking	7
Annex A (normative) Noise and vibration tests	9
Annex B (informative) List of significant hazards	12
Bibliography	14

Foreword

ISO (the International Organization for Standardization) is a worldwide federation of national standards bodies (ISO member bodies). The work of preparing International Standards is normally carried out through ISO technical committees. Each member body interested in a subject for which a technical committee has been established has the right to be represented on that committee. International organizations, governmental and non-governmental, in liaison with ISO, also take part in the work. ISO collaborates closely with the International Electrotechnical Commission (IEC) on all matters of electrotechnical standardization.

The procedures used to develop this document and those intended for its further maintenance are described in the ISO/IEC Directives, Part 1. In particular the different approval criteria needed for the different types of ISO documents should be noted. This document was drafted in accordance with the editorial rules of the ISO/IEC Directives, Part 2 (see www.iso.org/directives).

Attention is drawn to the possibility that some of the elements of this document may be the subject of patent rights. ISO shall not be held responsible for identifying any or all such patent rights. Details of any patent rights identified during the development of the document will be in the Introduction and/or on the ISO list of patent declarations received (see www.iso.org/patents).

Any trade name used in this document is information given for the convenience of users and does not constitute an endorsement.

For an explanation on the meaning of ISO specific terms and expressions related to conformity assessment, as well as information about ISO's adherence to the WTO principles in the Technical Barriers to Trade (TBT) see the following URL: [Foreword - Supplementary information](#)

The committee responsible for this document is ISO/TC 195, *Building construction machinery and equipment*, Subcommittee SC 1, *Machinery and equipment for concrete work*.

ISO 13105 consists of the following parts, under the general title *Building construction machinery and equipment — Machinery for concrete surface floating and finishing*:

- *Part 1: Terms and commercial specifications*
- *Part 2: Safety requirements and verification*

Introduction

This part of ISO 13105 is a type-C standard as stated in ISO 12100.

This part of ISO 13105 is of relevance, in particular, for the following stakeholder groups representing the market players with regard to machinery safety:

- machine manufacturers (small, medium, and large enterprises);
- health and safety bodies (regulators, accident prevention organisations, market surveillance, etc.).

Others can be affected by the level of machinery safety achieved with the means of this part of ISO 13105 by the above-mentioned stakeholder groups:

- machine users/employers (small, medium, and large enterprises);
- machine users/employees (e.g. trade unions, organizations for people with special needs);
- service providers, e.g. for maintenance (small, medium, and large enterprises);
- consumers (in the case of machinery intended for use by consumers).

The above-mentioned stakeholder groups have been given the possibility to participate at the drafting process of this part of ISO 13105.

The machinery concerned and the extent to which hazards, hazardous situations, or hazardous events are covered are indicated in the Scope of this part of ISO 13105.

When requirements of this type-C standard are different from those which are stated in type-A or type-B standards, the requirements of this type-C standard take precedence over the requirements of the other standards for machines that have been designed and built according to the requirements of this type-C standard.

ISO 13105 deals with machinery designed for smoothing and finishing concrete on construction sites. These machines are commonly referred to as “power trowels.”

Building construction machinery and equipment — Machinery for concrete surface floating and finishing —

Part 2: Safety requirements and verification

1 Scope

This part of ISO 13105 specifies safety requirements for machines used for concrete surface floating and finishing. This includes pedestrian-controlled equipment and ride-on equipment.

It is not applicable to

- internal or external vibrators or ancillary equipment used with internal and external vibrators, for example, air compressors, hydraulic power sources, and voltage transformers,
- remote-controlled or hand-held smoothing machines and self-acting (robotic) smoothing machines, and
- strike-off type machines commonly known as screeds.

This part of ISO 13105 deals with significant hazards, hazardous situations, or hazardous events relevant to machinery for concrete surface floating and finishing (power trowels) when used as intended and under conditions of misuse which are reasonably foreseeable by the manufacturer.

This part of ISO 13105 is not applicable to machines which are manufactured before the date of its publication.

2 Normative references

The following documents, in whole or in part, are normatively referenced in this document and are indispensable for its application. For dated references, only the edition cited applies. For undated references, the latest edition of the referenced document (including any amendments) applies.

ISO 2631-1, *Mechanical vibration and shock — Evaluation of human exposure to whole-body vibration — Part 1: General requirements*

ISO 3744, *Acoustics — Determination of sound power levels and sound energy levels of noise sources using sound pressure — Engineering methods for an essentially free field over a reflecting plane*

ISO 4413, *Hydraulic fluid power — General rules and safety requirements for systems and their components*

ISO 4414, *Pneumatic fluid power — General rules and safety requirements for systems and their components*

ISO 5349-1, *Mechanical vibration — Measurement and evaluation of human exposure to hand-transmitted vibration — Part 1: General requirements*

ISO 7000, *Graphical symbols for use on equipment — Registered symbols*

ISO 11201, *Acoustics — Noise emitted by machinery and equipment — Determination of emission sound pressure levels at a work station and at other specified positions in an essentially free field over a reflecting plane with negligible environmental corrections*

ISO 12100:2010, *Safety of machinery — General principles for design — Risk assessment and risk reduction*

ISO 13105-2:2014(E)

ISO 13105-1:2014, *Building construction machinery and equipment — Machinery for concrete surface floating and finishing — Part 1: Terms and commercial specifications*

ISO 13732-1, *Ergonomics of the thermal environment — Methods for the assessment of human responses to contact with surfaces — Part 1: Hot surfaces*

ISO 13766, *Earth-moving machinery — Electromagnetic compatibility*

IEC 60204-1, *Safety of machinery — Electrical equipment of machines — Part 1: General requirements*

IEC 60309-1, *Plugs, socket-outlets and couplers for industrial purposes — Part 1: General requirements*

IEC 60529, *Degrees of protection provided by enclosures (IP code)*

3 Terms and definitions

For the purposes of this document, the terms and definitions given in ISO 12100, ISO 13105-1, and the following shall apply.

3.1

nylon 6/6 substrate

polyhexamethylene adipamide material

Note 1 to entry: See ISO 1874-1 for more information.

4 Safety requirements and/or protective/risk reduction measures

Machinery shall comply with the safety requirements and/or protective/risk reduction measures of this Clause.

In addition, the machine shall be designed according to the principles of ISO 12100 for relevant but not significant hazards which are not dealt with by this part of ISO 13105.

4.1 General requirements for all machines

4.1.1 Guarding of the rotating blades

A means shall be provided to protect the operator or bystanders from inadvertently coming in contact with rotating blades. The guarding device shall be designed so that the operator can visually see the interaction of the blades with the concrete surface.

If the guarding device is constructed of tubes (or bars), there shall be a gap not exceeding 90 mm between the concentric tubes (or bars). See ISO 13105-1:2014, Figures A.1 and [A.2](#).

The lowest outer tube (or bar) of the blade guarding device shall be able to withstand an impact force equal to two times the weight of the machine without exposing the blades to the deformation.

4.1.2 Blade guarding device ground clearance

The height of the lowest outer tube (or bar) of the blade guarding device with blades in the unpitched position shall not exceed 60 mm from the concrete surface. See ISO 13105-1:2014, Figures A.1 and [A.2](#).

4.1.3 Blade pitch adjustment

Whenever practicable, the adjustment of the blade pitch shall be carried out from the normal operating position. Where this is neither possible nor practicable, means shall be provided to protect personnel from contact with the blade, e.g. blade lock or equivalent. Instructions for blade pitch adjustment shall be given in the operator's manual. See [6.1.2](#), item t).

4.1.4 Electrical devices

4.1.4.1 Electrical contact of persons with live parts

4.1.4.1.1 Direct contact

Protection from direct contact with live parts shall be in accordance with IEC 60204-1, 6.2.

4.1.4.1.2 Indirect contact

Protection from indirect contact with live parts shall be in accordance with IEC 60204-1, 6.3.

4.1.4.2 External influences on electrical equipment

4.1.4.2.1 Damage to electrical equipment

The position of the electrical equipment in the machinery shall guarantee protection from mechanical damage to electrical equipment.

Flexible leads with insulation meeting specification H 07 RN-F or A 07 RN-F per EN 50525-2-21:2011 or at least equivalent specification shall be used.

Plug devices shall be qualified for more difficult (rough) conditions in accordance with IEC 60309-1.

4.1.4.2.2 Protection from dust

Electrical components shall meet the dust protection requirements to IP-5X of electric protection in accordance with IEC 60529, 13.4.

4.1.4.2.3 Protection from water

Electrical components shall meet the water protection requirements to IP-X5 of electric protection in accordance with IEC 60529, 14.2.5.

4.1.4.3 Protection against residual voltages

Live parts having a residual voltage greater than 60 V after the supply has been disconnected shall be discharged to 60 V or less within a time period of 5 s after disconnection of the supply voltage provided that this rate of discharge does not interfere with the proper functioning of the equipment.

4.1.4.4 Prevention of the occurrence of a touch voltage

For engine powered machines which generate electrical power above 60 V for accessories, the requirements of IEC 60204-1, 6.3.2 shall apply.

4.1.4.5 Failure of electrical energy source

The machine shall be designed to prevent unintentional starting of the machine after re-energizing subsequent to the failure of electrical energy supply.

4.1.5 Hot parts

The machine shall be designed to minimize risk to the operator from inadvertent contact with hot parts in accordance with ISO 13732-1.

4.1.6 Operator exposure to harmful gases

Exhaust gases of the internal combustion engine shall be directed away from the operator.

4.1.7 Securing of machine parts

Machine parts (e.g. guards) shall be secured to prevent unintentional loosening or displacement during operation or machine lifting.

4.1.8 Means for lifting

For machines with a gross weight of 25 kg or greater, means for lifting (e.g. lifting points) the machine shall be provided. These provisions shall be arranged in such a way that the machine can be lifted, held, and lowered in a stable equilibrium state.

Lift points and devices shall be clearly identified on the machine per [6.3.2](#).

4.1.9 Provisions for securing during transport

Provisions shall be in place to secure the machine during transport (i.e. tie-downs, enclosed vehicle).

Securing points on the machine shall be clearly identified per [6.3.3](#).

4.1.10 Noise reduction

Noise reduction shall be an integral part of the design process, thus specifically taking into account measures at source. See [Annex A](#) for details.

4.1.11 Vibration reduction

Vibration reduction shall be an integral part of the design process, thus specifically taking into account measures at source. See [Annex A](#) for details.

4.1.12 Electromagnetic compatibility (EMC)

The relevant EMC requirements shall be in accordance with ISO 13766.

4.2 Safety requirements for pedestrian-controlled machines

4.2.1 Handle (pole)

4.2.1.1 Horizontal distance from the handle (pole) to the most external guarding device bar (tube)

The horizontal distance from the controls at the handle (pole) to the most outside part of the protection device shall not be less than 900 mm. See ISO 13105-1: 2014, Figure A.1.

4.2.1.2 Handle (pole) rotation

For engine-powered machines, a means shall be provided to automatically stop handle (pole) rotation in the event the handle is inadvertently released while the blades are in motion. The handle (pole) shall not turn more than 270° from the release position.

For electrically-powered machines, a means shall be provided to reduce power to 25 Joules or less in the event the handle is inadvertently released while the blades are in motion.

Means shall be provided to prevent the handle (pole) from rotating during engine start.

4.2.1.3 Loss of stability

The design of the handle shall take into consideration the maximum static and dynamic loads when used as intended.

4.2.1.4 Controls and adjustment

During normal operation, controlling or adjustment of machine shall only be possible from the operator's position by using the hand controls on the handle (pole).

4.2.2 Unintentional starting of blades

If a disruption of power occurs, a means shall be provided e.g. reset switch, to enable restarting of the blades but only after completing the restart procedure as defined by the manufacturer.

4.2.3 Hand operated starting devices

Engine-powered machines shall be equipped with a pull-type starting device.

The pull rope of pull-type starting device shall be securely attached to the starting device.

During and after engine start with the pull-type starting device, there shall be no automatic movement of the machine or its equipment.

4.3 Safety requirements for ride-on machines

4.3.1 Controls

4.3.1.1 General

During normal operation, operating of controls or adjustment of machine shall only be possible from the operator's position, with the operator in the seated position.

The pedal on the ride-on machine shall be so designed that unintentional motion activation while the operator is not in a position to control the machine is not possible.

4.3.1.2 Blade motion controls

When the blade motion control device is released it shall return to a neutral position and the blades shall automatically come to a stop.

After vacating the operator's seat, the blade rotation shall stop, and the speed of the engine shall be brought to idle, or the engine on the ride-on machine shall be automatically stopped.

4.3.1.3 Steering controls

Steering controls shall have neutral positions and automatically return to that position when the control is released by the operator.

The movement of controls on the ride-on machine shall represent the intended movement of the machine, and prevent the movement of the machine in the wrong direction.

4.3.2 Hydraulic system (if equipped)

The hydraulic system shall be designed in compliance with the requirements of ISO 4413. If leakage occurs either internally or externally, it shall not cause a hazard.

4.3.3 Pneumatic system (if equipped)

The pneumatic system shall be designed in compliance with the requirements of ISO 4414. If leakage occurs either internally or externally, it shall not cause a hazard.

5 Verification of safety requirements and/or protective/risk reduction measures

This Clause contains methods of testing of safety requirements stated in [Clause 4](#). All safety measures of [Clause 4](#) should contain self-evident means for verification.

If this means is not self-evident, either one or a combination of the following shall be used to verify that the requirements of [Clause 4](#) have been met:

- measurement;
- visual examination;
- as appropriate, testing means of a method prescribed in this part of ISO 13105 referred to in any particular requirement.

6 Information for use

6.1 Operator's manual

6.1.1 General

An operator's manual shall be supplied with each machine.

6.1.2 Content

The operator's manual shall give instructions for operation and maintenance. The format and content shall be in accordance with ISO 12100:2010, 6.5.

It shall also include, as a minimum:

- a) a description of the machine;
- b) the machine specifications;
- c) the intended use of the machine;
- d) a description of the instrumentation and operator controls;
- e) a statement as to the need for personal protection equipment, as appropriate;
- f) information on the location of any pinch points on the machine that could cause injury during operation or routine maintenance;
- g) instructions to stop the equipment and shut down power before performing any maintenance on the machine;
- h) instructions that all guards need to be in place before operating the machine;
- i) safety-relevant technical data;
- j) an indication that the operator of the machine needs to be trained and competent;
- k) an indication that the operator and other personnel are to fully acquaint themselves with the operator's manual before operating the machine;

- l) a description of the hazard zones around the machine and a warning that all personnel are to stay out of those zones;
- m) hazard zones during machine operation or maintenance;
- n) instructions regarding indoor use, or in confined spaces, as applicable;
- o) operating instructions (e.g. use of intended access systems, proper use of each device, and check procedures);
- p) the procedure for safe set-up, placing, and transportation of the machine;
- q) operation and maintenance of the machine;
- r) the sound power level of exterior noise and its test conditions;
- s) the location and an explanation of all safety related signs affixed to the machine;
- t) instructions for adjusting blade pitch;
- u) any other safety-related items specified in [Clause 4](#) of this part of ISO 13105.

6.2 Safety and instructional signs

Safety labels shall be affixed so as to effectively warn against hazards that are not immediately obvious.

Warnings against obvious hazards shall be conspicuously affixed near the approach or vicinity of the hazard.

Any written or verbal information included in the label or added to the machine (e.g. by stencilling) shall be in the same language(s) as the operator's manual.

All machine safety labels shall be shown and explained in the operator's manual. It is preferred that the location of the label on the machine also be shown in the operator's manual.

NOTE Guidance for safety sign design can be taken from ISO 9244 for earthmoving machines.

6.3 Marking

6.3.1 General

Each machine shall, as a minimum, bear the following minimal information in a permanently legible and indelible condition throughout the expected life of the machine.

- a) name and address of the manufacturer;
- b) mandatory marking;
- c) designation of series or type;
- d) the serial number;
- e) engine power (kW);
- f) mass in kg of the most usual configuration.

6.3.2 Marking of lifting points and devices

Lifting points and devices shall clearly be marked as follows:

- Where lifting takes place using a lifting lug or device, ISO 7000 symbol 1368 or equivalent shall be used.



- Where lifting takes place using forklift pockets, ISO 7000 symbol 2869 or equivalent shall be used.



- Areas where lifting is not permitted with a forklift, the area shall be marked by ISO 7010, symbol P006.



6.3.3 Marking of securing points on the machine for transport

Securing points on the machine for transport shall be clearly marked by ISO 7000 symbol 2069 or equivalent.



Annex A (normative)

Noise and vibration tests

A.1 Test fixture construction

The test fixture shall be designed so that it allows the pitching of the blades to cause sufficient drag on the engine(s) to prevent them from sputtering at full throttle.

The nylon 6/6 substrate test surface material shall be sized accordingly to fit within the rail system.

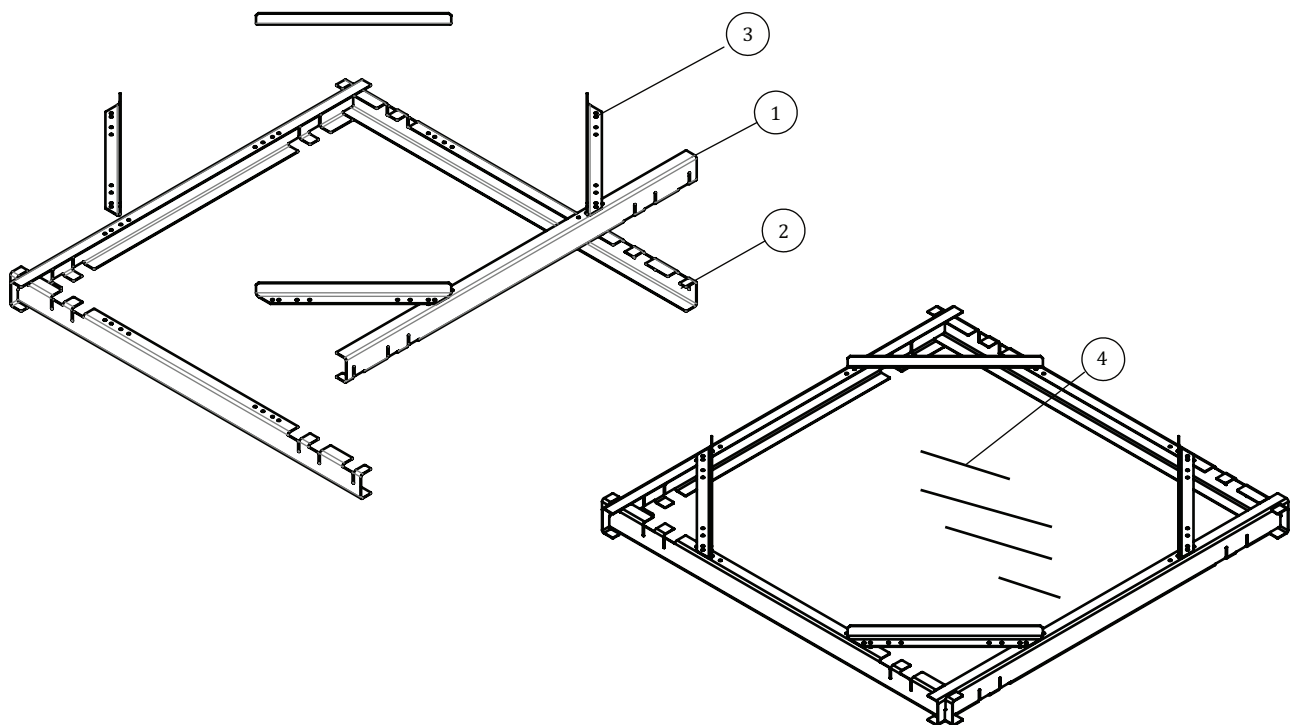

Key

- 1 rail (down) (2)
- 2 rail (up) (2)
- 3 isolator (4)
- 4 nylon 6/6 substrate test surface

Figure A.1 — Example test fixture for noise and vibration tests

A.2 Test surface

A synthetic polymer surface, e.g. nylon 6/6 substrate, shall be used for the test to reduce the possibility of the trowel blades heating up and damaging the test substrate. A lubricant, e.g. molybdenum disulphide, shall be used as an additive to reduce the coefficient of friction on the test surface.

A.3 Securing the machine to the test fixture

The machine being tested shall be positioned on the rail system so that the guard ring is sitting on each of the four rails with sufficient clearance so that the blades do not come in contact with the rail system. See [Figure A.2](#).

Isolators shall be used to securely lock the machine into position on the rail system.

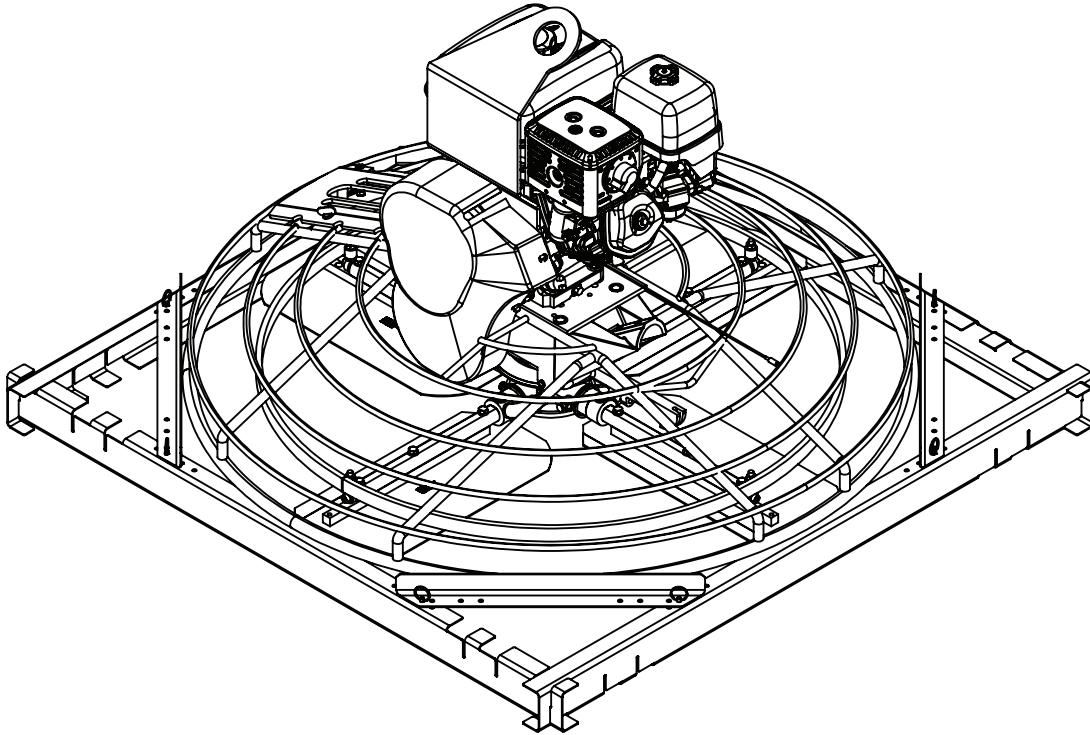

Figure A.2 — Example of machine secured to the test fixture

A.4 Sound measurement

The A-weighted sound power level measurements shall be tested in accordance with ISO 3744. The A-weighted sound pressure level measurements taken at the operator station shall be tested in accordance with ISO 11201.

A.4.1 Operating conditions during test

The equipment shall be positioned such that only the sound generated by the equipment being tested is measured.

A.4.2 Declaration of data

For both the A-weighted sound power level, and the A-weighted sound pressure level at the operator workstation shall be a dual number declaration by giving the measured value and K as defined in ISO 4871.

NOTE No technical data on noise emission are presently available to estimate the standard deviation of reproducibility for concrete compactors and smoothing machines. Therefore, the values of the standard deviation of reproducibility for A-weighted levels stated in ISO 3744, namely 1,5 dB, and ISO 11201, namely 2,5 dB, can be regarded as interim upper boundaries and used for the determination of the uncertainty K when preparing the noise declaration. Investigations requiring a joint effort of manufacturers are necessary to determine a possibly lower value of the standard deviation of reproducibility, which will result in a lower value of the uncertainty K. Results of such investigations will be reflected in a future version of this part of ISO 13105.

A.5 Vibration measurement

The test methods for measuring whole-body vibration and hand-arm vibration shall be in accordance with ISO 2631-1 and ISO 5349-1 respectively.

A.5.1 Blade position for ride-on machines

On ride-on machines with multiple rotors, the blade pitch shall be adjusted, so that all blades have the same pitch angle.

A.5.2 Operating conditions during test

The equipment shall be positioned such that only the vibration generated therefrom is measured.

A.5.3 Whole body vibration measurement for ride-on type power trowel

The use of a human body in the whole-body vibration measurement on a ride-on power trowel may be substituted by using a mass with a weight of 75 kg installed in the seat.

NOTE Weight mass value from the medium operator taken from ISO 3411.

Annex B (informative)

List of significant hazards

The machine should be designed such that it is fit for its purpose or function and can be adjusted and maintained without putting persons at risk when it is used under conditions foreseen by the manufacturer.

To properly design a product and cover all specific safety requirements, the manufacturer should

- identify the hazards that apply to the product and perform risk assessments, and
- design and construct the product taking into account these assessments.

The aim of this procedure is to eliminate or reduce the risk of accidents throughout the foreseeable lifetime of the machinery, including the phases of assembling and dismantling, in which the risk of accidents can also arise from foreseeable abnormal situations.

In selecting the most appropriate methods, the manufacturer should apply the following principles, in the order given:

- a) eliminate or reduce risks as much as possible by design (inherently safe machinery design and construction);
- b) take the necessary protection measures in relation to risks that cannot be eliminated by design;
- c) inform users of the residual risks due to any shortcomings of the protection measures adopted;
- d) indicate whether any particular training is required;
- e) specify any need to provide personal protection equipment (PPE).

The machine should be designed to prevent abnormal use, wherever possible, if such use would engender risk. In other cases, the instructions should draw the user's attention to ways in which experience has shown the machine should not be used.

The following hazards may be applicable and could involve risks to persons if not addressed. The corresponding requirements offer guidance to limit the risk or reduce these hazards.

Table B.1 — List of significant hazards

Ref. No.	Hazard		Subclause of this part of ISO 13105
	Origin (source)	Potential consequences	
1	Mechanical hazards		
	Rotating blades	Cutting or severing of limbs	4.1.1
	Moving transmission parts	Entanglement, severing	4.1.1
	Thrown objects	Injury from impact	4.1.1 , 4.1.7
2	Electrical hazards		
	Live parts of electrical system	Injuries from electrical shock to the body	4.1.4.1.1 , 4.1.4.1.2
3	Thermal hazards		
	Hot parts	Injury from burns and scalds from inadvertent contact	4.1.5
4	Noise hazards		
	Engine, transmission and rotating blades	Discomfort, partial hearing loss, deafness, loss of balance, loss of awareness, stress, interference with speech communications and warning signals	4.1.10
5	Vibration hazards		
	Engine, handles, and seat (if applicable)	Discomfort, neurological, osteo-articular, and vascular disorders	4.1.11
6	Material/substance hazards		
	Engine gases and exhaust	Respiration problems through inhalation of harmful gases	
7	Ergonomic hazards		
	Location and design of controls	Discomfort, fatigue, injuries to locomotor apparatus, loss of control	4.2.1.1 , 4.2.1.2 , 4.2.1.3 , 4.2.1.4 , 4.3.1
8	Combination of hazards		

Bibliography

- [1] ISO 1874-1, *Plastics — Polyamide (PA) moulding and extrusion materials — Part 1: Designation system and basis for specification*
- [2] ISO 3411, *Earth-moving machinery — Physical dimensions of operators and minimum operator space envelope*
- [3] ISO 4871, *Acoustics — Declaration and verification of noise emission values of machinery and equipment*
- [4] ISO 9244, *Earth-moving machinery — Machine safety labels — General principles*
- [5] EN 12649:2008 + A1:2011, *Concrete compaction and smoothing machines — Safety*
- [6] EN 50525-2-21, *Electric cables — Low voltage energy cables of rated voltages up to and including 450/750 V (U0/U) — Part 2-21: Cables for general applications — Flexible cables with crosslinked elastomeric insulation*

