**Ceramic tiles — Definitions, classification,
characteristics and marking**

*Carreaux et dalles céramiques — Définitions, classification,
caractéristiques et marquage*



Reference number
ISO 13006:2012(E)

© ISO 2012



COPYRIGHT PROTECTED DOCUMENT

© ISO 2012

All rights reserved. Unless otherwise specified, no part of this publication may be reproduced or utilized in any form or by any means, electronic or mechanical, including photocopying and microfilm, without permission in writing from either ISO at the address below or ISO's member body in the country of the requester.

ISO copyright office
Case postale 56 • CH-1211 Geneva 20
Tel. + 41 22 749 01 11
Fax + 41 22 749 09 47
E-mail copyright@iso.org
Web www.iso.org

Published in Switzerland

Contents

Page

Foreword	iv
1 Scope	1
2 Normative references	1
3 Terms and definitions	2
4 Classification	4
4.1 Basis of classification	4
4.2 Methods of manufacture	4
4.3 Water absorption according to group	4
5 Characteristics	5
6 Sampling and basis for acceptance	5
7 Requirements	5
8 Marking and specifications	5
8.1 Marking	5
8.2 Product literature	5
8.3 Specifications	5
9 Ordering	6
Annex A (normative) Extruded ceramic tiles with low water absorption $0,5 < E_b \leq 3$ % Group AI_b	10
Annex B (normative) Extruded ceramic tiles $3 \% < E_b \leq 6$ % Group AI_a — Subgroup (Part) 1	13
Annex C (normative) Extruded ceramic tiles $3 \% < E_b \leq 6$ % Group AI_a — Subgroup (Part) 2	16
Annex D (normative) Extruded ceramic tiles $6 \% < E_b \leq 10$ % Group AII_b — Subgroup (Part) 1	19
Annex E (normative) Extruded ceramic tiles $6 \% < E_b \leq 10$ % Group AII_b — Subgroup (Part) 2	22
Annex F (normative) Extruded ceramic tiles $E_b > 10$ % Group AIII	25
Annex G (normative) Dry-pressed ceramic tiles with low water absorption $E_b \leq 0,5$ % Group BI_a	28
Annex H (normative) Dry-pressed ceramic tiles with low water absorption $0,5 \% < E_b \leq 3$ % Group BI_b	31
Annex I (informative)	34
Annex J (normative) Dry-pressed ceramic tiles $3 \% < E_b \leq 6$ % Group BII_a	35
Annex K (normative) Dry-pressed ceramic tiles $6 \% < E_b \leq 10$ % Group BII_b	38
Annex L (normative) Dry-pressed ceramic tiles $E_b > 10$ % Group BIII	41
Annex M (normative) Extruded ceramic tiles with low water absorption $E_b \leq 0,5$ % Group AI_a	44
Annex N (informative) Classification of glazed tiles for floors according to their abrasion resistance ..	47
Annex O (informative)	48
Annex P (informative) Test methods	49
Annex Q (informative)	50
Annex R (informative) Symbols recommended for use	51
Bibliography	52

Foreword

ISO (the International Organization for Standardization) is a worldwide federation of national standards bodies (ISO member bodies). The work of preparing International Standards is normally carried out through ISO technical committees. Each member body interested in a subject for which a technical committee has been established has the right to be represented on that committee. International organizations, governmental and non-governmental, in liaison with ISO, also take part in the work. ISO collaborates closely with the International Electrotechnical Commission (IEC) on all matters of electrotechnical standardization.

International Standards are drafted in accordance with the rules given in the ISO/IEC Directives, Part 2.

The main task of technical committees is to prepare International Standards. Draft International Standards adopted by the technical committees are circulated to the member bodies for voting. Publication as an International Standard requires approval by at least 75 % of the member bodies casting a vote.

Attention is drawn to the possibility that some of the elements of this document may be the subject of patent rights. ISO shall not be held responsible for identifying any or all such patent rights.

ISO 13006 was prepared by Technical Committee ISO/TC 189, *Ceramic tile*.

This second edition cancels and replaces the first edition (ISO 13006:1998), which has been technically revised.

Ceramic tiles — Definitions, classification, characteristics and marking

1 Scope

This International Standard defines terms and establishes classifications, characteristics and marking requirements for ceramic tiles of the best commercial quality (first quality). This International Standard is not applicable to tiles made by other than normal processes of extrusion or dry pressing. It is not applicable to decorative accessories or trim such as edges, corners, skirting, capping, coves, beads, steps, curved tiles and other accessory pieces or mosaics (i.e. any piece that can fit into an area of 49 cm²).

NOTE ISO 10545 (all parts) describes the test procedures required to determine the product characteristics listed in this International Standard. ISO 10545 is divided into 16 parts, each describing a specific test procedure or related matter.

2 Normative references

The following referenced documents are indispensable for the application of this document. For dated references, only the edition cited applies. For undated references, the latest edition of the referenced document (including any amendments) applies.

ISO 1006, *Building construction — Modular coordination — Basic module*

ISO 10545-1, *Ceramic tiles — Part 1: Sampling and basis for acceptance*

ISO 10545-2, *Ceramic tiles — Part 2: Determination of dimensions and surface quality*

ISO 10545-3, *Ceramic tiles — Part 3: Determination of water absorption, apparent porosity, apparent relative density and bulk density*

ISO 10545-4, *Ceramic tiles — Part 4: Determination of modulus of rupture and breaking strength*

ISO 10545-5, *Ceramic tiles — Part 5: Determination of impact resistance by measurement of coefficient of restitution*

ISO 10545-6, *Ceramic tiles — Part 6: Determination of resistance to deep abrasion for unglazed tiles*

ISO 10545-7, *Ceramic tiles — Part 7: Determination of resistance to surface abrasion for glazed tiles*

ISO 10545-8, *Ceramic tiles — Part 8: Determination of linear thermal expansion*

ISO 10545-9, *Ceramic tiles — Part 9: Determination of resistance to thermal shock*

ISO 10545-10, *Ceramic tiles — Part 10: Determination of moisture expansion*

ISO 10545-11, *Ceramic tiles — Part 11: Determination of crazing resistance for glazed tiles*

ISO 10545-12, *Ceramic tiles — Part 12: Determination of frost resistance*

ISO 10545-13, *Ceramic tiles — Part 13: Determination of chemical resistance*

ISO 10545-14, *Ceramic tiles — Part 14: Determination of resistance to stains*

ISO 10545-15, *Ceramic tiles — Part 15: Determination of lead and cadmium given off by glazed tiles*

ISO 10545-16, *Ceramic tiles — Part 16: Determination of small colour differences*

3 Terms and definitions

For the purposes of this document, the terms and definitions given in ISO 1006 and the following apply.

3.1

ceramic tile

thin slab made from clays and/or other inorganic raw materials, generally used as covering for floors and walls, usually shaped by extruding (A) or pressing (B) at room temperature, but may be formed by other processes (C), then dried and subsequently fired at temperatures sufficient to develop the required properties

NOTE Tiles may be glazed (GL) or unglazed (UGL); they are incombustible and are not affected by light.

3.2

porcelain tile

fully vitrified tile with water absorption coefficient less than or equal to a mass fraction of 0,5 %, belonging to groups A_{Ia} and B_{Ia}

3.3

glaze

vitrified covering that is impermeable

3.4

engobed surface

clay-based covering with a matt finish which may be permeable or impermeable

NOTE A tile with an engobed surface is regarded as an unglazed tile.

3.5

polished surface

surface of glazed and unglazed tile which has been given a glossy finish by mechanical polishing as the last stage of manufacture

3.6

extruded tile

tile, whose body is shaped in the plastic state in an extruder, the column obtained being cut into tiles of pre-determined dimension, and which is designated as Group A

NOTE 1 This International Standard classifies extruded tiles as "precision" or "natural". The classification is dependent upon the different technical characteristics as listed in the individual product standards.

NOTE 2 Traditional terms used for extruded products are "split tiles" and "quarry tiles". They commonly indicate double-extruded and single-extruded tiles, respectively. The term "quarry tiles" only refers to extruded tiles with a water absorption coefficient of a mass fraction not exceeding 6 %.

3.7

dry-pressed tile

tile, formed from a finely milled body mixture and shaped in moulds at high pressure, and which is designated as Group B

3.8

water absorption

E_b

percentage of water impregnating a tile, measured in accordance with ISO 10545-3

NOTE Water absorption is expressed as a mass fraction of dry mass.

3.9 Sizes

NOTE The sizes are only defined for rectangular tiles. If the sizes of non-rectangular tiles are required, they are defined by the smallest rectangle into which they fit.

3.9.1**nominal size**

size used to describe the product

See Figures 1 and 2.

3.9.2**work size**

size of a tile specified for manufacturing to which the actual size shall conform within specified permissible deviations

See Figures 1 and 2.

3.9.3**actual size**

size obtained by measuring the face of a tile in accordance with ISO 10545-2

See Figures 1 and 2.

3.9.4**coordinating size**

work size plus the joint width

See Figures 1 and 2.

3.9.5**modular size**

tile and size based on module M, 2 M, 3 M and 5 M and also their multiples or subdivisions, except for tiles with a surface area of less than 9 000 mm²

NOTE See ISO 1006, where 1 M = 100 mm.

See Figures 1 and 2.

3.9.6**non-modular size**

size not based on module M

NOTE 1 See ISO 1006, where 1 M = 100 mm.

NOTE 2 Tiles of these sizes are those commonly used in most countries.

See Figures 1 and 2.

3.9.7**tolerance**

difference between the permissible limits of size

See Figures 1 and 2.

3.10**spacer lug**

projection that is located along certain edges of tiles so that where two tiles are placed together, in line, the lugs on adjacent edges separate the tiles by a distance of not less than the specified width of the joint

See Figure 2.

3.11**rectified tile**

ceramic tile that, after firing, is subjected to a precise mechanical grinding of the edges

NOTE Rectified tiles have tighter dimensional criteria for length and width, straightness of sides, and rectangularity than given in Annexes A to M.

3.12

back feet

parallel ridges running across the back surface of some exterior wall tiles which possess a geometry intended to facilitate an interlocking connection between tile and cement mortar

See Figure 3.

NOTE Back feet dimensions shall be measured with vernier calipers, and each specimen in a 10-tile sample is required to satisfy the requirements in Annexes A to M.

4 Classification

4.1 Basis of classification

Ceramic tiles are divided into groups according to their method of manufacture and their water absorption (see 3.8 and Table 1). The groups do not presuppose the usage of the products.

4.2 Methods of manufacture

The following are the two methods of manufacture:

- method A, extruded tiles (see 3.6);
- method B, dry-pressed tiles (see 3.7).

4.3 Water absorption according to group

4.3.1 General

The following are the three groups according to water absorption, E_b .

4.3.2 Subdivision of the three groups

The three groups are divided into tiles of low, medium and high water absorption, namely Groups I, II and II, respectively.

- a) Tiles of low water absorption, i.e. absorption coefficient less than or equal to a mass fraction of 3 %, $E_b \leq 3$ %, belong to Group I. Group I consists of the following:
 - 1) for extruded tiles
 - i) $E_b \leq 0,5$ % (Group AI_a), and
 - ii) $0,5$ % < $E_b \leq 3$ % (Group AI_b);
 - 2) for dry-pressed tiles:
 - i) $E_b \leq 0,5$ % (Group BI_a);
 - ii) $0,5$ % < $E_b \leq 3$ % (Group BI_b).
- b) Tiles of medium water absorption, i.e. 3 % < $E_b \leq 10$ %, belong to Group II. Group II consists of the following:
 - 1) for extruded tiles
 - i) 3 % < $E_b \leq 6$ % [Group AII_a, Subgroups (Parts) 1 and 2; see Annex B for Subgroup (Part) 1 or Annex C for Subgroup (Part) 2], and

- ii) $6\% < E_b \leq 10\%$ [Group All_b, Subgroups (Parts) 1 and 2; see Annex D for Subgroup (Part) 1 or Annex E for Subgroup (Part) 2];
- 2) for dry-pressed tiles
- i) $3\% < E_b \leq 6\%$ (Group BII_a), and
 - ii) $6\% < E_b \leq 10\%$ (Group BII_b).
- c) Tiles of high water absorption, i.e. $E_b > 10\%$, belong to Group III.

5 Characteristics

The characteristics for different applications of ceramic tiles are given in Table 2.

6 Sampling and basis for acceptance

The sampling and basis for acceptance shall be in accordance with that presented in ISO 10545-1.

7 Requirements

Dimensional and surface quality requirements and physical and chemical properties shall be as given in the relevant/specific annex, of Annexes A to M, for each tile class.

8 Marking and specifications

8.1 Marking

Tiles and/or their packaging are required to bear the following marking:

- a) manufacturer's mark and/or trademark and the country where the tile was manufactured (i.e. country of origin, as determined by the relevant international regulation);
- b) indication of first quality;
- c) type of tile and reference to the appropriate annex of Annexes A to M;
- d) nominal and work sizes, modular (M) or non-modular;
- e) nature of the surface, i.e. glazed (GL) or unglazed (UGL);
- f) any surface treatment applied after firing;
- g) total dry weight which the tiles and their packaging shall not exceed.

Each tile conforming to this International Standard is required to bear on its reverse side or edge, the country where it was manufactured.

8.2 Product literature

Product literature for tiles intended for use on floors shall state the abrasion class or the place of use of glazed tiles.

NOTE See also Annex R for informative symbols.

8.3 Specifications

Tiles shall be designated by the following:

- a) the method of shaping;

- b) the relevant annex of Annexes A to M, covering the specific class of tile;
- c) nominal and work sizes, modular (M) and non-modular;
- d) the nature of the surface, i.e. glazed (GL) or unglazed (UGL);
- e) the addition of back feet, if required.

EXAMPLE 1 Precision extruded tile, ISO 13006:2012, Annex M, AI_a M 25 cm × 12,5 cm (*S_w* 240 mm × 115 mm × 10 mm) GL.

EXAMPLE 2 Natural extruded tile, ISO 13006:2012, Annex A, AI_b 15 cm × 15 cm (*S_w* 150 mm × 150 mm × 12,5 mm) UGL.

EXAMPLE 3 Dry-pressed tile, ISO 13006:2012, Annex G, BI_a M 25 cm × 12,5 cm (*S_w* 240 mm × 115 mm × 10 mm) GL.

EXAMPLE 4 Dry-pressed tile, ISO 13006:2012, Annex L, BIII 15 cm × 15 cm (*S_w* 150 mm × 150 mm × 12,5 mm) UGL.

9 Ordering

Each time that an order is placed, items, such as size, thickness, type of surface, colour, profile, abrasion class for glazed tiles and other properties, shall be agreed upon by the parties concerned.

Table 1 — Classification of ceramic tiles with respect to water absorption and shaping

Shaping	Group I $E_b \leq 3\%$	Group II _a $3\% < E_b \leq 6\%$	Group II _b $6\% < E_b \leq 10\%$	Group III $E_b > 10\%$
A Extruded	Group AI _a $E_b \leq 0,5\%$ (see Annex M)	Group AI _{a-1} ^a (see Annex B)	Group AI _{b-1} ^a (see Annex D)	Group AIII (see Annex F)
	Group AI _b $0,5\% < E_b \leq 3\%$ (see Annex A)	Group AI _{a-2} ^a (see Annex C)	Group AI _{b-2} ^a (see Annex E)	
B Dry pressed	Group BI _a $E_b \leq 0,5\%$ (see Annex G)	Group BII _a (see Annex J)	Group BII _b (see Annex K)	Group BIII ^b (see Annex L)
	Group BI _b $0,5\% < E_b \leq 3\%$ (see Annex H)			

^a Groups AI_a and AI_b are divided into two subgroups (Parts 1 and 2) with different product specifications.

^b Group BIII covers glazed tiles only. There is a low quantity of dry-pressed unglazed tiles produced with water absorption greater than 10 % mass fraction, which is not covered by this product group.

Copyright International Organization for Standardization
 Provided by IHS under license with ISO
 No reproduction or networking permitted without license from IHS

Table 2 — Characteristics required for different applications

Characteristics	Floor		Wall		Test
	Interior	Exterior	Interior	Exterior	Reference
Dimensions and surface quality					
Length and width	X	X	X	X	ISO 10545-2
Thickness	X	X	X	X	ISO 10545-2
Straightness of sides	X	X	X	X	ISO 10545-2
Rectangularity	X	X	X	X	ISO 10545-2
Surface flatness (curvature and warpage)	X	X	X	X	ISO 10545-2
Surface quality	X	X	X	X	ISO 10545-2
Back feet (if specified) ^a				X	Figure 3
Physical property					
Water absorption	X	X	X	X	ISO 10545-3
Breaking strength	X	X	X	X	ISO 10545-4
Modulus of rupture	X	X	X	X	ISO 10545-4
Resistance to deep abrasion — unglazed tiles	X	X			ISO 10545-6
Resistance to surface abrasion — glazed tiles	X	X			ISO 10545-7
Linear thermal expansion ^b	X	X	X	X	ISO 10545-8
Resistance to thermal shock ^b	X	X	X	X	ISO 10545-9
Resistance to crazing — glazed tiles	X	X	X	X	ISO 10545-11
Frost resistance ^c		X		X	ISO 10545-12
Moisture expansion ^b	X	X	X	X	ISO 10545-10
Small colour differences ^b	X	X	X	X	ISO 10545-16
Impact resistance ^b	X	X			ISO 10545-5
Chemical property					
Resistance to staining					ISO 10545-14
— glazed tiles	X	X	X	X	ISO 10545-14
— unglazed tiles ^b	X	X	X	X	ISO 10545-14
Resistance to low concentrations of acids and alkalis	X	X	X	X	ISO 10545-13
Resistance to high concentrations of acids and alkalis ^b	X	X	X	X	ISO 10545-13
Resistance to household cleaners and swimming pool salts	X	X	X	X	ISO 10545-13
Lead and cadmium release — glazed tiles ^b	X	X	X	X	ISO 10545-15
^a For application to exterior tiles installed by cement mortar, including tunnels, where back feet are specified.					
^b Test method is available.					
^c For tiles intended to be used in situations where frost conditions apply.					

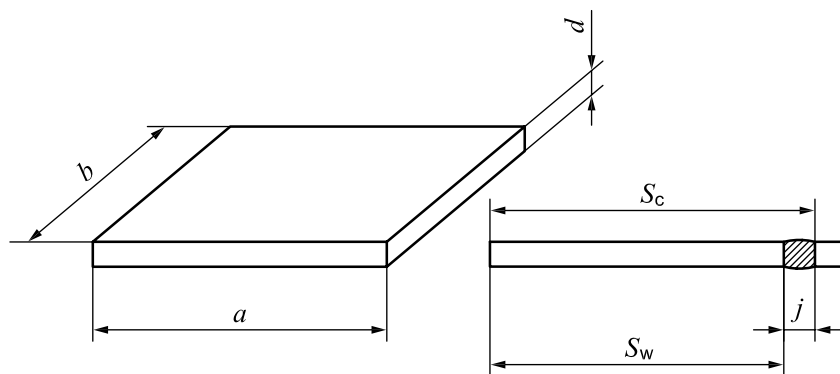

Key

a, b dimensions of the visible face

d thickness

j joint

S_c coordinating size

S_w work size

$$S_c = S_w + j$$

$$S_w = a + b + d$$

Figure 1 — Tile

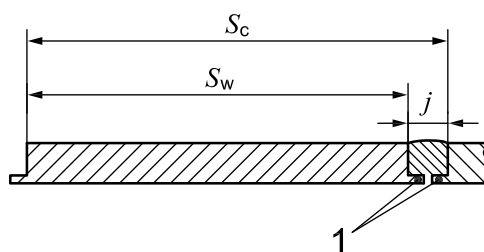

Key

1 spacer lugs

j joint

S_c coordinating size

S_w work size

$$S_c = S_w + j$$

$$S_w = a + b + d$$

Figure 2 — Tile with spacer lug

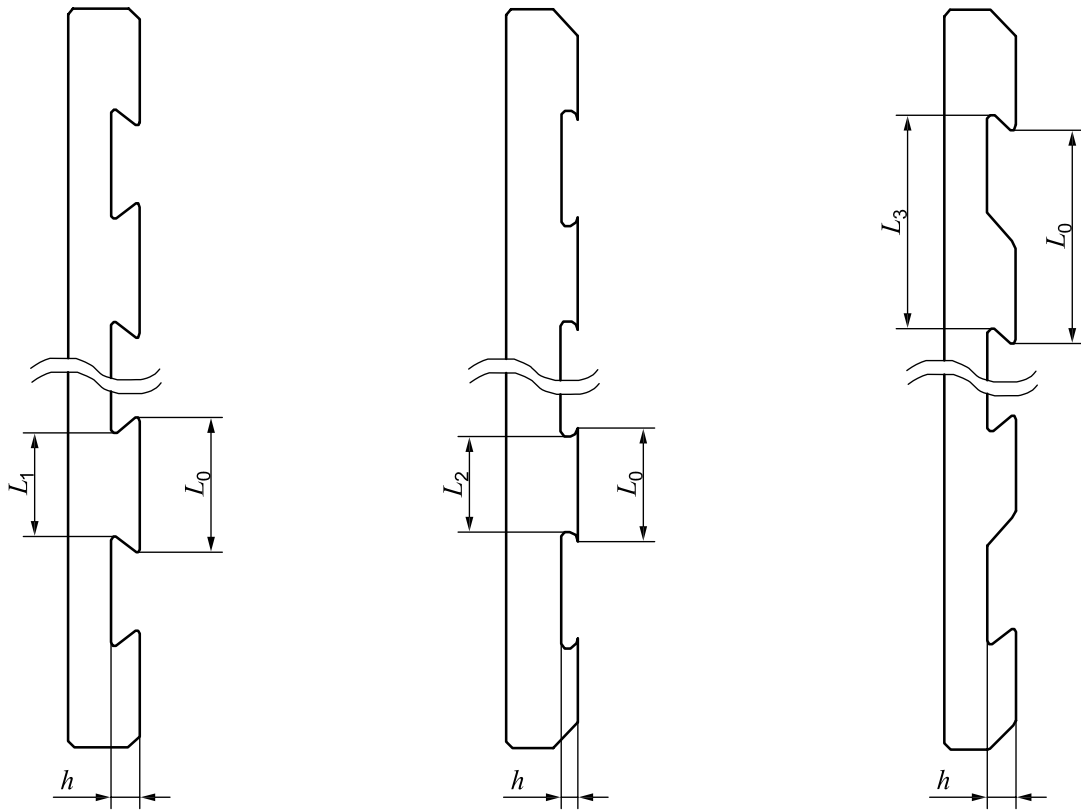

a) Example 1

b) Example 2

c) Example 3

Key

h height

L length

Figure 3 — Back feet — Examples

Annex A (normative)

Extruded ceramic tiles with low water absorption $0,5 < E_b \leq 3 \%$ Group A1_b

A.1 Requirements

Dimensional and surface quality requirements and physical and chemical properties are required to be in accordance with Table A.1.

Table A.1 — Requirements for extruded ceramic tiles — Group A1_b, $0,5 < E_b \leq 3 \%$

Dimensions and surface quality	Precision	Natural	Test
Length and width			
The manufacturer shall choose the work size as follows: a) for modular tiles in order to allow a nominal joint width of between 3 mm and 11 mm ^a ; b) for non-modular tiles so that the difference between the work size and the nominal size is not more than ± 3 mm. The deviation, in per cent, of the average size for each tile (two or four sides) from the work size, S_w	$\pm 1,0 \%$ to a maximum of ± 2 mm	$\pm 2,0 \%$ to a maximum of ± 4 mm	ISO 10545-2
The deviation, in per cent, of the average size for each tile (two or four sides) from the average size of the 10 test specimens (20 or 40 sides)	$\pm 1,0 \%$	$\pm 1,5 \%$	ISO 10545-2
Thickness			
a) The thickness shall be specified by the manufacturer ^g			
b) The deviation, in per cent, of the average thickness of each tile from the work size thickness ^g	$\pm 10 \%$	$\pm 10 \%$	ISO 10545-2
Straightness of sides^b (facial sides)			
The maximum deviation from straightness, in per cent, related to the corresponding work sizes	$\pm 0,5 \%$	$\pm 0,6 \%$	ISO 10545-2
Rectangularity^b			
The maximum deviation from rectangularity, in per cent, related to the corresponding work sizes	$\pm 1,0 \%$	$\pm 1,0 \%$	ISO 10545-2

Table A.1 (continued)

Dimensions and surface quality	Precision	Natural	Test
Surface flatness			
The maximum deviation from flatness, in per cent:			
a) centre curvature, related to diagonal calculated from the work sizes;	$\pm 0,5 \%$	$\pm 1,5 \%$	ISO 10545-2
b) edge curvature, related to the corresponding work sizes;	$\pm 0,5 \%$	$\pm 1,5 \%$	ISO 10545-2
c) warpage, related to the diagonal calculated from the work sizes.	$\pm 0,8 \%$	$\pm 1,5 \%$	ISO 10545-2
Back feet (if specified)			
a) Height, h , for tiles of surface area, A			
$49 \text{ cm}^2 \leq A < 60 \text{ cm}^2$	Minimum $h = 0,7 \text{ mm}$; Maximum $h = 3,5 \text{ mm}$		Figure 3
$A \geq 60 \text{ cm}^2$	Minimum $h = 1,5 \text{ mm}$; Maximum $h = 3,5 \text{ mm}$		Figure 3
b) Shape	Back feet as specified by the manufacturer and as shown in one of the examples in Figure 3		Figure 3
Example 1 (see Figure 3)	$L_0 - L_1 > 0$		Figure 3
Example 2 (see Figure 3)	$L_0 - L_2 > 0$		Figure 3
Example 3 (see Figure 3)	$L_0 - L_3 > 0$		Figure 3
Surface quality ^c	A minimum of 95 % of the tiles are to be free from visible defects which can impair the appearance of a major area of tiles		ISO 10545-2
Physical property	Precision	Natural	Test
Water absorption Per cent mass fraction	$0,5 < E_b \leq 3,0 \%$ Individual maximum 3,3 %	$0,5 < E_b \leq 3,0 \%$ Individual maximum 3,3 %	ISO 10545-3
Breaking strength, in Newtons			
a) Thickness $\geq 7,5 \text{ mm}$	Not less than 1 100	Not less than 1 100	ISO 10545-4
b) Thickness $< 7,5 \text{ mm}$	Not less than 600	Not less than 600	ISO 10545-4
Modulus of rupture, in Newtons per square millimetre Not applicable to tiles with breaking strength $\geq 3\ 000 \text{ N}$	Minimum 23 Individual minimum 18	Minimum 23 Individual minimum 18	ISO 10545-4
Abrasion resistance			
a) Resistance to deep abrasion of unglazed tiles: removed volume, in cubic millimetres	Maximum 275	Maximum 275	ISO 10545-6
b) Resistance to surface abrasion of glazed tiles intended for use on floors ^d	Report abrasion class and cycles passed	Report abrasion class and cycles passed	ISO 10545-7
Coefficient of linear thermal expansion ^e			
From ambient temperature to $100 \text{ }^\circ\text{C}$	Test method available	Test method available	ISO 10545-8

Table A.1 (continued)

Physical property	Precision	Natural	Test
Thermal shock resistance ^e	Test method available	Test method available	ISO 10545-9
Crazing resistance: glazed tiles ^f	Required	Required	ISO 10545-11
Frost resistance	Required	Required	ISO 10545-12
Moisture expansion, in millimetres per metre ^e	Test method available	Test method available	ISO 10545-10
Small colour differences ^e	Plain coloured tiles only where required GL: $\Delta E < 0,75$ UGL: $\Delta E < 1,0$	Plain coloured tiles only where required GL: $\Delta E < 0,75$ UGL: $\Delta E < 1,0$	ISO 10545-16
Impact resistance ^e	Test method available	Test method available	ISO 10545-5
Chemical property	Precision	Natural	Test
Resistance to staining			
a) Glazed tiles	Minimum class 3	Minimum class 3	ISO 10545-14
b) Unglazed tiles ^e	Test method available	Test method available	ISO 10545-14
Resistance to chemicals			
Resistance to low concentrations of acids and alkalis:			
a) glazed tiles;	Manufacturer is to state classification	Manufacturer is to state classification	ISO 10545-13
b) unglazed tiles.			
Resistance to high concentrations of acids and alkalis ^e	Test method available	Test method available	ISO 10545-13
Resistance to household chemicals and swimming pool salts:			
a) glazed tiles;	Minimum GB	Minimum GB	ISO 10545-13
b) unglazed tiles.	Minimum UB	Minimum UB	
Lead and cadmium release ^e	Test method available	Test method available	ISO 10545-15
<p>^a Similar joint widths shall be used to apply to traditional systems based on non-metric sizes.</p> <p>^b Not applicable to tiles having curved shapes.</p> <p>^c As a result of firing, slight variations from this standard colour are unavoidable. This does not apply to intentional irregularities of colour variation of the face of tiles (which can be unglazed, glazed or partly glazed) or to the colour variation over a tile area which is characteristic for this type of tile and desirable. Spots or coloured dots which are introduced for decorative purposes are not considered a defect.</p> <p>^d Use Annex N for the abrasion resistance classification for all glazed tiles intended for use on floors.</p> <p>^e Annex P gives information regarding requirements which are non-compulsory but which are listed as "test method available".</p> <p>^f Certain decorative effects can have a tendency to craze. These are to be identified by the manufacturer, in which case, the crazing test given in ISO 10545-11 is not applicable.</p> <p>^g Where applicable, tile thickness shall include the addition of back feet heights, as measured in accordance with Figure 3.</p>			

Annex B (normative)

Extruded ceramic tiles $3 \% < E_b \leq 6 \%$ Group All_a — Subgroup (Part) 1

B.1 Requirements

Dimensional and surface quality requirements and physical and chemical properties are required to be in accordance with Table B.1.

Table B.1 — Requirements for extruded ceramic tiles — Group All_{a-1}, $3 \% < E_b \leq 6 \%$

Dimensions and surface quality	Precision	Natural	Test
Length and width			
The manufacturer shall choose the work size as follows: a) for modular tiles in order to allow a nominal joint width of between 3 mm and 11 mm ^a ; b) for non-modular tiles so that the difference between the work size and the nominal size is not more than ± 3 mm. The deviation, in per cent, of the average size for each tile (two or four sides) from the work size, S_w	$\pm 1,25 \%$ to a maximum of ± 2 mm	$\pm 2,0 \%$ to a maximum of ± 4 mm	ISO 10545-2
The deviation, in per cent, of the average size for each tile (two or four sides) from the average size of the 10 test specimens (20 or 40 sides)	$\pm 1,0 \%$	$\pm 1,5 \%$	ISO 10545-2
Thickness			
a) The thickness shall be specified by the manufacturer ^g			
b) The deviation, in per cent, of the average thickness of each tile from the work size thickness ^g	$\pm 10 \%$	$\pm 10 \%$	ISO 10545-2
Straightness of sides^b (facial sides)			
The maximum deviation from straightness, in per cent, related to the corresponding work sizes	$\pm 0,5 \%$	$\pm 0,6 \%$	ISO 10545-2
Rectangularity^b			
The maximum deviation from rectangularity, in per cent, related to the corresponding work sizes	$\pm 1,0 \%$	$\pm 1,0 \%$	ISO 10545-2

Table B.1 (continued)

Dimensions and surface quality	Precision	Natural	Test
Surface flatness			
The maximum deviation from flatness, in per cent:			
a) centre curvature, related to diagonal calculated from the work sizes;	± 0,5 %	± 1,5 %	ISO 10545-2
b) edge curvature, related to the corresponding work sizes;	± 0,5 %	± 1,5 %	ISO 10545-2
c) warpage, related to diagonal calculated from the work sizes.	± 0,8 %	± 1,5 %	ISO 10545-2
Back feet (if specified)			
a) Height, h , for tiles of surface area, A			
$49 \text{ cm}^2 \leq A < 60 \text{ cm}^2$	Minimum $h = 0,7 \text{ mm}$; Maximum $h = 3,5 \text{ mm}$		Figure 3
$A \geq 60 \text{ cm}^2$	Minimum $h = 1,5 \text{ mm}$; Maximum $h = 3,5 \text{ mm}$		Figure 3
b) Shape	Back feet as specified by the manufacturer and as shown in one of the examples in Figure 3		Figure 3
Example 1 (see Figure 3)	$L_0 - L_1 > 0$		Figure 3
Example 2 (see Figure 3)	$L_0 - L_2 > 0$		Figure 3
Example 3 (see Figure 3)	$L_0 - L_3 > 0$		Figure 3
Surface quality ^c	A minimum of 95 % of the tiles are to be free from visible defects which can impair the appearance of a major area of tiles		ISO 10545-2
Physical property	Precision	Natural	Test
Water absorption Per cent mass fraction	$3,0 \% < E_b \leq 6,0 \%$ Individual maximum 6,5 %	$3,0 \% < E_b \leq 6,0 \%$ Individual maximum 6,5 %	ISO 10545-3
Breaking strength, in Newtons			
a) Thickness $\geq 7,5 \text{ mm}$	Not less than 950	Not less than 950	ISO 10545-4
b) Thickness $< 7,5 \text{ mm}$	Not less than 600	Not less than 600	ISO 10545-4
Modulus of rupture, in Newtons per square millimetre Not applicable to tiles with breaking strength $\geq 3\,000 \text{ N}$	Minimum 20 Individual minimum 18	Minimum 20 Individual minimum 18	ISO 10545-4
Abrasion resistance			
a) Resistance to deep abrasion of unglazed tiles: removed volume, in cubic millimetres	Maximum 393	Maximum 393	ISO 10545-6
b) Resistance to surface abrasion of glazed tiles intended for use on floors ^d	Report abrasion class and cycles passed	Report abrasion class and cycles passed	ISO 10545-7
Coefficient of linear thermal expansion ^e			
From ambient temperature to $100 \text{ }^\circ\text{C}$	Test method available	Test method available	ISO 10545-8

Table B.1 (continued)

Physical property	Precision	Natural	Test
Thermal shock resistance ^e	Test method available	Test method available	ISO 10545-9
Crazing resistance: glazed tiles ^f	Required	Required	ISO 10545-11
Frost resistance ^e	Test method available	Test method available	ISO 10545-12
Moisture expansion, in millimetres per metre ^e	Test method available	Test method available	ISO 10545-10
Small colour differences ^e	Plain coloured tiles only where required GL: $\Delta E < 0,75$ UGL: $\Delta E < 1,0$	Plain coloured tiles only where required GL: $\Delta E < 0,75$ UGL: $\Delta E < 1,0$	ISO 10545-16
Impact resistance ^e	Test method available	Test method available	ISO 10545-5
Chemical property	Precision	Natural	Test
Resistance to staining			
a) Glazed tiles	Minimum class 3	Minimum class 3	ISO 10545-14
b) Unglazed tiles ^e	Test method available	Test method available	ISO 10545-14
Resistance to chemicals			
Resistance to low concentrations of acids and alkalis:			
a) glazed tiles;	Manufacturer is to state classification	Manufacturer is to state classification	ISO 10545-13
b) unglazed tiles.			
Resistance to high concentrations of acids and alkalis ^e	Test method available	Test method available	ISO 10545-13
Resistance to household chemicals and swimming pool salts:			
a) glazed tiles;	Minimum GB	Minimum GB	ISO 10545-13
b) unglazed tiles.	Minimum UB	Minimum UB	
Lead and cadmium release ^e	Test method available	Test method available	ISO 10545-15
<p>^a Similar joint widths are to be used to apply to traditional systems based on non-metric sizes.</p> <p>^b Not applicable to tiles having curved shapes.</p> <p>^c As a result of firing, slight variations from this standard colour are unavoidable. This does not apply to intentional irregularities of colour variation of the face of tiles (which can be unglazed, glazed or partly glazed) or to the colour variation over a tile area which is characteristic for this type of tile and desirable. Spots or coloured dots which are introduced for decorative purposes are not considered a defect.</p> <p>^d Use Annex N for the abrasion resistance classification for all glazed tiles intended for use on floors.</p> <p>^e Annex P gives information regarding requirements which are non-compulsory but which are listed as "test method available".</p> <p>^f Certain decorative effects can have a tendency to craze. These are to be identified by the manufacturer, in which case the crazing test given in ISO 10545-11 is not applicable.</p> <p>^g Where applicable, tile thickness shall include the addition of back feet heights, as measured in accordance with Figure 3.</p>			

Annex C (normative)

Extruded ceramic tiles $3\% < E_b \leq 6\%$ Group All_{a-2} — Subgroup (Part) 2

C.1 Requirements

Dimensional and surface quality requirements and physical and chemical properties are required to be in accordance with Table C.1.

Table C.1 — Requirements for extruded ceramic tiles — Group All_{a-2}, $3\% < E_b \leq 6\%$

Dimensions and surface quality	Precision	Natural	Test
Length and width			
The manufacturer shall choose the work size as follows: a) for modular tiles in order to allow a nominal joint width of between 3 mm and 11 mm ^a ; b) for non-modular tiles so that the difference between the work size and the nominal size is not more than ± 3 mm. The deviation, in per cent, of the average size for each tile (two or four sides) from the work size, S_w	$\pm 1,5\%$ to a maximum of ± 2 mm	$\pm 2,0\%$ to a maximum of ± 4 mm	ISO 10545-2
The deviation, in per cent, of the average size for each tile (two or four sides) from the average size of the 10 test specimens (20 or 40 sides)	$\pm 1,5\%$	$\pm 1,5\%$	ISO 10545-2
Thickness			
a) The thickness shall be specified by the manufacturer ^g			
b) The deviation, in per cent, of the average thickness of each tile from the work size thickness ^g	$\pm 10\%$	$\pm 10\%$	ISO 10545-2
Straightness of sides^b (facial sides)			
The maximum deviation from straightness, in per cent, related to the corresponding work sizes	$\pm 1,0\%$	$\pm 1,0\%$	ISO 10545-2
Rectangularity^b			
The maximum deviation from rectangularity, in per cent related to the corresponding work sizes	$\pm 1,0\%$	$\pm 1,0\%$	ISO 10545-2

Table C.1 (continued)

Dimensions and surface quality	Precision	Natural	Test
Surface flatness			
The maximum deviation from flatness, in per cent:			
a) centre curvature, related to diagonal calculated from the work sizes;	$\pm 1,0 \%$	$\pm 1,5 \%$	ISO 10545-2
b) edge curvature, related to the corresponding work sizes;	$\pm 1,0 \%$	$\pm 1,5 \%$	ISO 10545-2
c) warpage, related to diagonal calculated from the work sizes.	$\pm 1,5 \%$	$\pm 1,5 \%$	ISO 10545-2
Back feet (if specified)			
a) Height, h , for tiles of surface area, A			
$49 \text{ cm}^2 \leq A < 60 \text{ cm}^2$	Minimum $h = 0,7 \text{ mm}$; Maximum $h = 3,5 \text{ mm}$		Figure 3
$A \geq 60 \text{ cm}^2$	Minimum $h = 1,5 \text{ mm}$; Maximum $h = 3,5 \text{ mm}$		Figure 3
b) Shape	Back feet as specified by the manufacturer and as shown in one of the examples in Figure 3		Figure 3
Example 1 (see Figure 3)	$L_0 - L_1 > 0$		Figure 3
Example 2 (see Figure 3)	$L_0 - L_2 > 0$		Figure 3
Example 3 (see Figure 3)	$L_0 - L_3 > 0$		Figure 3
Surface quality ^c	A minimum of 95 % of the tiles are to be free from visible defects which can impair the appearance of a major area of tiles		ISO 10545-2
Physical property	Precision	Natural	Test
Water absorption Per cent mass fraction	$3,0 \% < E_b \leq 6,0 \%$ Individual maximum 6,5 %	$3,0 \% < E_b \leq 6,0 \%$ Individual maximum 6,5 %	ISO 10545-3
Breaking strength, in Newtons			
a) Thickness $\geq 7,5 \text{ mm}$	Not less than 800	Not less than 800	ISO 10545-4
b) Thickness $< 7,5 \text{ mm}$	Not less than 600	Not less than 600	ISO 10545-4
Modulus of rupture, in Newtons per square millimetre Not applicable to tiles with breaking strength $\geq 3\,000 \text{ N}$	Minimum 13 Individual minimum 11	Minimum 13 Individual minimum 11	ISO 10545-4
Abrasion resistance			
a) Resistance to deep abrasion of unglazed tiles: removed volume, in cubic millimetres	Maximum 541	Maximum 541	ISO 10545-6
b) Resistance to surface abrasion of glazed tiles intended for use on floors ^d	Report abrasion class and cycles passed	Report abrasion class and cycles passed	ISO 10545-7
Coefficient of linear thermal expansion ^e			
From ambient temperature to $100 \text{ }^\circ\text{C}$	Test method available	Test method available	ISO 10545-8

Table C.1 (continued)

Physical property	Precision	Natural	Test
Thermal shock resistance ^e	Test method available	Test method available	ISO 10545-9
Crazing resistance: glazed tiles ^f	Required	Required	ISO 10545-11
Frost resistance ^e	Test method available	Test method available	ISO 10545-12
Moisture expansion, in millimetres per metre ^e	Test method available	Test method available	ISO 10545-10
Small colour differences ^e	Plain coloured tiles only where required GL: $\Delta E < 0,75$ UGL: $\Delta E < 1,0$	Plain coloured tiles only where required GL: $\Delta E < 0,75$ UGL: $\Delta E < 1,0$	ISO 10545-16
Impact resistance ^e	Test method available	Test method available	ISO 10545-5
Chemical property	Precision	Natural	Test
Resistance to staining			
a) Glazed tiles	Minimum class 3	Minimum class 3	ISO 10545-14
b) Unglazed tiles ^e	Test method available	Test method available	ISO 10545-14
Resistance to chemicals			
Resistance to low concentrations of acids and alkalis:			
a) glazed tiles; b) unglazed tiles.	Manufacturer is to state classification	Manufacturer is to state classification	ISO 10545-13
Resistance to high concentrations of acids and alkalis ^e	Test method available	Test method available	ISO 10545-13
Resistance to household chemicals and swimming pool salts:			
a) glazed tiles; b) unglazed tiles.	Minimum GB Minimum UB	Minimum GB Minimum UB	ISO 10545-13
Lead and cadmium release^e	Test method available	Test method available	ISO 10545-15
<p>a Similar joint widths are to be used to apply to traditional systems based on non-metric sizes.</p> <p>b Not applicable to tiles having curved shapes.</p> <p>c As a result of firing, slight variations from this standard colour are unavoidable. This does not apply to intentional irregularities of colour variation of the face of tiles (which can be unglazed, glazed or partly glazed) or to the colour variation over a tile area which is characteristic for this type of tile and desirable. Spots or coloured dots which are introduced for decorative purposes are not considered a defect.</p> <p>d Use Annex N for the abrasion resistance classification for all glazed tiles intended for use on floors.</p> <p>e Annex P gives information regarding requirements which are non-compulsory but which are listed as "test method available".</p> <p>f Certain decorative effects can have a tendency to craze. These are to be identified by the manufacturer, in which case the crazing test given in ISO 10545-11 is not applicable.</p> <p>g Where applicable, tile thickness shall include the addition of back feet heights, as measured in accordance with Figure 3.</p>			

Annex D (normative)

Extruded ceramic tiles $6\% < E_b \leq 10\%$ Group Allb — Subgroup (Part) 1

D.1 Requirements

Dimensional and surface quality requirements and physical and chemical properties are required to be in accordance with Table D.1.

Table D.1 — Requirements for extruded ceramic tiles — Group Allb-1, $6\% < E_b \leq 10\%$

Dimensions and surface quality	Precision	Natural	Test
Length and width			
The manufacturer shall choose the work size as follows: a) for modular tiles in order to allow a nominal joint width of between 3 mm and 11 mm ^a ; b) for non-modular tiles so that the difference between the work size and the nominal size is not more than ± 3 mm. The deviation, in per cent, of the average size for each tile (two or four sides) from the work size, S_w	$\pm 2,0\%$ to a maximum of ± 2 mm	$\pm 2,0\%$ to a maximum of ± 4 mm	ISO 10545-2
The deviation, in per cent, of the average size for each tile (two or four sides) from the average size of the 10 test specimens (20 or 40 sides)	$\pm 1,5\%$	$\pm 1,5\%$	ISO 10545-2
Thickness			
a) The thickness shall be specified by the manufacturer ⁹			
b) The deviation, in per cent, of the average thickness of each tile from the work size thickness ⁹	$\pm 10\%$	$\pm 10\%$	ISO 10545-2
Straightness of sides^b (facial sides)			
The maximum deviation from straightness, in per cent, related to the corresponding work sizes	$\pm 1,0\%$	$\pm 1,0\%$	ISO 10545-2
Rectangularity^b			
The maximum deviation from rectangularity, in per cent, related to the corresponding work sizes	$\pm 1,0\%$	$\pm 1,0\%$	ISO 10545-2

Table D.1 (continued)

Dimensions and surface quality	Precision	Natural	Test
Surface flatness			
The maximum deviation from flatness, in per cent:			
a) centre curvature, related to diagonal calculated from the work sizes;	± 1,0 %	± 1,5 %	ISO 10545-2
b) edge curvature, related to the corresponding work sizes;	± 1,0 %	± 1,5 %	ISO 10545-2
c) warpage, related to diagonal calculated from the work sizes.	± 1,5 %	± 1,5 %	ISO 10545-2
Back feet (if specified)			
a) Height, <i>h</i> , for tiles of surface area, <i>A</i>			
49 cm ² ≤ <i>A</i> < 60 cm ²	Minimum <i>h</i> = 0,7 mm; Maximum <i>h</i> = 3,5 mm		Figure 3
<i>A</i> ≥ 60 cm ²	Minimum <i>h</i> = 1,5 mm; Maximum <i>h</i> = 3,5 mm		Figure 3
b) Shape	Back feet as specified by the manufacturer and as shown in one of the examples in Figure 3		Figure 3
Example 1 (see Figure 3)	$L_0 - L_1 > 0$		Figure 3
Example 2 (see Figure 3)	$L_0 - L_2 > 0$		Figure 3
Example 3 (see Figure 3)	$L_0 - L_3 > 0$		Figure 3
Surface quality ^c	A minimum of 95 % of the tiles are to be free from visible defects which can impair the appearance of a major area of tiles		ISO 10545-2
Physical property	Precision	Natural	Test
Water absorption Per cent mass fraction	6 % < E_b ≤ 10 % Individual maximum 11 %	6 % < E_b ≤ 10 % Individual maximum 11 %	ISO 10545-3
Breaking strength, in Newtons	Not less than 900	Not less than 900	ISO 10545-4
Modulus of rupture, in Newtons per square millimetre Not applicable to tiles with breaking strength ≥ 3 000 N	Minimum 17,5 Individual minimum 15	Minimum 17,5 Individual minimum 15	ISO 10545-4
Abrasion resistance			
a) Resistance to deep abrasion of unglazed tiles: removed volume, in cubic millimetres	Maximum 649	Maximum 649	ISO 10545-6
b) Resistance to surface abrasion of glazed tiles intended for use on floors ^d	Report abrasion class and cycles passed	Report abrasion class and cycles passed	ISO 10545-7
Coefficient of linear thermal expansion ^e			
From ambient temperature to 100 °C	Test method available	Test method available	ISO 10545-8

Table D.1 (continued)

Dimensions and surface quality	Precision	Natural	Test
Thermal shock resistance ^e	Test method available	Test method available	ISO 10545-9
Crazing resistance: glazed tiles ^f	Required	Required	ISO 10545-11
Frost resistance ^e	Test method available	Test method available	ISO 10545-12
Moisture expansion, in millimetres per metre	Test method available	Test method available	ISO 10545-10
Small colour differences ^e	Plain coloured tiles only where required GL: $\Delta E < 0,75$ UGL: $\Delta E < 1,0$	Plain coloured tiles only where required GL: $\Delta E < 0,75$ UGL: $\Delta E < 1,0$	ISO 10545-16
Impact resistance ^e	Test method available	Test method available	ISO 10545-5
Chemical property	Precision	Natural	Test
Resistance to staining			
a) Glazed tiles	Minimum class 3	Minimum class 3	ISO 10545-14
b) Unglazed tiles ^e	Test method available	Test method available	ISO 10545-14
Resistance to chemicals			
Resistance to low concentrations of acids and alkalis:			
a) glazed tiles;	Manufacturer is to state classification	Manufacturer is to state classification	ISO 10545-13
b) unglazed tiles.			
Resistance to high concentrations of acids and alkalis ^e	Test method available	Test method available	ISO 10545-13
Resistance to household chemicals and swimming pool salts:			
a) glazed tiles;	Minimum GB	Minimum GB	ISO 10545-13
b) unglazed tiles.	Minimum UB	Minimum UB	
Lead and cadmium release ^e	Test method available	Test method available	ISO 10545-15
<p>^a Similar joint widths are to be used to apply to traditional systems based on non-metric sizes.</p> <p>^b Not applicable to tiles having curved shapes.</p> <p>^c As a result of firing, slight variations from this standard colour are unavoidable. This does not apply to intentional irregularities of colour variation of the face of tiles (which can be unglazed, glazed or partly glazed) or to the colour variation over a tile area which is characteristic for this type of tile and desirable. Spots or coloured dots which are introduced for decorative purposes are not considered a defect.</p> <p>^d Use Annex N for the abrasion resistance classification for all glazed tiles intended for use on floors.</p> <p>^e Annex P gives information regarding requirements which are non-compulsory but which are listed as "test method available".</p> <p>^f Certain decorative effects can have a tendency to craze. These are to be identified by the manufacturer, in which case the crazing test given in ISO 10545-11 is not applicable.</p> <p>^g Where applicable, tile thickness shall include the addition of back feet heights, as measured in accordance with Figure 3.</p>			

Annex E (normative)

Extruded ceramic tiles $6\% < E_b \leq 10\%$ Group All_b — Subgroup (Part) 2

E.1 Requirements

Dimensional and surface quality requirements and physical and chemical properties are required to be in accordance with Table E.1.

Table E.1 — Requirements for extruded ceramic tiles — Group All_{b-2}, $6\% < E_b \leq 10\%$

Dimensions and surface quality	Precision	Natural	Test
Length and width			
The manufacturer shall choose the work size as follows: a) for modular tiles in order to allow a nominal joint width of between 3 mm and 11 mm ^a ; b) or non-modular tiles so that the difference between the work size and the nominal size is not more than ± 3 mm. The deviation, in per cent, of the average size for each tile (two or four sides) from the work size, S_w	$\pm 2,0\%$ to a maximum of ± 2 mm	$\pm 2,0\%$ to a maximum of ± 4 mm	ISO 10545-2
The deviation, in per cent, of the average size for each tile (two or four sides) from the average size of the 10 test specimens (20 or 40 sides)	$\pm 1,5\%$	$\pm 1,5\%$	ISO 10545-2
Thickness			
a) The thickness shall be specified by the manufacturer ^g			
b) The deviation, in per cent, of the average thickness of each tile from the work size thickness ^g	$\pm 10\%$	$\pm 10\%$	ISO 10545-2
Straightness of sides^b (facial sides)			
The maximum deviation from straightness, in per cent, related to the corresponding work sizes	$\pm 1,0\%$	$\pm 1,0\%$	ISO 10545-2
Rectangularity^b			
The maximum deviation from rectangularity, in per cent, related to the corresponding work sizes	$\pm 1,0\%$	$\pm 1,0\%$	ISO 10545-2

Table E.1 (continued)

Dimensions and surface quality	Precision	Natural	Test
Surface flatness			
The maximum deviation from flatness, in per cent:			
a) centre curvature, related to diagonal calculated from the work sizes;	$\pm 1,0 \%$	$\pm 1,5 \%$	ISO 10545-2
b) edge curvature, related to the corresponding work sizes;	$\pm 1,0 \%$	$\pm 1,5 \%$	ISO 10545-2
c) warpage, related to diagonal calculated from the work sizes.	$\pm 1,5 \%$	$\pm 1,5 \%$	ISO 10545-2
Back feet (if specified)			
a) Height, h , for tiles of surface area, A			
$49 \text{ cm}^2 \leq A < 60 \text{ cm}^2$	Minimum $h = 0,7 \text{ mm}$; Maximum $h = 3,5 \text{ mm}$		Figure 3
$A \geq 60 \text{ cm}^2$	Minimum $h = 1,5 \text{ mm}$; Maximum $h = 3,5 \text{ mm}$		Figure 3
b) Shape	Back feet as specified by the manufacturer and as shown in one of the examples in Figure 3		Figure 3
Example 1 (see Figure 3)	$L_0 - L_1 > 0$		Figure 3
Example 2 (see Figure 3)	$L_0 - L_2 > 0$		Figure 3
Example 3 (see Figure 3)	$L_0 - L_3 > 0$		Figure 3
Surface quality ^c	A minimum of 95 % of the tiles are to be free from visible defects which can impair the appearance of a major area of tiles		ISO 10545-2
Physical property	Precision	Natural	Test
Water absorption Per cent mass fraction	$6 \% < E_b \leq 10 \%$ Individual maximum 11 %	$6 \% < E_b \leq 10 \%$ Individual maximum 11 %	ISO 10545-3
Breaking strength, in Newtons	Not less than 750	Not less than 750	ISO 10545-4
Modulus of rupture, in Newtons per square millimetre Not applicable to tiles with breaking strength $\geq 3\,000 \text{ N}$.	Minimum 9 Individual minimum 8	Minimum 9 Individual minimum 8	ISO 10545-4
Abrasion resistance			
a) Resistance to deep abrasion of unglazed tiles: removed volume, in cubic millimetres	Maximum 1 062	Maximum 1 062	ISO 10545-6
b) Resistance to surface abrasion of glazed tiles intended for use on floors ^d	Report abrasion class and cycles passed	Report abrasion class and cycles passed	ISO 10545-7
Coefficient of linear thermal expansion ^e			
From ambient temperature to $100 \text{ }^\circ\text{C}$	Test method available	Test method available	ISO 10545-8

Table E.1 (continued)

Physical property	Precision	Natural	Test
Thermal shock resistance ^e	Test method available	Test method available	ISO 10545-9
Crazing resistance: glazed tiles ^f	Required	Required	ISO 10545-11
Frost resistance ^e	Test method available	Test method available	ISO 10545-12
Moisture expansion, in millimetres per metre	Test method available	Test method available	ISO 10545-10
Small colour differences ^e	Plain coloured tiles only where required GL: $\Delta E < 0,75$ UGL: $\Delta E < 1,0$	Plain coloured tiles only where required GL: $\Delta E < 0,75$ UGL: $\Delta E < 1,0$	ISO 10545-16
Impact resistance ^e	Test method available	Test method available	ISO 10545-5
Chemical property	Precision	Natural	Test
Resistance to staining			
a) Glazed tiles	Minimum class 3	Minimum class 3	ISO 10545-14
b) Unglazed tiles ^e	Test method available	Test method available	ISO 10545-14
Resistance to chemicals			
Resistance to low concentrations of acids and alkalis:			
a) glazed tiles; b) unglazed tiles.	Manufacturer is to state classification	Manufacturer is to state classification	ISO 10545-13
Resistance to high concentrations of acids and alkalis ^e	Test method available	Test method available	ISO 10545-13
Resistance to household chemicals and swimming pool salts:			
a) glazed tiles; b) unglazed tiles.	Minimum GB Minimum UB	Minimum GB Minimum UB	ISO 10545-13
Lead and cadmium release ^e	Test method available	Test method available	ISO 10545-15
<p>a Similar joint widths are to be used to apply to traditional systems based on non-metric sizes.</p> <p>b Not applicable to tiles having curved shapes.</p> <p>c As a result of firing, slight variations from this standard colour are unavoidable. This does not apply to intentional irregularities of colour variation of the face of tiles (which can be unglazed, glazed or partly glazed) or to the colour variation over a tile area which is characteristic for this type of tile and desirable. Spots or coloured dots which are introduced for decorative purposes are not considered a defect.</p> <p>d Use Annex N for the abrasion resistance classification for all glazed tiles intended for use on floors.</p> <p>e Annex P gives information regarding requirements which are non-compulsory but which are listed as "test method available".</p> <p>f Certain decorative effects can have a tendency to craze. These are to be identified by the manufacturer, in which case the crazing test given in ISO 10545-11 is not applicable.</p> <p>g Where applicable, tile thickness shall include the addition of back feet heights, as measured in accordance with Figure 3.</p>			

Annex F (normative)

Extruded ceramic tiles

$E_b > 10 \%$
Group AIII

F.1 Requirements

Dimensional and surface quality requirements and physical and chemical properties are required to be in accordance with Table F.1.

Table F.1 — Requirements for extruded ceramic tiles — Group AIII, $E_b > 10 \%$

Dimensions and surface quality	Precision	Natural	Test
Length and width			
The manufacturer shall choose the work size as follows: a) for modular tiles in order to allow a nominal joint width of between 3 mm and 11 mm ^a ; b) for non-modular tiles so that the difference between the work size and the nominal size is not more than ± 3 mm. The deviation, in per cent, of the average size for each tile (two or four sides) from the work size, S_w	$\pm 2,0 \%$ to a maximum of ± 2 mm	$\pm 2,0 \%$ to a maximum of ± 4 mm	ISO 10545-2
The deviation, in per cent, of the average size for each tile (two or four sides) from the average size of the 10 test specimens (20 or 40 sides)	$\pm 1,5 \%$	$\pm 1,5 \%$	ISO 10545-2
Thickness			
a) The thickness shall be specified by the manufacturer ⁹			
b) The deviation, in per cent, of the average thickness of each tile from the work size thickness ⁹	$\pm 10 \%$	$\pm 10 \%$	ISO 10545-2
Straightness of sides^b (facial sides)			
The maximum deviation from straightness, in per cent, related to the corresponding work sizes	$\pm 1,0 \%$	$\pm 1,0 \%$	ISO 10545-2
Rectangularity^b			
The maximum deviation from rectangularity, in per cent, related to the corresponding work sizes	$\pm 1,0 \%$	$\pm 1,0 \%$	ISO 10545-2

Table F.1 (continued)

Dimensions and surface quality	Precision	Natural	Test
Surface flatness			
The maximum deviation from flatness, in per cent:			
a) centre curvature, related to diagonal calculated from the work sizes;	± 1,0 %	± 1,5 %	ISO 10545-2
b) edge curvature, related to the corresponding work sizes;	± 1,0 %	± 1,5 %	ISO 10545-2
c) warpage, related to diagonal calculated from the work sizes.	± 1,5 %	± 1,5 %	ISO 10545-2
Back feet (if specified)			
a) Height, <i>h</i> , for tiles of surface area, <i>A</i>			
49 cm ² ≤ <i>A</i> < 60 cm ²	Minimum <i>h</i> = 0,7 mm; Maximum <i>h</i> = 3,5 mm		Figure 3
<i>A</i> ≥ 60 cm ²	Minimum <i>h</i> = 1,5 mm; Maximum <i>h</i> = 3,5 mm		Figure 3
b) Shape	Back feet as specified by the manufacturer and as shown in one of the examples in Figure 3		Figure 3
Example 1 (see Figure 3)	$L_0 - L_1 > 0$		Figure 3
Example 2 (see Figure 3)	$L_0 - L_2 > 0$		Figure 3
Example 3 (see Figure 3)	$L_0 - L_3 > 0$		Figure 3
Surface quality ^c	A minimum of 95 % of the tiles are to be free from visible defects which can impair the appearance of a major area of tiles		ISO 10545-2
Physical property	Precision	Natural	Test
Water absorption Per cent mass fraction	$E_b > 10 \%$	$E_b > 10 \%$	ISO 10545-3
Breaking strength, in Newtons	Not less than 600	Not less than 600	ISO 10545-4
Modulus of rupture, in Newtons per square millimetre Not applicable to tiles with breaking strength ≥ 3 000 N	Minimum 8 Individual minimum 7	Minimum 8 Individual minimum 7	ISO 10545-4
Abrasion resistance			
a) Resistance to deep abrasion of unglazed tiles: removed volume, in cubic millimetres	Maximum 2 365	Maximum 2 365	ISO 10545-6
b) Resistance to surface abrasion of glazed tiles intended for use on floors ^d	Report abrasion class and cycles passed	Report abrasion class and cycles passed	ISO 10545-7
Coefficient of linear thermal expansion ^e			
From ambient temperature to 100 °C	Test method available	Test method available	ISO 10545-8

Table F.1 (continued)

Physical property	Precision	Natural	Test
Thermal shock resistance ^e	Test method available	Test method available	ISO 10545-9
Crazing resistance: glazed tiles ^f	Required	Required	ISO 10545-11
Frost resistance ^e	Test method available	Test method available	ISO 10545-12
Moisture expansion, in millimetres per metre ^e	Test method available	Test method available	ISO 10545-10
Small colour differences ^e	Plain coloured tiles only where required GL: $\Delta E < 0,75$ UGL: $\Delta E < 1,0$	Plain coloured tiles only where required GL: $\Delta E < 0,75$ UGL: $\Delta E < 1,0$	ISO 10545-16
Impact resistance ^e	Test method available	Test method available	ISO 10545-5
Chemical property	Precision	Natural	Test
Resistance to staining			
a) Glazed tiles	Minimum class 3	Minimum class 3	ISO 10545-14
b) Unglazed tiles ^e	Test method available	Test method available	ISO 10545-14
Resistance to chemicals			
Resistance to low concentrations of acids and alkalis:			
a) glazed tiles;	Manufacturer is to state classification	Manufacturer is to state classification	ISO 10545-13
b) unglazed tiles.			
Resistance to high concentrations of acids and alkalis ^e	Test method available	Test method available	ISO 10545-13
Resistance to household chemicals and swimming pool salts:			
a) glazed tiles;	Minimum GB	Minimum GB	ISO 10545-13
b) unglazed tiles.	Minimum UB	Minimum UB	
Lead and cadmium release ^e	Test method available	Test method available	ISO 10545-15
<p>^a Similar joint widths are to be used to apply to traditional systems based on non-metric sizes.</p> <p>^b Not applicable to tiles having curved shapes.</p> <p>^c As a result of firing, slight variations from this standard colour are unavoidable. This does not apply to intentional irregularities of colour variation of the face of tiles (which can be unglazed, glazed or partly glazed) or to the colour variation over a tile area which is characteristic for this type of tile and desirable. Spots or coloured dots which are introduced for decorative purposes are not considered a defect.</p> <p>^d Use Annex N for the abrasion resistance classification for all glazed tiles intended for use on floors.</p> <p>^e Annex P gives information regarding requirements which are non-compulsory but which are listed as "test method available".</p> <p>^f Certain decorative effects can have a tendency to craze. These are to be identified by the manufacturer, in which case the crazing test given in ISO 10545-11 is not applicable.</p> <p>^g Where applicable, tile thickness shall include the addition of back feet heights, as measured in accordance with Figure 3.</p>			

Annex G (normative)

Dry-pressed ceramic tiles with low water absorption

$$E_b \leq 0,5 \%$$

Group BI_a

G.1 Requirements

Dimensional and surface quality requirements and physical and chemical properties are required to be in accordance with Table G.1.

**Table G.1 — Requirements for dry-pressed ceramic tiles with low water absorption —
Group BI_a, $E_b \leq 0,5 \%$**

Dimensions and surface quality	Nominal size N			Test
	7 cm ≤ N < 15 cm	N ≥ 15 cm		
	mm	%	mm	
Length and width				
The manufacturer shall choose the work size as follows: a) for modular tiles in order to allow a nominal joint width of between 2 mm and 5 mm ^a ; b) for non-modular tiles so that the difference between the work size and the nominal size is not more than ± 2 % (max. ± 5 mm). The deviation, in per cent, of the average size for each tile (two or four sides) from the work size, S_w	± 0,9	± 0,6	± 2,0	ISO 10545-2
Thickness				
a) The thickness shall be specified by the manufacturer ^h				
b) The deviation, in per cent, of the average thickness of each tile from the work size thickness ^h	± 0,5	± 5	± 0,5	ISO 10545-2
Straightness of sides^b (facial sides)				
The maximum deviation from straightness, in per cent, related to the corresponding work sizes	± 0,75	± 0,5	± 1,5	ISO 10545-2
Rectangularity^b				
The maximum deviation from rectangularity, in per cent, related to the corresponding work sizes	± 0,75	± 0,5	± 2,0	ISO 10545-2

Table G.1 (continued)

Dimensions and surface quality	Nominal size N			Test
	7 cm ≤ N < 15 cm	N ≥ 15 cm		
	mm	%	mm	
Surface flatness				
The maximum deviation from flatness, in per cent:				
a) centre curvature, related to diagonal calculated from the work sizes;	± 0,75	± 0,5	± 2,0	ISO 10545-2
b) edge curvature, related to the corresponding work sizes;	± 0,75	± 0,5	± 2,0	ISO 10545-2
c) warpage, related to diagonal calculated from the work sizes.	± 0,75	± 0,5	± 2,0	ISO 10545-2
Back feet (if specified)				
a) Height, <i>h</i> , for tiles of surface area, <i>A</i>				
49 cm ² ≤ <i>A</i> < 60 cm ²	Minimum <i>h</i> = 0,7 mm; Maximum <i>h</i> = 3,5 mm			Figure 3
<i>A</i> ≥ 60 cm ²	Minimum <i>h</i> = 1,5 mm; Maximum <i>h</i> = 3,5 mm			Figure 3
b) Shape	Back feet as specified by the manufacturer and as shown in one of the examples in Figure 3			Figure 3
Example 1 (see Figure 3)	$L_0 - L_1 > 0$			Figure 3
Example 2 (see Figure 3)	$L_0 - L_2 > 0$			Figure 3
Example 3 (see Figure 3)	$L_0 - L_3 > 0$			Figure 3
Surface quality ^c	A minimum of 95 % of the tiles are to be free from visible defects which can impair the appearance of a major area of tiles			ISO 10545-2
Physical property	Requirements			Test
Water absorption Per cent mass fraction ^g	$E_b \leq 0,5 \%$ Individual maximum 0,6 %			ISO 10545-3
Breaking strength, in Newtons				
a) Thickness ≥ 7,5 mm	Not less than 1 300			ISO 10545-4
b) Thickness < 7,5 mm	Not less than 700			ISO 10545-4
Modulus of rupture, in Newtons per square millimetre Not applicable to tiles with breaking strength ≥ 3 000 N	Minimum 35 Individual minimum 32			ISO 10545-4
Abrasion resistance				
a) Resistance to deep abrasion of unglazed tiles: removed volume, in cubic millimetres	Maximum 175			ISO 10545-6
b) Resistance to surface abrasion of glazed tiles intended for use on floors ^d	Report abrasion class and cycles passed			ISO 10545-7
Coefficient of linear thermal expansion ^e				
From ambient temperature to 100 °C	Test method available			ISO 10545-8
Thermal shock resistance ^e	Test method available			ISO 10545-9

Table G.1 (continued)

Physical property	Requirements	Test
Crazing resistance: glazed tiles ^f	Required	ISO 10545-11
Frost resistance	Required	ISO 10545-12
Moisture expansion, in millimetres per metre ^e	Test method available	ISO 10545-10
Small colour differences ^e	Plain coloured tiles only where required GL: $\Delta E < 0,75$ UGL: $\Delta E < 1,0$	ISO 10545-16
Impact resistance ^e	Test method available	ISO 10545-5
Chemical property	Requirements	Test
Resistance to staining		
a) Glazed tiles	Minimum class 3	ISO 10545-14
b) Unglazed tiles ^e	Test method available	ISO 10545-14
Resistance to chemicals		
Resistance to low concentrations of acids and alkalis:		
a) glazed tiles;	Manufacturer is to state classification	ISO 10545-13
b) unglazed tiles.	Manufacturer is to state classification	ISO 10545-13
Resistance to high concentrations of acids and alkalis ^e	Test method available	ISO 10545-13
Resistance to household chemicals and swimming pool salts:		
a) glazed tiles;	Minimum GB	ISO 10545-13
b) unglazed tiles.	Minimum UB	
Lead and cadmium release ^e	Test method available	ISO 10545-15
<p>^a Similar joint widths are to be used to apply to traditional systems based on non-metric sizes.</p> <p>^b Not applicable to tiles having curved shapes.</p> <p>^c As a result of firing, slight variations from this standard colour are unavoidable. This does not apply to intentional irregularities of colour variation of the face of tiles (which can be unglazed, glazed or partly glazed) or to the colour variation over a tile area which is characteristic for this type of tile and desirable. Spots or coloured dots which are introduced for decorative purposes are not considered a defect.</p> <p>^d Use Annex N for the abrasion resistance classification for all glazed tiles intended for use on floors.</p> <p>^e Annex P gives information regarding requirements which are non-compulsory but which are listed as "test method available".</p> <p>^f Certain decorative effects can have a tendency to craze. These are to be identified by the manufacturer, in which case the crazing test given in ISO 10545-11 is not applicable.</p> <p>^g A fully vitrified tile is a tile with water absorption of a maximum individual value of 0,5 % (sometimes described as impervious porcelain tile).</p> <p>^h Where applicable, tile thickness shall include the addition of back feet heights, as measured in accordance with Figure 3.</p>		

Annex H (normative)

Dry-pressed ceramic tiles with low water absorption $0,5 \% < E_b \leq 3 \%$ Group BI_b

H.1 Requirements

Dimensional and surface quality requirements and physical and chemical properties are required to be in accordance with Table H.1.

**Table H.1 — Requirements for dry-pressed ceramic tiles with low water absorption —
Group BI_b, $0,5 \% < E_b \leq 3 \%$**

Dimensions and surface quality	Nominal size N			Test
	7 cm ≤ N < 15 cm	N ≥ 15 cm		
	mm	%	mm	
Length and width				
The manufacturer shall choose the work size as follows: a) for modular tiles in order to allow a nominal joint width of between 2 mm and 5 mm ^a ; b) for non-modular tiles so that the difference between the work size and the nominal size is not more than ± 2 % (max. ± 5 mm).				
The deviation, in per cent, of the average size for each tile (two or four sides) from the work size, S_w	± 0,9	± 0,6	± 2,0	ISO 10545-2
Thickness				
a) The thickness shall be specified by the manufacturer ⁹				
b) The deviation, in per cent, of the average thickness of each tile from the work size thickness ⁹	± 0,5	± 5	± 0,5	ISO 10545-2
Straightness of sides^b (facial sides)				
The maximum deviation from straightness, in per cent, related to the corresponding work sizes	± 0,75	± 0,5	± 1,5	ISO 10545-2
Rectangularity^b				
The maximum deviation from rectangularity, in per cent, related to the corresponding work sizes	± 0,75	± 0,5	± 2,0	ISO 10545-2

Table H.1 (continued)

Dimensions and surface quality	Nominal size N			Test
	7 cm ≤ N < 15 cm	N ≥ 15 cm		
	mm	%	mm	
Surface flatness				
The maximum deviation from flatness, in per cent:				
a) centre curvature, related to diagonal calculated from the work sizes;	± 0,75	± 0,5	± 2,0	ISO 10545-2
b) edge curvature, related to the corresponding work sizes;	± 0,75	± 0,5	± 2,0	ISO 10545-2
c) warpage, related to diagonal calculated from the work sizes.	± 0,75	± 0,5	± 2,0	ISO 10545-2
Back feet (if specified)				
a) Height, <i>h</i> , for tiles of surface area, <i>A</i>				
49 cm ² ≤ <i>A</i> < 60 cm ²	Minimum <i>h</i> = 0,7 mm; Maximum <i>h</i> = 3,5 mm			Figure 3
<i>A</i> ≥ 60 cm ²	Minimum <i>h</i> = 1,5 mm; Maximum <i>h</i> = 3,5 mm			Figure 3
b) Shape	Back feet as specified by the manufacturer and as shown in one of the examples in Figure 3			Figure 3
Example 1 (see Figure 3)	$L_0 - L_1 > 0$			Figure 3
Example 2 (see Figure 3)	$L_0 - L_2 > 0$			Figure 3
Example 3 (see Figure 3)	$L_0 - L_3 > 0$			Figure 3
Surface quality ^c	A minimum of 95 % of the tiles are to be free from visible defects which can impair the appearance of a major area of tiles			ISO 10545-2
Physical property	Requirements			Test
Water absorption Per cent mass fraction	0,5 % < <i>E_b</i> ≤ 3 % Individual maximum 3,3 %			ISO 10545-3
Breaking strength, in Newtons				
a) Thickness ≥ 7,5 mm	Not less than 1 100			ISO 10545-4
b) Thickness < 7,5 mm	Not less than 700			ISO 10545-4
Modulus of rupture, in Newtons per square millimetre Not applicable to tiles with breaking strength ≥ 3 000 N	Minimum 30 Individual minimum 27			ISO 10545-4
Abrasion resistance				
a) Resistance to deep abrasion of unglazed tiles: removed volume, in cubic millimetres	Maximum 175			ISO 10545-6
b) Resistance to surface abrasion of glazed tiles intended for use on floors ^d	Report abrasion class and cycles passed			ISO 10545-7
Coefficient of linear thermal expansion ^e				
From ambient temperature to 100 °C	Test method available			ISO 10545-8
Thermal shock resistance ^e	Test method available			ISO 10545-9

Table H.1 (continued)

Physical property	Requirements	Test
Crazing resistance: glazed tiles ^f	Required	ISO 10545-11
Frost resistance	Required	ISO 10545-12
Moisture expansion, in millimetres per metre ^e	Test method available	ISO 10545-10
Small colour differences ^e	Plain coloured tiles only where required GL: $\Delta E < 0,75$ UGL: $\Delta E < 1,0$	ISO 10545-16
Impact resistance ^e	Test method available	ISO 10545-5
Chemical property	Requirements	Test
Resistance to staining		
a) Glazed tiles	Minimum class 3	ISO 10545-14
b) Unglazed tiles ^e	Test method available	ISO 10545-14
Resistance to chemicals		
Resistance to low concentrations of acids and alkalis:		
a) glazed tiles;	Manufacturer is to state classification	ISO 10545-13
b) unglazed tiles.	Manufacturer is to state classification	ISO 10545-13
Resistance to high concentrations of acids and alkalis ^e	Test method available	ISO 10545-13
Resistance to household chemicals and swimming pool salts:		
a) glazed tiles;	Minimum GB	ISO 10545-13
b) unglazed tiles.	Minimum UB	
Lead and cadmium release ^e	Test method available	ISO 10545-15
<p>^a Similar joint widths are to be used to apply to traditional systems based on non-metric sizes.</p> <p>^b Not applicable to tiles having curved shapes.</p> <p>^c As a result of firing, slight variations from this standard colour are unavoidable. This does not apply to intentional irregularities of colour variation of the face of tiles (which can be unglazed, glazed or partly glazed) or to the colour variation over a tile area which is characteristic for this type of tile and desirable. Spots or coloured dots which are introduced for decorative purposes are not considered a defect.</p> <p>^d Use Annex N for the abrasion resistance classification for all glazed tiles intended for use on floors.</p> <p>^e Annex P gives information regarding requirements which are non-compulsory but which are listed as "test method available".</p> <p>^f Certain decorative effects can have a tendency to craze. These are to be identified by the manufacturer, in which case the crazing test given in ISO 10545-11 is not applicable.</p> <p>^g Where applicable, tile thickness shall include the addition of back feet heights, as measured in accordance with Figure 3.</p>		

Annex I (informative)

On the request of ISO/TC 189, this annex is intentionally left blank. This is as a convenience to producers in order to avoid changes to packaging and related costs. In addition, at the time of publication, the market offers consumers various products identified by the matching annex numbers of this International Standard.

Annex J (normative)

Dry-pressed ceramic tiles $3 \% < E_b \leq 6 \%$ Group BII_a

J.1 Requirements

Dimensional and surface quality requirements and physical and chemical properties are required to be in accordance with Table I.1.

Table J.1 — Requirements for dry-pressed ceramic tiles — Group BII_a, $3 \% < E_b \leq 6 \%$

Dimensions and surface quality	Nominal size N			Test
	7 cm ≤ N < 15 cm	N ≥ 15 cm		
	mm	%	mm	
Length and width				
The manufacturer shall choose the work size as follows: a) for modular tiles in order to allow a nominal joint width of between 2 mm and 5 mm ^a ; b) for non-modular tiles so that the difference between the work size and the nominal size is not more than ± 2 % (max. ± 5 mm).				
The deviation, in per cent, of the average size for each tile (two or four sides) from the work size, S_w	± 0,9	± 0,6	± 2,0	ISO 10545-2
Thickness				
a) The thickness shall be specified by the manufacturer ^g				
b) The deviation, in per cent, of the average thickness of each tile from the work size thickness ^g	± 0,5	± 5	± 0,5	ISO 10545-2
Straightness of sides^b (facial sides)				
The maximum deviation from straightness, in per cent, related to the corresponding work sizes	± 0,75	± 0,5	± 1,5	ISO 10545-2
Rectangularity^b				
The maximum deviation from rectangularity, in per cent, related to the corresponding work sizes	± 0,75	± 0,5	± 2,0	ISO 10545-2

Table J.1 (continued)

Dimensions and surface quality	Nominal size N			Test
	7 cm ≤ N < 15 cm	N ≥ 15 cm		
	mm	%	mm	
Surface flatness				
The maximum deviation from flatness, in per cent:				
a) centre curvature, related to diagonal calculated from the work sizes;	± 0,75	± 0,5	± 2,0	ISO 10545-2
b) edge curvature, related to the corresponding work sizes;	± 0,75	± 0,5	± 2,0	ISO 10545-2
c) warpage, related to diagonal calculated from the work sizes.	± 0,75	± 0,5	± 2,0	ISO 10545-2
Back feet (if specified)				
a) Height, <i>h</i> , for tiles of surface area, <i>A</i>				
49 cm ² ≤ <i>A</i> < 60 cm ²	Minimum <i>h</i> = 0,7 mm; Maximum <i>h</i> = 3,5 mm			Figure 3
<i>A</i> ≥ 60 cm ²	Minimum <i>h</i> = 1,5 mm; Maximum <i>h</i> = 3,5 mm			Figure 3
b) Shape	Back feet as specified by the manufacturer and as shown in one of the examples in Figure 3			Figure 3
Example 1 (see Figure 3)	$L_0 - L_1 > 0$			Figure 3
Example 2 (see Figure 3)	$L_0 - L_2 > 0$			Figure 3
Example 3 (see Figure 3)	$L_0 - L_3 > 0$			Figure 3
Surface quality^c	A minimum of 95 % of the tiles are to be free from visible defects which can impair the appearance of a major area of tiles			ISO 10545-2
Physical property	Requirements			Test
Water absorption Per cent mass fraction	3 % < E_b ≤ 6 % Individual maximum 6,5 %			ISO 10545-3
Breaking strength, in Newtons				
a) Thickness ≥ 7,5 mm	Not less than 1 000			ISO 10545-4
b) Thickness < 7,5 mm	Not less than 600			ISO 10545-4
Modulus of rupture, in Newtons per square millimetre Not applicable to tiles with breaking strength ≥ 3 000 N	Minimum 22 Individual minimum 20			ISO 10545-4
Abrasion resistance				
a) Resistance to deep abrasion of unglazed tiles: removed volume, in cubic millimetres	Maximum 345			ISO 10545-6
b) Resistance to surface abrasion of glazed tiles intended for use on floors ^d	Report abrasion class and cycles passed			ISO 10545-7
Coefficient of linear thermal expansion^e				
From ambient temperature to 100 °C	Test method available			ISO 10545-8
Thermal shock resistance^e	Test method available			ISO 10545-9

Table J.1 (continued)

Physical property	Requirements	Test
Crazing resistance: glazed tiles ^f	Required	ISO 10545-11
Frost resistance ^e	Test method available	ISO 10545-12
Moisture expansion, in millimetres per metre ^e	Test method available	ISO 10545-10
Small colour differences ^e	Plain coloured tiles only where required GL: $\Delta E < 0,75$ UGL: $\Delta E < 1,0$	ISO 10545-16
Impact resistance ^e	Test method available	ISO 10545-5
Chemical property	Requirements	Test
Resistance to staining		
a) Glazed tiles	Minimum class 3	ISO 10545-14
b) Unglazed tiles ^e	Test method available	ISO 10545-14
Resistance to chemicals		
Resistance to low concentrations of acids and alkalis:		
a) glazed tiles;	Manufacturer is to state classification	ISO 10545-13
b) unglazed tiles.	Manufacturer is to state classification	ISO 10545-13
Resistance to high concentrations of acids and alkalis ^e	Test method available	ISO 10545-13
Resistance to household chemicals and swimming pool salts:		
a) glazed tiles;	Minimum GB	ISO 10545-13
b) unglazed tiles.	Minimum UB	
Lead and cadmium release ^e	Test method available	ISO 10545-15
<p>a Similar joint widths are to be used to apply to traditional systems based on non-metric sizes.</p> <p>b Not applicable to tiles having curved shapes.</p> <p>c As a result of firing, slight variations from this standard colour are unavoidable. This does not apply to intentional irregularities of colour variation of the face of tiles (which can be unglazed, glazed or partly glazed) or to the colour variation over a tile area which is characteristic for this type of tile and desirable. Spots or coloured dots which are introduced for decorative purposes are not considered a defect.</p> <p>d Use Annex N for the abrasion resistance classification for all glazed tiles intended for use on floors.</p> <p>e Annex P gives information regarding requirements which are non-compulsory but which are listed as "test method available".</p> <p>f Certain decorative effects can have a tendency to craze. These are to be identified by the manufacturer, in which case the crazing test given in ISO 10545-11 is not applicable.</p> <p>g Where applicable, tile thickness shall include the addition of back feet heights, as measured in accordance with Figure 3.</p>		

Annex K (normative)

Dry-pressed ceramic tiles $6\% < E_b \leq 10\%$ Group BII_b

K.1 Requirements

Dimensional and surface quality requirements and physical and chemical properties are required to be in accordance with Table J.1.

Table K.1 — Requirements for dry-pressed ceramic tiles — Group BII_b, $6\% < E_b \leq 10\%$

Dimensions and surface quality	Nominal size N			Test
	7 cm ≤ N < 15 cm	N ≥ 15 cm		
	mm	%	mm	
Length and width				
The manufacturer shall choose the work size as follows: a) for modular tiles in order to allow a nominal joint width of between 2 mm and 5 mm ^a ; b) for non-modular tiles so that the difference between the work size and the nominal size is not more than ± 2 % (max. ± 5 mm).				
The deviation, in per cent, of the average size for each tile (two or four sides) from the work size, S_w	± 0,9	± 0,6	± 2,0	ISO 10545-2
Thickness				
a) The thickness shall be specified by the manufacturer ^g				
b) The deviation, in per cent, of the average thickness of each tile from the work size thickness ^g	± 0,5	± 5	± 0,5	ISO 10545-2
Straightness of sides^b (facial sides)				
The maximum deviation from straightness, in per cent, related to the corresponding work sizes	± 0,75	± 0,5	± 1,5	ISO 10545-2
Rectangularity^b				
The maximum deviation from rectangularity, in per cent, related to the corresponding work sizes	± 0,75	± 0,5	± 2,0	ISO 10545-2

Table K.1 (continued)

Dimensions and surface quality	Nominal size N			Test
	7 cm ≤ N < 15 cm	N ≥ 15 cm		
	mm	%	mm	
Surface flatness				
The maximum deviation from flatness, in per cent:				
a) centre curvature, related to diagonal calculated from the work sizes;	± 0,75	± 0,5	± 2,0	ISO 10545-2
b) edge curvature, related to the corresponding work sizes;	± 0,75	± 0,5	± 2,0	ISO 10545-2
c) warpage, related to diagonal calculated from the work sizes.	± 0,75	± 0,5	± 2,0	ISO 10545-2
Back feet (if specified)				
a) Height, <i>h</i> , for tiles of surface area, <i>A</i>				
49 cm ² ≤ <i>A</i> < 60 cm ²	Minimum <i>h</i> = 0,7 mm; Maximum <i>h</i> = 3,5 mm			Figure 3
<i>A</i> ≥ 60 cm ²	Minimum <i>h</i> = 1,5 mm; Maximum <i>h</i> = 3,5 mm			Figure 3
b) Shape	Back feet as specified by the manufacturer and as shown in one of the examples in Figure 3			Figure 3
Example 1 (see Figure 3)	$L_0 - L_1 > 0$			Figure 3
Example 2 (see Figure 3)	$L_0 - L_2 > 0$			Figure 3
Example 3 (see Figure 3)	$L_0 - L_3 > 0$			Figure 3
Surface quality ^c	A minimum of 95 % of the tiles are to be free from visible defects which can impair the appearance of a major area of tiles			ISO 10545-2
Physical property	Requirements			Test
Water absorption Per cent mass fraction	6 % < E_b ≤ 10 % Individual maximum 11 %			ISO 10545-3
Breaking strength, in Newtons				
a) Thickness ≥ 7,5 mm	Not less than 800			ISO 10545-4
b) Thickness < 7,5 mm	Not less than 500			ISO 10545-4
Modulus of rupture, in Newtons per square millimetre Not applicable to tiles with breaking strength ≥ 3 000 N	Minimum 18 Individual minimum 16			ISO 10545-4
Abrasion resistance				
a) Resistance to deep abrasion of unglazed tiles: removed volume, in cubic millimetres	Maximum 540			ISO 10545-6
b) Resistance to surface abrasion of glazed tiles intended for use on floors ^d	Report abrasion class and cycles passed			ISO 10545-7
Coefficient of linear thermal expansion ^e				
From ambient temperature to 100 °C	Test method available			ISO 10545-8
Thermal shock resistance ^e	Test method available			ISO 10545-9

Table K.1 (continued)

Physical property	Requirements	Test
Crazing resistance: glazed tiles ^f	Required	ISO 10545-11
Frost resistance ^e	Test method available	ISO 10545-12
Moisture expansion, in millimetres per metre ^e	Test method available	ISO 10545-10
Small colour differences ^e	Plain coloured tiles only where required GL: $\Delta E < 0,75$ UGL: $\Delta E < 1,0$	ISO 10545-16
Impact resistance ^e	Test method available	ISO 10545-5
Chemical property	Requirements	Test
Resistance to staining		
a) Glazed tiles	Minimum class 3	ISO 10545-14
b) Unglazed tiles ^e	Test method available	ISO 10545-14
Resistance to chemicals		
Resistance to low concentrations of acids and alkalis:		
a) glazed tiles;	Manufacturer is to state classification	ISO 10545-13
b) unglazed tiles.	Manufacturer is to state classification	ISO 10545-13
Resistance to high concentrations of acids and alkalis ^e	Test method available	ISO 10545-13
Resistance to household chemicals and swimming pool salts:		
a) glazed tiles;	Minimum GB	ISO 10545-13
b) unglazed tiles.	Minimum UB	
Lead and cadmium release ^e	Test method available	ISO 10545-15
<p>^a Similar joint widths are to be used to apply to traditional systems based on non-metric sizes.</p> <p>^b Not applicable to tiles having curved shapes.</p> <p>^c As a result of firing, slight variations from this standard colour are unavoidable. This does not apply to intentional irregularities of colour variation of the face of tiles (which can be unglazed, glazed or partly glazed) or to the colour variation over a tile area which is characteristic for this type of tile and desirable. Spots or coloured dots which are introduced for decorative purposes are not considered a defect.</p> <p>^d Use Annex N for the abrasion resistance classification for all glazed tiles intended for use on floors.</p> <p>^e Annex P gives information regarding requirements which are non-compulsory but which are listed as "test method available".</p> <p>^f Certain decorative effects can have a tendency to craze. These are to be identified by the manufacturer, in which case the crazing test given in ISO 10545-11 is not applicable.</p> <p>^g Where applicable, tile thickness shall include the addition of back feet heights, as measured in accordance with Figure 3.</p>		

Annex L (normative)

Dry-pressed ceramic tiles $E_b > 10\%$ Group BIII

L.1 Requirements

Dimensional and surface quality requirements and physical and chemical properties are required to be in accordance with Table K.1.

Table L.1 — Requirements for dry-pressed ceramic tiles — Group BIII, $E_b > 10\%$

Dimensions and surface quality	Nominal size N			Test
	7 cm ≤ N < 15 cm	N ≥ 15 cm		
	mm	%	mm	
Length and width				
The manufacturer shall choose the work size as follows: a) for modular tiles in order to allow a nominal joint width of between 1,5 mm and 5 mm ^a ; b) for non-modular tiles so that the difference between the work size and the nominal size is not more than ± 2 % (max. ± 5 mm).				
The deviation, in per cent, of the average size for each tile (two or four sides) from the work size, S_w	± 0,75	± 0,5	± 2,0	ISO 10545-2
Thickness				
a) The thickness shall be specified by the manufacturer ^h				
b) The deviation, in per cent, of the average thickness of each tile from the work size thickness ^h	± 0,5	± 10	± 0,5	ISO 10545-2
Straightness of sides^b (facial sides)				
The maximum deviation from straightness, in per cent, related to the corresponding work sizes	± 0,5	± 0,3	± 1,5	ISO 10545-2
Rectangularity^b				
The maximum deviation from rectangularity, in per cent, related to the corresponding work sizes	± 0,75	± 0,5	± 2,0	ISO 10545-2

Table L.1 (continued)

Dimensions and surface quality	Nominal size N			Test
	7 cm ≤ N < 15 cm	N ≥ 15 cm		
	mm	%	mm	
Surface flatness				
The maximum deviation from flatness, in per cent:				
a) centre curvature, related to diagonal calculated from the work sizes;	+0,75 -0,5	+0,5 -0,3	+2,0 -1,5	ISO 10545-2
b) edge curvature, related to the corresponding work sizes;	+0,75 -0,5	+0,5 -0,3	+2,0 -1,5	ISO 10545-2
c) warpage, related to diagonal calculated from the work sizes.	± 0,75	± 0,5	± 2,0	ISO 10545-2
Back feet (if specified)				
a) Height, <i>h</i> , for tiles of surface area, <i>A</i>				
49 cm ² ≤ <i>A</i> < 60 cm ²	Minimum <i>h</i> = 0,7 mm; Maximum <i>h</i> = 3,5 mm			Figure 3
<i>A</i> ≥ 60 cm ²	Minimum <i>h</i> = 1,5 mm; Maximum <i>h</i> = 3,5 mm			Figure 3
b) Shape	Back feet as specified by the manufacturer and as shown in one of the examples in Figure 3			Figure 3
Example 1 (see Figure 3)	$L_0 - L_1 > 0$			Figure 3
Example 2 (see Figure 3)	$L_0 - L_2 > 0$			Figure 3
Example 3 (see Figure 3)	$L_0 - L_3 > 0$			Figure 3
Surface quality ^c	A minimum of 95 % of the tiles are to be free from visible defects which can impair the appearance of a major area of tiles			ISO 10545-2
Physical property	Requirements			Test
Water absorption Per cent mass fraction	$E_b > 10$ %. Where the average exceeds 20 %, this shall be indicated by the manufacturer Individual minimum value 9 %			ISO 10545-3
Breaking strength, in Newtons ^g				
a) Thickness ≥ 7,5 mm	Not less than 600			ISO 10545-4
b) Thickness < 7,5 mm	Not less than 200			ISO 10545-4
Modulus of rupture, in Newtons per square millimetre Not applicable to tiles with breaking strength ≥ 3 000 N				ISO 10545-4
a) Thickness ≥ 7,5 mm	Minimum 12			ISO 10545-4
b) Thickness < 7,5 mm	Minimum 15			ISO 10545-4
Abrasion resistance				
Resistance to surface abrasion of glazed tiles intended for use on floors ^d	Report abrasion class and cycles passed			ISO 10545-7
Coefficient of linear thermal expansion ^e				
From ambient temperature to 100 °C	Test method available			ISO 10545-8

Table L.1 (continued)

Physical property	Requirements	Test
Thermal shock resistance ^e	Test method available	ISO 10545-9
Crazing resistance: glazed tiles ^f	Required	ISO 10545-11
Frost resistance ^e	Test method available	ISO 10545-12
Moisture expansion, in millimetres per metre ^e	Test method available	ISO 10545-10
Small colour differences ^e	Plain coloured tiles only where required GL: $\Delta E < 0,75$ UGL: $\Delta E < 1,0$	ISO 10545-16
Impact resistance ^e	Test method available	ISO 10545-5
Chemical property	Requirements	Test
Resistance to staining		
a) Glazed tiles	Minimum class 3	ISO 10545-14
Resistance to chemicals		
Resistance to low concentrations of acids and alkalis	Test method available	ISO 10545-13
Resistance to high concentrations of acids and alkalis ^e	Test method available	ISO 10545-13
Resistance to household chemicals and swimming pool salts: glazed tiles	Minimum GB	ISO 10545-13
Lead and cadmium release^e	Test method available	ISO 10545-15
<p>a Similar joint widths are to be used to apply to traditional systems based on non-metric sizes.</p> <p>b Not applicable to tiles having curved shapes.</p> <p>c As a result of firing, slight variations from this standard colour are unavoidable. This does not apply to intentional irregularities of colour variation of the face of tiles (which can be unglazed, glazed or partly glazed) or to the colour variation over a tile area which is characteristic for this type of tile and desirable. Spots or coloured dots which are introduced for decorative purposes are not considered a defect.</p> <p>d Use Annex N for the abrasion resistance classification for all glazed tiles intended for use on floors.</p> <p>e Annex P gives information regarding requirements which are non-compulsory but which are listed as "test method available".</p> <p>f Certain decorative effects can have a tendency to craze. These are to be identified by the manufacturer, in which case the crazing test given in ISO 10545-11 is not applicable.</p> <p>g Tiles with breaking strength less than 400 N are intended for use on walls only and the manufacturer is required to specify the intended use.</p> <p>h Where applicable, tile thickness shall include the addition of back feet heights, as measured in accordance with Figure 3.</p>		

Annex M (normative)

Extruded ceramic tiles with low water absorption

$$E_b \leq 0,5 \%$$

Group AI_a

M.1 Requirements

Dimensional and surface quality requirements and physical and chemical properties are required to be in accordance with Table L.1.

Table M.1 — Requirements for extruded ceramic tiles — Group AI_a, $E_b < 0,5 \%$

Dimensions and surface quality	Precision	Natural	Test
Length and width			
The manufacturer shall choose the work size as follows: a) for modular tiles in order to allow a nominal joint width of between 3 mm and 11 mm ^a ; b) for non-modular tiles so that the difference between the work size and the nominal size is not more than ± 3 mm.			
The deviation, in per cent, of the average size for each tile (two or four sides) from the work size, S_w	$\pm 1,0 \%$ to a maximum of ± 2 mm	$\pm 2,0 \%$ to a maximum of ± 4 mm	ISO 10545-2
The deviation, in per cent, of the average size for each tile (two or four sides) from the average size of the 10 test specimens (20 or 40 sides)	$\pm 1,0 \%$	$\pm 1,5 \%$	ISO 10545-2
Thickness			
a) The thickness shall be specified by the manufacturer ^h			
b) The deviation, in per cent, of the average thickness of each tile from the work size thickness ^h	$\pm 10 \%$	$\pm 10 \%$	ISO 10545-2
Straightness of sides^b (facial sides)			
The maximum deviation from straightness, in per cent, related to the corresponding work sizes	$\pm 0,5 \%$	$\pm 0,6 \%$	ISO 10545-2
Rectangularity^b			
The maximum deviation from rectangularity, in per cent, related to the corresponding work sizes	$\pm 1,0 \%$	$\pm 1,0 \%$	ISO 10545-2

Table M.1 (continued)

Dimensions and surface quality	Precision	Natural	Test
Surface flatness			
The maximum deviation from flatness, in per cent:			
a) centre curvature, related to diagonal calculated from the work sizes;	$\pm 0,5 \%$	$\pm 1,5 \%$	ISO 10545-2
b) edge curvature, related to the corresponding work sizes;	$\pm 0,5 \%$	$\pm 1,5 \%$	ISO 10545-2
c) warpage, related to diagonal calculated from the work sizes.	$\pm 0,8 \%$	$\pm 1,5 \%$	ISO 10545-2
Back feet (if specified)			
a) Height, h , for tiles of surface area, A			
$49 \text{ cm}^2 \leq A < 60 \text{ cm}^2$	Minimum $h = 0,7 \text{ mm}$; Maximum $h = 3,5 \text{ mm}$		Figure 3
$A \geq 60 \text{ cm}^2$	Minimum $h = 1,5 \text{ mm}$; Maximum $h = 3,5 \text{ mm}$		Figure 3
b) Shape	Back feet as specified by the manufacturer and as shown in one of the examples in Figure 3		Figure 3
Example 1 (see Figure 3)	$L_0 - L_1 > 0$		Figure 3
Example 2 (see Figure 3)	$L_0 - L_2 > 0$		Figure 3
Example 3 (see Figure 3)	$L_0 - L_3 > 0$		Figure 3
Surface quality ^c	A minimum of 95 % of the tiles are to be free from visible defects which can impair the appearance of a major area of tiles		ISO 10545-2
Physical property	Precision	Natural	Test
Water absorption Per cent mass fraction ^g	$E_b \leq 0,5 \%$ Individual maximum 0,6 %	$E_b \leq 0,5 \%$ Individual maximum 0,6 %	ISO 10545-3
Breaking strength, in Newtons			
a) Thickness $\geq 7,5 \text{ mm}$	Not less than 1 300	Not less than 1 300	ISO 10545-4
b) Thickness $< 7,5 \text{ mm}$	Not less than 600	Not less than 600	ISO 10545-4
Modulus of rupture, in Newtons per square millimetre Not applicable to tiles with breaking strength $\geq 3\,000 \text{ N}$	Minimum 28 Individual minimum 21	Minimum 28 Individual minimum 21	ISO 10545-4
Abrasion resistance			
a) Resistance to deep abrasion of unglazed tiles: removed volume, in cubic millimetres	Maximum 275	Maximum 275	ISO 10545-6
b) Resistance to surface abrasion of glazed tiles intended for use on floors ^d	Report abrasion class and cycles passed	Report abrasion class and cycles passed	ISO 10545-7
Coefficient of linear thermal expansion ^e			
From ambient temperature to $100 \text{ }^\circ\text{C}$	Test method available	Test method available	ISO 10545-8
Thermal shock resistance ^e	Test method available	Test method available	ISO 10545-9

Table M.1 (continued)

Physical property	Precision	Natural	Test
Crazing resistance: glazed tiles ^f	Required	Required	ISO 10545-11
Frost resistance	Required	Required	ISO 10545-12
Moisture expansion, in millimetres per metre ^e	Test method available	Test method available	ISO 10545-10
Small colour differences ^e	Plain coloured tiles only where required GL: $\Delta E < 0,75$ UGL: $\Delta E < 1,0$	Plain coloured tiles only where required GL: $\Delta E < 0,75$ UGL: $\Delta E < 1,0$	ISO 10545-16
Impact resistance ^e	Test method available	Test method available	ISO 10545-5
Chemical property	Precision	Natural	Test
Resistance to staining			
a) Glazed tiles	Minimum class 3	Minimum class 3	ISO 10545-14
b) Unglazed tiles ^e	Test method available	Test method available	ISO 10545-14
Resistance to chemicals			
Resistance to low concentrations of acids and alkalis:			
a) glazed tiles; b) unglazed tiles.	Manufacturer is to state classification	Manufacturer is to state classification	ISO 10545-13
Resistance to high concentrations of acids and alkalis ^e	Test method available	Test method available	ISO 10545-13
Resistance to household chemicals and swimming pool salts:			
a) glazed tiles; b) unglazed tiles.	Minimum GB Minimum UB	Minimum GB Minimum UB	ISO 10545-13
Lead and cadmium release ^e	Test method available	Test method available	ISO 10545-15
<p>^a Similar joint widths are to be used to apply to traditional systems based on non-metric sizes.</p> <p>^b Not applicable to tiles having curved shapes.</p> <p>^c As a result of firing, slight variations from this standard colour are unavoidable. This does not apply to intentional irregularities of colour variation of the face of tiles (which can be unglazed, glazed or partly glazed) or to the colour variation over a tile area which is characteristic for this type of tile and desirable. Spots or coloured dots which are introduced for decorative purposes are not considered a defect.</p> <p>^d Use Annex N for the abrasion resistance classification for all glazed tiles intended for use on floors.</p> <p>^e Annex P gives information regarding requirements which are non-compulsory but which are listed as "test method available".</p> <p>^f Certain decorative effects can have a tendency to craze. These are to be identified by the manufacturer, in which case the crazing test given in ISO 10545-11 is not applicable.</p> <p>^g A fully vitrified tile is a tile with water absorption of a maximum individual value of 0,5 % (porcelain tile).</p> <p>^h Where applicable, tile thickness shall include the addition of back feet heights, as measured in accordance with Figure 3.</p>			

Annex N (informative)

Classification of glazed tiles for floors according to their abrasion resistance

This approximate classification is given for guidance only (see ISO 10545-7). It is not to be taken to provide accurate product specifications for specific requirements.

- Class 0 Glazed tiles in this class are not recommended for use on floors.
- Class 1 Floor coverings in areas which are walked on, essentially with soft-soled footwear or bare feet without scratching dirt (for example residential bathrooms and bedrooms without direct access from the outside).
- Class 2 Floor coverings in areas which are walked on by soft-soled or normal footwear, with, at the most, occasional small amounts of scratching dirt (for example rooms in the living areas of homes, but with the exception of kitchens, entrances and other rooms which can have a lot of traffic). This does not apply to abnormal footwear, for example hobnailed boots.
- Class 3 Floor coverings in areas which, with normal footwear, are walked on more often with small amounts of scratching dirt (for example residential kitchens, halls, corridors, balconies, loggias and terraces). This does not apply to abnormal footwear, for example hobnailed boots.
- Class 4 Floor coverings which are walked on by regular traffic with some scratching dirt so that the conditions are more severe than class 3 (for example entrances, commercial kitchens, hotel, exhibition and sale rooms).
- Class 5 Floor coverings which are subjected to severe pedestrian traffic over sustained periods with some scratching dirt, so that the conditions are the most severe for which glazed floor tiles are to be suitable (for example public areas, such as shopping centres, airport concourses, hotel foyers, public walkways and industrial applications).

This classification is valid for the given applications under normal conditions. Consideration should be given to the footwear, type of traffic and cleaning methods expected, and the floors should be adequately protected against scratching dirt at the entrances to buildings by interposing footwear cleaning devices. In extreme cases of very heavy traffic and quantities of scratching dirt, unglazed floor tiles and quarries from Group I may be considered.

Annex O (informative)

On the request of ISO/TC 189, this annex is intentionally left blank. This is as a convenience to producers in order to avoid changes to packaging and related costs. In addition, at the time of publication, the market offers consumers various products identified by the matching annex numbers of this International Standard.

Annex P (informative)

Test methods

A number of test methods that are included in this International Standard are available on request, but do not form part of the compulsory test requirements. The purpose of this annex is to provide explanatory comments on the inclusion of these tests and other pertinent information.

- ISO 10545-5: this test is intended only for testing tiles which are used in areas where impact resistance is considered to be of particular importance. The normal requirement for light-duty installations is a coefficient of restitution of 0,55. For heavier duty applications, a higher figure is required.
- ISO 10545-8: most ceramic tiles have low levels of linear thermal expansion. This test is intended for tiles which are installed in conditions of high thermal variation.
- ISO 10545-9: all ceramic tiles withstand high temperatures. This test is to be applied to any ceramic tile which is subjected to localized thermal shock.
- ISO 10545-10: the majority of glazed and unglazed tiles have negligible moisture expansion, which does not contribute to tiling problems if tiles are correctly fixed (installed). However, with unsatisfactory fixing practices or in certain climatic conditions, moisture expansion in excess of 0,06 % (0,6 mm/m) can contribute to problems.
- ISO 10545-12: this test is compulsory only for products which are intended to be specified for use where frost can apply. The test is not required for product groups which are generally unsuitable for use where frost is present.
- ISO 10545-13: ceramic tiles are normally resistant to common chemicals. The test for high concentrations of acids and alkalis is intended for ceramic tiles which are to be used in potentially corrosive conditions.
- ISO 10545-14: this test is compulsory for glazed tiles. For unglazed tiles, where staining is a problem, it is recommended that the manufacturer be consulted. This method does not address the temporary colour changes which can occur in certain types of glazed tile due to the absorption of water in the body under the glaze.
- ISO 10545-15: this test is intended for glazed tiles which are used on worktops and on wall surfaces where food preparation takes place, and in cases where food is to be in direct contact with the glazed tile surface. For indicative limits, see Directive 2005/31/EC.
- ISO 10545-16: this test is only applicable to plain coloured glazed or unglazed tiles and is considered to be of importance in certain specialized circumstances. It is to be used only where small colour differences between plain coloured tiles are important in a specification.

Annex Q (informative)

On the request of ISO/TC 189, this annex is intentionally left blank. This is as a convenience to producers in order to avoid changes to packaging and related costs. In addition, at the time of publication, the market offers consumers various products identified by the matching annex numbers of this International Standard.

Annex R (informative)

Symbols recommended for use

The use of symbols on packaging and/or literature is not a requirement except where stated; however, the symbols shown in Figure O.1 are recommended to indicate intended use:

- a) tile suitable for use on floors;
- b) tile suitable for use on walls;
- c) the numerals, of which this is an example, indicate the classification of a glazed tile intended for use on floors according to its abrasion resistance (see Annex N);
- d) symbol to indicate a frost-resistant tile.

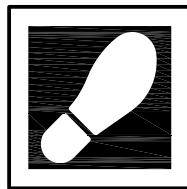

a)

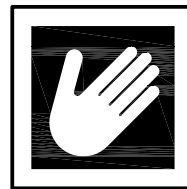

b)

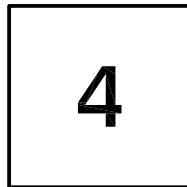

c)

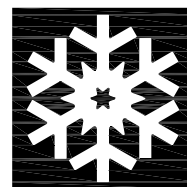

d)

Figure R.1 — Recommended symbols

Bibliography

- [1] European Commission, *European Commission Directive 2005/31/EC of 29 April 2005 amending Council Directive 84/500/EEC as regards a declaration of compliance and performance criteria of the analytical method for ceramic articles intended to come into contact with foodstuffs*

ICS 01.040.91; 91.100.23

Price based on 52 pages