

INTERNATIONAL  
STANDARD

ISO  
12992

Second edition  
2017-03

---

---

## Plastics — Vertical flame spread determination for film and sheet

*Plastiques — Détermination de la propagation verticale de la flamme  
sur films et feuilles*



Reference number  
ISO 12992:2017(E)

© ISO 2017



**COPYRIGHT PROTECTED DOCUMENT**

© ISO 2017, Published in Switzerland

All rights reserved. Unless otherwise specified, no part of this publication may be reproduced or utilized otherwise in any form or by any means, electronic or mechanical, including photocopying, or posting on the internet or an intranet, without prior written permission. Permission can be requested from either ISO at the address below or ISO's member body in the country of the requester.

ISO copyright office  
Ch. de Blandonnet 8 • CP 401  
CH-1214 Vernier, Geneva, Switzerland  
Tel. +41 22 749 01 11  
Fax +41 22 749 09 47  
copyright@iso.org  
www.iso.org

# Contents

	Page
<b>Foreword</b> .....	<b>iv</b>
<b>Introduction</b> .....	<b>v</b>
<b>1 Scope</b> .....	<b>1</b>
<b>2 Normative references</b> .....	<b>1</b>
<b>3 Terms and definitions</b> .....	<b>1</b>
<b>4 Significance of the test</b> .....	<b>2</b>
<b>5 Principle</b> .....	<b>3</b>
<b>6 Apparatus</b> .....	<b>3</b>
6.1 Laboratory fume hood .....	3
6.2 Conditioning room or chamber .....	3
6.3 Specimen holder .....	3
6.4 Marker rods .....	7
6.5 Gas burner .....	7
6.6 Fuel gas .....	7
6.7 Manometer and gas flow meter .....	7
6.8 Timing device .....	7
6.9 Measuring scale .....	7
6.10 Marker (permanent) .....	8
6.11 Micrometer .....	8
<b>7 Test specimens</b> .....	<b>8</b>
7.1 Extended application .....	8
7.2 Preparation of test specimens .....	8
<b>8 Procedure</b> .....	<b>9</b>
<b>9 Calculation and expression of results</b> .....	<b>11</b>
<b>10 Test report</b> .....	<b>11</b>
<b>Annex A (informative) Precision data</b> .....	<b>12</b>
<b>Bibliography</b> .....	<b>13</b>

## Foreword

ISO (the International Organization for Standardization) is a worldwide federation of national standards bodies (ISO member bodies). The work of preparing International Standards is normally carried out through ISO technical committees. Each member body interested in a subject for which a technical committee has been established has the right to be represented on that committee. International organizations, governmental and non-governmental, in liaison with ISO, also take part in the work. ISO collaborates closely with the International Electrotechnical Commission (IEC) on all matters of electrotechnical standardization.

The procedures used to develop this document and those intended for its further maintenance are described in the ISO/IEC Directives, Part 1. In particular the different approval criteria needed for the different types of ISO documents should be noted. This document was drafted in accordance with the editorial rules of the ISO/IEC Directives, Part 2 (see [www.iso.org/directives](http://www.iso.org/directives)).

Attention is drawn to the possibility that some of the elements of this document may be the subject of patent rights. ISO shall not be held responsible for identifying any or all such patent rights. Details of any patent rights identified during the development of the document will be in the Introduction and/or on the ISO list of patent declarations received (see [www.iso.org/patents](http://www.iso.org/patents)).

Any trade name used in this document is information given for the convenience of users and does not constitute an endorsement.

For an explanation on the meaning of ISO specific terms and expressions related to conformity assessment, as well as information about ISO's adherence to the World Trade Organization (WTO) principles in the Technical Barriers to Trade (TBT) see the following URL: [www.iso.org/iso/foreword.html](http://www.iso.org/iso/foreword.html)

This document was prepared by Technical Committee ISO/TC 61, *Plastics*, Subcommittee SC 4, *Burning behaviour*.

This second edition cancels and replaces the first edition (ISO 12992:1995), which has been technically revised.

The main changes compared to the previous edition are as follows:

- [Clause 2](#) has been updated;
- [Clause 3](#) has been updated;
- the precision data have been moved to [Annex A](#).

## Introduction

Thin flexible plastic films and sheets are widely used in products for packaging, building, housing, industries and transport media, in various applications. The burning behaviour, in particular, the vertical flame spread of flexible plastic films and sheet, is a concern for fire safety of these applications. This document gives a method of determination of vertical flame spread of flexible plastic films and sheets by small flame source.

This document is also intended as a pre-selection test for materials used for parts in devices and appliances. The final acceptance of the material would be dependent upon its use in complete equipment that conforms with the standards applicable to such equipment.

It should be noted that the test results obtained alone by the test specified in this document cannot give whole aspects of fire hazard of plastics films and sheets.



# Plastics — Vertical flame spread determination for film and sheet

## 1 Scope

This document specifies a test method for measurement of flame spread properties of vertically oriented specimens of plastics in the form of film and sheet, 3 mm or less thickness, subjected to a small igniting flame.

## 2 Normative references

The following documents are referred to in the text in such a way that some or all of their content constitutes requirements of this document. For dated references, only the edition cited applies. For undated references, the latest edition of the referenced document (including any amendments) applies.

ISO 11925-2, *Reaction to fire tests — Ignitability of products subjected to direct impingement of flame — Part 2: Single-flame source test*

ISO 13943, *Fire safety — Vocabulary*

## 3 Terms and definitions

For the purposes of this document, the terms and definitions given in ISO 13943 and the following apply.

ISO and IEC maintain terminological databases for use in standardization at the following addresses:

- IEC Electropedia: available at <http://www.electropedia.org/>
- ISO Online browsing platform: available at <http://www.iso.org/obp>

### 3.1

#### **afterglow**

persistence of glowing combustion after both removal of the ignition source and the cessation of any flaming combustion

[SOURCE: ISO 13943:2008, definition 4.8]

### 3.2

#### **flame-spread time**

time taken by a flame front on a burning material to travel a specified distance on the surface, or to cover a specified surface area under specified conditions

[SOURCE: ISO 13943:2008, definition 4.144]

### 3.3

#### **flaming droplet**

molten material separating from a burning item and continuing to flame during a fire or fire test

[SOURCE: ISO 13943:2008, definition 4.150]

### 3.4

#### **seat of flame**

flame location at the leading edge of the affected area

Note 1 to entry: See [Figure 1](#).

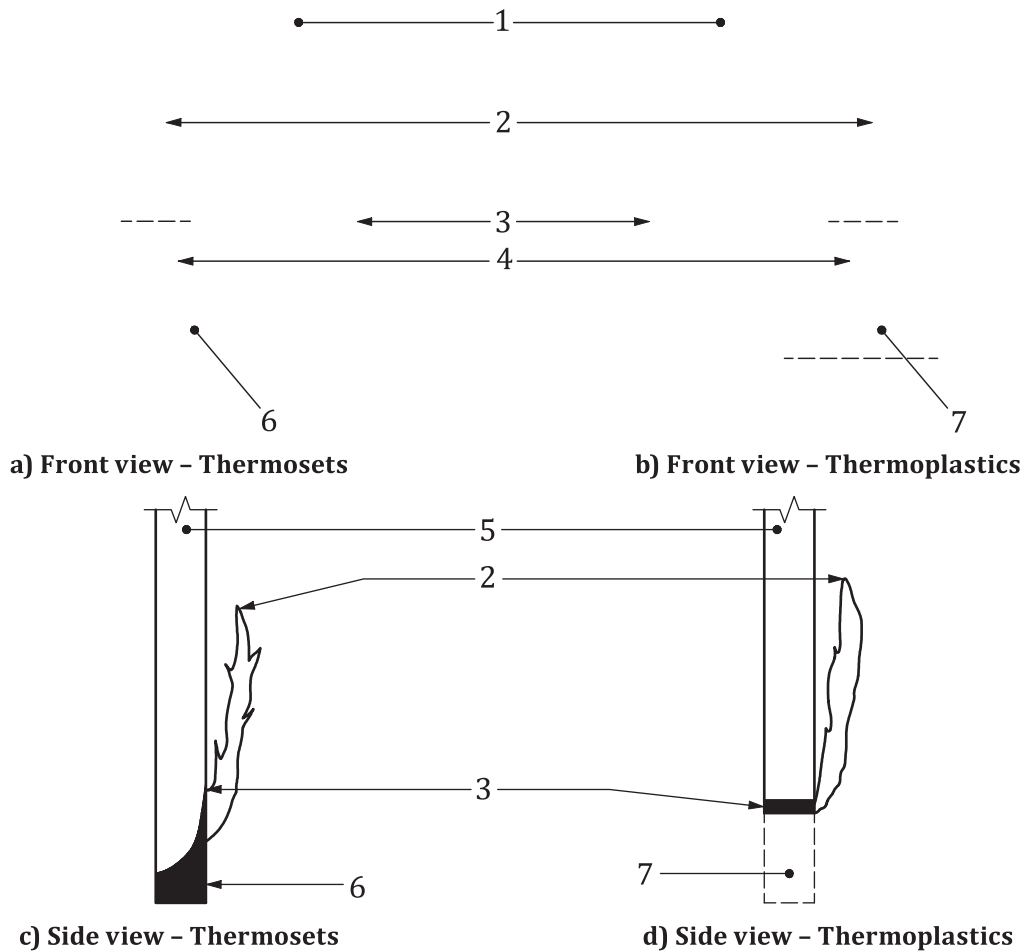

Figure 1 — Identification of seat of flame

#### 4 Significance of the test

4.1 Results obtained using the method described in this document can provide a sensitive measure of the burning characteristics of material under certain controlled laboratory conditions, and hence, may be useful for preselection or quality control purposes.

4.2 Results obtained from specimens of differing thickness, with different ignition sources and/or by different procedures are not comparable. Correlation with flammability behaviour under other fire conditions is not implied.

4.3 This test is not relevant for specimens which distort away from and out of reach of the test flame without ignition. Other test methods should be explored for such specimens.



**4.4** Results obtained by this document shall not be used alone to describe or appraise the fire hazard presented by a particular material type or shape under actual fire conditions. The results may be used as one element of a fire risk assessment, which takes into account all the factors which are pertinent to the assessment of the fire hazard of a particular end use for the material.

Precision data are given in [Annex A](#).

## 5 Principle

**5.1** A defined flame from a specified ignition source is applied to film or sheet specimens that are vertically oriented, for a specified period of time.

**5.2** The flame-spread time ([3.2](#)) is recorded and the flame spread rate between these two markings is calculated.

**5.3** Other properties relating to flame propagation, such as flaming droplets, extinguishing characteristics and afterglow, are observed and recorded.

## 6 Apparatus

### 6.1 Laboratory fume hood

The laboratory fume hood shall have an inside volume of at least 0,5 m<sup>3</sup>. The chamber shall permit observation of tests in progress and shall be draught free while allowing normal thermal circulation of air past the test specimen during burning. The inside surfaces of the chamber shall be of a dark colour. When a light meter, facing towards the rear of the chamber, is positioned in place of the test specimen, the recorded light level shall be less than 20 lx.

For safety and convenience, this enclosure (which can be completely closed) shall be fitted with an extraction device, such as an exhaust fan, to remove products of combustion that may be toxic. The extraction device shall be turned off during the test and turned on again immediately after the test to remove the fire effluents. A positive closing damper may be needed.

**NOTE** The amount of oxygen available to support combustion is naturally important for the conduct of these flame tests. For tests conducted by this method when burning times are protracted, chamber sizes greater than 0,5 m<sup>3</sup> can be needed to provide reproducible results.

### 6.2 Conditioning room or chamber

The conditioning room or chamber shall be capable of being maintained at  $(23 \pm 2)$  °C and  $(50 \pm 5)$  % relative humidity.

### 6.3 Specimen holder

As described in [Figure 2](#) to [Figure 4](#), the specimen holder shall be capable of supporting the specimen securely in a vertical position without excessively stressing it and providing support for marker rods across the front of the specimen.

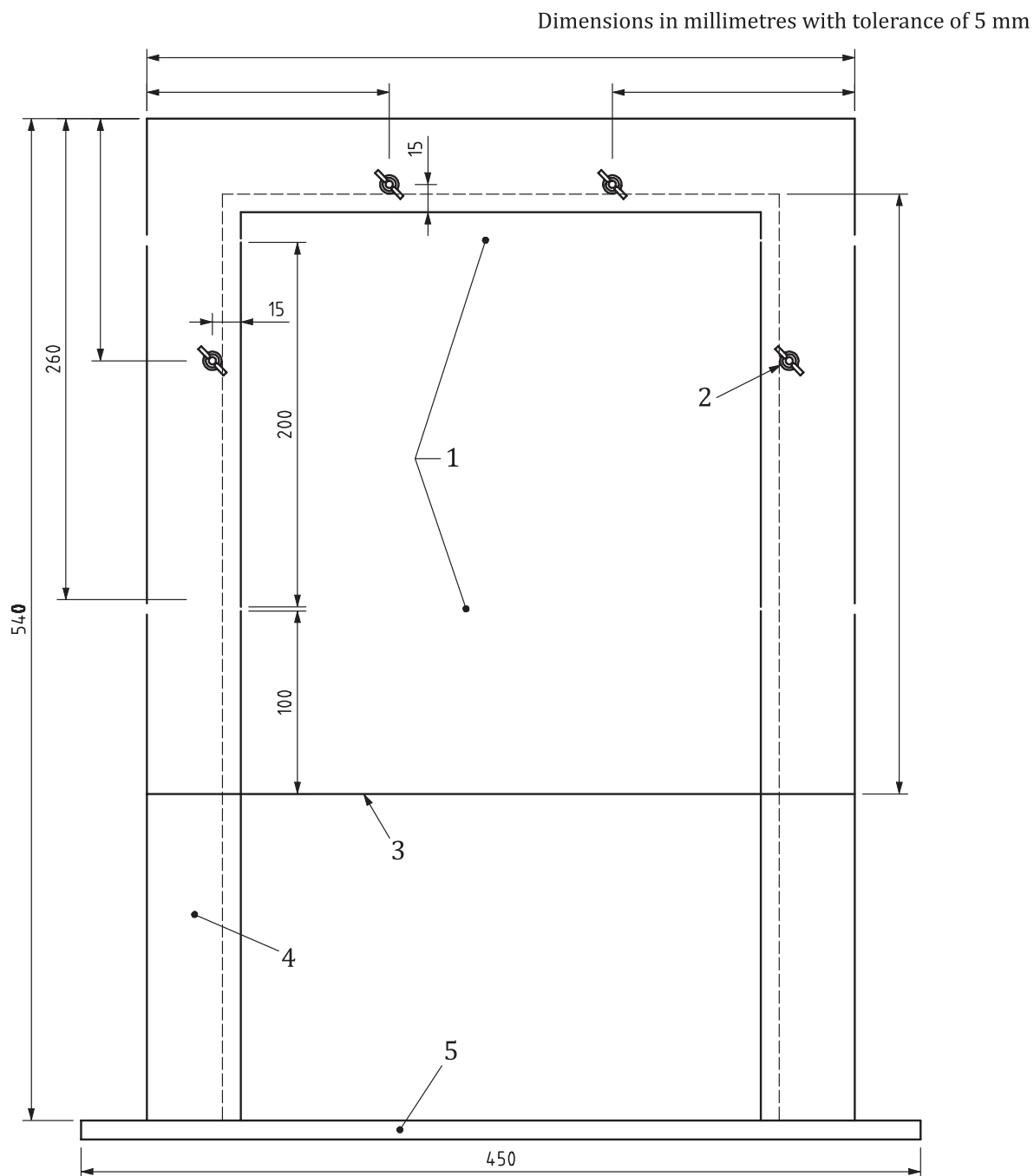

**Key**

- |   |  |   |  |
|---|--|---|--|
| 1 | marker rod in front of marker line         | 4 | extruded aluminium angle (50 × 50 × 3,5) |
| 2 | wing nut or cam-action clump               | 5 | aluminium plate (450 × 300 × 6)          |
| 3 | specimen located between protruding screws |   |  |

**Figure 2 — Specimen support fixture (Front view)**

Dimensions in millimetres with tolerance of 5 mm not otherwise specified

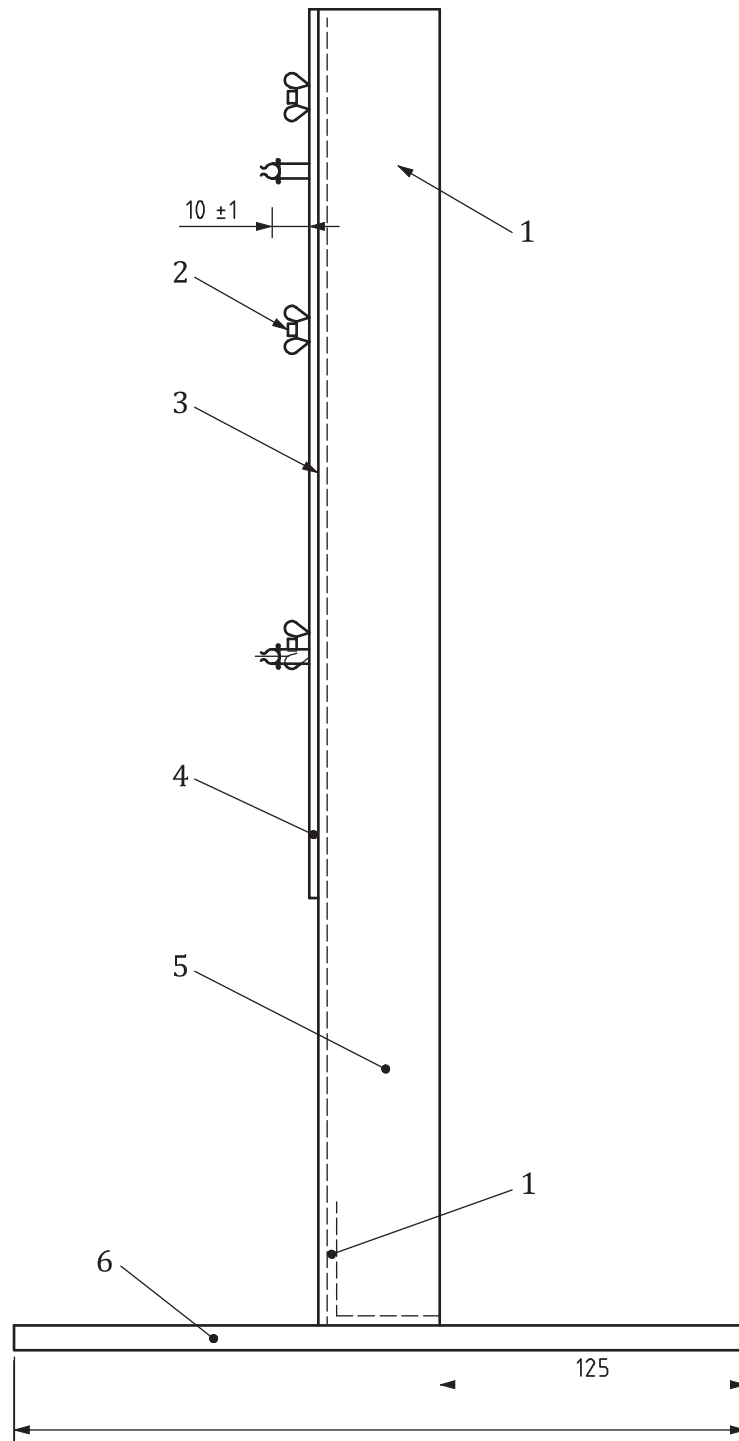

**Key**

- |   |  |   |                             |
|---|--|---|-----------------------------|
| 1 | angle bracket installed with bolts, screws or rivets | 4 | specimen hold-down plate    |
| 2 | wing nut or cam-action clump                         | 5 | support frame               |
| 3 | specimen   | 6 | 6 mm + 1 mm aluminium plate |

**Figure 3 — Specimen support fixtures (Side view)**

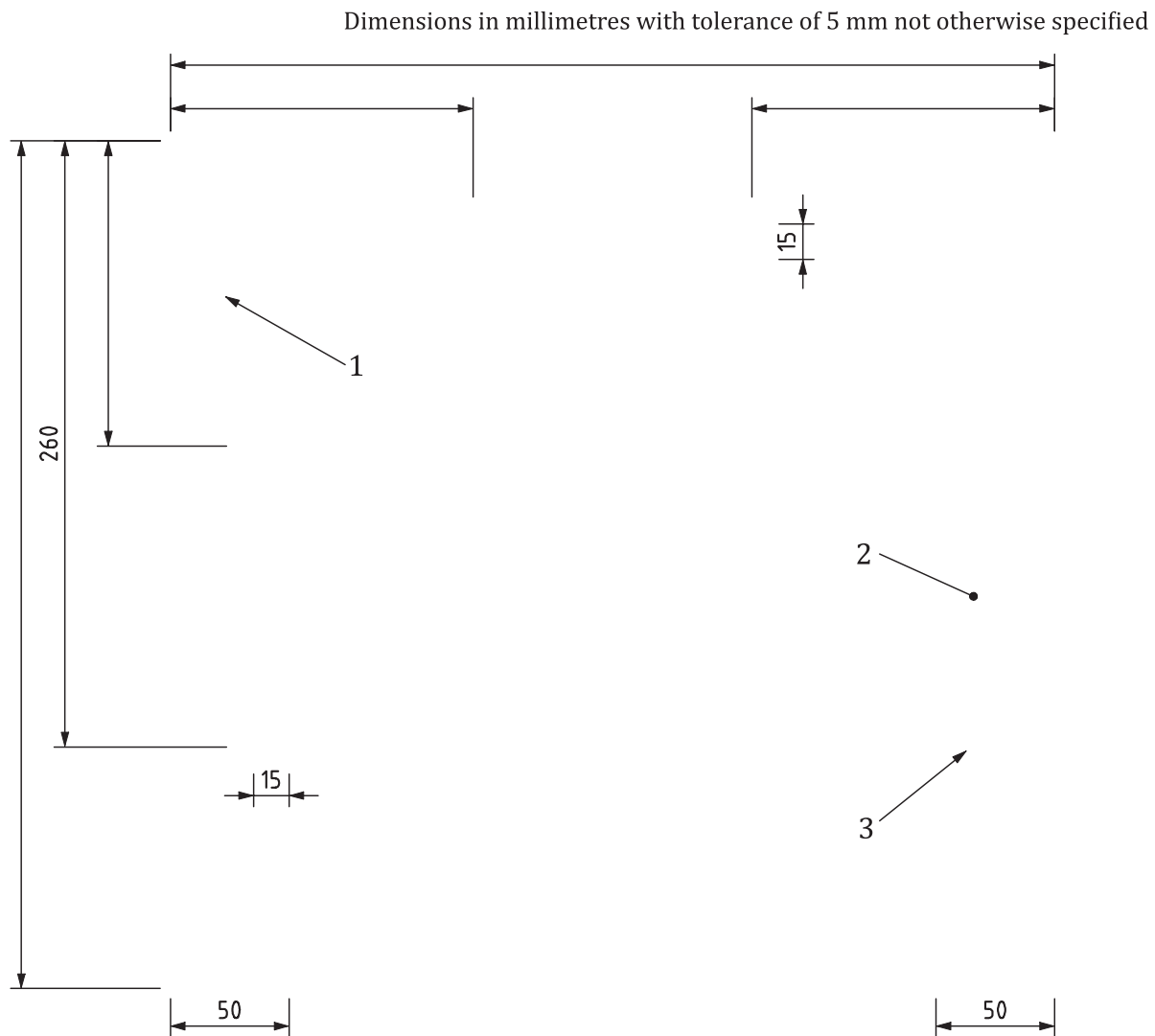

**Key**

- |   |                                       |   |   |
|---|---------------------------------------|---|---|
| 1 | steel spring clip                     | 3 | diameter of hole to be determined by bolt or clump size |
| 2 | 3,5 mm + 0,1 mm thick aluminium plate |   |   |

**Figure 4 — Specimen hold-down plate**

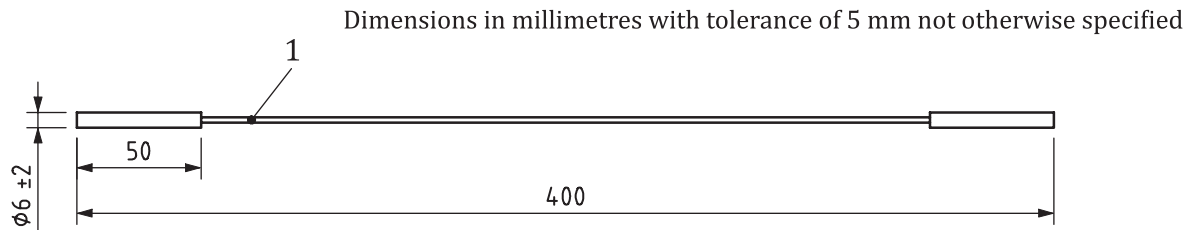
**Key**

- 1 stainless-steel rod (diameter 2 mm + 0,5 mm)

**Figure 5 — Marker rod****6.4 Marker rods**

The marker rods shall be made of stainless-steel, and have a diameter of 2,0 mm  $\pm$  0,5 mm as described in [Figure 5](#).

**6.5 Gas burner**

The gas burner specified in ISO 11925-2 shall be used.

**6.6 Fuel gas**

The fuel gas shall be propane of 95 % minimum purity. In order to obtain flame stability with the burner, the gas pressure should be between 10 kPa and 50 kPa.

Approximate heat content, gas flow rate and line-back pressure to obtain the test flame are described in [Table 1](#).

**Table 1 — Gas sources**

Gas	Approximate heat content	Flow rate	Line back-pressure <sup>a</sup>
	MJ/m <sup>3</sup>	ml/min	mmH <sub>2</sub> O column
Propane	94 $\pm$ 2	62 $\pm$ 15	25 $\pm$ 5

<sup>a</sup> The needle valve of the burner shall be adjusted to provide the line back-pressure indicated.

**6.7 Manometer and gas flow meter**

The manometer or pressure gauge and gas flow meter shall be calibrated for the gas used and capable of reading the values shown in [Table 1](#).

**6.8 Timing device**

The timing device shall have a resolution of at least to 1 s. Two timing devices are required to conduct the test.

**6.9 Measuring scale**

The measuring instrument shall be graduated in millimetres to measure the length, width and thickness of the test specimen and the height of the test flame.

## 6.10 Marker (permanent)

The marker to make marking lines on the specimens should have a fine point and use quick drying ink/paint.

## 6.11 Micrometer

The micrometer shall have a resolution of at least 0,02 mm for measuring the thickness of the specimens.

# 7 Test specimens

## 7.1 Extended application

**7.1.1** It is possible that the results of tests carried out on test specimens, taken from materials of different densities, colours and thicknesses, will be different. For materials with properties which vary over a range, the test specimens shall be representative of the whole range.

**7.1.2** Test specimens with densities at the extremes of the range shall be tested and, if the test results yield the same flame test classification, all specimens within the range shall be considered representative of the range. If the burning characteristics are not essentially the same, the results of the evaluation shall be considered to apply only to materials with the densities tested. Additional test specimens with intermediate densities shall be tested to determine the range of applicability.

**7.1.3** Uncoloured test specimens and test specimens with the highest level of organic and inorganic pigment loading shall be tested and, if the test results yield the same flame test classification, all specimens within this colour range shall be considered representative of the range. If the burning characteristics are not essentially the same, the results of the evaluation shall be considered to apply only to materials with the pigment loadings tested. If a material contains pigments which are known to affect the flammability characteristics, specimens containing these pigments shall also be tested. Thus, the test specimens tested shall be those that:

- a) contain no colouring;
- b) contain the highest level of organic pigments;
- c) contain the highest level of inorganic pigments;
- d) contain pigments which are known to adversely affect flammability characteristics.

## 7.2 Preparation of test specimens

**7.2.1** The size of the rectangle test specimen shall be 300 mm  $\pm$  3 mm wide by 325 mm  $\pm$  3 mm long.

**7.2.2** The thickness of test specimens shall not exceed 3,0 mm.

**7.2.3** Three test specimens shall be tested. If the material is anisotropic, test three specimens in both directions.

**7.2.4** Two sets of three test specimens shall be conditioned as (23  $\pm$  2) °C and (50  $\pm$  5) % relative humidity for at least 48 h, unless material specification requires a different conditioning atmosphere.

**7.2.5** After conditioning, each test specimen shall be marked with the marker by drawing a line horizontally across the test specimen, 100 mm and 300 mm from the bottom edge (see [Figure 2](#)).

## 8 Procedure

**8.1** All test specimens shall be tested in laboratory atmospheres of 15 °C to 35 °C and 45 % to 75 % relative humidity. A test for each test specimen shall be conducted within 1 h after removal of the test specimen from the conditioning chamber. If testing is not being done within 1 h after removal from the conditioning room or chamber, the test specimen shall be placed in a sealed container until testing begins.

**8.2** Secure the test specimen on a specimen holder with the 100 mm mark at the bottom. The test specimen shall be fastened flat with no extensive wrinkles or stressing.

Fasten a test specimen of thin films to the top of the specimen holder first and then tension it downwards to produce a uniform surface.

NOTE The test specimen can be spot taped or double-sided taped in place along its edges, before the hold-down plate is installed, to maintain it in position.

**8.3** Install the marker rods on the specimen holder 10 mm  $\pm$  1 mm from the surface of the test specimen at the 100 mm and 300 mm marking.

NOTE Marker rods are not needed if the marker lines on the test specimen are not distorted or obscured during the test.

**8.4** Connect the burner to a source of the gas fuel. Ignite the burner and adjust the gas flow, so that the flame is 40 mm  $\pm$  4 mm high when the burner is oriented vertically. Allow the burner to pre-heat for 2 min. The air supply shall be such that a blue flame is obtained with a small yellow tip (see ISO 11925-2).

NOTE The propane flow rate will be approximately 62 ml/min for this flame height.

**8.5** Position the burner at 45°  $\pm$  5° to the vertical such that the top of the burner is 20 mm  $\pm$  1 mm from the bottom edge of the test specimen and located on the vertical centreline of the face of the test specimen (see [Figure 6](#)). Ensure that the edge of the test specimen bisects the flame.

NOTE An automatic or fixed alignment fixture for positioning the burner has been found to produce consistent results.

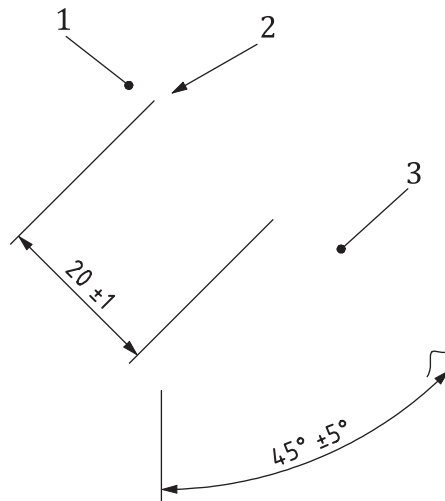

**Key**

- 1 test flame
- 2 bottom edge of specimen
- 3 burner

**Figure 6 — Position of burner and test flame**

**8.6** Smoothly apply the burner flame to the test specimen and start the timing device. Maintain the burner flame in position for a period of 60 s.

**8.7** Measure and record the time taken for the flame to reach the 100 mm and 300 mm markers as  $t_1$  and  $t_2$  respectively.

**8.8** Carry out the procedure on three test specimens. If inconsistent results, such as non-ignition of a single test specimen or cessation of flame between 100 mm and 300 mm markers on a single test specimen, are obtained, repeat the test on a second set of three test specimens. If inconsistent results are obtained on the second set, describe details in the test report.

**8.9** If, during the 60 s ignition period, the test specimen distorts away and out of reach of the flame without ignition, then, the result is not valid.



## 9 Calculation and expression of results

**9.1** Calculate the flame spread rate (FSR) in millimetres per second (mm/s) for each test specimen using [Formula \(1\)](#):

$$\text{FSR} = 200 / (t_2 - t_1) \quad (1)$$

Record FSR. If the flaming ceased between the 100 mm and 300 mm markers, record "FSR not obtained".

**9.2** Calculate the average flame spread rate ( $\text{FSR}_{\text{ave}}$ ) on FSRs of the three test specimens in millimetres per second (mm/s).

If a single test specimen in a set of three test specimens did not ignite or ceased flaming between 100 mm and 300 mm markers, then record that  $\text{FSR}_{\text{ave}}$  was obtained from two specimens.

If two test specimens in a set of three test specimens did not ignite or ceased flaming between 100 mm and 300 mm markers, then record that  $\text{FSR}_{\text{ave}}$  was not obtained.

## 10 Test report

The test report shall include the following:

- a) a statement that the test was conducted in accordance with this document, i.e. ISO 12992, and details of any alternatives, if used;
- b) the date of the test;
- c) the conditioning atmosphere used for the test specimens;
- d) all details necessary for full identification of the material tested: generic type, material designation and manufacturer;
- e) the thickness, in millimetres, for the test specimens;
- f)  $t_1$  and  $t_2$  in seconds for each test specimen;
- g) whether flaming ceased between the 100 mm and 300 mm markers;
- h) the average flame spread rate ( $\text{FSR}_{\text{ave}}$ ) (see [9.2](#));
- i) whether any flaming droplets or particles fell to the bottom of the frame and continued to flame;
- j) any observations that could have a bearing on the results of the tests.

## Annex A (informative)

### Precision data

#### A.1 General

[Table A.1](#) gives the results of an interlaboratory test conducted in 1993 involving seven laboratories testing eight materials. Two of the materials tested ceased to burn before the 300 mm marking and their flame spread rate (FSR) could not be determined. Therefore, these materials are not included in [Table A.1](#). The results were analysed using ISO 5725:1986.

[Table A.1](#) is only intended to present a meaningful way of considering the approximate precision of this test method for a range of materials. These data shall not be rigorously applied to acceptance or rejection of material, as they are specific to the interlaboratory test and may not be representative of other lots, conditions, thickness or materials.

#### A.2 Repeatability, $r$

In the normal and correct operation of the test method, the differences between two averages, determined from three specimens by one operator using identical test material and the same apparatus within a short time interval, will not exceed the repeatability value shown in [Table A.1](#) more than once in 20 cases on average.

#### A.3 Reproducibility, $R$

In the normal and correct operation of the test method, the difference between two independent averages, determined from three specimens by two operators working in different laboratories on identical test material, will not exceed the reproducibility value shown in [Table A.1](#) more than once in 20 cases on average.

#### A.4 Average

The two averages, determined from three specimens, are to be considered suspect and not equivalent if they differ by more than the repeatability and reproducibility shown in [Table A.1](#). Any judgement per [A.2](#) or [A.3](#) would have an approximately 95 % (0,95) probability of being correct.

**Table A.1 — Precision data for average FSR**

Material	PE	PE	PET	PMMA	ABS	Glass-fibre reinforced unsaturated polyester
Thickness (mm)	0,075	0,15	0,15	2,0	2,0	1,4
Average FSR (mm/s)	10,8	9,7	3,7	4,7	7,6	6,1
Repeatability	5	4,8	1,7	2	2,8	1,5
Reproducibility	7,3	5,5	4,1	4,6	7,7	2,2

## Bibliography

- [1] ISO 5725:1986<sup>1)</sup>, *Precision of test methods — Determination of repeatability and reproducibility for a standard test method by inter-laboratory tests*

---

1) Withdrawn.

