**Carbonaceous materials used in the
production of aluminium — Baked
anodes — Determination of the reactivity to
carbon dioxide —**

**Part 1:
Loss in mass method**

*Produits carbonés utilisés pour la production de l'aluminium — Anodes
cuites — Détermination de la réactivité au dioxyde de carbone —*

Partie 1: Méthode par perte de masse



Reference number
ISO 12988-1:2000(E)

© ISO 2000

PDF disclaimer

This PDF file may contain embedded typefaces. In accordance with Adobe's licensing policy, this file may be printed or viewed but shall not be edited unless the typefaces which are embedded are licensed to and installed on the computer performing the editing. In downloading this file, parties accept therein the responsibility of not infringing Adobe's licensing policy. The ISO Central Secretariat accepts no liability in this area.

Adobe is a trademark of Adobe Systems Incorporated.

Details of the software products used to create this PDF file can be found in the General Info relative to the file; the PDF-creation parameters were optimized for printing. Every care has been taken to ensure that the file is suitable for use by ISO member bodies. In the unlikely event that a problem relating to it is found, please inform the Central Secretariat at the address given below.

© ISO 2000

All rights reserved. Unless otherwise specified, no part of this publication may be reproduced or utilized in any form or by any means, electronic or mechanical, including photocopying and microfilm, without permission in writing from either ISO at the address below or ISO's member body in the country of the requester.

ISO copyright office
Case postale 56 • CH-1211 Geneva 20
Tel. + 41 22 749 01 11
Fax + 41 22 734 10 79
E-mail copyright@iso.ch
Web www.iso.ch

Printed in Switzerland

Foreword

ISO (the International Organization for Standardization) is a worldwide federation of national standards bodies (ISO member bodies). The work of preparing International Standards is normally carried out through ISO technical committees. Each member body interested in a subject for which a technical committee has been established has the right to be represented on that committee. International organizations, governmental and non-governmental, in liaison with ISO, also take part in the work. ISO collaborates closely with the International Electrotechnical Commission (IEC) on all matters of electrotechnical standardization.

International Standards are drafted in accordance with the rules given in the ISO/IEC Directives, Part 3.

Draft International Standards adopted by the technical committees are circulated to the member bodies for voting. Publication as an International Standard requires approval by at least 75 % of the member bodies casting a vote.

Attention is drawn to the possibility that some of the elements of this part of ISO 12988 may be the subject of patent rights. ISO shall not be held responsible for identifying any or all such patent rights.

International Standard ISO 12988-1 was prepared by Technical Committee ISO/TC 47, *Chemistry*, Subcommittee SC 7, *Aluminium oxide, cryolite, aluminium fluoride, sodium fluoride, carbonaceous products for the aluminium industry*.

ISO 12988 consists of the following parts, under the general title *Carbonaceous materials used in the production of aluminium — Baked anodes — Determination of the reactivity to carbon dioxide*:

— *Part 1: Loss in mass method*

A thermogravimetric method will be the subject of a future part 2 to ISO 12988.

Introduction

Carbon reacts with carbon dioxide according to the following equation:

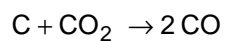

The loss of anode material from reaction with CO_2 under certain constant conditions, as well as the mass of the remaining specimen and of the dust resulting from selective burning, are of importance in predicting the behaviour of the anodes in the electrolysis cell.

Carbonaceous materials used in the production of aluminium — Baked anodes — Determination of the reactivity to carbon dioxide —

Part 1: Loss in mass method

1 Scope

This part of ISO 12988 specifies a loss in mass method for the determination of the reactivity of carbonaceous products to carbon dioxide. This method was developed especially for baked anodes used in the production of aluminium.

2 Normative references

The following normative documents contain provisions which, through reference in this text, constitute provisions of this part of ISO 12988. For dated references, subsequent amendments to, or revisions of, any of these publications do not apply. However, parties to agreements based on this part of ISO 12988 are encouraged to investigate the possibility of applying the most recent editions of the normative documents indicated below. For undated references, the latest edition of the normative document referred to applies. Members of ISO and IEC maintain registers of currently valid International Standards.

ISO 8007-2:1999, *Carbonaceous materials used in the production of aluminium — Sampling plans and sampling from individual units — Part 2: Prebaked anodes.*

IEC 60584-2, *Thermocouples — Part 2: Tolerances.*

3 Principle

A baked test cylinder is placed in a furnace purged with carbon dioxide, CO₂, at a temperature of 960 °C for 7 h. The loss in mass is determined and the dust produced is measured using a tumbling-apparatus. The residual body of the test cylinder, called the unreacted residue, is weighed and all results calculated in mass percent.

4 Reagent

4.1 Carbon dioxide, (CO₂) having a minimum purity of 99,5 % by volume and impurities of

— N₂ + Ar < 0,5 % by volume,

— H₂O < 150 mg/m³.

5 Apparatus

A diagram showing a typical apparatus in accordance with specifications is shown in Figure 1.

Normal ordinary apparatus and in particular the following:

5.1 Muffle furnace, having the dimensions given in Figure 2 with a vertical, single-zone tube ensuring good, vertical temperature distribution and capable of heating to a maximum temperature of at least 1 000 °C as well as maintaining the temperature at (960 ± 2) °C.

5.2 Sample holder, made of heat-resistant steel to support the two test specimens in the centre of the furnace with a collection plate incorporated for catching dust falling from the specimens.

An appropriate test arrangement is shown in Figure 3.

5.3 Temperature controller, consisting of a two-point temperature PID controller with a set value adjuster (adjustment error $< 0,5$ %) and with a digital temperature display.

5.4 Gas-flow meter and pressure control, consisting of a gas-flow meter calibrated for CO₂ gas and a manometer. The CO₂ gas-flow meter ($p = 0,1$ MPa) having a full-scale flow rate of 250 l/h, shall be accurate to ± 4 %. The gas pressure is adjusted using a valve to obtain the regular value, 0,2 MPa, which shall be controlled by a manometer. The full scale of the manometer shall be 0 MPa to 1 MPa. It shall be capable of introducing CO₂ into the muffle furnace and of keeping the gas-flow constant by less than ± 3 % for the duration of the test.

5.5 Thermocouple, chromel-alumel, K-type, accurate to better than 0,75 % in accordance with IEC 60584-2, having a 2,8 mm diameter with a minimum length of 400 mm.

The distance between the upper surface of the anode and the thermocouple shield shall be $(10 \pm 0,5)$ mm.

5.6 Alumina tube, covering the gas inlet tube (see Figure 1) at the bottom of the furnace and for preheating the gas.

5.7 Tumbling-apparatus, having the following components and assembled as shown in Figure 4.

5.7.1 Electric motor, 90 r/min, 220 V or 110 V, 50/60 Hz.

5.7.2 Two steel cylindrical chambers, with the following dimensions:

— internal diameter: 68 mm;

— internal height: 120 mm.

5.7.3 50 steel balls, per chamber (5.7.2), of approximately 6 mm diameter.

5.7.4 Sieve, of 4 mm aperture and pan.

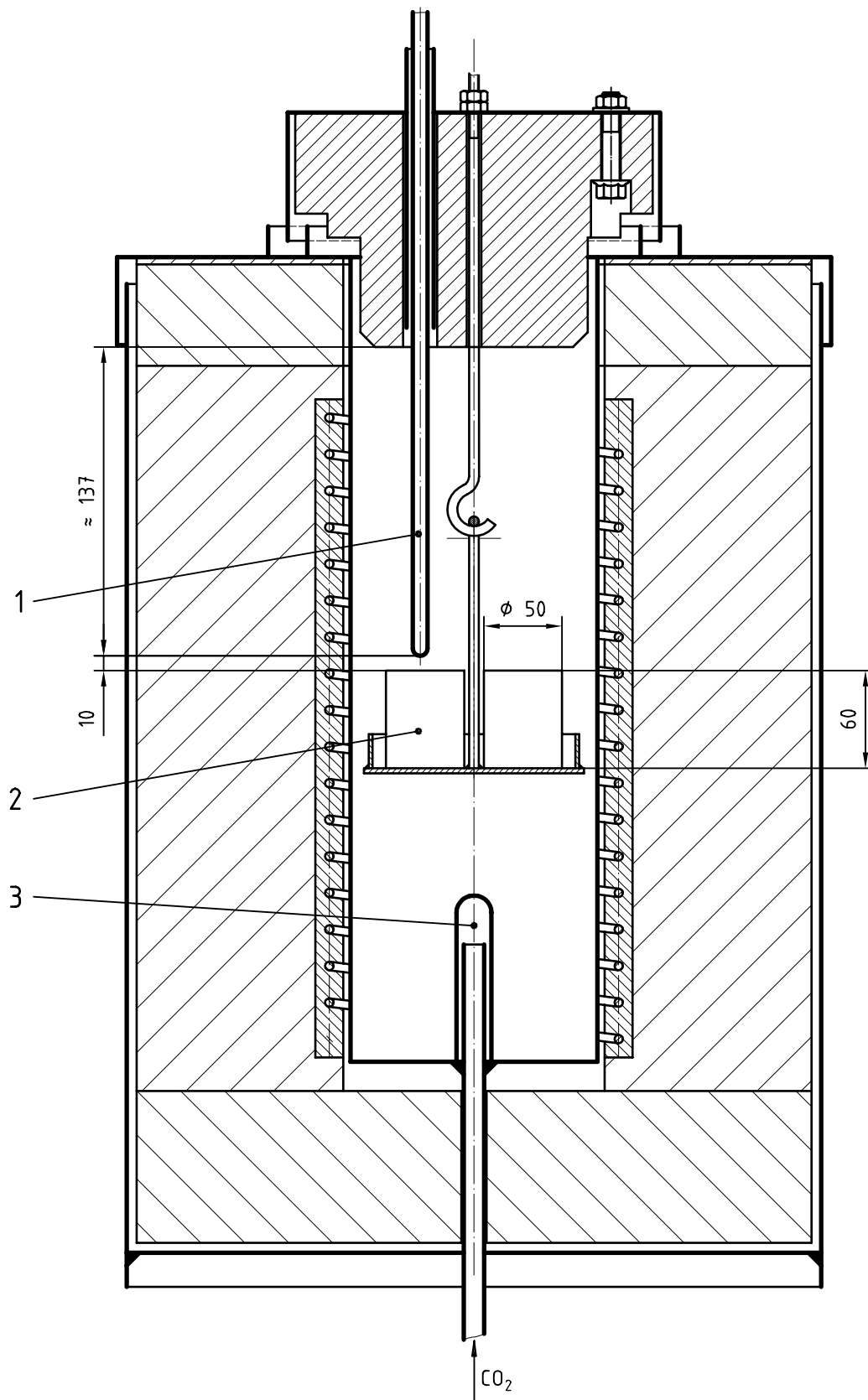

Key

- 1 Thermocouple
- 2 Test specimen
- 3 Preheater with alumina tube

Figure 1 — Schema of apparatus assembly

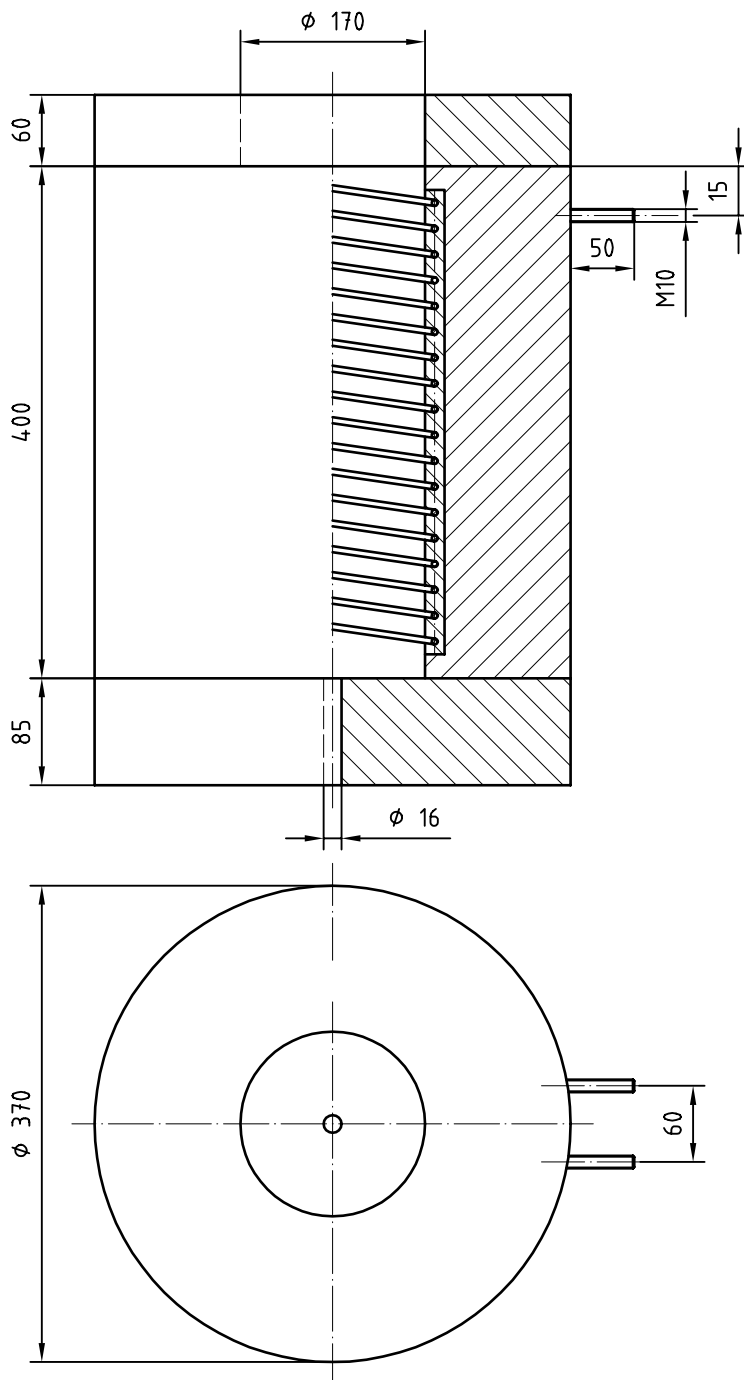

Figure 2 — Dimensions of typical muffle furnace

Dimensions in millimetres

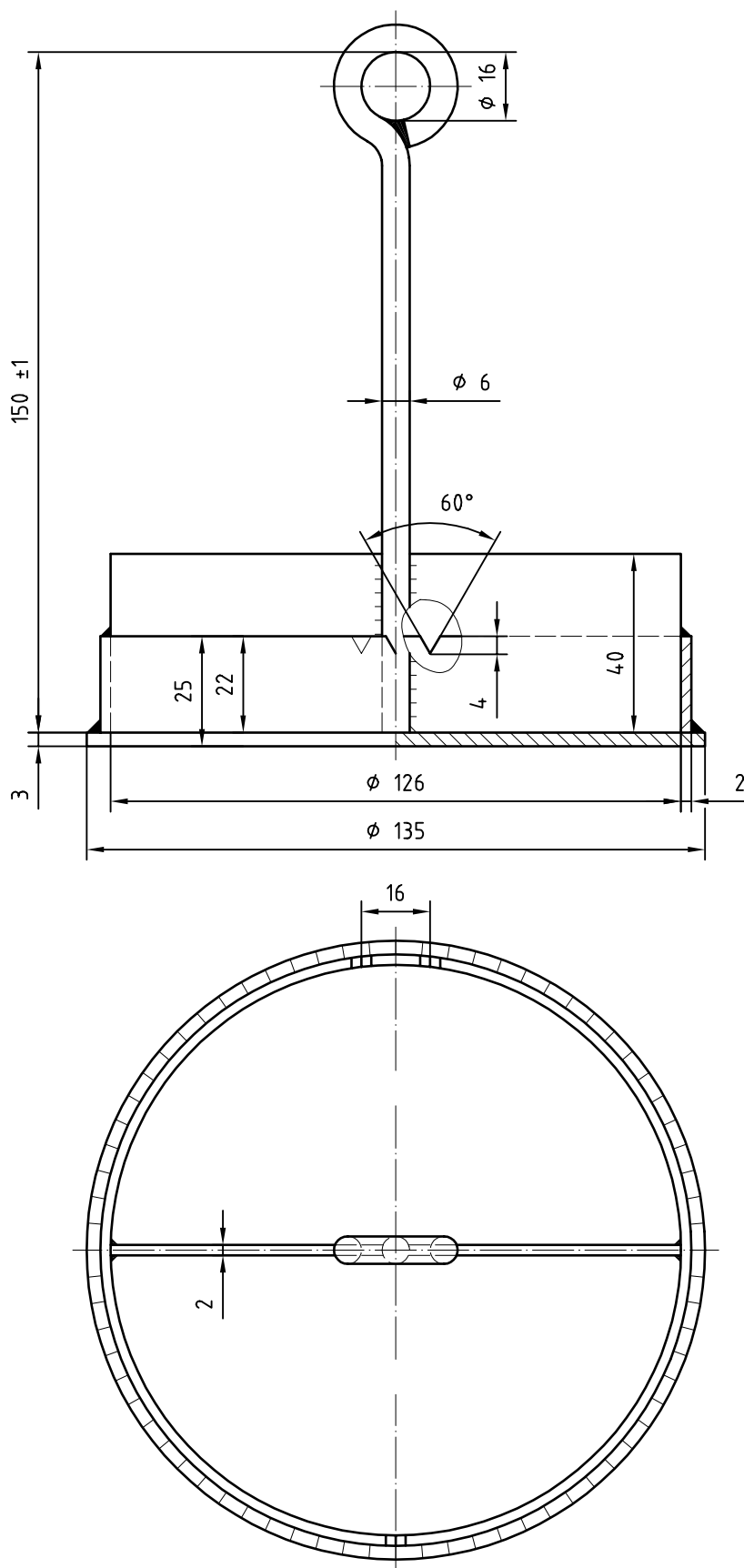
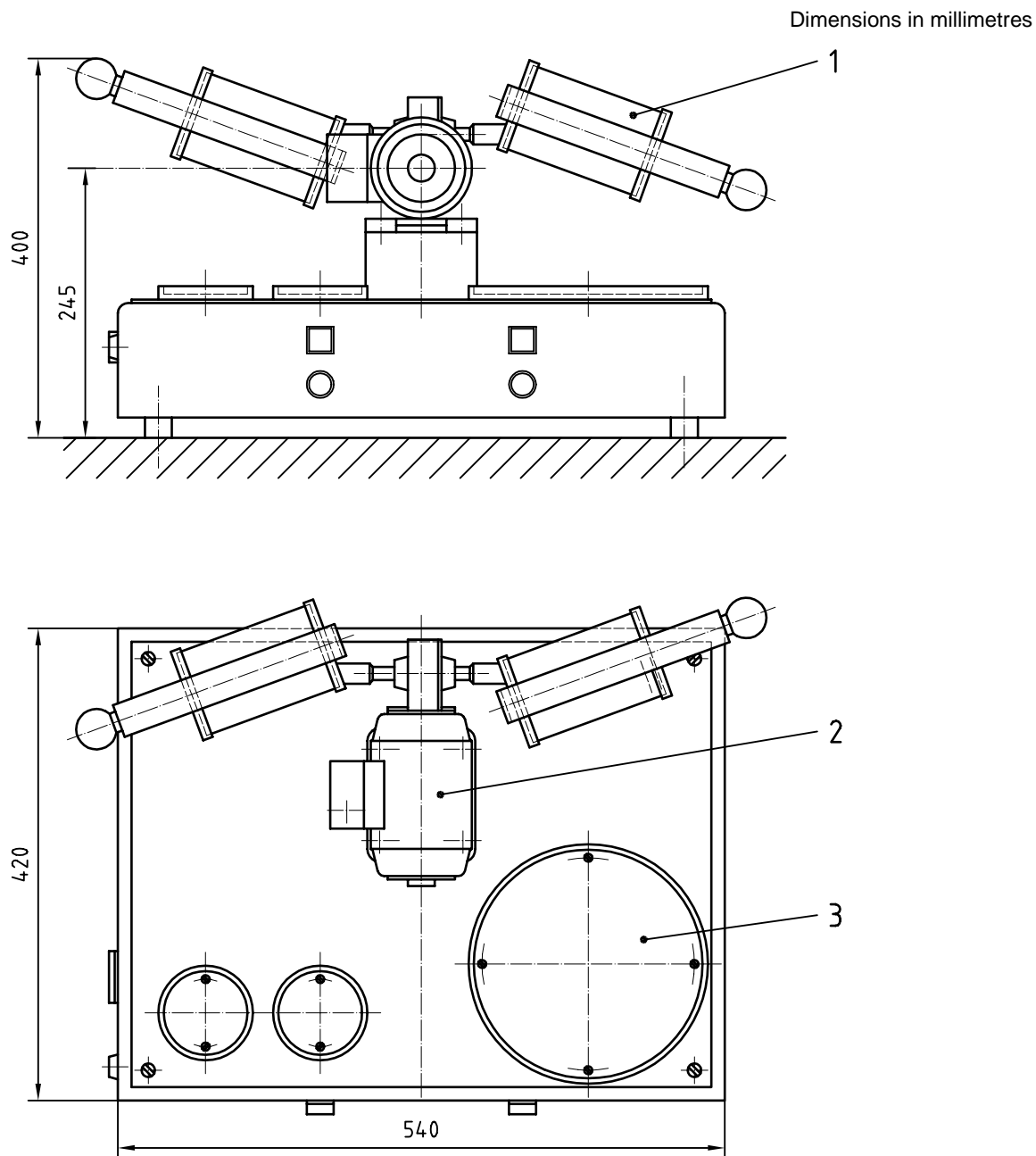

Figure 3 — Example of an arrangement for the determination of the reactivity of the anodes to CO₂



Key

- 1 Chamber
- 2 Motor
- 3 Sieve

Figure 4 — Tumbling-apparatus for determining the amount of dust produced

6 Sampling

When the test specimens (or cores) are to be extracted from a larger body, sampling shall be carried out in accordance with the procedure specified in ISO 8007-2. Alternatively, samples may be prepared in the laboratory by a bench-scale procedure.

7 Preparation of test specimens

Prepare two test specimens each with a core diameter of (50 ± 1) mm and a length of (60 ± 1) mm. Dry the specimens at (120 ± 5) °C for 12 h and cool to room temperature.

8 Procedure

Determine the initial mass of each test specimen by weighing each one (cores) (m_0) to 0,1 g. Heat the muffle furnace (5.1) to (960 ± 2) °C. Maintain the furnace at this temperature for at least 60 min to allow the temperature to stabilize, open the furnace, insert the test specimens and close the furnace. Start the gas flow of CO₂ and adjust the flow rate (see 5.4) through the alumina tube (5.6) to 200 l/h. Maintain the furnace at 960 °C and the gas flow at 200 l/h for 7 h. After 7 h, switch off the furnace and after an additional 2 h cooling, switch off the gas flow. Once the temperature of the furnace falls below 550 °C, remove the residual body of the test specimen and the dust produced.

Allow the residual body of the test specimen (cores) and the dust to cool to room temperature and weigh them (m_1) to the nearest 0,1 g. Place each residual test specimen (core) in a separate chamber (5.7.2) of the tumbling-apparatus with 50 steel balls (5.7.3) and allow them to tumble for 20 min to remove any loose particles. Once the tumbling has been completed, empty the chamber into the 4 mm sieve (5.7.4), remove the balls, then weigh the residual bodies of the test specimens (cores) to the nearest 0,1 g (m_2).

9 Expression of results

Determine the reactivity-to-CO₂ parameters, w_{RC} (residue, dust and loss), expressed as a percentage by mass, using the following formulae:

$$\text{Residue, } w_{RCR}: \quad w_{RCR} = \frac{m_2}{m_0} \times 100$$

$$\text{Dust, } w_{RCD}: \quad w_{RCD} = \frac{m_1 - m_2}{m_0} \times 100$$

$$\text{Loss, } w_{RCL}: \quad w_{RCL} = \frac{m_0 - m_1}{m_0} \times 100$$

where

m_0 is the initial mass, expressed in grams, of the test specimen (core);

m_1 is the mass, expressed in grams, of the residual test specimen (core) and dust;

m_2 is the mass, expressed in grams, of the residual test specimen (core) after tumbling.

Report the result to 0,1 g.

10 Precision

10.1 Repeatability

The repeatability of the test depends strongly on the homogeneity of the tested cores and is therefore difficult to assess.

10.2 Reproducibility

In 1993, samples were tested in over 20 laboratories which has allowed an estimate of the reproducibility, R , of the test to be made (see Figure 5) as a function of the level of the reactivity-to-CO₂. These reproducibility figures can be used when the average of at least 30 cores is determined to characterize a given electrode population.

11 Test report

The test report shall include the following information:

- a) an identification of the sample;
- b) the method used with reference to this part of ISO 12988, i.e. 12988-1:1999;
- c) the method of sample preparation.
- d) the date of the test;
- e) the results and the method of expression used;
- f) any unusual features noted during the determination;
- g) any operation not included in this part of ISO 12988 or in the International Standard or in the International Standards to which reference is made, or regarded as optional;

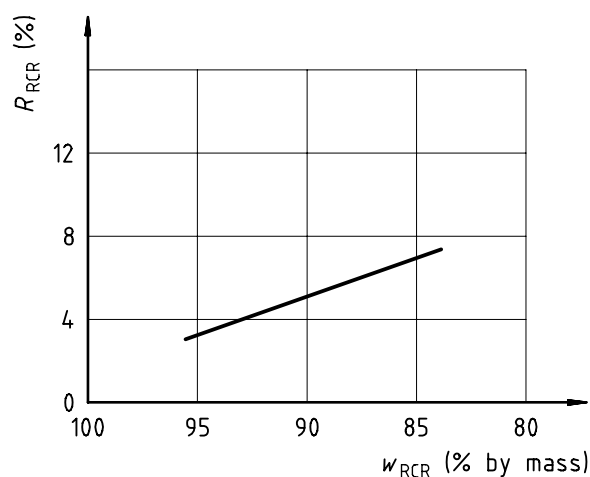

a) Estimated reproducibility R_{RCR} as a function of w_{RCR} (reactivity-to- CO_2 parameter for residue)

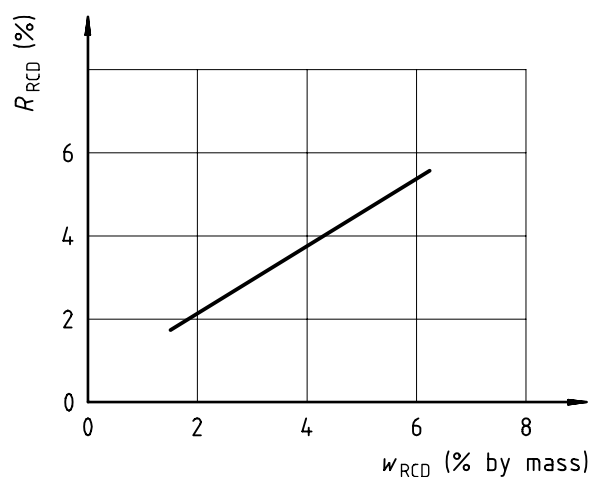

b) Estimated reproducibility R_{RCD} as a function of w_{RCD} (reactivity-to- CO_2 parameter for dust)

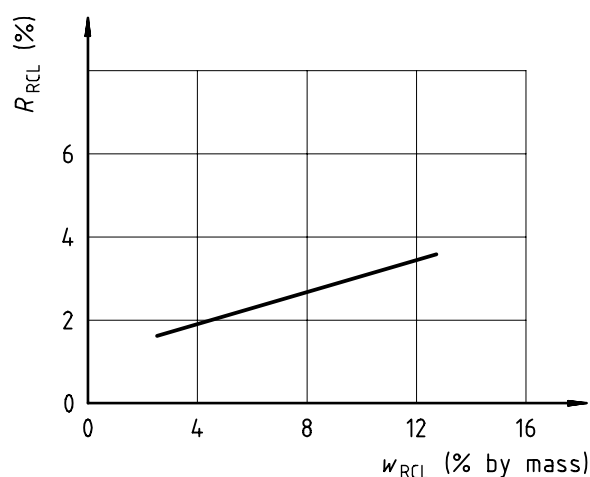

c) Estimated reproducibility R_{RCL} as a function of w_{RCL} (reactivity-to- CO_2 parameter for loss)

Figure 5 — Estimated reproducibility, R_{RCi} , as a function of the reactivity-to- CO_2 parameter, w_{RC}

ICS 71.100.10

Price based on 9 pages

© ISO 2000 – All rights reserved