**Carbonaceous materials used in the
production of aluminium — Calcined
coke — Determination of the reactivity
to carbon dioxide —**

**Part 1:
Loss in mass method**

*Produits carbonés utilisés pour la production de l'aluminium —
Coke calciné — Détermination de la réactivité au dioxyde de carbone —
Partie 1: Méthode par perte de masse*



Reference number
ISO 12981-1:2000(E)

© ISO 2000

PDF disclaimer

This PDF file may contain embedded typefaces. In accordance with Adobe's licensing policy, this file may be printed or viewed but shall not be edited unless the typefaces which are embedded are licensed to and installed on the computer performing the editing. In downloading this file, parties accept therein the responsibility of not infringing Adobe's licensing policy. The ISO Central Secretariat accepts no liability in this area.

Adobe is a trademark of Adobe Systems Incorporated.

Details of the software products used to create this PDF file can be found in the General Info relative to the file; the PDF-creation parameters were optimized for printing. Every care has been taken to ensure that the file is suitable for use by ISO member bodies. In the unlikely event that a problem relating to it is found, please inform the Central Secretariat at the address given below.

© ISO 2000

All rights reserved. Unless otherwise specified, no part of this publication may be reproduced or utilized in any form or by any means, electronic or mechanical, including photocopying and microfilm, without permission in writing from either ISO at the address below or ISO's member body in the country of the requester.

ISO copyright office
Case postale 56 • CH-1211 Geneva 20
Tel. + 41 22 749 01 11
Fax + 41 22 749 09 47
E-mail copyright@iso.ch
Web www.iso.ch

Printed in Switzerland

Contents

Page

Foreword.....	iv
Introduction	v
1 Scope	1
2 Normative references	1
3 Principle.....	1
4 Reagent.....	1
5 Apparatus	2
6 Sampling.....	5
7 Preparation of test sample.....	6
8 Procedure	6
9 Expression of results	7
10 Precision.....	7
11 Test report	7

Foreword

ISO (the International Organization for Standardization) is a worldwide federation of national standards bodies (ISO member bodies). The work of preparing International Standards is normally carried out through ISO technical committees. Each member body interested in a subject for which a technical committee has been established has the right to be represented on that committee. International organizations, governmental and non-governmental, in liaison with ISO, also take part in the work. ISO collaborates closely with the International Electrotechnical Commission (IEC) on all matters of electrotechnical standardization.

International Standards are drafted in accordance with the rules given in the ISO/IEC Directives, Part 3.

Draft International Standards adopted by the technical committees are circulated to the member bodies for voting. Publication as an International Standard requires approval by at least 75 % of the member bodies casting a vote.

Attention is drawn to the possibility that some of the elements of this part of ISO 12981 may be the subject of patent rights. ISO shall not be held responsible for identifying any or all such patent rights.

International Standard ISO 12981-1 was prepared by Technical Committee ISO/TC 47, *Chemistry*, Subcommittee SC 7, *Aluminium oxide, cryolite, aluminium fluoride, sodium fluoride, carbonaceous products for the aluminium industry*.

ISO 12981 consists of the following parts, under the general title *Carbonaceous materials used in the production of aluminium — Calcined coke — Determination of the reactivity to carbon dioxide*:

- *Part 1: Loss in mass method*
- *Part 2: Thermogravimetric method*

Introduction

The reactivity of a calcined coke to carbon dioxide is assessed by determining the loss in mass of a sample exposed in accordance with the following chemical reaction:

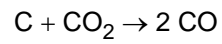

This determination allows an assessment of the later anode reactivity to carbon dioxide in the electrolysis cell.

Carbonaceous materials used in the production of aluminium — Calcined coke — Determination of the reactivity to carbon dioxide —

Part 1: Loss in mass method

1 Scope

This part of ISO 12981 specifies a method for the determination, by a loss in mass method, of the reactivity of calcined petroleum coke, used in the manufacture of anodes for the production of aluminium, to carbon dioxide.

2 Normative references

The following normative documents contain provisions which, through reference in this text, constitute provisions of this part of ISO 12981. For dated references, subsequent amendments to, or revisions of, any of these publications do not apply. However, parties to agreements based on this part of ISO 12981 are encouraged to investigate the possibility of applying the most recent editions of the normative documents indicated below. For undated references, the latest edition of the normative document referred to applies. Members of ISO and IEC maintain registers of currently valid International Standards.

ISO 383, *Laboratory glassware — Interchangeable conical ground joints.*

ISO 5725-2, *Accuracy (trueness and precision) of measurement methods and results — Part 2: Basic method for the determination of repeatability and reproducibility of a standard measurement method.*

ISO 6375, *Carbonaceous materials for the production of aluminium — Coke for electrodes — Sampling.*

ISO 8723, *Carbonaceous materials for the production of aluminium — Calcined coke — Determination of oil content — Method by solvent extraction.*

ISO 12984, *Carbonaceous materials used in the production of aluminium — Calcined coke — Determination of particle size distribution.*

3 Principle

A coke sample of 5 g having a grain size of 1 mm to 1,4 mm is exposed to a carbon dioxide (CO₂) stream of 50 l/h for approximately 100 min at 1 000 °C. The loss in mass is then measured.

4 Reagents

4.1 CO₂, having a minimum purity of 99,9 % by volume and maximum impurity levels of

- O₂: 100 µmol/mol,
- H₂O: 130 µmol/mol,
- N₂ + Ar: 800 µmol/mol.

4.2 Calibration standard, certified with a precisely known value of reactivity to carbon dioxide of about 10 % by mass.

NOTE Suitable materials are commercially available.

5 Apparatus

A diagram of a complete apparatus is shown in Figure 1.

5.1 Ordinary laboratory apparatus.

5.2 Furnace, with a vertical, single-zone tube ensuring good vertical temperature distribution and capable of heating from 20 °C to 1 000 °C in less than 1 h and maintaining the temperature at $(1\ 000 \pm 3)$ °C.

The characteristics and dimensions of a typical furnace are shown in Figure 2.

5.3 Tube reactor, consisting of two quartz tubes and a cap, with ground-glass joints (ISO 383, NS 29/32).

The characteristics and dimensions of a typical tube reactor assembly are shown in Figure 3 with the following components:

5.3.1 External tube, containing

- a) a gas inlet, positioned at the top of the external tube, allowing the gas to flow down to the bottom of the tube and to be preheated before flowing up through the coke bed;
- b) a protection tube for the thermocouple positioned so that the tip of the thermocouple lies 5 mm underneath the fritted disc.

The bottom of the thermocouple protection tube and the gas inlet shall be external to the furnace.

5.3.2 Inner reaction tube, fitted inside the external tube.

5.3.3 Fritted disc, having a 250 mm to 500 mm pore size, fitted inside the inner reaction tube and positioned so that the base of the coke bed lies in the middle of the furnace.

5.3.4 Cap, containing a gas outlet, clamped to the top of the inner reaction tube.

5.4 Thermocouple, chromel alumel, K-type, having an accuracy of better than $\pm 0,375$ %, a diameter of 2 mm and a minimum length of 200 mm.

5.5 Temperature control unit, consisting of a two-point temperature PID controller with a set-value adjuster (adjustment error $< 0,5$ %) and with a digital temperature display. The set-point value shall be selected so that the tube reactor thermocouple indicates 1 000 °C.

5.6 Flow meter, with a calibrated scale, for the CO₂ ($p = 0,1$ MPa), having a full-scale reading of 60 l/h and an accuracy of better than ± 2 %.

5.7 Pressure control, comprising a valve to regulate the pressure, and a manometer having a scale reading from 0 MPa to 1,0 MPa.

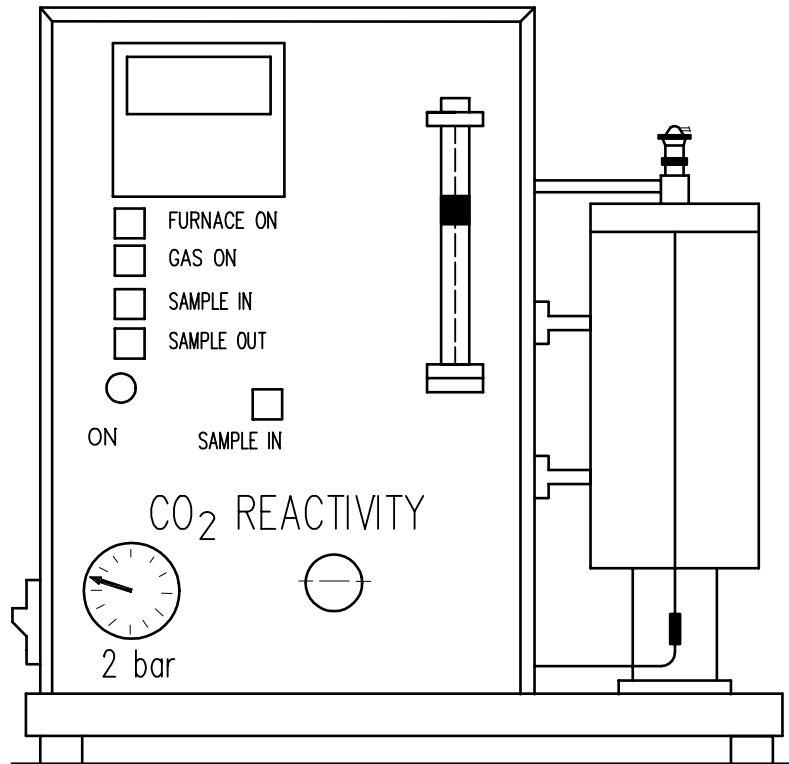

Figure 1 — CO₂ reactivity apparatus

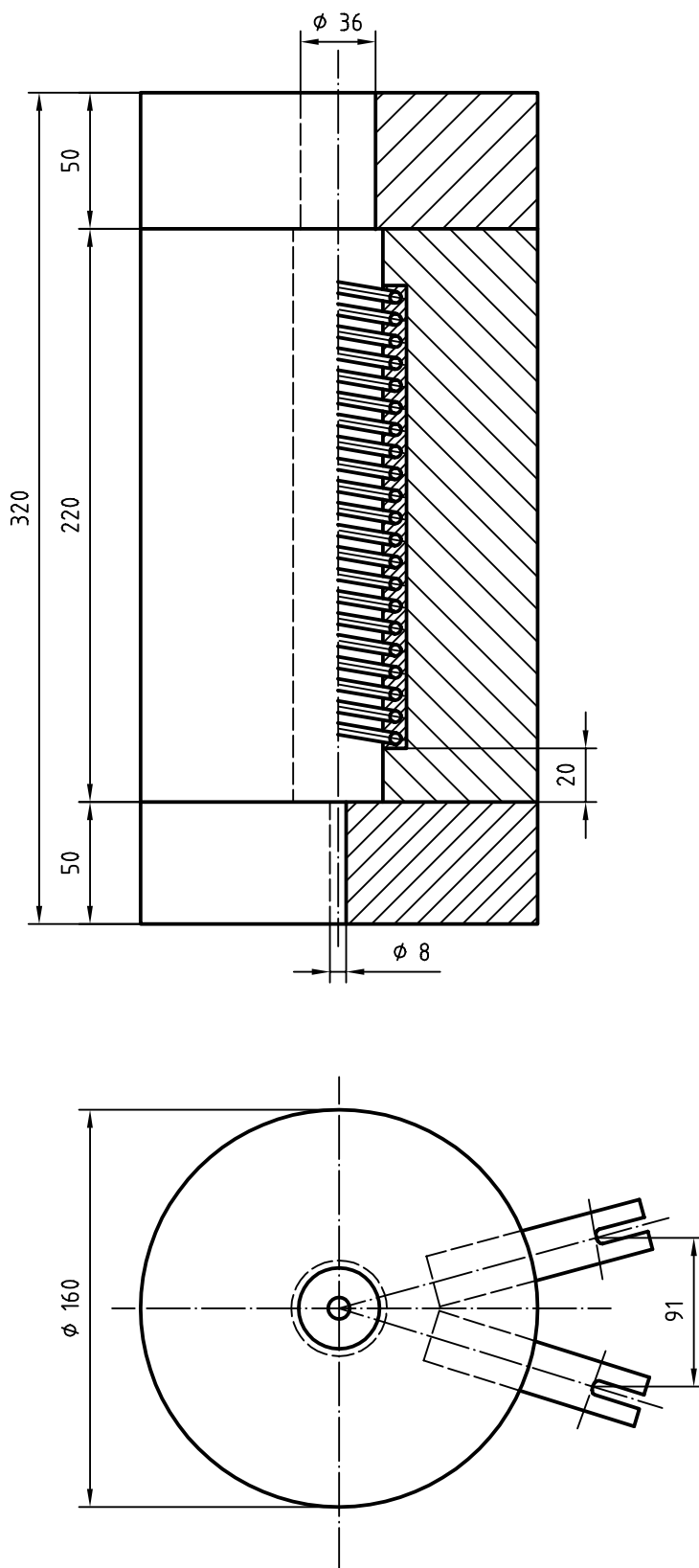
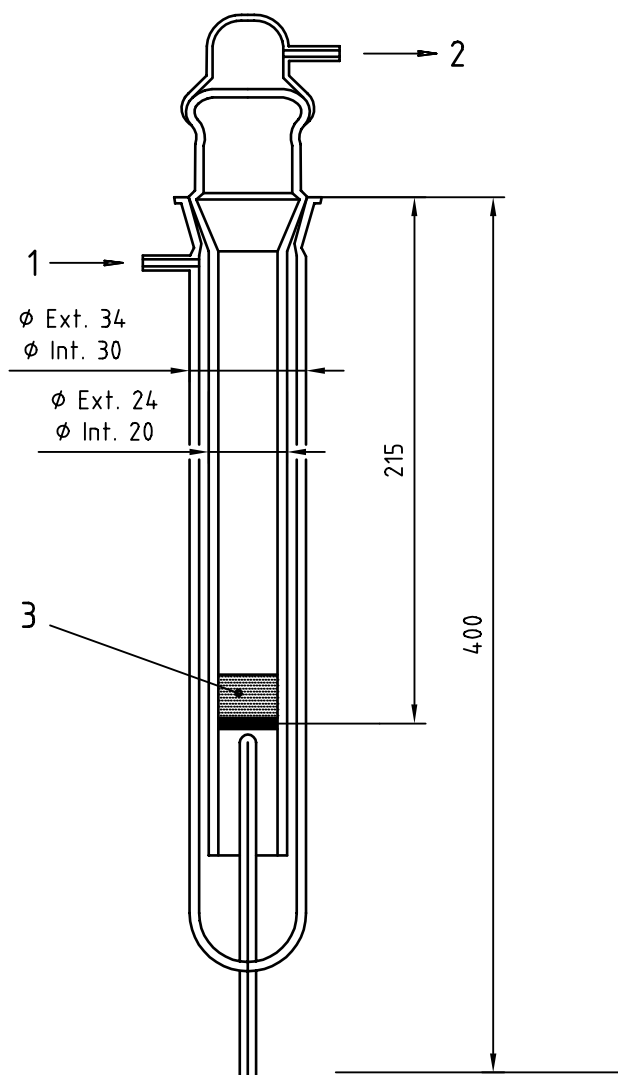

Figure 2 — Characteristics and dimensions of a typical furnace

Dimensions in millimetres



Key

- 1 CO₂ in
- 2 CO₂ out
- 3 Test sample (5 g)

Figure 3 — Tube reactor with test sample

6 Sampling

Take a sample of the coke in accordance with the procedure specified in ISO 6375.

7 Preparation of test sample

Divide the sample (see clause 6) into three fractions by sieving in accordance with ISO 12984. The fractions shall have the following dimensions:

- I > 1,4 mm;
- IIa 1 mm to 1,4 mm;
- III < 1 mm.

Crush fraction I to produce fraction IIb so that most of fraction IIb has the following dimensions after sieving:

- IIb 1 mm to 1,4 mm.

Thoroughly mix fractions IIa and IIb.

Many granular materials are coated with oil. In such cases, remove the oil from the mixture of fractions IIa and IIb with dichloromethane, using the procedure specified in ISO 8723.

Dry the mixture of fractions IIa and IIb at $(110 \pm 5) ^\circ\text{C}$ to constant mass, i.e. until consecutive weighings at 5 min intervals differ by less than 0,1 %.

Take a test sample of $(5 \pm 0,01)$ g from the mixture of fractions IIa and IIb and weigh it to the nearest 0,001 g.

8 Procedure

8.1 Calibration

Calibrate the apparatus once a week and after any maintenance of the apparatus, for instance replacement of the reaction tube or thermocouple. Set the reaction time to 100 min.

Carry out two measurements using the calibration standard (4.2) and calculate the average result (see clause 9). Calibrate the apparatus by calculating the reaction time, t_r , in accordance with the following equation:

$$t_r = 100 \times \frac{w_{\text{RC,cal}}}{w_{\text{RC,meas}}}$$

where

$w_{\text{RC,cal}}$ is the certified value of the reactivity of the calibration standard, expressed as a mass fraction in percent;

$w_{\text{RC,meas}}$ is the measured value of the reactivity of the calibration standard to carbon dioxide, expressed as a mass fraction in percent.

8.2 Determination

Switch on the furnace and set the temperature control unit (5.5) to $1\,000 ^\circ\text{C}$. Insert the empty inner reaction quartz tube (5.3.2) and fix the cover with the clamp. Open the CO_2 gas valve and regulate the pressure to 0,2 MPa and the flow rate to 50 l/h. When the furnace temperature has stabilized to $(1\,000 \pm 3) ^\circ\text{C}$, insert the weighed test sample into the reaction tube. After the reaction time has passed, switch off the furnace. After a further 30 min, stop the CO_2 gas, remove the reaction tube, and place it in a holder to cool. When the reaction tube has cooled, weigh the remaining test sample to the nearest 0,001 g.

9 Expression of results

Calculate the value of the reactivity to carbon dioxide w_{RC} , expressed as a mass fraction in percent, in accordance with the following formula:

$$w_{RC} = \frac{m_0 - m_1}{m_0} \times 100$$

where

m_0 is the initial mass, expressed in grams, of the test sample before reaction with carbon dioxide;

m_1 is the final mass, expressed in grams, of the test sample after reaction with carbon dioxide.

10 Precision

10.1 Interlaboratory study

A series of tests were carried out in accordance with ISO 5725-2 to determine the precision data. In 1993 samples were tested in over 20 laboratories, giving the following results.

10.2 Repeatability

The difference between the values of duplicate determinations, carried out in rapid succession by the same operator using the same apparatus on the same laboratory sample, is not expected to exceed the following repeatability limit

$$r = 7 \% \text{ (relative)}$$

10.3 Reproducibility

The difference between the values of the average of duplicate determinations obtained with two laboratories using this method for the analysis of the same laboratory sample is not expected to exceed the following reproducibility limit

$$R = 15 \% \text{ (relative)}$$

11 Test report

The test report shall include the following information:

- a) an identification of the sample;
- b) the method used with reference to this part of ISO 12981;
- c) the date of the test and the results, expressed in accordance with clause 9;
- d) any unusual features noted during the determination;
- e) any operation not included in this part of ISO 12981 or in the International Standards to which reference is made, or regarded as optional;
- f) the name and address of the certifying organization for the calibration standard.

1

ICS 71.100.10

Price based on 7 pages

© ISO 2000 – All rights reserved