

---

---

**Textiles — Assessment of the ignitability  
of bedding items —**

Part 2:

**Ignition source: match-flame equivalent**

*Textiles — Évaluation de l'allumabilité des articles de literie —*

*Partie 2: Source d'allumage: flamme simulant une allumette*



**PDF disclaimer**

This PDF file may contain embedded typefaces. In accordance with Adobe's licensing policy, this file may be printed or viewed but shall not be edited unless the typefaces which are embedded are licensed to and installed on the computer performing the editing. In downloading this file, parties accept therein the responsibility of not infringing Adobe's licensing policy. The ISO Central Secretariat accepts no liability in this area.

Adobe is a trademark of Adobe Systems Incorporated.

Details of the software products used to create this PDF file can be found in the General Info relative to the file; the PDF-creation parameters were optimized for printing. Every care has been taken to ensure that the file is suitable for use by ISO member bodies. In the unlikely event that a problem relating to it is found, please inform the Central Secretariat at the address given below.



**COPYRIGHT PROTECTED DOCUMENT**

© ISO 2010

All rights reserved. Unless otherwise specified, no part of this publication may be reproduced or utilized in any form or by any means, electronic or mechanical, including photocopying and microfilm, without permission in writing from either ISO at the address below or ISO's member body in the country of the requester.

ISO copyright office  
Case postale 56 • CH-1211 Geneva 20  
Tel. + 41 22 749 01 11  
Fax + 41 22 749 09 47  
E-mail [copyright@iso.org](mailto:copyright@iso.org)  
Web [www.iso.org](http://www.iso.org)

Published in Switzerland

# Contents

Page

Foreword .....	iv
Introduction.....	v
1 Scope .....	1
2 Normative references .....	1
3 Terms and definitions .....	2
4 Principle.....	2
5 Criteria of ignition.....	2
6 Health and safety of operators.....	3
7 Apparatus .....	3
8 Cleansing.....	5
9 Atmospheres for conditioning and testing.....	5
10 Test specimens.....	6
11 Test procedures.....	6
12 Final examination .....	10
13 Test report .....	10
Annex A (informative) Recommended gas flow control .....	11

## Foreword

ISO (the International Organization for Standardization) is a worldwide federation of national standards bodies (ISO member bodies). The work of preparing International Standards is normally carried out through ISO technical committees. Each member body interested in a subject for which a technical committee has been established has the right to be represented on that committee. International organizations, governmental and non-governmental, in liaison with ISO, also take part in the work. ISO collaborates closely with the International Electrotechnical Commission (IEC) on all matters of electrotechnical standardization.

International Standards are drafted in accordance with the rules given in the ISO/IEC Directives, Part 2.

The main task of technical committees is to prepare International Standards. Draft International Standards adopted by the technical committees are circulated to the member bodies for voting. Publication as an International Standard requires approval by at least 75 % of the member bodies casting a vote.

Attention is drawn to the possibility that some of the elements of this document may be the subject of patent rights. ISO shall not be held responsible for identifying any or all such patent rights.

ISO 12952-2 was prepared by the European Committee for Standardization (CEN) Technical Committee CEN/TC 248, *Textiles and textile products*, in collaboration with Technical Committee ISO/TC 38, *Textiles*, in accordance with the Agreement on technical cooperation between ISO and CEN (Vienna Agreement).

This second edition cancels and replaces ISO 12952-3:1998 and ISO 12952-4:1998, which have been technically revised.

ISO 12952 consists of the following parts, under the general title *Textiles — Assessment of the ignitability of bedding items*:

- *Part 1: Ignition source: smouldering cigarette*
- *Part 2: Ignition source: match-flame equivalent*

## Introduction

Fires are sometimes caused by the ignition of bedding items by smokers' materials. The ignitability of bedding items by a smouldering cigarette or a small open flame is therefore an important feature in the assessment of the risk of fire.

It cannot be assumed that protection against a smouldering ignition source will automatically give protection against flaming ignition. Users of this part of ISO 12952 should therefore consider the need to submit test specimens to both cigarette and flaming ignition tests.

This part of ISO 12952 describes test methods with a match-flame equivalent as the ignition source. Testing against the ignition source of a smouldering cigarette is covered in ISO 12952-1.

This part of ISO 12952 can be used for the assessment of ignitability of individual items of bedding and of composite arrangements.



# Textiles — Assessment of the ignitability of bedding items —

## Part 2: Ignition source: match-flame equivalent

**WARNING** — This test relates only to the ignitability of materials under the particular conditions of testing. It is not intended as a means of assessing the full potential fire hazard of the bedding item in use. Particular attention is drawn to the possibility of ignition of lower parts of a bedding assembly when using bedding items which are not themselves ignited. The performance of beds and mattresses requires reference to testing and performance standards other than those described in this part of ISO 12952.

### 1 Scope

This part of ISO 12952 specifies tests for assessing the ignitability of all bedding items when subjected to a match-flame equivalent.

This part of ISO 12952 applies to bedding items, which can normally be placed on a mattress, for example:

- mattress covers;
- underlays;
- incontinence sheets and pads;
- sheets;
- blankets;
- electric blankets;
- quilts (duvets) and covers;
- pillows (whatever the filling) and bolsters;
- pillowcases.

This part of ISO 12952 does not apply to mattresses, bed bases and mattress pads.

### 2 Normative references

The following referenced documents are indispensable for the application of this document. For dated references, only the edition cited applies. For undated references, the latest edition of the referenced document (including any amendments) applies.

ISO 3175-2 *Textiles — Professional care, drycleaning and wetcleaning of fabrics and garments — Part 2: Procedure for testing performance when cleaning and finishing using tetrachloroethene*

ISO 3175-3, *Textiles — Professional care, drycleaning and wetcleaning of fabrics and garments — Part 3: Procedure for testing performance when cleaning and finishing using hydrocarbon solvents*

## ISO 12952-2:2010(E)

ISO 3175-4, *Textiles — Professional care, drycleaning and wetcleaning of fabrics and garments — Part 4: Procedure for testing performance when cleaning and finishing using simulated wetcleaning*

ISO 4880, *Burning behaviour of textiles and textile products — Vocabulary*

ISO 6330:2000, *Textiles — Domestic washing and drying procedures for textile testing*

ISO 10528, *Textiles — Commercial laundering procedure for textile fabrics prior to flammability testing*

ISO 12952-1, *Textiles — Assessment of the ignitability of bedding items — Part 1: Ignition source: smouldering cigarette*

### 3 Terms and definitions

For the purposes of this document, the terms and definitions given in ISO 4880 and in ISO 12952-1 apply.

### 4 Principle

A test specimen placed on a testing substrate is subjected to a small open flame placed on top of and/or below the test specimen. Any progressive smouldering and/or flaming is noted.

Where the actual mattress used is known, it can replace the testing substrate.

### 5 Criteria of ignition

#### 5.1 Progressive smouldering ignition

All the types of behaviour given in a) to d) are considered to be progressive smouldering ignition:

- a) any test specimen that displays escalating combustion behaviour, making it unsafe to continue the test, and that requires forcible extinction;
- b) any test specimen that smoulders until it is consumed, within a period of 15 min following the removal of the ignition source;
- c) any test specimen that produces externally detectable amounts of smoke, heat or glowing, after a period of 15 min following the removal of the ignition source;
- d) any test specimen that, on final examination (see Clause 12), shows evidence of active smouldering.

NOTE In practice, it has been found that there is usually a clear distinction between materials which char under the influence of an ignition source, but which do not propagate further (non-progressive), and those where smouldering develops and spreads (progressive).

#### 5.2 Flaming ignition

The following types of behaviour are considered to be flaming ignition:

- a) any test specimen that displays escalating combustion behaviour, making it unsafe to continue the test, and that requires forcible extinction;
- b) any test assembly that burns until it is consumed within the test duration;
- c) any test specimen that continues to flame for more than 120 s after removal of the ignition source.

## 6 Health and safety of operators

**WARNING** — There is a considerable risk with these tests and it is essential that suitable precautions be taken, which may include the provision of breathing apparatus and protective clothing.

In the interest of safety, the tests shall be conducted in a suitable fume cupboard or purpose-built room, so that individuals are not exposed to fumes (see 7.4).

Readily accessible suitable means of extinguishing the test specimens shall be provided. Extinction of test specimens can be difficult and care should be taken to dispose of them only when they are completely inert. It can be necessary to immerse smouldering specimens in water or place them in a sealed non-combustible enclosure. To ensure complete safety, other suitable steps can be required.

## 7 Apparatus

### 7.1 Test rig

A suitable test rig is illustrated in Figure 1. It consists of a platform of open mesh of at least 450 mm × 450 mm, supported by a solid base. The test rig shall correspond to the dimensions of the test specimen, but can be larger than the test specimen.

The size of the mesh and the angle iron dimensions given in Figure 1 are not critical.

For the tests, the rig is placed within the test enclosure (see 7.4).

### 7.2 Stopwatch

A stopwatch shall be used, capable of reading to the nearest second and measuring for at least 1 h.

### 7.3 Ignition source: butane-gas flame

A burner tube made of stainless steel, of  $(8,0 \pm 0,1)$  mm outside diameter,  $(6,5 \pm 0,1)$  mm internal diameter and  $(200 \pm 5)$  mm in length, is connected by flexible tubing, via a flowmeter, fine-control valve, on-off valve and cylinder regulator providing a nominal outlet pressure of 2,8 kPa<sup>1)</sup>, to a cylinder providing commercial butane.

The flowmeter shall be calibrated to supply a nominal butane-gas flow rate at 25 °C of  $(45 \pm 1)$  ml/min. The flexible tubing connecting the output of the flowmeter to the burner tube shall be 2,5 m to 3 m in length (see also Annex A).

NOTE Under these conditions, the flame height is approximately 35 mm.

### 7.4 Test enclosure

A suitable room with a volume greater than 20 m<sup>3</sup>, which contains adequate oxygen for testing, or a smaller enclosure with a through-flow of air equipped with inlet and extraction systems shall be used. Air flow rates shall not exceed 0,2 m/s in the locality of the test specimen position. This limit provides adequate oxygen without disturbing the burning behaviour.

---

1) 1 kPa = 1 000 N/m<sup>2</sup> = 10 mbar.

### 7.5 Testing substrate

The testing substrate, which is used to simulate the mattress, over which the bedding items are tested, shall be a mineral-wool fibre pad having a thermal conductivity of 0,04 W/m·K.

The testing substrate shall correspond to the size of the test rig ( $\pm 10$  mm) and have a thickness of  $(25 \pm 5)$  mm (see Figure 2).

Dimensions in millimetres

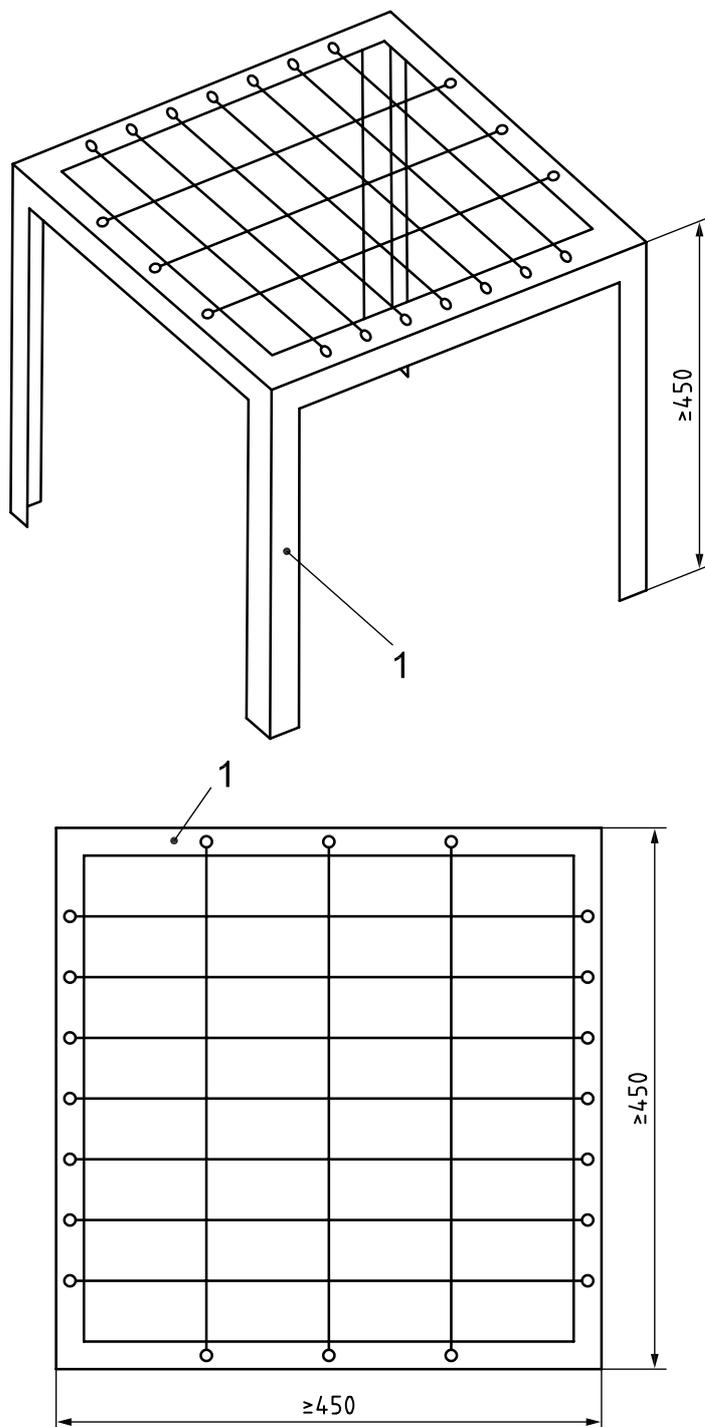

**Key**

1 angle iron

**Figure 1 — Example of a test rig**

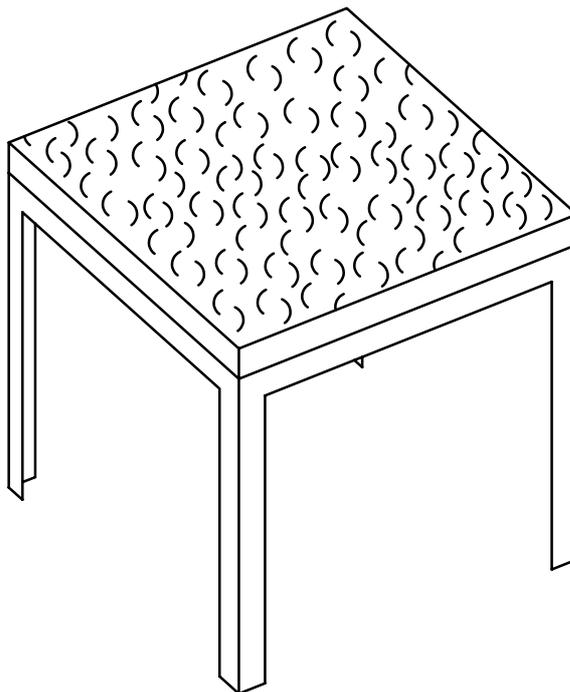

Figure 2 — Example of a test rig with testing substrate

## 8 Cleansing

The bedding items shall be washed five times using the procedure in ISO 6330 or ISO 10528, depending on their care instructions.

Materials without care instructions shall be washed five times in accordance with ISO 6330:2000, Table 1, Procedure 2A at  $(60 \pm 3)$  °C, and dried in accordance with ISO 6330:2000, 8.5, Procedure E (tumble drying at low temperatures).

Materials which are labelled “dry-clean only” shall be dry-cleaned five times in accordance with the appropriate part of ISO 3175.

Products not intended to be cleaned (single-use) shall be tested as received.

NOTE This cleansing is not intended as a life-cycle assessment of the ignitability performance of the textile product.

## 9 Atmospheres for conditioning and testing

### 9.1 Conditioning

The materials to be tested, as well as the testing substrate, shall be conditioned immediately before the test for 72 h in an atmosphere having a temperature of  $(23 \pm 2)$  °C and a relative humidity of  $(50 \pm 4)$  %.

### 9.2 Testing

For testing, a draught-free environment having a temperature of 10 °C to 30 °C and a relative humidity of 15 % to 80 % shall be used. Specimens shall be tested within 10 min of removing them from the conditioning atmosphere.

Test specimens shall be tested after cleansing, as described in Clause 8.

## 10 Test specimens

The style and design of bedding items can have a significant effect on the risk of ignition. Thus, a risk assessment should be undertaken as part of the design, taking into account factors such as the following:

- a) piped or tape-edged finish;
- b) trims;
- c) embroidery;
- d) embellishments.

Where the test specimen has features such as those detailed in a), b), c) or d), additional flame applications shall be carried out on these features.

The test specimens shall be representative of the components and make-up of the finished item.

Flat materials that will not normally be folded in use (e.g. mattress covers) shall be cut to  $(450 \pm 10) \text{ mm} \times (450 \pm 10) \text{ mm}$ .

Bolsters and pillows may be cut to a maximum length of 450 mm.

Quilts and duvets may be cut to  $(450 \pm 10) \text{ mm} \times (450 \pm 10) \text{ mm}$  (cut edges should be sealed if necessary). The test specimens shall include two original edges.

## 11 Test procedures

### 11.1 Preparation

Ensure that means of extinguishing are close at hand (see Clause 6).

Place the testing substrate on the test rig (see Figure 2) and carry out the test within 10 min of removal of the test specimen from the conditioning atmosphere (see 9.1).

Place the test specimen on the testing substrate.

The use of a template can aid the assembly of the specimen.

It is known that a minor variation in the assembly of the test specimen, for example the tightness of bedding folds, can exert a major influence on the test results.

Details of the construction of the bedding assembly are required in the test report (see Clause 13).

### 11.2 Butane flame test

Light the butane emerging from the burner tube, adjust the gas flow to the rate given in 7.3 and allow the flow to stabilize for at least 120 s.

Place the ignition source in the positions specified in 11.3. Hold the burner tube horizontally and bring it into contact with the surface of the test specimen, without any pressure and without releasing it. Leave the ignition source in position for  $(15 \pm 1) \text{ s}$  and then remove it carefully from the test specimen.

Observe the specimen for any evidence of progressive smouldering ignition or flaming ignition (see Clause 5).

**NOTE** The detection of smouldering can be difficult and is improved by watching for smoke emerging at points at a distance from the specimen. Smoke is most easily viewed by looking down a rising column by means of a mirror.

If progressive smouldering or flaming ignition of the test specimen is observed, extinguish the test specimen, note the time the test was stopped and the reason, record that ignition had occurred and discontinue testing.

If flaming ignition of the test specimen is not observed, repeat the test at a fresh position.

If progressive smouldering ignition or flaming ignition is observed in this repeat test, extinguish the test specimen, note the time the test was stopped and the reason, and record that ignition had occurred for the ignition source used.

If flaming ignition is not observed in the repeat test, continue to observe both test sites for evidence of progressive smouldering ignition. If progressive smouldering ignition is not observed, record non-ignition unless the test specimen fails the final examination described in Clause 12.

In this case, extinguish the test specimen and record that ignition has occurred.

Unless large parts of the specimen are consumed by the test, repeat tests can be carried out on the same specimen.

The second flame application shall be placed at least 100 mm away from any marks left by the previous test.

### 11.3 Set-up of test specimens and positions of ignition source

#### 11.3.1 Flat bedding items

Place the test specimen flat on the test rig with the testing substrate. Place the ignition source flat on top of the test specimen. The position of the ignition source shall be at least 100 mm away from the edges of the specimen and at least 100 mm away from any marks left by any previous test.

#### 11.3.2 Quilts

Place the test specimen flat on the test rig with the testing substrate.

Place the ignition source horizontally on top of the flat part of the quilt, at least 100 mm away from the edges.

Carry out an additional test with the ignition source placed along the line of stitching on top of the test specimen (see Figure 3).

Repeat both tests, but place the ignition source at least 100 mm away from any mark left from the previous tests.

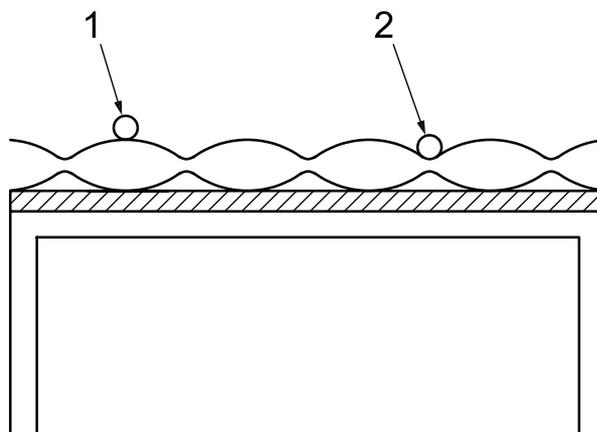

#### Key

- 1 ignition source placed horizontally on flat upper surface
- 2 ignition source placed on line of stitching

Figure 3 — Quilts: position of ignition source

### 11.3.3 Pillows/bolsters

Place the test specimen flat on the test rig with the testing substrate.

Place the ignition source horizontally on the flat upper surface of the test specimen.

Carry out an additional test with the ignition source placed horizontally ( $5 \pm 1$ ) mm below the specimen edge and with the centre line of the ignition source in the same plane as the test specimen edge (see Figure 4).

Repeat both tests, but place the ignition source at least 100 mm away from any mark left from the previous tests.

Where the item contains quilting, two additional flame applications shall be carried out on the seam, as specified in Figure 3.

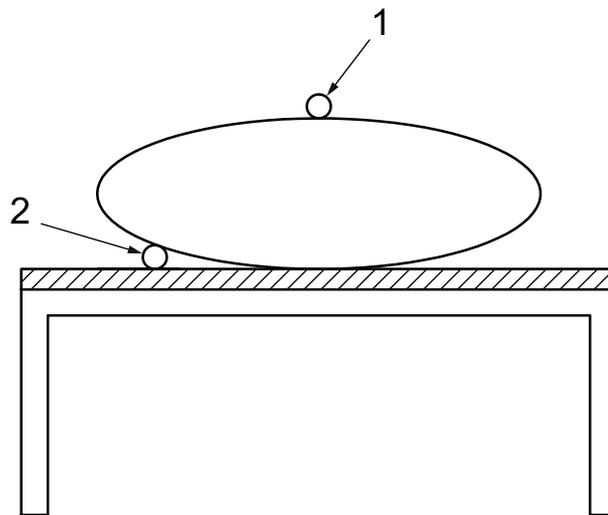

#### Key

- 1 ignition source placed horizontally on flat upper surface
- 2 ignition source placed in the same plane as pillow edge

Figure 4 — Pillows and bolsters: position of ignition source

### 11.3.4 Duvets

The test specimen shall be tested like a pillow. For the test with the ignition source placed below the test specimen, the test specimen edge shall be an original one.

Where the item contains quilting, it shall be tested like a quilt.

## 11.4 Testing of complete composites or of combinations of bedding items

### 11.4.1 Applicability

In cases where more than one or all bedding items are known, they shall be tested together because of possible interactions of the ignitability of the individual items. The relative positions of the individual items to each other during testing shall represent, as closely as possible, the actual set-up of the composite.

## 11.4.2 Set-up of testing composite arrangement

### 11.4.2.1 Dimensions of component test specimens making up the testing composite arrangement

Test specimens shall either be cut from the components in the same way and to the same size as when testing them individually, or full-sized items shall be used. If full-sized items are used, then either the test rig shall be of an appropriate size to allow the test specimens to lie as intended on a mattress, or those parts of the test specimen which protrude beyond the edges of the test rig shall be supported in the same plane at the surface of the test rig by appropriate means.

### 11.4.2.2 Positions of component test specimens and of ignition source

When a pillow (or bolster) and bed covers (blanket, quilt, duvet) are placed over the bottom sheet, incontinence sheet (if applicable) and mattress cover, the ignition source shall be placed centrally at the junction of the pillow, bottom sheet and bed covers. The bed covers shall be folded back at an angle of approximately 30° (see Figure 5). The burner tube shall be held horizontally and shall be brought into contact with the surface of the test specimens at the position shown in Figure 5, without any pressure and without releasing it.

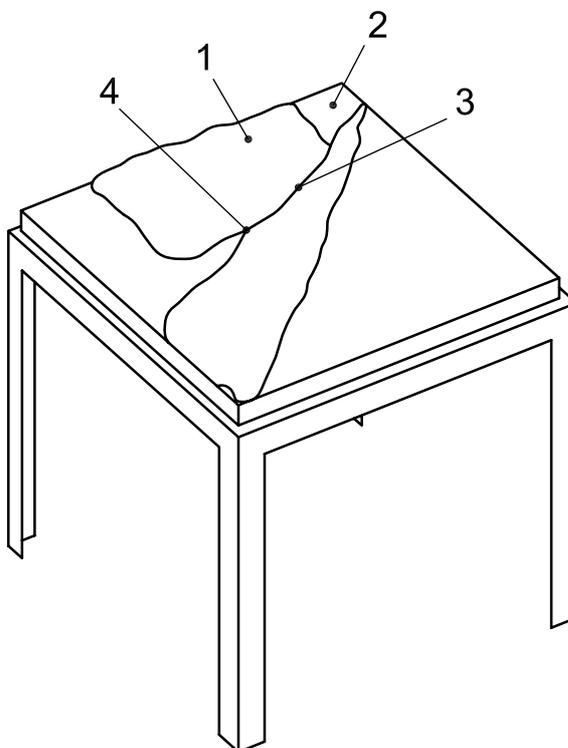

#### Key

- 1 pillow (half-scale size)
- 2 bottom sheet in position
- 3 top bed covers folded back at an angle of approximately 30°
- 4 ignition source placed centrally at junction between bottom sheet and folded-back top bed covers

**Figure 5 — Composite — Pillow and bed covers: position of ignition source**

When combinations of components are tested without a pillow, the ignition source shall be placed at the junction of the bottom sheet and the bed cover (see Figure 6).

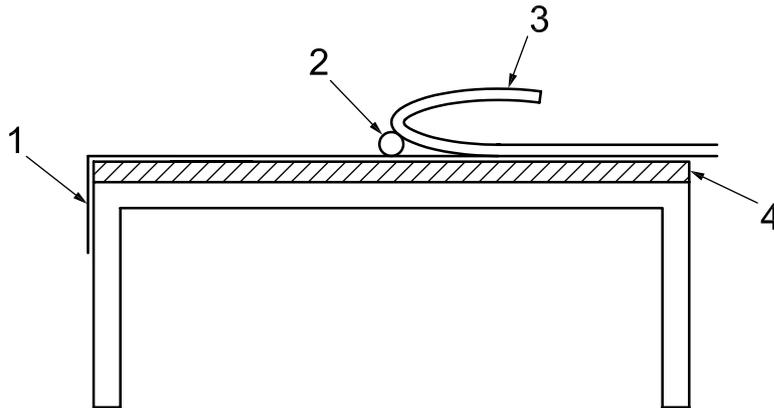

**Key**

- 1 bottom sheet
- 2 ignition source placed at junction of bottom sheet and bed cover
- 3 bed covers (folded in half)
- 4 testing substrate

**Figure 6 — Composite — Bed cover and bottom sheet: position of ignition source**

When no pillow or bed covers are used, the combination of the bottom sheet with any underlying sheet shall be tested as in 11.3.1.

## 12 Final examination

Since progressive smouldering ignition undetected from the bedding exterior may occur, dismantle the test specimen immediately after completion of the test programme and examine it internally for smouldering ignition. If this is present, extinguish the test specimen and record that ignition has occurred. For safety reasons, ensure that all smouldering ignition has ceased before the rig is left unattended.

## 13 Test report

The test report shall include the following information:

- a) the number and date of this part of ISO 12952;
- b) the following statement: "The following test results relate only to the ignitability of the tested bedding item under the particular test conditions; they are not intended as a means of assessing the full potential fire hazard of the item in use.";
- c) the identification of the tested item and any other components of the construction of the bedding assembly;
- d) the test result:
  - ignition (I) or non-ignition (NI);
  - if ignited, the type of ignition: progressive smouldering or flaming ignition;
- e) any variation from the methods described in this part of ISO 12952;
- f) the cleansing procedure used, if required;
- g) other features of burning, if required.

## **Annex A** (informative)

### **Recommended gas flow control**

Pass the gas (before flow measurement) through a metal tube immersed in water maintained at 25 °C, so that flow corrections for temperature variations can be avoided.

Great care also needs to be exercised with the measurement and setting of the gas flow rate. Direct-reading flowmeters, even those obtained with a direct gas calibration, need to be checked when initially installed, and at regular intervals during testing, by a method capable of accurately measuring the absolute gas flow at the burner tube. One way of doing this is to connect the burner tube with a short length of tubing (about 7 mm inside diameter) to a soap-bubble flowmeter, such that the upward passage of a soap-film meniscus in a glass tube of calibrated volume (e.g. a burette) over a known period of time gives an absolute measurement.

.....