

---

---

**Textiles — Assessment of the ignitability  
of bedding items —**

Part 1:

**Ignition source: smouldering cigarette**

*Textiles — Évaluation de l'allumabilité des articles de literie —*

*Partie 1: Source d'allumage: cigarette en combustion*



**PDF disclaimer**

This PDF file may contain embedded typefaces. In accordance with Adobe's licensing policy, this file may be printed or viewed but shall not be edited unless the typefaces which are embedded are licensed to and installed on the computer performing the editing. In downloading this file, parties accept therein the responsibility of not infringing Adobe's licensing policy. The ISO Central Secretariat accepts no liability in this area.

Adobe is a trademark of Adobe Systems Incorporated.

Details of the software products used to create this PDF file can be found in the General Info relative to the file; the PDF-creation parameters were optimized for printing. Every care has been taken to ensure that the file is suitable for use by ISO member bodies. In the unlikely event that a problem relating to it is found, please inform the Central Secretariat at the address given below.



**COPYRIGHT PROTECTED DOCUMENT**

© ISO 2010

All rights reserved. Unless otherwise specified, no part of this publication may be reproduced or utilized in any form or by any means, electronic or mechanical, including photocopying and microfilm, without permission in writing from either ISO at the address below or ISO's member body in the country of the requester.

ISO copyright office  
Case postale 56 • CH-1211 Geneva 20  
Tel. + 41 22 749 01 11  
Fax + 41 22 749 09 47  
E-mail [copyright@iso.org](mailto:copyright@iso.org)  
Web [www.iso.org](http://www.iso.org)

Published in Switzerland

**Contents**

Page

Foreword .....	iv
Introduction.....	v
1 Scope .....	1
2 Normative references .....	1
3 Terms and definitions .....	2
4 Principle.....	3
5 Criteria of ignition.....	3
6 Health and safety of operators.....	4
7 Apparatus .....	4
8 Cleansing.....	6
9 Atmospheres for conditioning and testing.....	6
10 Test specimens.....	7
11 Test procedures.....	7
12 Final examination .....	11
13 Test report.....	11

## Foreword

ISO (the International Organization for Standardization) is a worldwide federation of national standards bodies (ISO member bodies). The work of preparing International Standards is normally carried out through ISO technical committees. Each member body interested in a subject for which a technical committee has been established has the right to be represented on that committee. International organizations, governmental and non-governmental, in liaison with ISO, also take part in the work. ISO collaborates closely with the International Electrotechnical Commission (IEC) on all matters of electrotechnical standardization.

International Standards are drafted in accordance with the rules given in the ISO/IEC Directives, Part 2.

The main task of technical committees is to prepare International Standards. Draft International Standards adopted by the technical committees are circulated to the member bodies for voting. Publication as an International Standard requires approval by at least 75 % of the member bodies casting a vote.

Attention is drawn to the possibility that some of the elements of this document may be the subject of patent rights. ISO shall not be held responsible for identifying any or all such patent rights.

ISO 12952-1 was prepared by the European Committee for Standardization (CEN) Technical Committee CEN/TC 248, *Textiles and textile products*, in collaboration with Technical Committee ISO/TC 38, *Textiles*, in accordance with the Agreement on technical cooperation between ISO and CEN (Vienna Agreement).

This second edition cancels and replaces ISO 12952-1:1998 and ISO 12952-2:1998, which have been technically revised.

ISO 12952 consists of the following parts, under the general title *Textiles — Assessment of the ignitability of bedding items*:

- *Part 1: Ignition source: smouldering cigarette*
- *Part 2: Ignition source: match-flame equivalent*

## Introduction

Fires are sometimes caused by the ignition of bedding items by smokers' materials. The ignitability of bedding items by a smouldering cigarette or a small open flame is therefore an important feature in the assessment of the risk of fire.

It cannot be assumed that protection against a smouldering ignition source will automatically give protection against flaming ignition. Users of this part of ISO 12952 should therefore consider the need to submit test specimens to both cigarette and flaming ignition tests.

This part of ISO 12952 describes test methods with a smouldering cigarette as the ignition source. Testing against the ignition source of a small open flame is covered in ISO 12952-2.

This part of ISO 12952 can be used for the assessment of ignitability of individual items of bedding and of composite arrangements.



# Textiles — Assessment of the ignitability of bedding items —

## Part 1: Ignition source: smouldering cigarette

**WARNING** — This test relates only to the ignitability of materials under the particular conditions of testing. It is not intended as a means of assessing the full potential fire hazard of the bedding item in use. Particular attention is drawn to the possibility of ignition of lower parts of a bedding assembly when using bedding items which are not themselves ignited. The performance of beds and mattresses requires reference to testing and performance standards other than those described in this part of ISO 12952.

### 1 Scope

This part of ISO 12952 specifies test methods for assessing the ignitability of all bedding items when subjected to a smouldering cigarette.

This part of ISO 12952 applies to bedding items, which can normally be placed on a mattress, for example:

- mattress covers;
- underlays;
- incontinence sheets and pads;
- sheets;
- blankets;
- electric blankets;
- quilts (duvets) and covers;
- pillows (whatever the filling) and bolsters;
- pillowcases.

This part of ISO 12952 does not apply to mattresses, bed bases and mattress pads.

### 2 Normative references

The following referenced documents are indispensable for the application of this document. For dated references, only the edition cited applies. For undated references, the latest edition of the referenced document (including any amendments) applies.

ISO 3175-2, *Textiles — Professional care, drycleaning and wetcleaning of fabrics and garments — Part 2: Procedure for testing performance when cleaning and finishing using tetrachloroethene*

## ISO 12952-1:2010(E)

ISO 3175-3, *Textiles — Professional care, drycleaning and wetcleaning of fabrics and garments — Part 3: Procedure for testing performance when cleaning and finishing using hydrocarbon solvents*

ISO 3175-4, *Textiles — Professional care, drycleaning and wetcleaning of fabrics and garments — Part 4: Procedure for testing performance when cleaning and finishing using simulated wetcleaning*

ISO 4880, *Burning behaviour of textiles and textile products — Vocabulary*

ISO 6330:2000, *Textiles — Domestic washing and drying procedures for textile testing*

ISO 10528, *Textiles — Commercial laundering procedure for textile fabrics prior to flammability testing*

### 3 Terms and definitions

For the purposes of this document, the terms and definitions given in ISO 4880 and the following apply.

#### 3.1

##### **bed**

mattress placed on top of a bed base with no other bedding items present

#### 3.2

##### **bed assembly**

stack of successive layers of mattress and various bedding items, with or without a pillow and pillowcase, representing a section through the centre of a made-up bed

#### 3.3

##### **bed base**

structure that supports the mattress

#### 3.4

##### **bedding**

general term for all items placed on the mattress or the bed by a user to provide comfort and warmth and/or for decorative purposes, for example, sheets, blankets, bed spreads, valances, quilts, duvets, quilt covers and mattress covers

#### 3.5

##### **bolster**

long round pillow or cushion

#### 3.6

##### **duvet**

bedding item made principally from a woven material and filled, for example, with down, feathers or filling fibres

NOTE A duvet can be quilted in various ways.

#### 3.7

##### **incontinence sheet**

sheet to protect the mattress and bedding for incontinent people

#### 3.8

##### **mattress**

product in the form of a resilient material, or padding material in combination with steel springs, enveloped by a cover fabric

#### 3.9

##### **mattress cover**

secondary covering material that can be removed for laundering purposes



**3.10****mattress pad**

thin filled bedding item, usually covered with a woven material, placed on the mattress to protect it and to add to the comfort of the bed

**3.11****made-up bed**

bed prepared for use by covering with bedding items

**3.12****pillow**

cushion for a sleeper's head or any object used for that purpose

**3.13****quilt**

bedcover of two thicknesses with padding sewn into compartments

**3.14****underlay**

textile layer between the mattress and the lower sheet

## 4 Principle

A test specimen placed on a testing substrate is subjected to a smouldering cigarette placed on top of and/or below the test specimen. Any progressive smouldering and/or flaming is noted.

Where the actual mattress used is known, it can replace the testing substrate.

## 5 Criteria of ignition

### 5.1 Progressive smouldering ignition

All the types of behaviour given in a) to d) are considered to be progressive smouldering ignition:

- a) any test specimen that displays escalating combustion behaviour, making it unsafe to continue the test, and that requires forcible extinction;
- b) any test specimen that smoulders until it is essentially consumed, after a period of 1 h following the application of the smouldering cigarette;
- c) any test specimen that produces externally detectable amounts of smoke, heat or glowing, after a period of 1 h following the application of the smouldering cigarette;
- d) any test specimen that, on final examination (see Clause 12), shows evidence of active smouldering.

**NOTE** In practice, it has been found that there is usually a clear distinction between materials which can char under the influence of the smouldering cigarette, but which do not propagate further (non-progressive), and those where smouldering develops and spreads (progressive).

### 5.2 Flaming ignition

The following behaviour is considered to be flaming ignition: the occurrence of any flames initiated by a smouldering cigarette.

## 6 Health and safety of operators

**WARNING** — There is a considerable risk with these tests and it is essential that suitable precautions be taken, which may include the provision of breathing apparatus and protective clothing.

In the interest of safety, the tests shall be conducted in a suitable fume cupboard or purpose-built room, so that individuals are not exposed to fumes (see 7.4).

Readily accessible suitable means of extinguishing the test specimens shall be provided. Extinction of test specimens can be difficult and care should be taken to dispose of them only when they are completely inert. It can be necessary to immerse smouldering specimens in water or place them in a sealed non-combustible enclosure. To ensure complete safety, other suitable steps can be required.

## 7 Apparatus

### 7.1 Test rig

A suitable test rig is illustrated in Figure 1. It consists of a platform of open mesh of at least 450 mm × 450 mm, supported by a solid base. The test rig shall correspond to the dimensions of the test specimen, but can be larger than the test specimen.

The size of the mesh and the angle iron dimensions in Figure 1 are not critical.

For the tests, the rig is placed within the test enclosure (see 7.4).

### 7.2 Stopwatch

A stopwatch shall be used, capable of reading to the nearest second and measuring for at least 1 h.

### 7.3 Ignition source: smouldering cigarette

An un-tipped cylindrical cigarette complying with the following requirements shall be used.

- length: (68 ± 2) mm;
- diameter: (8,0 ± 0,5) mm;
- mass: (0,95 ± 0,10) g.

The smouldering rate shall be (8 ± 2) min/40 mm, when tested as follows.

Mark the cigarette, conditioned as described in 9.1, at 10 mm and 50 mm from the end to be lit. Light it as described in 11.2 and impale it horizontally in air (air flow rate less than 0,2 m/s) on a horizontal wire spike inserted not more than 13 mm into the unlit end. Record the time taken for it to smoulder from the 10 mm mark to the 50 mm mark. The smouldering rate may be measured on two cigarettes at the same time. The distance between cigarettes and between each cigarette and any nearby surface, such as the wall or floor of the test enclosure, shall be at least 150 mm.

### 7.4 Test enclosure

A suitable room with a volume greater than 20 m<sup>3</sup>, which contains adequate oxygen for testing, or a smaller enclosure with a through-flow of air equipped with inlet and extraction systems shall be used. Air flow rates shall not exceed 0,2 m/s in the locality of the test specimen position. This limit provides adequate oxygen without disturbing the burning behaviour.

### 7.5 Testing substrate

The testing substrate, which is used to simulate the mattress, over which the bedding items are tested, shall be a mineral-wool fibre pad having a thermal conductivity of 0,04 W/m·K.

The testing substrate shall correspond to the size of the test rig ( $\pm 10$  mm) and have a thickness of  $(25 \pm 5)$  mm (see Figure 2).

Dimensions in millimetres

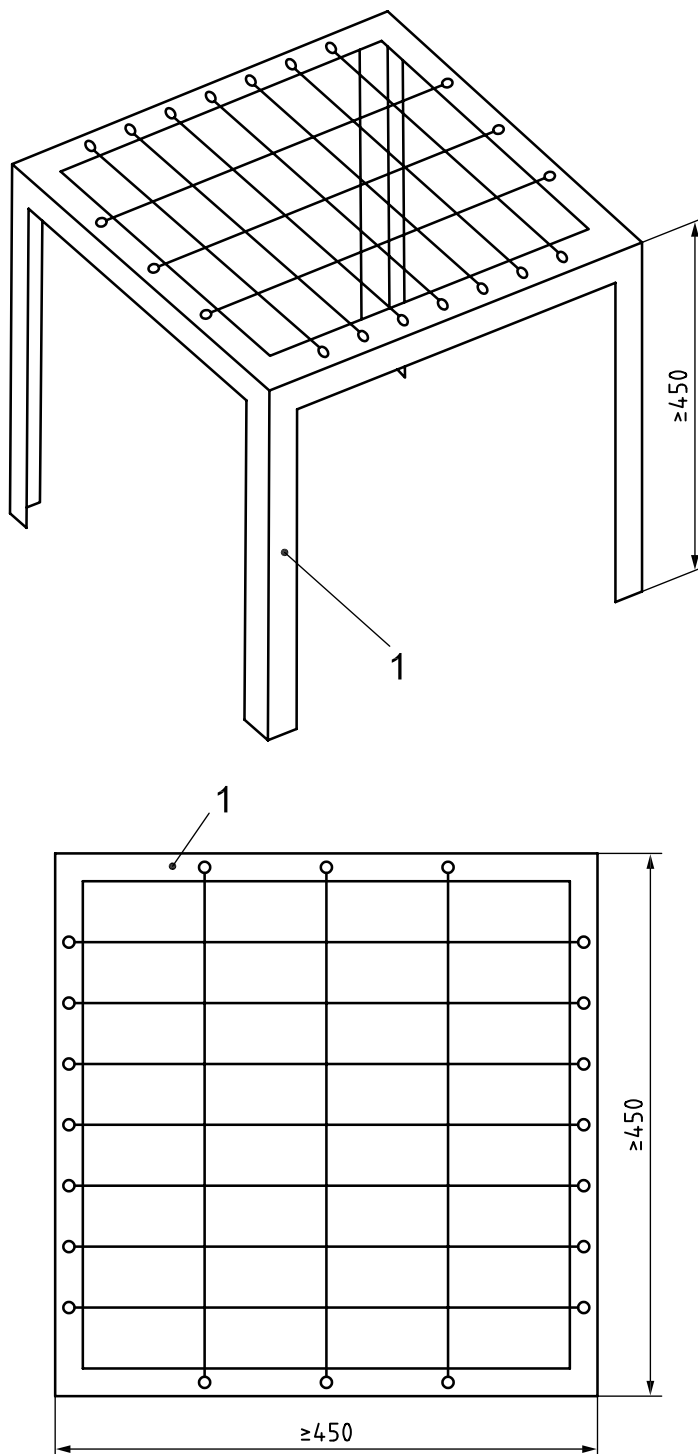

**Key**

1 angle iron

**Figure 1 — Example of a test rig**

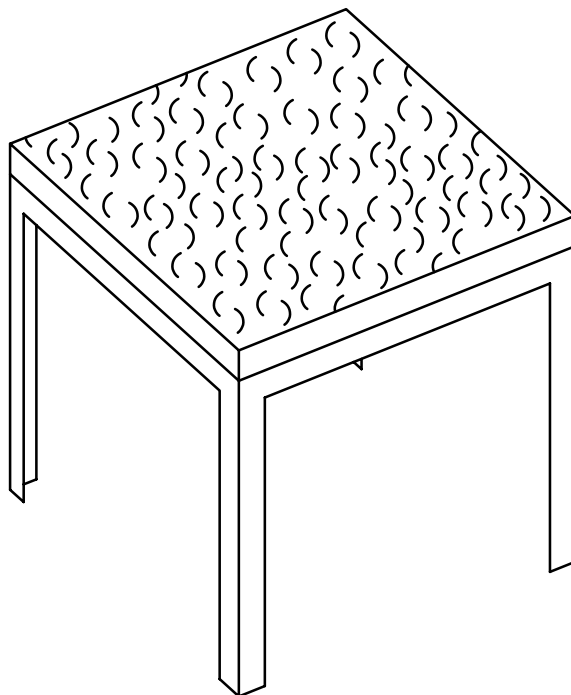

Figure 2 — Example of a test rig with testing substrate

## 8 Cleansing

The bedding items shall be washed five times using the procedure in ISO 6330 or ISO 10528, depending on their care instructions.

Materials without care instructions shall be washed five times in accordance with ISO 6330:2000, Table 1, Procedure 2A at  $(60 \pm 3)$  °C, and dried in accordance with ISO 6330:2000, 8.5, Procedure E (tumble drying at low temperatures).

Materials which are labelled “dry-clean only” shall be dry-cleaned five times in accordance with the appropriate part of ISO 3175.

Products not intended to be cleaned (single-use) shall be tested as received.

NOTE This cleansing is not intended as a life-cycle assessment of the ignitability performance of the textile product.

## 9 Atmospheres for conditioning and testing

### 9.1 Conditioning

The materials to be tested, as well as the testing substrate and the cigarettes, shall be conditioned immediately before the test for 72 h in an atmosphere having a temperature of  $(23 \pm 2)$  °C and a relative humidity of  $(50 \pm 4)$  %.

### 9.2 Testing

For testing, a draught-free environment having a temperature of 10 °C to 30 °C and a relative humidity of 15 % to 80 % shall be used. Specimens shall be tested within 10 min of removing them from the conditioning atmosphere.

Test specimens shall be tested after cleansing, as described in Clause 8.

## 10 Test specimens

The test specimens shall be representative of the components and make-up of the finished item. The style and design of bedding items can have a significant effect on the risk of ignition.

A risk assessment should be undertaken as part of the design, taking into account factors such as piped or tape-edged finishes (where the finish can support a cigarette), trims, embroideries, embellishments, labels, fasteners, etc. Where the test specimen has such features, additional cigarettes shall be placed in these positions.

Flat materials that will not normally be folded in use (e.g. mattress covers) shall either be tested using the full sample size and a larger test rig, or may be cut to  $(450 \pm 10)$  mm  $\times$   $(450 \pm 10)$  mm.

Flat materials that will normally be folded in use (e.g. sheets, blankets) shall either be tested using the full sample size and a larger test rig, or may be cut to  $(450 \pm 10)$  mm  $\times$   $(1\ 350 \pm 10)$  mm to allow for folding three times lengthwise.

Bolsters and pillows may be cut to a maximum length of 450 mm.

Quilts and duvets may be cut to  $(450 \pm 10)$  mm  $\times$   $(450 \pm 10)$  mm (cut edges should be sealed if necessary). The test specimens shall include two original edges.

## 11 Test procedures

### 11.1 Preparation

Ensure that means of extinguishing are close at hand (see Clause 6).

Place the testing substrate on the test rig (see Figure 2) and carry out the test within 10 min of removal of the test specimen from the conditioning atmosphere (see 9.1).

Place the test specimen on the testing substrate.

It is known that a minor variation in the assembly of the test specimen, for example the tightness of bedding folds, can exert a major influence on the test results.

Details of the construction of the bedding assembly are required in the test report (see Clause 13).

### 11.2 Smouldering cigarette test

Light a cigarette and draw air through it until the tip glows brightly. Not less than 5 mm and not more than 8 mm of the cigarette shall be consumed in this operation.

Place the cigarettes in the positions specified in 11.3. For repeat tests, cigarettes may be placed in these specified positions, with each cigarette being not less than 100 mm from the nearest part of the other cigarette.

Start the stopwatch when the last cigarette is in position.

Observe the specimen for any evidence of progressive smouldering ignition or flaming ignition (see Clause 5).

**NOTE** The detection of smouldering can be difficult; it is easier to detect smoke emerging at points at a distance from the cigarette. Smoke is most easily viewed by looking down a rising column by means of a mirror.

If progressive smouldering or flaming ignition of the test specimen is observed, extinguish the test specimen, note the time the test was stopped and the reason, record that ignition occurred and discontinue testing.

If a cigarette fails to smoulder along its complete length, record that ignition has not occurred.

### 11.3 Set-up of test specimens and positions of cigarettes

#### 11.3.1 Flat bedding items that will not be folded in use

Place the test specimen flat on the test rig with the testing substrate. Two lit cigarettes shall be placed on it, one in the length direction and one in the width direction. The positions of the cigarettes shall be at least 100 mm away from the edges of the specimen and at least 100 mm away from each other.

#### 11.3.2 Flat bedding items that will normally be folded in use (e.g. sheets or blankets)

Fold the test specimen in such a way that three layers of 450 mm in length are formed. Place the test specimen on the test rig on the top of the testing substrate and lift the top layer. Place two lit cigarettes, one in the length direction and one in the width direction, between the top and second layer. Replace the top layer. Place two cigarettes, one in the length direction and one in the width direction, on top of the top layer of the test specimen. See Figure 3. The positions of the cigarettes shall be at least 100 mm away from the edges of the specimen and at least 100 mm away from each other.

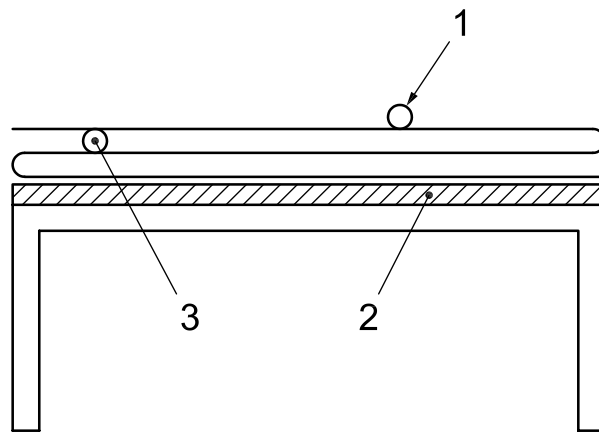

**Key**

- 1 cigarette placed on top surface
- 2 testing substrate
- 3 cigarette placed between top surface and second fold

**Figure 3 — Flat bedding items (folded in use): position of cigarettes**

#### 11.3.3 Quilts

Place the test specimen flat on the test rig with the testing substrate. Place six lit cigarettes in such a way that two will be on top of the flat part of the quilt, two will be on a line of stitching and two will be beneath the thickest part of the quilt (see Figure 4). The positions of the cigarettes shall be at least 100 mm away from the edges of the specimen and at least 100 mm away from each other. If necessary, an additional test specimen shall be used.

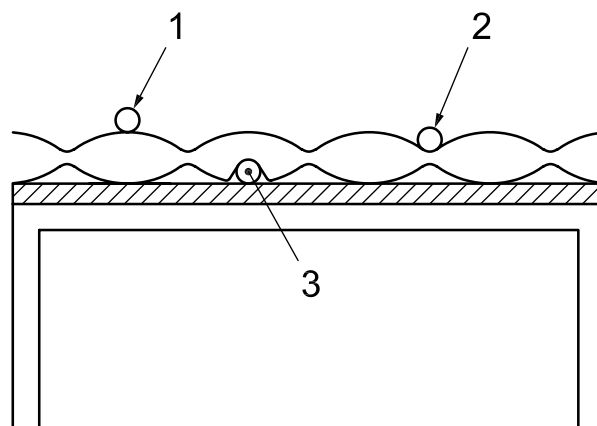
**Key**

- 1 cigarette placed horizontally on flat upper surface
- 2 cigarette placed on line of stitching
- 3 cigarette placed beneath the thickest part

**Figure 4 — Quilts: position of cigarettes**

### 11.3.4 Pillows/bolsters

Place the test specimen flat on the test rig with the testing substrate. Place four lit cigarettes in such a way that two will be on the flat upper surface of the specimen and two at the junction of the specimen with the testing substrate (see Figure 5). The positions of the cigarettes shall be at least 100 mm away from the edges of the specimen and at least 100 mm away from each other.

Where the item contains quilting, two additional cigarettes shall be placed on the seam, as specified in Figure 4.

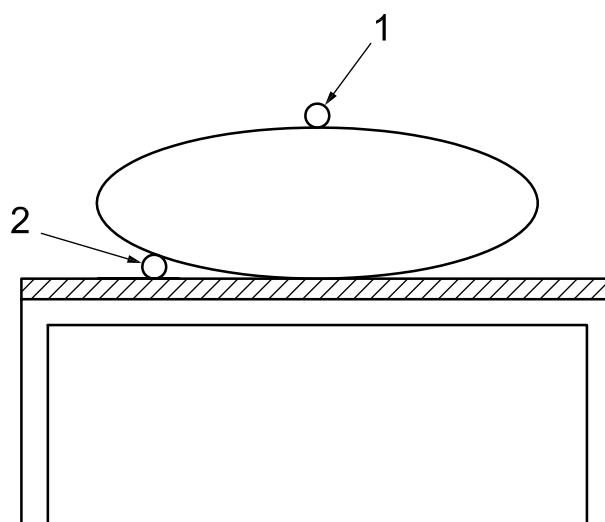
**Key**

- 1 cigarette placed horizontally on flat upper surface
- 2 cigarette placed at the junction between the testing substrate and the specimen

**Figure 5 — Pillows and bolsters: position of cigarettes**

### 11.3.5 Duvets

The test specimen shall be tested like a pillow.

Where the item contains quilting, it shall be tested like a quilt.

## 11.4 Testing of complete composites or of combinations of bedding items

### 11.4.1 Applicability

In cases where more than one or all bedding items are known, they shall be tested together because of possible interactions of the ignitability of the individual items. The relative positions of the individual items to each other during testing shall represent, as closely as possible, the actual set-up of the composite.

### 11.4.2 Set-up of testing composite

#### 11.4.2.1 Dimensions of component test specimens making up the testing composite arrangement

Test specimens shall either be cut from the components in the same way and to the same size as when testing them individually, or full-sized items shall be used. If full-sized items are used, then either the test rig shall be of an appropriate size to allow the test specimens to lie as intended on a mattress, or those parts of the test specimen which protrude beyond the edges of the test rig shall be supported in the same plane at the surface of the test rig by appropriate means.

#### 11.4.2.2 Positions of component test specimens and of cigarettes

When a pillow (or bolster) and bed covers (blanket, quilt, duvet) are placed over the bottom sheet, incontinence sheet (if applicable) and mattress cover, two lit cigarettes shall be placed on the bottom sheet at the junction of the pillow and bed covers (see Figure 6). The positions of the cigarettes shall be at least 100 mm away from the edges of the specimen and at least 100 mm away from each other.

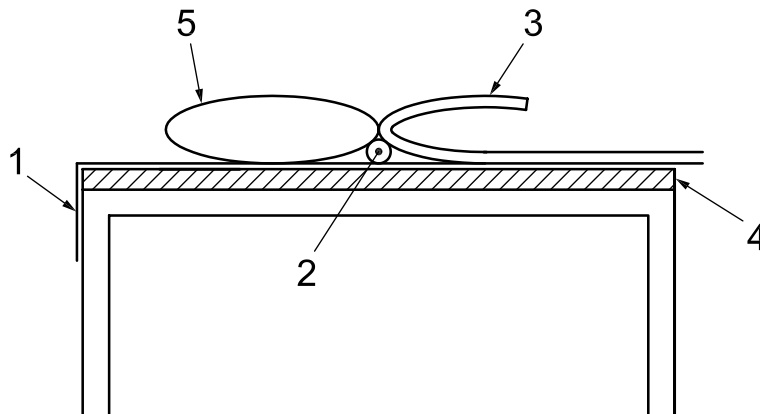

#### Key

- 1 bottom sheet
- 2 cigarette placed at junction of pillow and bed covers
- 3 bed cover (folded in half)
- 4 testing substrate
- 5 pillow

Figure 6 — Composites — Pillow and bed covers: position of cigarettes



When combinations of bedding items are tested without a pillow, two lit cigarettes shall be placed at the junction of the bottom sheet and the bed cover (see Figure 7). The positions of the cigarettes shall be at least 100 mm away from the edges of the specimen and at least 100 mm away from each other.

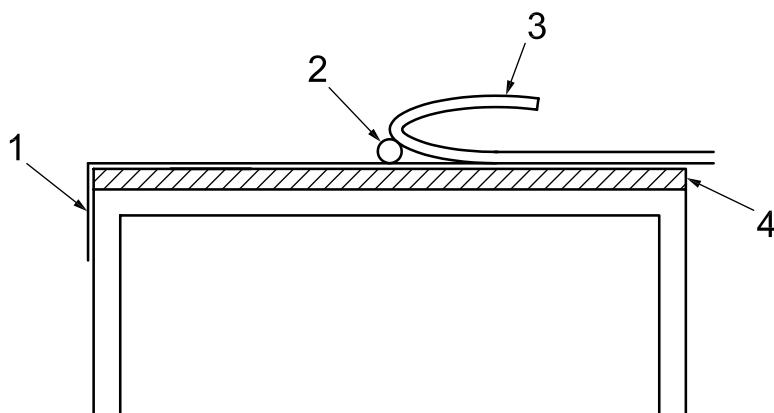

#### Key

- 1 bottom sheet
- 2 ignition source placed at junction of bottom sheet and bed cover
- 3 bed cover (folded in half)
- 4 testing substrate

**Figure 7 — Composites — Bottom sheet and bed cover: position of cigarettes**

When no pillow or bed covers are used, the combination of the bottom sheet with any underlying sheet shall be tested as in 11.3.1.

## 12 Final examination

Since progressive smouldering ignition undetected from the bedding exterior can occur, dismantle the test specimen immediately after completion of the test programme and examine it internally for smouldering ignition. If this is present, extinguish the test specimen and record that ignition has occurred. For safety reasons, ensure that all smouldering ignition has ceased before the rig is left unattended.

## 13 Test report

The test report shall include the following information:

- a) the number and date of this part of ISO 12952;
- b) the following statement: "The following test results relate only to the ignitability of the tested bedding item under the particular test conditions; they are not intended as a means of assessing the full potential fire hazard of the item in use.";
- c) the identification of the tested item and any other components of the construction of the bedding assembly;
- d) the test result:
  - ignition (I) or non-ignition (NI);
  - if ignited, the type of ignition: progressive smouldering or flaming ignition;

## ISO 12952-1:2010(E)

- e) any variation from the methods described in this part of ISO 12952;
- f) the cleansing procedure used, if required;
- g) the set-up used for the test;
- h) other features of burning, if required.



