**Petroleum and liquid petroleum products —
Calibration of horizontal cylindrical
tanks —**

Part 2:
**Internal electro-optical distance-ranging
method**

*Pétrole et produits pétroliers liquides — Jaugeage des réservoirs
cylindriques horizontaux —*

Partie 2: Méthode par mesureage électro-optique interne de la distance



Reference number
ISO 12917-2:2002(E)

© ISO 2002

PDF disclaimer

This PDF file may contain embedded typefaces. In accordance with Adobe's licensing policy, this file may be printed or viewed but shall not be edited unless the typefaces which are embedded are licensed to and installed on the computer performing the editing. In downloading this file, parties accept therein the responsibility of not infringing Adobe's licensing policy. The ISO Central Secretariat accepts no liability in this area.

Adobe is a trademark of Adobe Systems Incorporated.

Details of the software products used to create this PDF file can be found in the General Info relative to the file; the PDF-creation parameters were optimized for printing. Every care has been taken to ensure that the file is suitable for use by ISO member bodies. In the unlikely event that a problem relating to it is found, please inform the Central Secretariat at the address given below.

© ISO 2002

All rights reserved. Unless otherwise specified, no part of this publication may be reproduced or utilized in any form or by any means, electronic or mechanical, including photocopying and microfilm, without permission in writing from either ISO at the address below or ISO's member body in the country of the requester.

ISO copyright office
Case postale 56 • CH-1211 Geneva 20
Tel. + 41 22 749 01 11
Fax + 41 22 749 09 47
E-mail copyright@iso.ch
Web www.iso.ch

Printed in Switzerland

Contents

Page

Foreword	iv
1 Scope	1
2 Normative references	1
3 Terms and definitions	2
4 Precautions	2
5 Equipment	2
5.1 Electro-optical distance-ranging instrument	2
5.2 Instrument mounting	2
5.3 Laser-beam emitter	2
5.4 Stadia	3
5.5 Auxiliary equipment	3
6 General considerations	3
7 EODR instrument set up within the tank	3
8 Selection of target points	4
8.1 Introduction	4
8.2 Location of target points — General principle	5
8.3 Cylindrical courses	5
8.4 Heads	5
9 Procedure for calibration	5
10 Tolerances of reference target points	5
10.1 Distance verification	5
10.2 Verification of horizontal and vertical angles	6
11 Additional measurements	6
11.1 Reference-height determination and reference-point position	6
11.2 Data	7
11.3 Drawings	7
12 Calculation and development of capacity tables	7
Annex A (normative) Determination of the limiting angle of incidence	8
Annex B (informative) Numerical example	9

Foreword

ISO (the International Organization for Standardization) is a worldwide federation of national standards bodies (ISO member bodies). The work of preparing International Standards is normally carried out through ISO technical committees. Each member body interested in a subject for which a technical committee has been established has the right to be represented on that committee. International organizations, governmental and non-governmental, in liaison with ISO, also take part in the work. ISO collaborates closely with the International Electrotechnical Commission (IEC) on all matters of electrotechnical standardization.

International Standards are drafted in accordance with the rules given in the ISO/IEC Directives, Part 3.

The main task of technical committees is to prepare International Standards. Draft International Standards adopted by the technical committees are circulated to the member bodies for voting. Publication as an International Standard requires approval by at least 75 % of the member bodies casting a vote.

Attention is drawn to the possibility that some of the elements of this part of ISO 12917 may be the subject of patent rights. ISO shall not be held responsible for identifying any or all such patent rights.

ISO 12917-2 was prepared by Technical Committee ISO/TC 28, *Petroleum products and lubricants*, Subcommittee SC 3, *Static petroleum measurement*.

ISO 12917 consists of the following parts, under the general title *Petroleum and liquid petroleum products — Calibration of horizontal cylindrical tanks*:

- *Part 1: Manual methods*
- *Part 2: Internal electro-optical distance-ranging method*

Annex A forms a normative part of this part of ISO 12917. Annex B is for information only.

Petroleum and liquid petroleum products — Calibration of horizontal cylindrical tanks —

Part 2: Internal electro-optical distance-ranging method

1 Scope

This part of ISO 12917 specifies a method for the calibration of horizontal cylindrical tanks having diameters greater than 2 m by means of internal measurements using an electro-optical distance-ranging instrument, and for the subsequent compilation of tank-capacity tables.

This method is known as the internal electro-optical distance-ranging (EODR) method.

This part of ISO 12917 is applicable to tanks inclined by up to 10 % from the horizontal, provided a correction is applied for the measured tilt.

2 Normative references

The following normative documents contain provisions which, through reference in this text, constitute provisions of this part of ISO 12917. For dated references, subsequent amendments to, or revisions of, any of these publications do not apply. However, parties to agreements based on this part of ISO 12917 are encouraged to investigate the possibility of applying the most recent editions of the normative documents indicated below. For undated references, the latest edition of the normative document referred to applies. Members of ISO and IEC maintain registers of currently valid International Standards.

ISO 1998 (all parts), *Petroleum industry — Terminology*

ISO 7507-1:1993, *Petroleum and liquid petroleum products — Calibration of vertical cylindrical tanks — Part 1: Strapping method*

ISO 7507-4:1995, *Petroleum and liquid petroleum products — Calibration of vertical cylindrical tanks — Part 4: Internal electro-optical distance-ranging method*

ISO 12917-1:2002, *Petroleum and liquid petroleum products — Calibration of horizontal cylindrical tanks — Part 1: Manual methods*

IEC 60079-10:1995, *Electrical apparatus for explosive gas atmospheres — Part 10: Classification of hazardous areas*

IEC 60825-1:1994, *Safety of laser products — Part 1: Equipment classification, requirements and user's guide*

3 Terms and definitions

For the purposes of this part of ISO 12917, the terms and definitions given in ISO 1998, ISO 7507-1 and the following apply.

3.1

reference target point

fixed point clearly marked on the inside surface of the tank shell or a prism mounted on a tripod or stadia

3.2

slope distance

distance measured from the electro-optical distance-ranging instrument to a target point on any given course of the tank shell

3.3

target point

one of a series of points on the inside surface of the tank shell to which the slope distance, vertical angles and horizontal angles are measured by use of the electro-optical ranging instrument

4 Precautions

The general and safety precautions given in ISO 7507-1 shall apply to this part of ISO 12917. In addition, the laser beam fitted to the EODR instrument shall be operated in conformity with IEC 60825-1. The hazards, if any, in the area in which the calibration is to be carried out shall be assessed in accordance with IEC 60079-10. The equipment to be used in the calibration shall be certified as being safe for use in the area of operation.

5 Equipment

5.1 Electro-optical distance-ranging instrument

5.1.1 The angle-measuring part of the instrument shall have an angular graduation and resolution equal to or better than 0,002 gon.

This part of the instrument shall have a repeatability equal to or better than $\pm 0,005$ gon.

5.1.2 The distance-measuring part of the instrument, used for direct determination of distances, shall have a graduation and resolution equal to or better than ± 1 mm.

This part of the instrument shall have a repeatability equal to or better than ± 2 mm.

5.2 Instrument mounting

A tripod which is firm and stable. The legs of the tripod may be held firm, and steadied, by suitable devices such as magnetic bearers.

5.3 Laser-beam emitter

A low-power laser beam complying with IEC 60825-1, which is either an integral part of the EODR instrument or a separate device. If the laser beam emitter is a separate device, it may be fitted with a fibre-optic light transmitter system and a theodolite telescope eyepiece connection, by which the laser beam may be transmitted through a theodolite, or such that it may be fitted to a theodolite with its axis co-incident to the axis of the theodolite.

NOTE The laser-beam emitter is used to position target points on the tank shell.

5.4 Stadia

A rigid bar, usually 2 m long, such that the graduated length between the two stadia marks remains constant to within $\pm 0,02$ mm.

5.5 Auxiliary equipment

Auxiliary equipment includes

- a) magnets or other equipment to steady the unit, and
- b) lighting within the tank, if required.

6 General considerations

6.1 The EODR instrument shall be maintained so that the values of their measurement specifications do not exceed the values given in this part of ISO 12917.

6.2 Tanks shall only be calibrated after they have been filled at least once with a liquid of density equal to or greater than that of the liquid which they will hold when in use, and at a pressure greater than the pressure at which they will operate when in service.

NOTE The hydrostatic or pressure test applied to new tanks will satisfy this requirement in most cases.

6.3 Calibration shall be carried out without interruption.

6.4 The EODR instrument shall be verified prior to calibration.

The accuracy of the distance-measuring unit as well as the angle-measuring unit shall be verified using the procedures recommended by the manufacturer (e.g. a stadia or reference laser may be used for distance measurement).

The procedures given in ISO 7507-4:1995, annex A should be used for the verification of field equipment.

6.5 The tank shall be free from vibration and airborne dust particles.

NOTE The floor of the tank should be as free as possible from debris, dust and loose scale.

6.6 Lighting, when required, shall be placed within the tank so as not to interfere with the operation of the EODR instrument.

7 EODR instrument set up within the tank

7.1 The number and locations of the instrument stations shall be determined in order not to exceed incidence-angle limitations of equipment (see normative annex A). A typical minimum angle may be 10 gon.

If more than one station is necessary, survey traverse techniques should be used to move from one station to the other and the procedure in this subclause repeated.

7.2 The instrument shall be set up with care, particularly in the horizontal and vertical axes and according to the procedure and instructions given by the manufacturer.

7.3 The instrument shall be set up so as to be stable and free from external vibrations.

If necessary, the tank shell, in the vicinity of the instrument, shall be made firm and steady by placing heavy weights in the area.

The legs of the tripod on which the instrument is mounted may be steadied using suitable devices, such as magnetic bearers, to prevent slippage on the tank bottom.

7.4 The sighting lines from the instrument to the tank shell shall not be obstructed.

7.5 The instrument shall be switched on and brought to operating temperature for at least the minimum time recommended by the manufacturer.

7.6 If the distance-measurement part is separate, parallax adjustment is made at the start. The distance optical beam and laser beams are adjusted after temperature equilibrium, to ensure zero parallax, and then locked in position.

7.7 Select one or two reference target points.

The reference target points should be approximately 100 gon apart and preferably on the same horizontal plane as the instrument.

8 Selection of target points

8.1 Introduction

A horizontal cylinder may be considered, in mathematical terms, as an assembly of surfaces of varying curvature. The curvature of the surfaces varies with the type of tank, for example:

- horizontal cylindrical course;
- knuckle-dished end;
- flat end;
- elliptical/spherical head;
- conical.

A typical horizontal tank is shown in Figure 1.

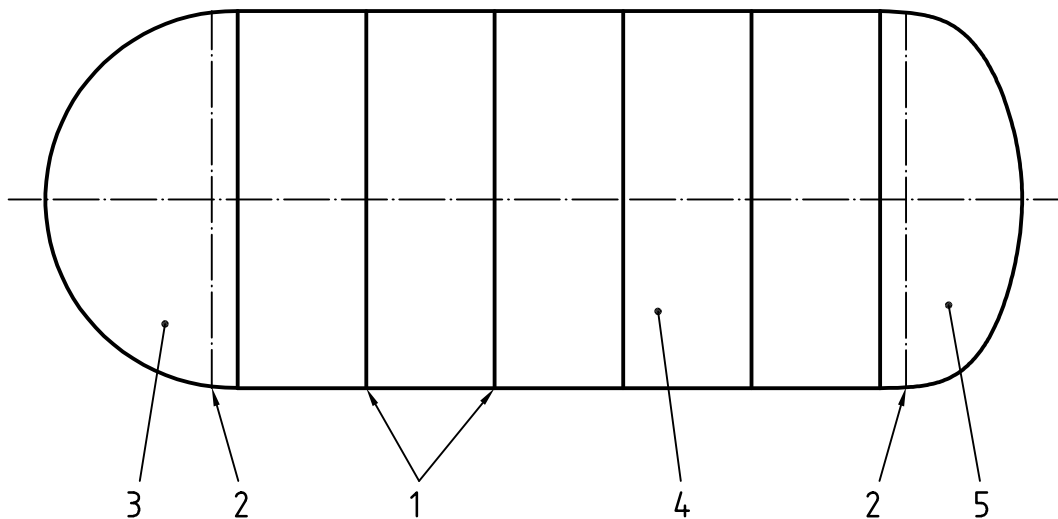

Key

- 1 Welding lines
- 2 Tangent line
- 3 Hemispherical head
- 4 Cylindrical courses
- 5 Torispherical head

Figure 1 — Typical horizontal tank

8.2 Location of target points — General principle

Target points shall be located on each surface, randomly but distributed over the entire surface. No target points shall be positioned within 300 mm of a welded seam or stiffener.

NOTE It is not a requirement of this method that any particular point be used as a target point

8.3 Cylindrical courses

A minimum of 16 target points per course in tanks of diameter less than 3 m, and a minimum of 24 target points per course in tanks of diameter 3 m or greater, shall be sighted. The uncertainty of calibration will be reduced if the number of target points is greater than the minimum specified.

8.4 Heads

8.4.1 Flat end, elliptical, spherical head, conical head

A minimum of 50 target points, randomly but evenly distributed over the surface, shall be sighted. The uncertainty of the calibration will be reduced if a greater number of target points is used.

8.4.2 Knuckle-dished end (head)

A minimum of 16 target points, randomly but evenly distributed over the surface, shall be sighted. The uncertainty of the calibration will be reduced if a greater number of target points is used.

9 Procedure for calibration

9.1 Measure and record the horizontal angle, the vertical angle and the slope distance to each reference target point. Two successive readings, at each point, shall be taken and they shall agree within the tolerance given in clause 10. Compute and record the average angles and distance to each point.

9.2 Measure the horizontal and vertical angles and the slope distance to each target point on a surface. See Figure 2.

9.3 If more than one measurement station is required, move the instrument from station to station, taking sufficient measurements at each station to ensure a proper traverse.

9.4 After all measurements from one measurement station are completed, repeat the measurements to the reference target points.

9.5 If the repeated horizontal and vertical angles and slope distances to each reference target point do not agree with the measurements taken in 9.1, within the tolerances given in clause 10, determine the reasons for such disagreement, eliminate the cause and repeat the calibration procedure.

9.6 Commence measurements at one head and progress through the tank to the other head.

9.7 Carry out all measurements without interruption.

10 Tolerances of reference target points

10.1 Distance verification

From each measurement station, the slope distance to each reference target point at the beginning and end of the calibration shall be within ± 2 mm.

Dimensions in millimeters

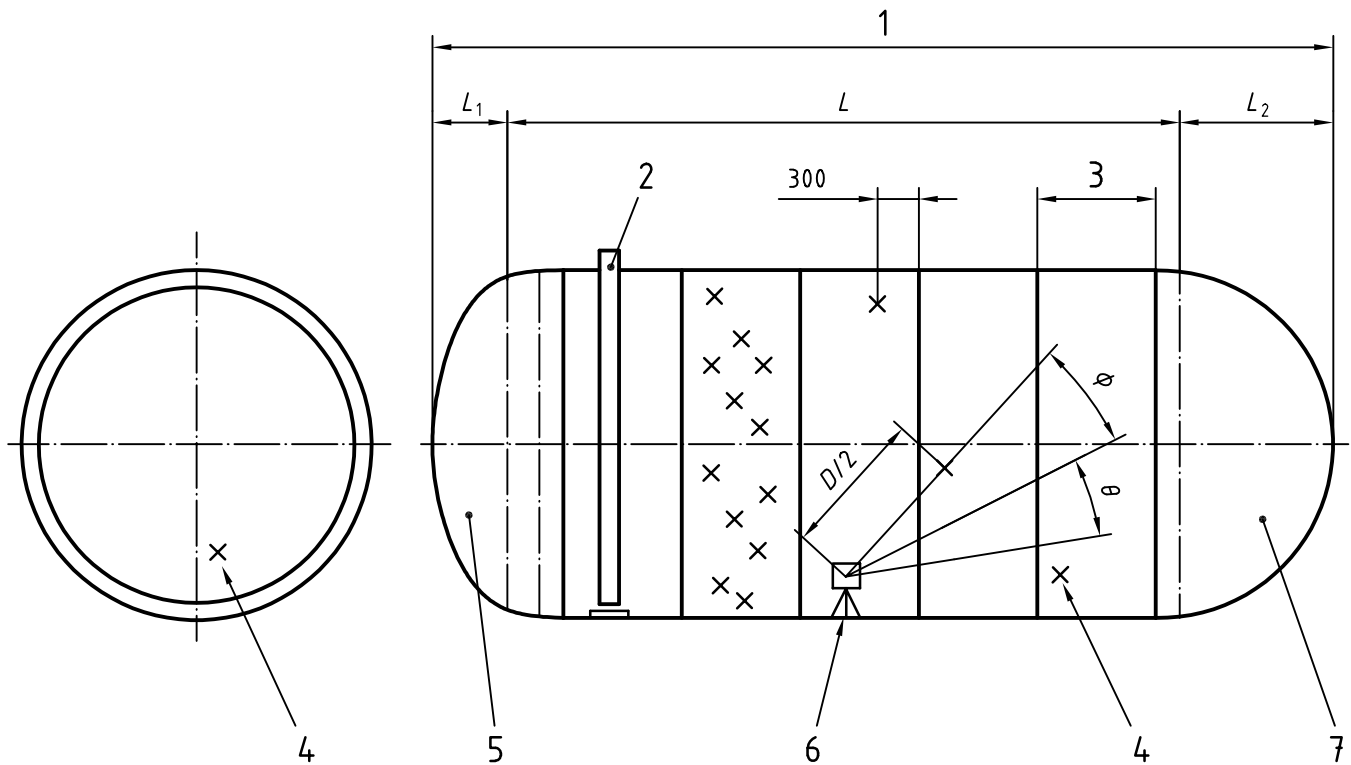

Key

- 1 Total length (inside)
- 2 Reference-gauge position
- 3 Course length
- 4 Target point
- 5 Torispherical head
- 6 Instrument
- 7 Hemispherical head
- θ Horizontal angle
- ϕ Vertical angle
- D Slope distance
- L Cylindrical length
- L_1 Length of torispherical head
- L_2 Length of hemispherical head

Figure 2 — Illustration of calibration procedure

10.2 Verification of horizontal and vertical angles

From each measurement station, the horizontal and vertical angles to each reference target point at the beginning and end of the calibration shall be within $\pm 0,010$ gon.

11 Additional measurements

11.1 Reference-height determination and reference-point position

The overall height of the reference point at each dip-hatch (upper reference point), if fitted, above the dip-point shall be measured using a dip tape and weight, as specified in ISO 7507-1. This overall height, to the nearest millimetre, shall be recorded in the calibration certificate and permanently marked on the tank adjacent to that dip-hatch.

11.2 Data

The following data shall be determined and processed:

- a) the operating temperature of the liquid to be stored in the tank;
- b) the operating pressure of the tank;
- c) safe filling height and maximum filling height;
- d) deadwood.

11.3 Drawings

If tank construction drawings are available, calibration measurements shall be compared with the corresponding dimensions shown in these drawings. Any measurements which show significant discrepancies shall be checked.

If the calibration and drawing measurements do not agree, the reasons for the discrepancy shall be determined and the calibration procedure repeated, if necessary.

12 Calculation and development of capacity tables

12.1 Compute the data which describe, in mathematical terms, each surface. Ensure that the various sets of data for each surface are coherent and describe the tank. (see ISO 7507-4:1995, annex B).

12.2 The development of the capacity table shall be carried out in accordance with ISO 12917-1. The following corrections, as described in ISO 12917-1, shall be applied in the development of the capacity tables:

- a) correction to the certified tank-shell temperature;
- b) correction to the certified tank-shell pressure;
- c) correction for deadwood;
- d) correction for slope.

Annex A (normative)

Determination of the limiting angle of incidence

- A.1 Set up a stadia of $2\text{ m} \pm 1\text{ mm}$ (this can be undertaken in the laboratory).
- A.2 The stadia may be temperature compensated to maintain a distance of 2 m automatically by external compensation or may be compensated manually.
- A.3 Mount the stadia on a floor or in a tank as indicated in Figure A.1 and level the stadia.
- A.4 Mount the tripod with EODR, as illustrated in Figure A.1.
- A.5 For a given distance, D , establish coordinates of target points A and B on the reference bar.
- A.6 Compute the distance AB from EODR instruments.
- A.7 The maximum variation between the value of AB computed in A.6 and 2 m shall be $\pm 3\text{ mm}$.
- A.8 Increase the distance D , remeasure the angles to the fixed points A and B on the stadia. Compute the distance AB using the remeasured angles. Continue this procedure until the variation between the computed value of AB and the standard length of the stadia exceeds $\pm 3\text{ mm}$. Note the smaller angle, of the two measured, and record it as the limiting angle of incidence.

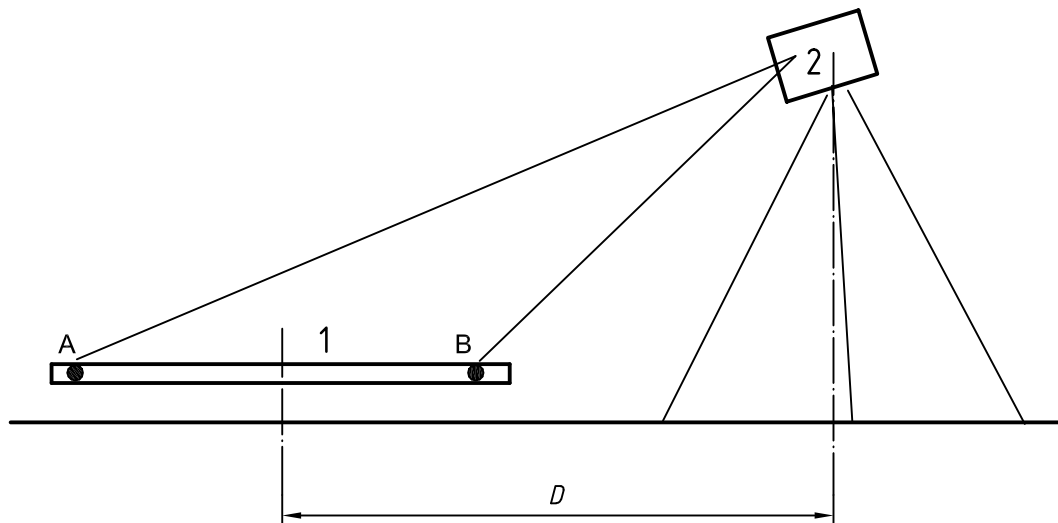

Key

- 1 Stadia
- 2 EODR

Figure A.1 — Test set up

Annex B (informative)

Numerical example

NOTE θ and ϕ are illustrated in Figure 2. D is defined in 3.2 (θ and ϕ are in gons, D is in millimetres).

B.1 Target points on the cylinder

Course numbers 1 to 9 are given in Tables B.1 to B.9.

Table B.1 — Course No. 1

Target points	θ	ϕ	D
1	196,010 5	110,262 0	11,118
2	201,895 0	106,007 0	11,373
3	203,321 5	101,245 0	11,549
4	199,962 5	93,552 0	11,377
5	194,353 5	91,295 0	11,352
6	187,331 0	93,830 0	11,423
7	184,172 0	101,000 0	11,453
8	186,851 5	107,517 0	11,365
9	195,271 5	110,960 0	10,388
10	202,547 0	106,280 0	10,530
11	204,392 0	100,850 0	10,302
12	201,520 5	93,632 0	10,333
13	194,226 5	90,380 0	10,440
14	186,282 0	93,267 0	10,331
15	183,152 0	100,342 0	10,356
16	184,921 5	106,497 0	10,363

Table B.2 — Course No. 2

Target points	θ	ϕ	D
1	195,002 0	111,587 0	9,724
2	202,440 0	107,615 0	9,758
3	204,910 5	100,405 0	9,754
4	201,035 0	92,442 0	9,890
5	196,301 5	90,095 0	9,920
6	185,071 5	93,592 0	9,740
7	182,572 5	100,207 0	9,814
8	185,352 5	108,105 0	9,760
9	193,199 5	112,950 0	8,508
10	203,889 0	107,892 0	8,688
11	206,239 0	100,180 0	8,699
12	202,354 5	91,520 0	8,703
13	194,041 5	87,712 0	8,472
14	184,221 0	92,332 0	8,700
15	181,086 0	99,220 0	8,666
16	182,046 0	106,390 0	8,439

Table B.3 — Course No. 3

Target points	θ	ϕ	D
1	193,351 5	113,705 0	7,942
2	204,112 5	109,335 0	8,026
3	207,331 5	100,890 0	8,076
4	203,935 0	91,482 0	8,011
5	194,431 5	86,827 0	8,002
6	182,230 0	92,820 0	8,002
7	179,808 5	98,662 0	7,900
8	182,829 5	109,145 0	7,851
9	193,449 0	115,725 0	6,782
10	207,259 0	108,630 0	6,828
11	209,639 0	99,165 0	6,856
12	205,942 0	89,980 0	6,843
13	194,401 5	84,000 0	6,762
14	179,568 0	92,382 0	6,840
15	177,326 5	99,012 0	6,814
16	181,362 0	110,622 0	6,776

Table B.4 — Course No. 4

Target points	θ	ϕ	D
1	192,828 5	116,792 0	6,293
2	208,300 5	109,240 0	6,334
3	210,623 0	98,077 0	6,425
4	205,500 0	87,675 0	6,416
5	194,440 0	82,960 0	6,406
6	178,963 5	90,765 0	6,358
7	175,854 0	99,290 0	6,315
8	178,279 5	108,547 0	6,312
9	192,586 0	120,827 0	5,010
10	212,160 5	111,107 0	5,045
11	215,411 5	97,767 0	5,042
12	207,221 0	82,820 0	5,118
13	193,545 5	78,045 0	5,135
14	175,354 5	88,517 0	5,208
15	171,318 5	99,640 0	5,098
16	173,769 0	109,090 0	5,108

Table B.5 — Course No. 5

Target points	θ	ϕ	D
1	192,041 0	123,362 0	4,438
2	214,493 5	111,757 0	4,541
3	217,165 5	98,845 0	4,693
4	214,871 5	88,687 0	4,663
5	193,458 5	75,457 0	4,664
6	176,063 0	82,675 0	4,652
7	168,951 0	97,505 0	4,630
8	171,354 0	109,627 0	4,613
9	192,200 0	129,992 0	3,444
10	222,179 0	113,145 0	3,474
11	225,482 0	97,632 0	3,519
12	221,152 5	82,230 0	3,540
13	193,436 5	66,610 0	3,570
14	166,536 5	80,385 0	3,564
15	160,495 5	96,290 0	3,538
16	163,738 5	113,445 0	3,447

Table B.6 — Course No. 6

Target points	θ	ϕ	D
1	193,861 5	135,665 0	2,914
2	227,810 5	116,255 0	2,907
3	231,322 5	97,847 0	3,005
4	219,733 0	72,112 0	3,123
5	193,835 0	61,947 0	3,211
6	166,483 0	70,700 0	3,103
7	155,196 0	99,190 0	3,106
8	160,048 0	115,762 0	3,078
9	191,506 0	154,790 0	2,012
10	246,433 5	120,092 0	2,094
11	252,512 5	89,502 0	2,106
12	237,006 5	54,565 0	2,203
13	193,771 5	41,232 0	2,311
14	151,061 0	58,310 0	2,336
15	133,682 0	91,362 0	2,198
16	144,662 5	133,652 0	2,064

Table B.7 — Course No. 7

Target points	θ	ϕ	D
1	242,361 0	159,810 0	1,675
2	267,218 0	121,435 0	1,724
3	269,530 0	90,347 0	1,801
4	254,902 0	47,412 0	1,940
5	190,475 0	27,155 0	2,042
6	128,496 0	54,002 0	2,004
7	119,625 5	86,880 0	1,940
8	121,601 5	121,847 0	1,843
9	338,683 5	159,897 0	1,592
10	307,674 0	123,877 0	1,605
11	311,701 0	89,462 0	1,742
12	316,502 5	54,352 0	1,842
13	5,369 5	15,542 0	1,954
14	71,005 0	51,020 0	1,940
15	77,312 0	89,960 0	1,847
16	73,181 0	122,107 0	1,757

Table B.8 — Course No. 8

Target points	θ	ϕ	D
1	396,611 5	159,882 0	1,806
2	332,431 5	122,225 0	1,844
3	328,588 0	90,367 0	1,954
4	336,892 0	52,072 0	2,049
5	399,042 0	29,242 0	2,134
6	55,105 0	58,467 0	2,105
7	61,739 0	89,090 0	2,042
8	56,296 0	121,612 0	1,947
9	394,874 5	134,455 0	2,737
10	357,833 0	113,920 0	2,711
11	353,185 5	93,965 0	2,776
12	362,599 5	67,345 0	2,872
13	396,503 5	53,960 0	2,946
14	28,066 5	68,347 0	2,911
15	35,283 5	88,780 0	2,923
16	29,811 5	116,112 0	2,816

Table B.9 — Course No. 9

Target points	θ	ϕ	D
1	394,872 0	128,472 0	3,221
2	366,098 5	113,905 0	3,222
3	360,109 5	93,652 0	3,267
4	365,204 0	76,047 0	3,317
5	2,771 0	60,240 0	3,306
6	21,629 5	71,915 0	3,373
7	29,201 5	95,825 0	3,352
8	23,255 0	114,512 0	3,277
9	395,381 5	120,805 0	4,263
10	374,734 5	110,675 0	4,383
11	369,298 5	97,842 0	4,339
12	374,196 0	80,712 0	4,453
13	394,500 0	71,117 0	4,589
14	12,045 0	77,647 0	4,542
15	20,053 0	95,395 0	4,416
16	13,752 0	111,467 0	4,453

B.2 Target points on the first torispherical head

Tables B.10 and B.11 give values for the spherical portion and torical junction, respectively.

Table B.10 — Spherical portion (first torispherical head)

Target points	θ	ϕ	D
1	194,340 0	93,522 0	11,986
2	194,292 0	97,350 0	12,125
3	194,292 0	100,412 0	12,156
4	194,649 5	104,507 0	12,112
5	195,353 5	107,890 0	11,976
6	197,256 0	100,362 0	12,130
7	200,704 0	100,362 0	11,993
8	189,961 5	100,402 0	12,122
9	185,887 0	100,402 0	11,952
10	187,211 5	105,522 0	11,943
11	199,689 5	105,522 0	11,954
12	199,689 5	95,707 0	11,953
13	187,641 0	95,707 0	11,950
14	190,250 0	97,490 0	12,085
15	197,803 0	97,450 0	12,075
16	197,461 5	104,287 0	12,067
17	189,756 0	104,287 0	12,068

Table B.11 — Torical junction (first torispherical head)

Target points	θ	ϕ	D
1	194,889 0	109,590 0	11,835
2	201,386 5	105,450 0	11,829
3	202,442 5	100,982 0	11,862
4	200,282 5	95,085 0	11,872
5	194,215 0	92,100 0	11,860
6	188,083 5	94,410 0	11,886
7	185,076 0	100,215 0	11,858
8	186,002 5	105,200 0	11,828

B.3 Target points on the second torispherical head

Tables B.12 and B.13 give values for the spherical portion and torical junction, respectively.

Table B.12 — Spherical portion (second torispherical head)

Target points	θ	ϕ	D
1	394,802 0	113,782 0	4,901
2	394,361 5	103,330 0	5,000
3	394,361 5	96,377 0	5,017
4	394,362 0	87,402 0	5,015
5	394,361 5	77,460 0	4,990
6	376,668 0	96,770 0	4,939
7	385,471 5	96,487 0	5,005
8	3,620 0	96,572 0	5,000
9	12,029 0	96,887 0	4,956
10	7,386 0	107,410 0	4,926
11	7,386 0	83,757 0	4,988
12	380,381 0	83,757 0	4,969
13	380,381 5	107,557 0	4,909
14	387,851 5	101,970 0	4,994
15	2,632 5	101,972 0	4,991
16	1,520 0	89,762 0	5,014
17	387,739 5	89,562 0	5,012

Table B.13 — Torical junction (second torispherical head)

Target points	θ	ϕ	D
1	394,453 5	117,260 0	4,820
2	376,245 0	108,347 0	4,804
3	372,033 5	95,727 0	4,803
4	378,122 0	80,330 0	4,857
5	393,942 5	74,785 0	4,946
6	6,910 5	78,022 0	4,928
7	16,463 5	94,855 0	4,870
8	11,913 5	109,372 0	4,829

B.4 Results

B.4.1 Cylinder

— Radius: $R = 1,699$ m

— Axis vector: $V_x = 0,995$ 2

$V_y = 0,093$ 1

\Rightarrow slope = 0,029 9

$V_z = 0,029$ 9

— Length: $L = 15,881$ m

B.4.2 First torispherical head

— Torus radius: $r_1 = 0,361$ m

— Sphere radius: $R_1 = 3,677$ m

— Head lengths: $L_1 = 0,643$ m

B.4.3 Second torispherical head

— Torus radius: $r_2 = 0,382$ m

— Sphere radius: $R_2 = 3,657$ m

— Head length: $L_2 = 0,659$ m

Total length = $L_1 + L + L_2 = 17,183$ m

© 2011 ISO

ICS 75.180.30

Price based on 14 pages

© ISO 2002 – All rights reserved