**Zinc sulfide concentrates —
Determination of zinc —
Ion-exchange/EDTA titrimetric method**

*Concentrés sulfurés de zinc — Dosage du zinc — Méthode par échange
d'ions et titrage à l'EDTA*



Reference number
ISO 12739:2006(E)

© ISO 2006

PDF disclaimer

This PDF file may contain embedded typefaces. In accordance with Adobe's licensing policy, this file may be printed or viewed but shall not be edited unless the typefaces which are embedded are licensed to and installed on the computer performing the editing. In downloading this file, parties accept therein the responsibility of not infringing Adobe's licensing policy. The ISO Central Secretariat accepts no liability in this area.

Adobe is a trademark of Adobe Systems Incorporated.

Details of the software products used to create this PDF file can be found in the General Info relative to the file; the PDF-creation parameters were optimized for printing. Every care has been taken to ensure that the file is suitable for use by ISO member bodies. In the unlikely event that a problem relating to it is found, please inform the Central Secretariat at the address given below.

© ISO 2006

All rights reserved. Unless otherwise specified, no part of this publication may be reproduced or utilized in any form or by any means, electronic or mechanical, including photocopying and microfilm, without permission in writing from either ISO at the address below or ISO's member body in the country of the requester.

ISO copyright office
Case postale 56 • CH-1211 Geneva 20
Tel. + 41 22 749 01 11
Fax + 41 22 749 09 47
E-mail copyright@iso.org
Web www.iso.org

Published in Switzerland

Contents

Page

1	Scope	1
2	Normative references	1
3	Principle	1
4	Reagents	1
5	Apparatus	3
6	Sample	3
6.1	Test sample	3
6.2	Test portion	3
7	Procedure	3
7.1	Number of determinations	3
7.2	Blank test	4
7.3	Dissolution of test portion	4
7.4	Preparation of the ion-exchange column	4
7.5	Adsorption of zinc on ion-exchange column	5
7.6	Elution of zinc from ion-exchange column	5
7.7	Titration	5
7.8	Determination of the titration factor of the EDTA standard volumetric solution	5
8	Expression of results	6
9	Precision	7
9.1	Expression of precision	7
9.2	Procedure for obtaining the final result	7
9.3	Between-laboratories precision	7
9.4	Check of trueness	8
10	Test report	9
	Annex A (normative) Ion-exchange resins and columns	10
	Annex B (normative) Procedure for the preparation and determination of the mass of a predried test portion	12
	Annex C (normative) Determination of cadmium by atomic absorption spectrometry	14
	Annex D (normative) Flowchart of the procedure for the acceptance of analytical values for test samples	16
	Annex E (informative) Effect of potentially interfering elements	17
	Annex F (informative) Derivation of precision equations	18
	Bibliography	23

Foreword

ISO (the International Organization for Standardization) is a worldwide federation of national standards bodies (ISO member bodies). The work of preparing International Standards is normally carried out through ISO technical committees. Each member body interested in a subject for which a technical committee has been established has the right to be represented on that committee. International organizations, governmental and non-governmental, in liaison with ISO, also take part in the work. ISO collaborates closely with the International Electrotechnical Commission (IEC) on all matters of electrotechnical standardization.

International Standards are drafted in accordance with the rules given in the ISO/IEC Directives, Part 2.

The main task of technical committees is to prepare International Standards. Draft International Standards adopted by the technical committees are circulated to the member bodies for voting. Publication as an International Standard requires approval by at least 75 % of the member bodies casting a vote.

Attention is drawn to the possibility that some of the elements of this document may be the subject of patent rights. ISO shall not be held responsible for identifying any or all such patent rights.

ISO 12739 was prepared by Technical Committee ISO/TC 183, *Copper, lead, zinc and nickel ores and concentrates*.

This second edition cancels and replaces the first edition (ISO 12739:1997), which has been technically revised.

Zinc sulfide concentrates — Determination of zinc — Ion-exchange/EDTA titrimetric method

WARNING — This International Standard may involve hazardous materials, operations and equipment. It is the responsibility of the user of this International Standard to establish appropriate health and safety practices and determine the applicability of regulatory limitations prior to use.

1 Scope

This International Standard specifies an ion-exchange/EDTA titrimetric method for the determination of the mass fraction of zinc in zinc concentrates. The method is applicable to zinc sulfide concentrates having a mass fraction of zinc in the range from 11 % to 62 %.

2 Normative references

The following referenced documents are indispensable for the application of this document. For dated references, only the edition cited applies. For undated references, the latest edition of the referenced document (including any amendments) applies.

ISO 385, *Laboratory glassware — Burettes*

ISO 648, *Laboratory glassware — One-mark pipettes*

ISO 1042, *Laboratory glassware — One-mark volumetric flasks*

ISO 3696, *Water for analytical laboratory use — Specification and test methods*

ISO 4787, *Laboratory glassware — Volumetric glassware — Methods for use and testing of capacity*

ISO 9599, *Copper, lead and zinc sulfide concentrates — Determination of hygroscopic moisture in the analysis sample — Gravimetric method*

3 Principle

The test portion of zinc concentrate is dissolved in hydrochloric, nitric and sulfuric acids. The acidity is adjusted to about 2 mol/l with respect to hydrochloric acid. Zinc is adsorbed on a strongly basic anion-exchange resin. Some interfering ions are removed by elution with 2 mol/l dilute hydrochloric acid. Zinc is eluted with an ammonia/ammonium chloride solution. Zinc is determined in the eluate by titration with EDTA at a pH of approximately 5,6 using xylenol-orange indicator.

4 Reagents

During the analysis, only reagents of recognized analytical grade and water that complies with grade 2 of ISO 3696 shall be used.

4.1 Zinc, 99,99 % minimum purity, free from oxide prior to use.

The surface of the metal may be cleaned by immersing the metal in hydrochloric acid (4.3) diluted 1 + 9, for 1 min, then washed well with water followed by an acetone rinse and dried in an oven at 50 °C.

4.2 Xylenol-orange indicator (0,1 % *m/m*)

Mix 0,1 g of the sodium salt of xylenol orange with 100 g of potassium nitrate crystals by gently grinding in a ceramic mortar with a pestle. Mixing is considered complete when the colour is uniform throughout.

4.3 Hydrochloric acid (ρ_{20} 1,16 g/ml to 1,19 g/ml)

4.4 Hydrochloric acid, diluted (1 + 1)

Add 500 ml of hydrochloric acid (4.3) to 500 ml of water.

4.5 Hydrochloric acid, diluted (1 + 5)

Add 100 ml of hydrochloric acid (4.3) to 500 ml of water.

4.6 Nitric acid (ρ_{20} 1,42 g/ml)

4.7 Nitric acid, diluted (1 + 1)

Add 500 ml of nitric acid (4.6) to 500 ml of water.

4.8 Sulfuric acid, diluted (1 + 1)

Add carefully and slowly, while stirring, 500 ml of sulfuric acid (ρ_{20} 1,84 g/ml) to 500 ml of water.

4.9 Sulfuric acid, diluted (1 + 100)

Add 20 ml of dilute sulfuric acid (4.8) to 1 000 ml of water.

4.10 Hydrofluoric acid (ρ_{20} 1,13 g/ml to 1,15 g/ml)

4.11 Ammonia solution, diluted (7 + 100)

Add 70 ml of aqueous ammonia solution (ρ_{20} 0,89 g/ml) to 1 000 ml of water.

4.12 Ammonia/ammonium chloride solution

Dissolve 20 g of ammonium chloride in 1 l of dilute ammonia solution (4.11).

4.13 Hydrochloric acid/ascorbic acid solution

Dissolve 0,25 g of ascorbic acid in 100 ml of dilute hydrochloric acid (4.5). Prepare fresh on the day of use.

4.14 Ammonium fluoride solution (50 g/l)

Dissolve 50 g of ammonium fluoride in water and dilute to 1 l.

4.15 Sodium thiosulfate solution (100 g/l)

Dissolve 100 g of sodium thiosulfate pentahydrate in water and dilute to 1 l.

4.16 Buffer solution (pH = 5,5)

Dissolve 250 g of ammonium acetate and 25 ml of concentrated acetic acid (ρ_{20} 1,05 g/ml) in water and dilute to 1 l.

4.17 Para-nitrophenol indicator solution (2 g/l)

Dissolve 0,2 g of para-nitrophenol in water and dilute to 100 ml.

4.18 EDTA standard volumetric solution (0,1 mol/l)

Dissolve 37,2 g of the di-sodium salt of ethylenediaminetetraacetic acid dihydrate (EDTA) in water and dilute to 1 l.

5 Apparatus

5.1 Class A volumetric glassware complying with ISO 385, ISO 648 and ISO 1042, and used in accordance with ISO 4787.

5.2 Balance, capable of being read to 0,1 mg.

5.3 Laboratory hotplate

5.4 Muffle furnace, capable of operating at 800 °C.

5.5 Platinum crucibles, of capacity 25 ml.

5.6 Ion exchange columns, having typical dimensions as shown in Annex A.

6 Sample

6.1 Test sample

Prepare an air-equilibrated test sample in accordance with ISO 9599.

NOTE A test sample is not required if predried test portions are to be used (see Annex B).

6.2 Test portion

Taking multiple increments, extract a test portion of 0,5 g, weighed to the nearest 0,1 mg, from the test sample, in such a manner that it is representative of the contents of the dish or tray. At the same time as the test portion is weighed, weigh test portions for the determination of hygroscopic moisture in accordance with ISO 9599.

Alternatively, the method specified in Annex B may be used to prepare predried test portions directly from the laboratory sample.

7 Procedure

7.1 Number of determinations

Carry out the determinations at least in duplicate, as far as possible under repeatability conditions, on each test sample.

NOTE Repeatability conditions exist where mutually independent test results are obtained with the same method on identical test material in the same laboratory, by the same operator using the same equipment, within short intervals of time.

7.2 Blank test

Determine a reagent blank. It is advisable to perform duplicate blank determinations every time an analysis is carried out on a laboratory sample. The blank samples are carried through the whole procedure, apart from where no laboratory sample test portion is required. The volume of EDTA titrant used is V_b .

7.3 Dissolution of test portion

Place the test portion in a 300 ml conical beaker. Add 25 ml of hydrochloric acid (4.3). Cover with a watch glass and heat the beaker and contents gently for 5 min.

Add 20 ml of dilute nitric acid (4.7) and 15 ml of dilute sulfuric acid (4.8). Heat and evaporate the solution to about 5 ml. Cool and add, with caution, about 50 ml of water and boil the solution.

Cool the solution to room temperature and filter it into a 300 ml beaker through a medium-speed cellulose filter paper. Wash the beaker and filter paper thoroughly with dilute sulfuric acid (4.9), collecting the washings in the same beaker.

If an acid-insoluble material is present, place the filter and insoluble residue in a platinum crucible (5.5) (see the last five paragraphs of this subclause) and gently reduce the paper to ashes in the muffle furnace (5.4) at 800 °C. Allow the crucible and residue to cool to ambient temperature. Add 2 ml of dilute sulfuric acid (4.8), 2 ml of nitric acid (4.6) and 2 ml of hydrofluoric acid (4.10) and evaporate the solution nearly to dryness. Cool and add water in small quantities to dissolve the soluble salts. Filter through a medium-speed cellulose filter paper and add the filtrate and washing solution to the initial solution obtained above as described in paragraphs 1 to 3.

Heat to evaporate the combined filtrates to a volume of 60 ml to 80 ml. Cool and add 16 ml of hydrochloric acid (4.3). Dilute to 100 ml with water.

If the sample contains lead, damage to the platinum crucible may occur. In this case, acid-insoluble material should be treated as follows.

Rinse the insoluble residues into a polytetrafluoroethylene beaker with a fine jet of water. Place the filter in a porcelain crucible and gently ash the paper in the muffle furnace at 600 °C to 700 °C. Allow the crucible to cool to ambient temperature.

Rinse the material from the crucible by washing with a small quantity of water into the polytetrafluoroethylene beaker used above. Add 2 ml of dilute sulfuric acid (4.8), 2 ml of nitric acid (4.6) and 2 ml of hydrofluoric acid (4.10), and evaporate the solution nearly to dryness.

Cool and add water in small quantities to dissolve the soluble salts. Filter through a medium-speed cellulose filter paper and add the filtrate and washing solution to the initial solution obtained above.

Should it be confirmed that the filter paper contains no zinc, the procedure of ashing the filter paper may be omitted.

7.4 Preparation of the ion-exchange column

Examples of ion-exchange columns that are suitable for use are shown in Annex A. Pack water-soaked cotton or glass-wool pads into the bottom of the column to a thickness of about 5 mm. This will retain resin in the column during use.

Soak the resin overnight in distilled water to make a slurry. With the stopcock open, carefully transfer the slurry into the column to form a settled bed. This resin bed is formed by about 16 ml of the swollen resin. Close the stopcock and put about a 5 mm thickness of water-soaked glass wool or cotton wool on top of the resin.

It is essential to ensure that the resin is covered by liquid at all times, because air trapped in a resin causes "channelling", i.e. uneven flow rate and poor efficiency in the ion exchanger. If air enters the resin bed, it is recommended that the column be emptied and then repacked.

Pass about 100 ml of hydrochloric acid (4.5) through the column ensuring that the resin is covered at all times. Adjust the flow rate to about 5 ml/min using the stopcock control. The resin can be rapidly regenerated at any time by passing 100 ml of water and then 100 ml of dilute hydrochloric acid (4.5) through the column, ensuring that the resin is always covered with liquid.

7.5 Adsorption of zinc on ion-exchange column

Quantitatively transfer the test solution obtained in 7.3 to the ion-exchange column at a flow rate of about 5 ml/min.

Rinse the beaker with small increments of dilute hydrochloric acid (4.5) and transfer the washings to the column. A total washing volume of 100 ml should be sufficient. Continue to drain the column until the liquid is 5 mm above the top wool plug.

Pass 100 ml of hydrochloric acid/ascorbic acid solution (4.13) through the column in small quantities. Then pass 100 ml of dilute hydrochloric acid (4.5) through the column. Collect the eluate in a 500 ml beaker and discard.

7.6 Elution of zinc from ion-exchange column

Elute the adsorbed zinc from the column by passing 180 ml of ammonia/ammonium chloride solution (4.12) through the resin at a flow rate of less than 5 ml/min. Collect the eluate in a 500 ml beaker.

The column should now be regenerated in preparation for the next test solution, using the procedure described in 7.4.

7.7 Titration

Add 2 to 3 drops of para-nitrophenol indicator solution (4.17) to the column eluate obtained in 7.6. Add dilute hydrochloric acid (4.4) until the colour of the solution changes from yellow to colourless.

A pH-meter may be used to adjust the pH to a value of 5,5 to 5,7 instead of using the para-nitrophenol indicator. Care should be taken to ensure that the electrodes are washed off with water before continuing the procedure.

Add successively to the solution, 20 ml of buffer solution (4.16), 3 ml of ammonium fluoride solution (4.14) and 5 ml of sodium thiosulfate solution (4.15). Add 0,5 g of xylenol-orange indicator (4.2) and swirl to dissolve. Titrate with EDTA standard volumetric solution (4.18) until the colour changes from red to yellow. Record the volume, V_t , of EDTA standard volumetric solution required.

NOTE If the test sample contains cadmium, it will be eluted with the zinc and will be titrated during the procedure in this subclause. The cadmium concentration must be determined separately and a correction made for its presence. The method for the determination of cadmium is given in Annex C. The effect of other elements commonly found in zinc concentrates is discussed in Annex E.

7.8 Determination of the titration factor of the EDTA standard volumetric solution

NOTE In order to obtain a relative accuracy of between 0,1 % and 0,2 %, it is necessary to standardize the EDTA standard volumetric solution with zinc at the same time and under the same conditions as the analysis. It is thus advisable for the calibration to follow the complete set of operating conditions set down for the analysis. Likewise, to improve the repeatability of the calibration, it is useful to prepare several zinc reference solutions.

The EDTA standard volumetric solution should be standardized as follows:

- Weigh into three separate 500 ml beakers between 0,055 g and 0,31 g of high-purity zinc metal (4.1), to the nearest 0,000 1 g, depending on the mass fraction of zinc in the test sample. Record these masses as m_1 , m_2 and m_3 .
- To each beaker, add 15 ml of dilute hydrochloric acid (4.4). Heat gently to dissolve the metal, cool and add 150 ml of ammonia/ammonium chloride solution (4.12).

- Add 2 to 3 drops of para-nitrophenol indicator solution (4.17). Add dilute hydrochloric acid (4.4) until the colour changes from yellow to colourless. Alternatively, a pH-meter may be used as indicated in the second paragraph of 7.7.
- Add successively 20 ml of buffer solution (4.16), 3 ml of ammonium fluoride solution (4.14) and 5 ml of sodium thiosulfate solution (4.15). Add 0,5 g of xylenol-orange indicator (4.2) and swirl to dissolve. Titrate each beaker with EDTA standard volumetric solution (4.18) until the colour changes from red to yellow and record the volume as V_1 , V_2 , and V_3 .
- Calculate the intermediate factor, $f_{i,x}$, for each beaker using the following formula:

$$f_{i,x} = m_x/V_x \quad \text{for } x = 1 \text{ to } 3 \quad (1)$$

where

$f_{i,x}$ is the factor obtained from the titration;

m_x is the mass of zinc weighed, in grams;

V_x is the volume of EDTA standard volumetric solution, in millilitres.

If the range of values for $f_{i,1}$, $f_{i,2}$ and $f_{i,3}$ exceeds 0,000 01 g/ml then repeat the standardization.

Otherwise, calculate the mean factor as follows:

$$f = \frac{f_{i,1} + f_{i,2} + f_{i,3}}{3} \quad (2)$$

8 Expression of results

The mass fraction of zinc in the test portion w_{zn} , expressed as a percentage, is given by the following equation:

$$w_{zn} = \left[\frac{(V_t - V_b) \times f \times 100}{m} - 0,581 w_{cd} \right] \times \frac{100}{100 - H} \quad (3)$$

where

V_t is the volume of EDTA standard volumetric solution (4.18), in millilitres, used to titrate the test solution;

V_b is the volume of EDTA standard volumetric solution (4.18), in millilitres, used to titrate the blank solution;

f is the zinc equivalence factor, in grams per millilitre, determined in 7.8;

m is the mass, in grams, of the test portion;

w_{cd} is the mass fraction of cadmium, expressed as a percentage;

H is the hygroscopic moisture content, as a percentage of the test portion (in the case of predried test portion being used $H = 0$).

Calculate the mass fraction of zinc in the test portion to the second decimal place.

9 Precision

9.1 Expression of precision

The precision of this analytical method is expressed by the following equations:

$$s_r = 0,000\ 2\bar{X} + 0,054\ 3 \quad (4)$$

$$s_L = 0,002\ 0\bar{X} + 0,052\ 4 \quad (5)$$

where

\bar{X} is the mean mass fraction of zinc, expressed as a percentage, in the sample;

s_r is the within-laboratory standard deviation, expressed as a percentage by mass;

s_L is the between-laboratories standard deviation, expressed as a percentage by mass.

See Annex F.

9.2 Procedure for obtaining the final result

See Annex D.

Calculate the following quantities from the duplicate results X_1 and X_2 (%) and process according to the flowchart in Annex F:

Mean of duplicates

$$\bar{X} = \frac{X_1 + X_2}{2} \quad (6)$$

Within-laboratory standard deviation (repeatability), as in Equation (4):

$$s_r = 0,000\ 2\bar{X} + 0,054\ 3$$

Repeatability limit

$$r = 2,8\ s_r \quad (7)$$

9.3 Between-laboratories precision

Between-laboratories precision is used to determine the agreement between the results reported by two (or more) laboratories. The assumption is that all laboratories have followed the same procedure.

Calculate the following quantities:

Mean of final results

$$\mu_{12} = \frac{\mu_1 + \mu_2}{2} \quad (8)$$

Between-laboratories standard deviation

$$s_L = 0,002\ 0\mu_{12} + 0,052\ 4 \quad (9)$$

ISO 12739:2006(E)

Within-laboratory standard deviation

$$s_r = 0,000 2\mu_{12} + 0,054 3 \quad (10)$$

Permissible tolerance

$$P = 2,8 \sqrt{s_L^2 + \frac{s_r^2}{2}} \quad (11)$$

Range

$$E = |\mu_1 - \mu_2| \quad (12)$$

where

μ_1 is the final result, as a percentage by mass of zinc, reported by laboratory 1;

μ_2 is the final result, as a percentage by mass of zinc, reported by laboratory 2.

If E is equal to or less than P , the final results are in agreement.

9.4 Check of trueness

9.4.1 General

The trueness of the analytical method can be checked by applying it to a certified reference material (CRM). When the precision has been confirmed, the final laboratory result can be compared with the certified value, A_c . There are two possibilities as follows:

$$|\mu_c - A_c| \leq C \quad (13)$$

If this condition exists, the difference between the reported result and the certified value is statistically insignificant.

$$|\mu_c - A_c| > C \quad (14)$$

If this condition exists, the difference between the reported result and the certified value is statistically significant.

where

μ_c is the final result, as a percentage of zinc mass, of the certified reference material;

A_c is the certified value, as a percentage of zinc mass, of the certified reference material;

C is a quantity, as a percentage of zinc mass, depending on the type of certified reference material used as defined in 9.4.2.

9.4.2 Type of certified reference material (CRM) or reference material (RM)

9.4.2.1 Introduction

Reference materials used for this purpose should be prepared and certified in accordance with ISO Guide 35^[1].

9.4.2.2 Reference material certified/characterized by an interlaboratory test programme

$$C = 2 \sqrt{s_L^2 + \frac{s_r^2}{n} + s^2(A_c)} \quad (15)$$

where

$s^2(A_c)$ is the variance of the certified value;

n is the number of replicate determinations.

9.4.2.3 Reference material certified/characterized by only one laboratory

$$C = 2 \sqrt{s_L^2 + \frac{s_r^2}{n}} \quad (16)$$

It is recommended that this type of certified reference material be avoided, unless the particular CRM is known to have an unbiased certified value.

10 Test report

The test report shall contain the following information:

- a) identification of the sample;
- b) a reference to this International Standard, i.e. ISO 12739;
- c) mass fraction of zinc in the sample, expressed as a percentage;
- d) date on which the test was carried out;
- e) any occurrences noticed during the determination which may have had an influence on the results.

Annex A (normative)

Ion-exchange resins and columns

A.1 Ion-exchange resins

The use of a strongly basic anion-exchange resin in the chloride form is mandatory with this method. It is also desirable that the grain size be in the range 150 μm to 300 μm and have a dry mesh size specification of 50 mesh to 100 mesh.

Such resins are manufactured by a large number of chemical companies. Some of the better-known resins are listed below.¹⁾

- Bio-Rad Analytical Grade Resin AG 1-X8;
- Mitsubishi Chemical Co. - "Diaion" S.A. 100;
- Dow Chemical Co. - "Dowex" 1-X8;
- Rohm & Haas Co. - "Amberlite" IRA 401;
- Permutit - "Zerolit" FF;
- Bayer "Lewatit" M 5080;
- Fisher "Rexyn" 111;
- Akzo Chemical Co. - "Imac" S 5-50.

A.2 Ion-exchange columns

Typical columns are shown in Figure A.1. Internal diameters are typically from 10 mm to 12 mm. Holding reservoirs (funnels) have a capacity of about 100 ml. Either cotton or glass-wool plugs are suitable at the bottom and top of the resin beds. A thickness of 5 mm is suitable for the depth of the plugs. A flow rate of 5 ml/min is essential for the determination of zinc. Some calibration of stopcock positions may be necessary to achieve a suitable flow rate before running any determinations.

1) This information is given for the convenience of users of this International Standard and does not constitute an endorsement by ISO of the products named. Equivalent products may be used if they can be shown to lead to the same results.

Dimension in millimetres

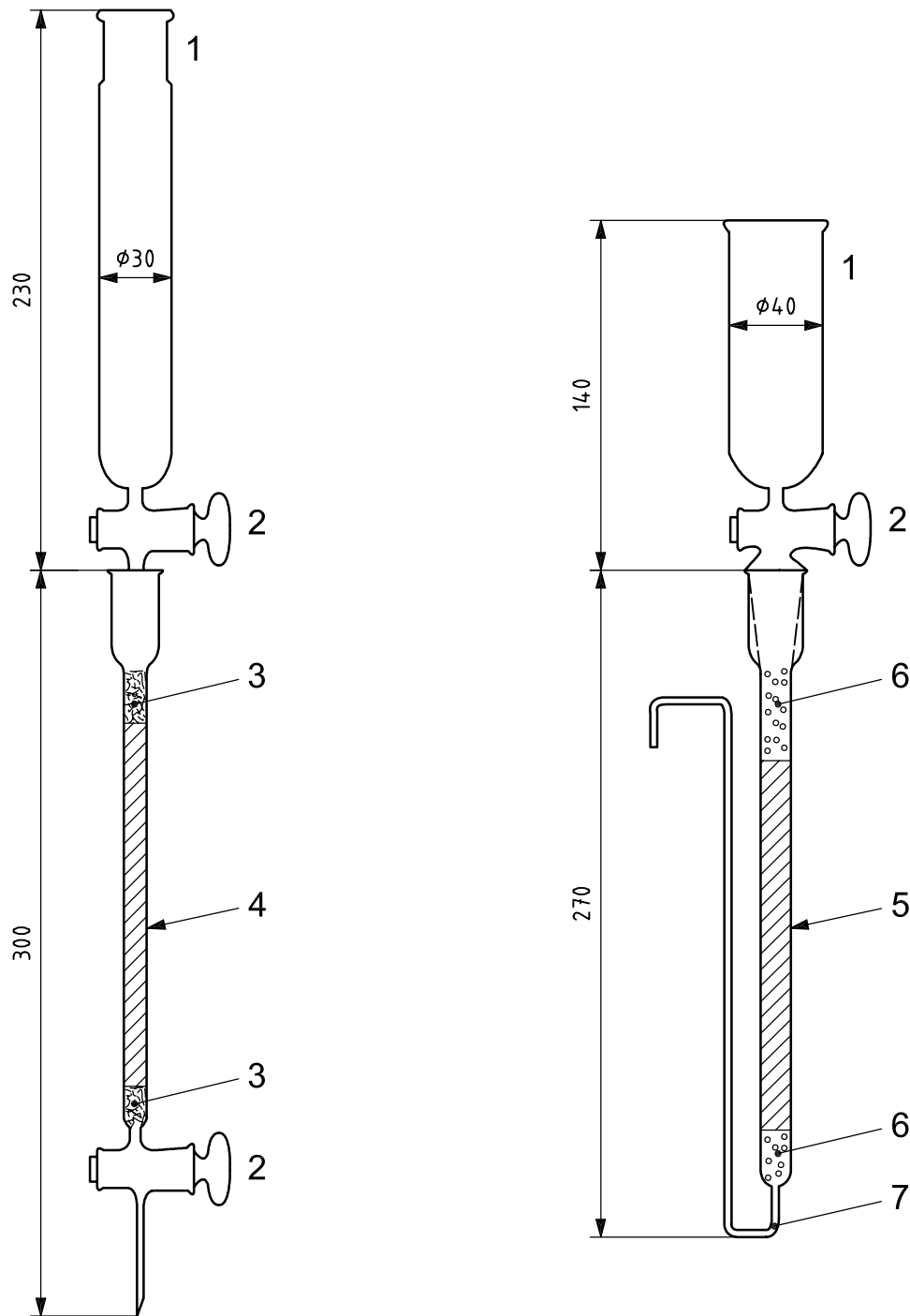

Key

- 1 dropping funnel, 100 ml
- 2 stopcock
- 3 cotton wool
- 4 chromatographic tube int. \varnothing 10
- 5 chromatographic tube int. \varnothing 12
- 6 glass wool
- 7 capillary tube int. \varnothing 2

Figure A.1 — Dimensions and types of ion-exchange column

Annex B (normative)

Procedure for the preparation and determination of the mass of a predried test portion

B.1 Scope

This method is applicable to zinc sulfide concentrates not susceptible to oxidation and having hygroscopic moisture contents ranging from 0,05 % to 2 %.

B.2 Principle

The test portion to be used for analysis is dried in air in an oven maintained at $105\text{ }^{\circ}\text{C} \pm 5\text{ }^{\circ}\text{C}$. The dried test portion is then weighed and used for the analysis. No correction for moisture is required.

B.3 Reagents

B.3.1 Desiccant, such as self-indicating silica gel or anhydrous magnesium perchlorate.

WARNING — Care should be taken when disposing of exhausted magnesium perchlorate. It must be washed down the sink with a stream of running water.

B.4 Apparatus

Ordinary laboratory equipment and the following.

B.4.1 Analytical balance, sensitive to 0,1 mg.

B.4.2 Weighing vessels, of glass, silica or corrosion-resistant metal with externally fitting airtight covers. For small test portions (less than 3 g), the mass of the vessel should be as small as possible, i.e. less than 20 g.

B.4.3 Laboratory oven, capable of maintaining a temperature of $105\text{ }^{\circ}\text{C} \pm 5\text{ }^{\circ}\text{C}$.

B.5 Procedure

B.5.1 Preparation of the weighing vessel

Dry the weighing vessel and vessel cover (B.4.2) by heating in a laboratory oven (B.4.3) at $105\text{ }^{\circ}\text{C} \pm 5\text{ }^{\circ}\text{C}$ for 1 h. Transfer the vessel and vessel cover to a desiccator containing suitable fresh desiccant (B.3.1) and allow to cool to ambient temperature.

B.5.2 Test portion

Weigh the dried weighing vessel and vessel cover (B.5.1). Immediately add a portion of the laboratory sample to provide a suitable predried test portion. An accurate total mass of the test portion and weighing vessel is not required at this point.

B.5.3 Determination of the test-portion dry mass

Transfer the uncovered weighing vessel and test portion and vessel cover to the laboratory oven (B.4.3) and dry at $105\text{ }^{\circ}\text{C} \pm 5\text{ }^{\circ}\text{C}$ for 2 h. After the 2 h period, remove the weighing vessel and dry test portion from the oven, replace the vessel cover and allow to cool to ambient temperature in the desiccator. When cool, remove the weighing vessel and dry test portion and vessel cover from the desiccator and weigh to the nearest 0,1 mg (m_4) after slightly lifting the cover and quickly replacing it. Transfer the test portion to the appropriate analytical apparatus and immediately re-weigh the empty weighing vessel plus cover. Record the mass (m_5) to the nearest 0,1 mg.

For new concentrates of unknown characteristics, it is advisable to repeat the drying for another 2 h at $105\text{ }^{\circ}\text{C} \pm 5\text{ }^{\circ}\text{C}$ and to re-weigh the weighing vessel and test portion plus vessel cover to the nearest 0,1 mg (m'_4). The mass of the test portion can be considered to be constant if the difference ($m_4 - m'_4$) is less than or equal to 0,5 mg. If this condition is not achieved, the drying and weighing steps should be repeated.

B.6 Calculation of the test-portion dry mass

The dry mass m_6 of the test portion, in grams, is given by the following equation;

$$m_6 = m_4 - m_5 \quad (\text{B.1})$$

where

m_4 is the mass, in grams, of the dried test portion plus weighing vessel and its cover;

m_5 is the mass, in grams, of the empty weighing vessel plus its cover.

The mass of dry test portion is the mass to be used to calculate the element content in the laboratory sample on a dry basis. No correction for hygroscopic moisture is required.

Annex C (normative)

Determination of cadmium by atomic absorption spectrometry

C.1 Scope

This method describes the procedure for the determination of cadmium in zinc sulfide concentrates containing cadmium in the range 0,05 % (*m/m*) to 0,20 % (*m/m*).

C.2 Principle

The sample is dissolved in hydrochloric, nitric and sulfuric acids. The mixture is evaporated to dryness and the soluble salts are taken into solution with dilute hydrochloric acid. Cadmium concentration is determined using atomic absorption spectrometry.

C.3 Reagents

C.3.1 Hydrochloric acid (ρ 1,16 g/ml to 1,19 g/ml)

C.3.2 Hydrochloric acid, diluted (1 + 1)

Add 500 ml of hydrochloric acid (C.3.1) to 500 ml of water.

C.3.3 Nitric acid (ρ 1,42 g/ml)

C.3.4 Nitric acid, diluted (1 + 1)

Add 500 ml of nitric acid (C.3.3) to 500 ml of water.

C.3.5 Sulfuric acid, diluted (1 + 1)

Add carefully and slowly, while stirring, 100 ml of sulfuric acid (ρ 1,84 g/ml) to 100 ml of water.

C.3.6 Standard stock solution of cadmium

Dissolve 0,5 g of high-purity cadmium metal in 20 ml of dilute nitric acid (C.3.4) by heating gently. Cool and transfer to a 1 000 ml volumetric flask. Make up to the mark with water. This stock solution contains 0,5 mg of cadmium per ml of solution.

C.3.7 Cadmium standard solution

Transfer, by pipette, 10 ml of cadmium stock solution (C.3.6) to a 250 ml volumetric flask. Make up to the mark with water. Prepare on the day of use. This standard solution contains 20 μ g of cadmium per ml.

C.4 Apparatus

C.4.1 Class A volumetric glassware, complying with ISO 385, ISO 648 and ISO 1042, and used in accordance with ISO 4787.

C.4.2 Balance, capable of being read to 0,1 mg.

C.4.3 Hotplate

C.4.4 Atomic absorption spectrometer

C.5 Procedure

The test portion shall be 0,5 g. Weigh the test portion to the nearest 0,1 mg and place it in a 200 ml beaker. Add 10 ml of hydrochloric acid (C.3.1) and 5 ml of nitric acid (C.3.3). Cover the beaker with a watch glass and boil gently. Cool and add 5 ml of sulfuric acid (C.3.5). Remove the watch glass and evaporate the solution to dryness.

Cool and add 10 ml of dilute hydrochloric acid (C.3.2) and 30 ml of water. Dissolve the soluble salts by heating gently. Filter through a medium-speed cellulose filter paper into a 100 ml volumetric flask. Wash the filter paper three times with about 10 ml of water. Allow to cool to ambient temperature and make up to volume with water. Determine the cadmium concentration by atomic absorption spectrometry.

C.6 Determination of cadmium by atomic absorption spectrometry

The instrumental settings used for the determination of cadmium should be according to the manufacturer's recommendations. The following instructions are issued as guidelines.

The instrument should be set up with a cadmium hollow-cathode lamp running at about 4 mA. The wavelength should be set to 228,8 with a slit width of 0,5 nm. An oxidizing acetylene/air flame is used.

The burner should be slightly rotated until a calibration solution containing 10 µg/ml of cadmium gives an absorbance reading of 0,4 absorbance units.

Three calibration solutions containing 2,00 µg, 4,00 µg and 10,00 µg of cadmium per ml should be prepared by appropriate dilution of the cadmium standard solution (C.3.7). These solutions should be used to calibrate the instrument in either the absorbance or concentration modes. The unknown solutions are then aspirated to determine the cadmium concentration of each unknown. The cadmium concentration is reported as w_{cd} , and is used to correct the zinc value in the calculation in Clause 8.

Annex D
(normative)

Flowchart of the procedure for the acceptance of analytical values for test samples

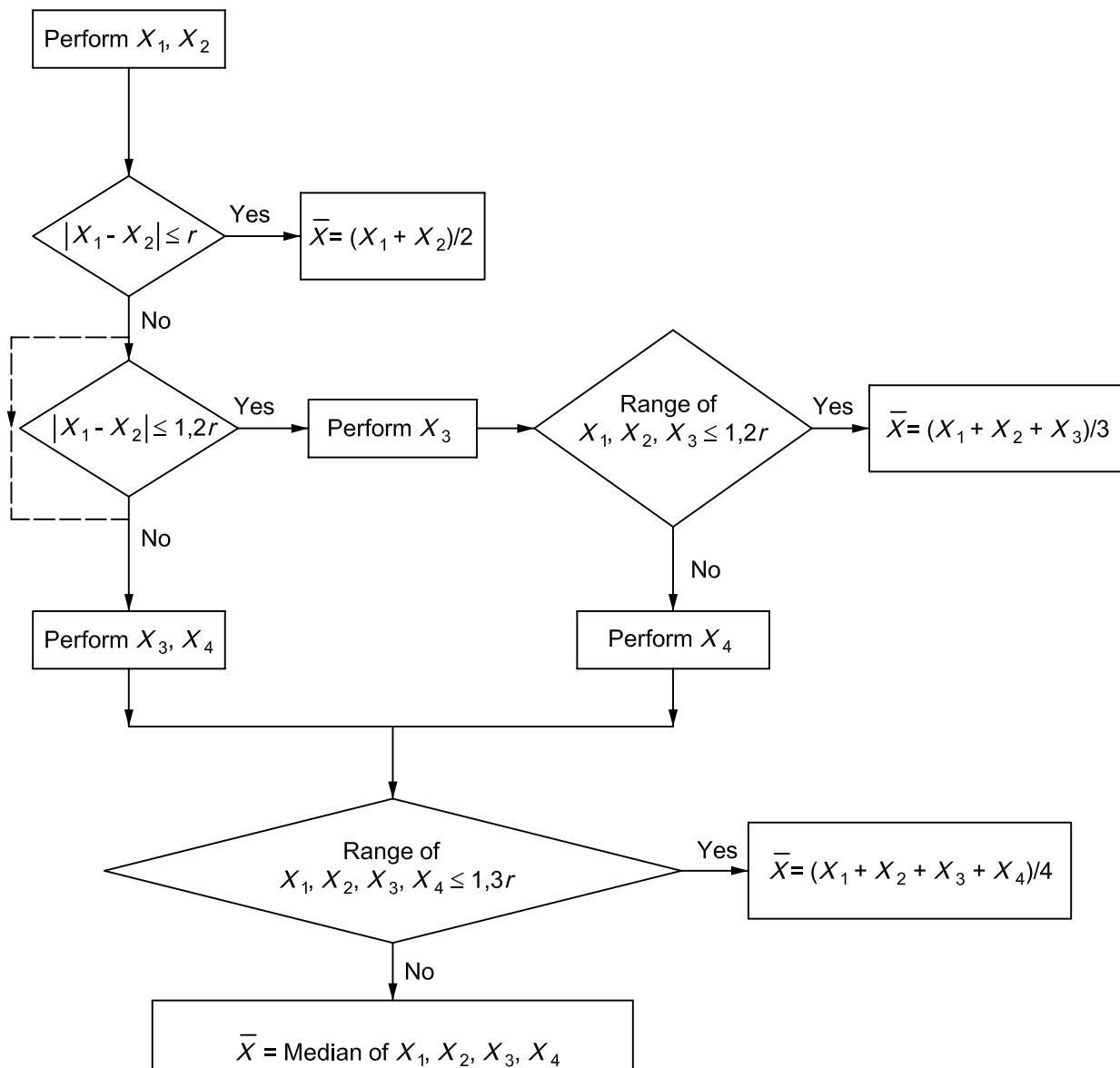

Figure D.1

r defined in 9.2

Annex E

(informative)

Effect of potentially interfering elements

E.1 Cadmium

Cadmium is eluted at the same time as zinc. It shall be determined separately and the appropriate correction shall be made to the zinc concentration.

E.2 Lead

Lead is commonly present in zinc concentrates. It is largely eliminated in the filtration step given in 7.3. Small amounts of lead remaining in the filtrate are completely separated from zinc.

E.3 Iron

There is no adsorption of Fe(II) on an ion-exchange resin in 2 mol/l dilute hydrochloric acid. Any Fe(III) present is reduced to Fe(II) by the hydrochloric acid/ascorbic acid solution.

E.4 Copper

Copper does not interfere at concentrations found in zinc concentrates.

E.5 Nickel, cobalt, manganese, calcium and aluminium

There is no absorption of these ions on the resin from a 2 mol/l dilute hydrochloric acid.

Annex F (informative)

Derivation of precision equations

F.1 Introduction

This International Standard was tested in an interlaboratory test programme involving 22 laboratories in nine countries. Five samples of zinc concentrate covering the range 11 % (m/m) to 62 % (m/m) were analysed to determine their mass fraction of zinc. The test programme was designed to determine the repeatability and within-laboratory and between-laboratories reproducibilities in general, according to ISO 5725-2^[2].

F.2 Design of the test programme

The analytical test programme was carried out with the aim of providing maximum information. Each laboratory had to use two samples (two bottles) of each concentrate and each sample was independently analysed twice.

F.3 Test samples

This test programme used five samples of zinc concentrate. The composition of these samples is shown in Table F.1.

F.4 Statistical evaluation

The procedure for statistical evaluation is illustrated schematically in Figure F.1. The results of the statistical evaluation are summarized in Tables F.2 and F.3. The precision estimates (s_r , s_L , r and P) are plotted against their corresponding sample means in Figure F.2, and the regression equations of these precisions against sample means were computed and are presented in Table F.2.

Table F.1 — Composition of zinc concentrate samples

Element	Unit	Sample number ^a				
		90-1	90-2	90-3	91-9	91-10
Zn	%(m/m)	50	33	62	11	55
S	%(m/m)	30	30	30	20	31
Fe	%(m/m)	10	14	2	8	8
Pb	%(m/m)	3	14	1	53	2
Si	%(m/m)	2	2	—	2	1
Al	%(m/m)	0,5	0,6	0,3	0,2	0,1
Cu	%(m/m)	0,2	0,5	0,1	0,8	0,1
Ca	%(m/m)	0,4	0,5	0,3	0,1	0,1
Mg	%(m/m)	0,3	0,3	0,2	0,8	0,2
Cd	%(m/m)	0,2	0,1	0,2	0,02	0,2
As	g/t	300	550	—	250	100
Sb	g/t	250	700	—	300	20
Ag	g/t	125	400	60	380	160
Co	g/t	40	90	< 1	60	20
Tl	g/t	25	60	1	—	10
Ni	g/t	2	8	2	—	8
Bi	g/t	< 1	< 1	< 1	1 600	< 1
^a 90-1 Mount Isa (Australia) 90-2 Mount Isa (Australia) 90-3 Polartis (Canada) 91-9 Cobar (Australia) 91-10 Hilton (Australia)						

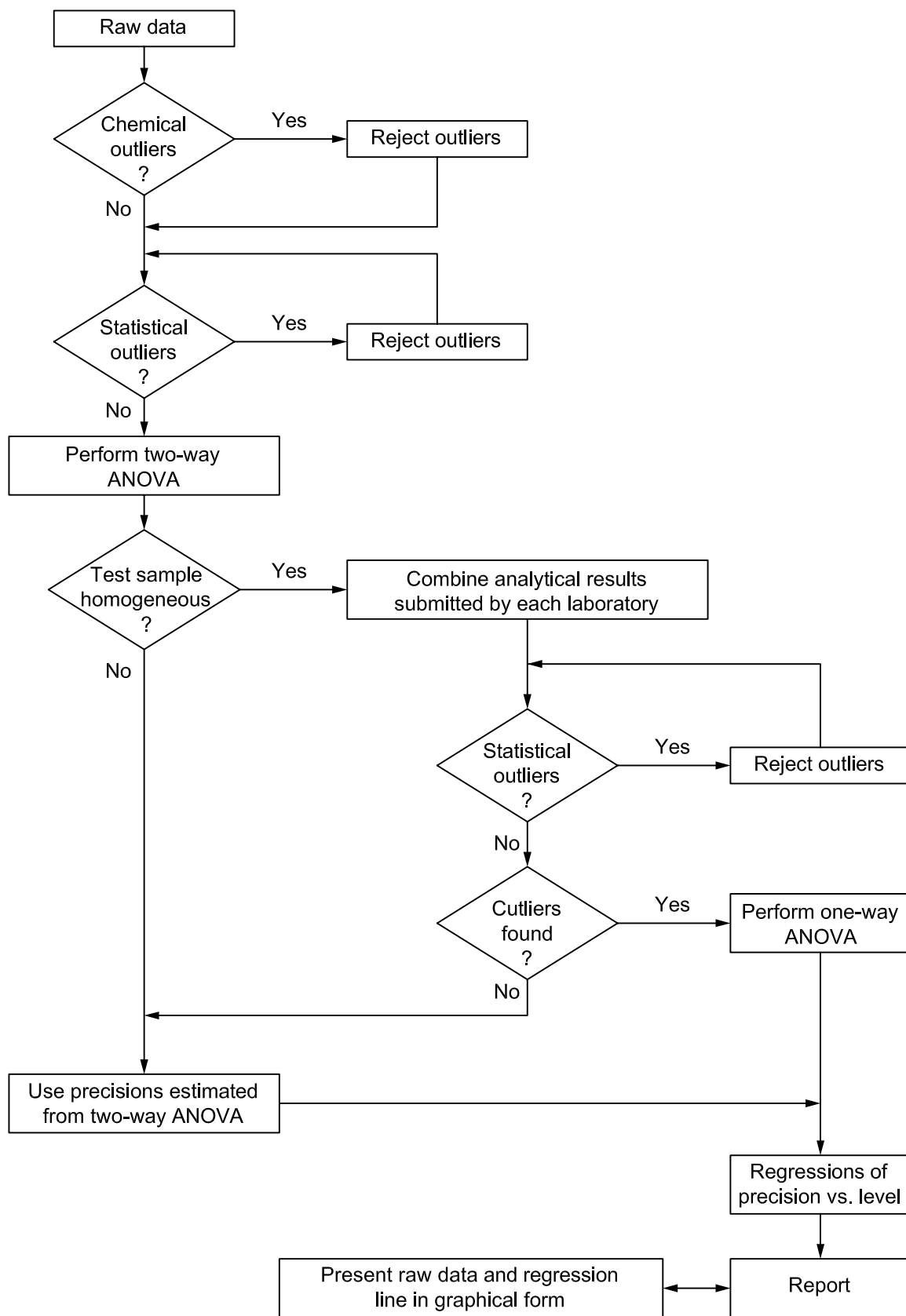

Figure F.1 — Flowchart of procedure for statistical evaluation of analytical data resulting from international tests

Table F.2 — Summary of precisions for all samples

Sample	k_o	k	n_o	n	\bar{X}	r	P	s_r	s_L	s_r/s_L
90-1	20	20	74	73	49,292	0,184	0,495	0,065	0,169	2,59
90-2	20	20	74	74	32,768	0,214	0,362	0,076	0,116	1,53
90-3	20	18	74	66	62,031	0,136	0,536	0,048	0,187	3,90
91-9	20	20	74	73	10,878	0,128	0,320	0,045	0,075	1,66
91-10	20	20	74	74	55,387	0,205	0,428	0,072	0,142	1,97

The regression equations are

$r = 0,000\ 5\bar{X} + 0,153\ 6$

$P = 0,005\ 6\bar{X} + 0,157\ 1$

$s_r = 0,000\ 2\bar{X} + 0,054\ 3$

$s_L = 0,002\ 0\bar{X} + 0,052\ 4$

Correlation coefficient

0,241 7

0,952 3

0,241 7

0,944 2

k is the number of participating laboratories used for computation of precision;

k_o is the total number of participating laboratories;

n is the number of analytical results used for computation of precision;

n_o is the total number of analytical results;

P is the permissible between-laboratories tolerance, expressed as a percentage by mass, of zinc;

r is the permissible within-laboratory tolerance (repeatability), expressed as a percentage by mass, of zinc;

s_L is the between-laboratories standard deviation, expressed as a percentage by mass, of zinc;

s_r is the within-laboratory standard deviation, expressed as a percentage by mass, of zinc;

\bar{X} is the mean mass fraction of zinc, expressed as a percentage, in the sample.

Table F.3 — List of outliers

Sample	Cochran (precision)	Grubbs (accuracy)	Lab. has only one result	Individual result (Dixon)
90-1	—	—	—	DE3
90-2	AU4, DE3	—	—	—
90-3	—	—	—	—
91-9	—	—	—	—
91-10	—	—	—	—

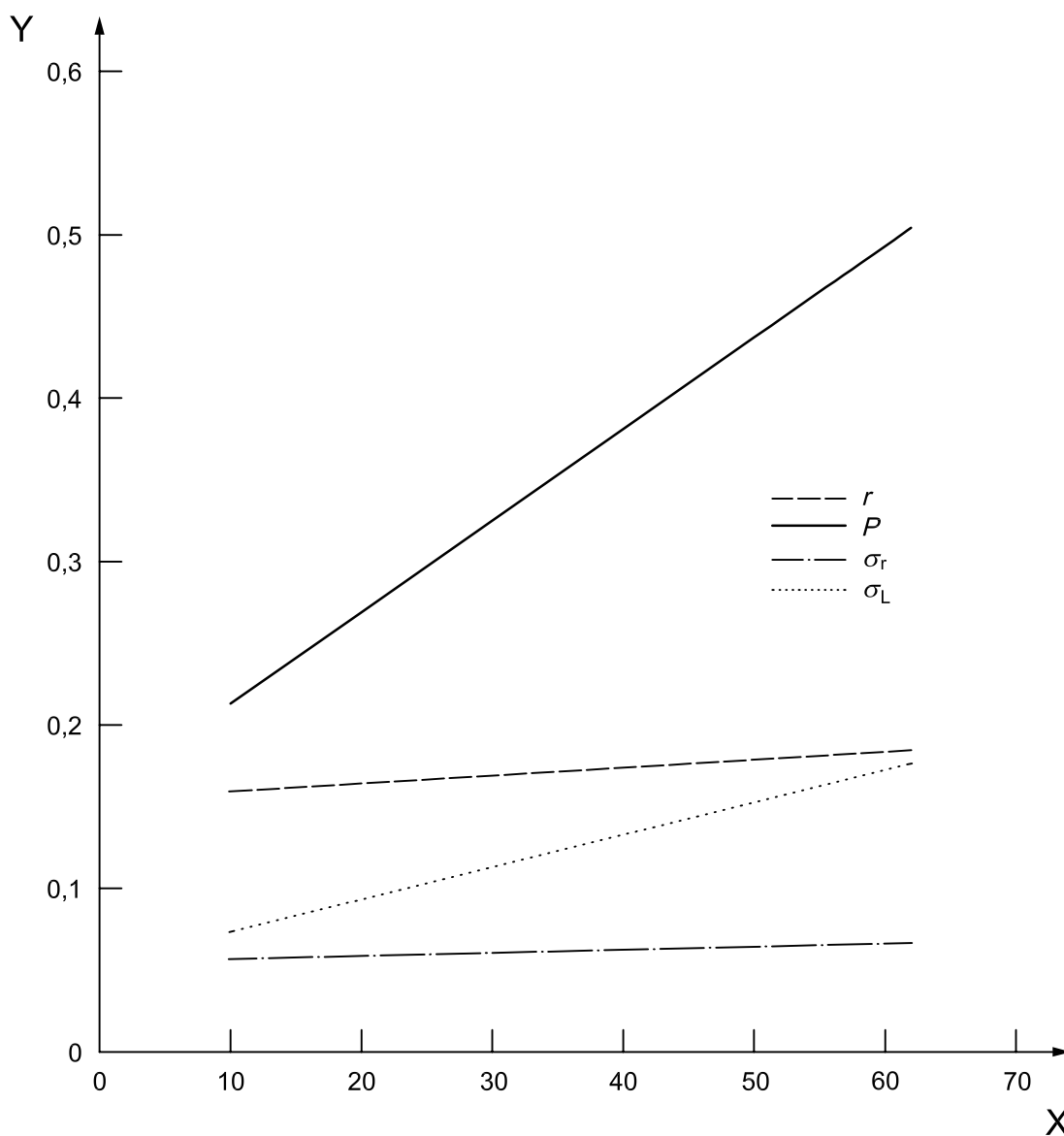

X Mean mass fraction of zinc, %

Y Precision, % (m/m) of zinc

Figure F.2 — Least-squares fit of precision against the mean mass fraction of zinc

Bibliography

- [1] ISO Guide 35:2006, *Reference materials — General and statistical principles for certification*
- [2] ISO 5725-2:1994, *Accuracy (trueness and precision) of measurement methods and results — Part 2: Basic method for the determination of repeatability and reproducibility of a standard measurement method*



ICS 73.060.99

Price based on 23 pages