**Non-destructive testing — Ultrasonic
inspection — Evaluating electronic
characteristics of ultrasonic test
instruments**

*Essais non destructifs — Contrôle aux ultrasons — Évaluation des
caractéristiques électroniques des instruments d'essai aux ultrasons*



Reference number
ISO 12710:2002(E)

© ISO 2002

PDF disclaimer

This PDF file may contain embedded typefaces. In accordance with Adobe's licensing policy, this file may be printed or viewed but shall not be edited unless the typefaces which are embedded are licensed to and installed on the computer performing the editing. In downloading this file, parties accept therein the responsibility of not infringing Adobe's licensing policy. The ISO Central Secretariat accepts no liability in this area.

Adobe is a trademark of Adobe Systems Incorporated.

Details of the software products used to create this PDF file can be found in the General Info relative to the file; the PDF-creation parameters were optimized for printing. Every care has been taken to ensure that the file is suitable for use by ISO member bodies. In the unlikely event that a problem relating to it is found, please inform the Central Secretariat at the address given below.

© ISO 2002

All rights reserved. Unless otherwise specified, no part of this publication may be reproduced or utilized in any form or by any means, electronic or mechanical, including photocopying and microfilm, without permission in writing from either ISO at the address below or ISO's member body in the country of the requester.

ISO copyright office
Case postale 56 • CH-1211 Geneva 20
Tel. + 41 22 749 01 11
Fax + 41 22 749 09 47
E-mail copyright@iso.ch
Web www.iso.ch

Printed in Switzerland

Contents

Page

Foreword	iv
Introduction	v
1 Scope	1
2 Normative reference	2
3 Terms, definitions and symbols	2
4 Abbreviations	2
5 Summary of procedure	3
6 Apparatus	3
7 Power-supply section measurements	5
8 Pulser section measurements	8
9 Receiver section measurements	12
10 Time base section measurements	16
11 Gate/alarm section measurements	18
12 Reporting format	19
Bibliography	22

Foreword

ISO (the International Organization for Standardization) is a worldwide federation of national standards bodies (ISO member bodies). The work of preparing International Standards is normally carried out through ISO technical committees. Each member body interested in a subject for which a technical committee has been established has the right to be represented on that committee. International organizations, governmental and non-governmental, in liaison with ISO, also take part in the work. ISO collaborates closely with the International Electrotechnical Commission (IEC) on all matters of electrotechnical standardization.

International Standards are drafted in accordance with the rules given in the ISO/IEC Directives, Part 3.

The main task of technical committees is to prepare International Standards. Draft International Standards adopted by the technical committees are circulated to the member bodies for voting. Publication as an International Standard requires approval by at least 75 % of the member bodies casting a vote.

Attention is drawn to the possibility that some of the elements of this International Standard may be the subject of patent rights. ISO shall not be held responsible for identifying any or all such patent rights.

ISO 12710 was prepared by Technical Committee ISO/TC 135, *Non-destructive testing*, Subcommittee SC 3, *Acoustical methods*.

Introduction

In ultrasonic non-destructive testing, pulse/echo signals are used to detect and evaluate imperfections or flaws inside a structural material. The pulse/echo ultrasonic signals are generated by various types of electronic instruments.

This International Standard describes a set of procedures for the measurement of performance characteristics in an ultrasonic test instrument that has a display screen. The procedures are used for ultrasonic test instruments operating in a nominal frequency range from 100 kHz to 25 MHz, although the procedures are also applicable to measurements on instruments utilizing higher-frequency components. The recommended techniques are designed to use commercially-available instrumentation. An ultrasonic test instrument that cannot be completely described as a combination of the electronic sections discussed in this practice can be partially evaluated. Each portion of the ultrasonic test instrument that is evaluated should fit the description for the corresponding section.

Implementation of these practices may require more detailed procedural instruction. Competence in the use of the electronic instrumentation specified is a prerequisite for effective use of these procedures. Careful selection of the specific measurements to be made is recommended. If the related parameter is not relevant to the intended application, its measurement may be unnecessary; e.g., vertical linearity may be irrelevant for an application using a single-level flaw alarm, while horizontal linearity might be required only for accurate flaw-depth or thickness measurement from the instrument display.

No minimum interval between instrument evaluations is recommended or implied. The accuracy of each measurement is dependent upon the combined accuracy of each of the electronic measuring instruments (which should be described in the specifications and calibrations for these instruments) and the precision associated with reading the values of each part of the system. It is assumed that the precision of measuring the vertical and horizontal values from the screen of the ultrasonic test instrument is ± 1 mm.

Specifically, this International Standard intends to provide techniques and procedures to achieve the following objectives:

- a) To measure performance characteristics of components of ultrasonic test instruments.
- b) To check and ensure consistent performance of such components during the life span of the instrument.
- c) To select and specify characteristics necessary for proper overall performance of the instrument.
- d) To achieve interchangeability with similar components or similar overall instruments for same type inspections.
- e) To provide a base for the correlation and comparison of performance results from different instruments and testing sources.

NOTE These procedures are not intended to preclude the use or application of ultrasonic test equipment for which some or all of the measurement techniques of this document are not applicable. Additionally, it is not intended, nor is it applicable, as a specification defining the performance of ultrasonic test systems. If such performance criteria are required, they must be agreed upon by the using parties.

Copyright International Organization for Standardization

Non-destructive testing — Ultrasonic inspection — Evaluating electronic characteristics of ultrasonic test instruments

1 Scope

1.1 This International Standard establishes the procedures for measuring performance characteristics of components of pulse-echo ultrasonic non-destructive testing instruments including both analog and digital type instruments with screen displays. The aim is to establish uniformity of evaluation techniques, to form a basis for data correlation and for interpretation of results obtained from different laboratories and at different times. Note that this International Standard establishes no acceptance criteria; such criteria should be specified by user parties.

The usual components of ultrasonic non-destructive testing instruments and the performance characteristics for which procedures for measuring these characteristics are included and listed in 1.2 to 1.6.

1.2 Power supply section:

- line regulation
- battery discharge time
- battery charge time

1.3 Pulser section:

- pulse shape
- pulse amplitude
- pulse rise time
- pulse length
- pulse frequency spectrum

1.4 Receiver section:

- vertical linearity
- frequency response
- noise and sensitivity
- dB controls

1.5 Time base section:

- horizontal linearity
- clock (pulse repetition rate)

1.6 Gate section/alarm section:

- delay and width
- resolution
- alarm level
- gain uniformity
- analog output
- back-echo gate linearity

2 Normative reference

The following normative document contains provisions which, through reference in this text, constitute provisions of this International Standard. For dated references, subsequent amendments to, or revisions of, any of these publications do not apply. However, parties to agreements based on this International Standard are encouraged to investigate the possibility of applying the most recent edition of the normative document indicated below. For undated references, the latest edition of the normative document referred to applies. Members of ISO and IEC maintain registers of currently valid International Standards.

IEC 60050-111, *International Electrotechnical Vocabulary — Chapter 111: Physics and chemistry*

3 Terms, definitions and symbols

For the purposes of this International Standard the terms, definitions and symbols listed in IEC 60050-111 as well as the following apply.

- T_m the measured rise time
- T_r the actual rise time of the instrumentation
- T_s the oscilloscope rise time

4 Abbreviations

- ASTM American Society for Testing and Materials
- DAC/EDAC distance amplitude correction/electronic distance-amplitude compensation
- EN European Norme (European Standard)
- IEC International Electrotechnical Commission
- ISO International Organization for Standardization
- JIS Japanese Industrial Standard
- PRF pulse repetition frequency
- RF radio frequency

5 Summary of procedure

5.1 Performance measurements

The electronic performance of each section is measured by identifying that portion of the electrical circuit of the instrument which comprises the section, applying the recommended stimulus or load or both, and performing the required measurements using commercially available electronic test equipment. These data are then summarized in tabular or graphical form as performance-related values which can be compared with corresponding values of other ultrasonic test instruments or of values for the same instrument obtained earlier (see clause 12 for a suggested reporting format).

5.2 Ultrasonic test Instruments and Interactions

5.2.1 Power supply section

The power supply section is that portion of the total instrument circuitry which supplies the regulated DC voltages required to power all other sections of the ultrasonic test instrument, including the high voltage (i.e pulser) circuitry.

5.2.2 Pulser section

The pulser section is that portion of the total instrument circuitry that generates the electrical pulse used to energize the search unit. The pulser section may also include the pulse-shape modification controls such as pulse length, damping or tuning controls.

5.2.3 Receiver section

The receiver section is that portion of the total instrument circuitry that amplifies, or modifies or both, the radio frequency (RF) pulses received from the search unit. This includes the RF amplifiers, detectors, video amplifiers, suppression and filtering circuits, and the cathode ray tube vertical deflection circuits. Some instruments may not contain all of these circuits.

NOTE For EDAC operation, reject or threshold, although part of the receiver section, should be turned off while making measurements unless otherwise specified by the user.

5.2.4 Time base section

The time base section provides the linear horizontal sweep or baseline. It includes the horizontal deflection circuit and the clock and delay circuits which control PRF and positioning of signals on the baseline.

5.2.5 Gate/alarm section

This section monitors the signals in the receiver section to detect the presence or absence of significant indications. The gate may include attenuator or gain controls. This section is considered separate from the receiver section for the purposes of this International Standard. The alarm signal may be audible, or a mark on voltage or current sensitive paper or some combination of these. It also may be a voltage proportional to the amplitude.

6 Apparatus

6.1 Ultrasonic test Instrument, being any electronic instrument comprised of a power supply, pulser, clock, receiver and a sweep display section to generate, receive and display electrical signals related to ultrasonic waves for examination purposes.

NOTE Some ultrasonic test instruments do not include a screen display. Some sections of this International Standard may not apply to these instruments, or may be applicable only with modifications. Such modifications should be made only by personnel competent in electronics.

6.2 Voltmeter, being any instrument capable of measuring the AC line voltage and DC battery voltage required as described in 7.1 or 7.2.

6.3 Variable transformer, such as an autotransformer or other device capable of supplying variable AC power to the ultrasonic test instrument over the full range specified by the manufacturer.

6.4 Pulser load, consisting of a 50 ohm non-inductive resistor, preferably mounted in a shielded coaxial assembly, unless otherwise requested by the using parties. The resistor shall be able to withstand the maximum peak pulser voltage. It is recommended that the complex impedance of the resistor be checked at frequencies from 100 kHz to 25 MHz in order to ensure that the magnitude is 50 ohms \pm 2 ohms, and that the phase angle is less than \pm 5°.

NOTE Other impedances may be used if specified.

6.5 Spectrum analyser, of any type (with probe assembly if required) that is capable of analysing the electrical pulse from the pulser module and displaying the frequency components of the pulse as described in 8.3. A recording of the display (photograph or chart recorder) shall be included in the report.

6.6 Oscilloscope probe, being a 100 \times or 50 \times wide band high input impedance (\geq 10 k Ω) attenuating probe to reduce the pulse amplitude, as delivered to the oscilloscope and the spectrum analyser, to a level that i) will not harm the equipment and ii) will allow for frequency and time analysis without significantly altering the pulse shape. The probe output impedance shall match the input impedance of the measurement instrument. (If the impedance is high, a terminating resistance may be required at the input to match the output impedance of the probe.) The frequency bandwidth shall be at least as wide as that of the instruments to be measured. The probe shall be able to withstand the pulser output voltage.

NOTE More than one probe may be needed to match the various test instruments used.

6.7 Function generator, capable of producing an internally or externally triggered single-cycle sine wave or five cycles of a sine wave, the frequency of which is variable over the range of the frequency capabilities of the ultrasonic test instrument to be measured. The frequency read-out shall be accurate to 1 %. Square or rectangular waves in single or burst mode shall be provided. The generator shall be capable of being triggered from a signal derived from the instrument clock to provide wave trains coherent with the display. An adjustable delay of at least 10 μ s is required.

NOTE A free running (i.e. non-triggered) single-cycle sine wave may not be used for receiver evaluation.

6.8 Electronic gate, with a variable delay and width and triggerable from either the ultrasonic test instrument pulser section output pulse or the clock section logic signal. The gate step output (i.e. the output that represents the location of the gate) shall be sufficient to trigger the function generator.

NOTE Some function generators incorporate the gate delay and width functions, in which case an electronic gate will not be needed.

6.9 Calibrated oscilloscope, capable of displaying all portions of the pulser output with sufficient time base expansion, triggering capability and frequency response to enable measurement of the pulse rise time, amplitude and length, as well as fulfilling the requirements of other measurements.

6.10 Calibrated attenuator, capable of providing a measuring range of 60 dB in 1 dB steps with an accuracy of \pm 0,5 dB and having a frequency bandwidth at least as great as the highest frequency of interest. Most attenuators have a nominal input and output impedance of 50 ohms, but other impedances may be specified. Proper termination rules shall be observed. An impedance matching probe shall be used to protect the attenuator if it is to be used to reduce pulse output.

6.11 Terminators, used to match the impedances of instruments and cables used (see 6.4); they shall be of a non-inductive, feed-through style.

6.12 Cables, coaxial, with maximum length of 2 m and a 50 ohm characteristic impedance. Other lengths and impedances may be used if authorized, but lengths shall be kept as short as possible in order to minimize the effects of cable capacitance on measurements.

6.13 Search unit, of the desired type, size and frequency required for the procedures selected for 6.15, 7.1.1, 7.2.1, 7.2.1.2, 10.2 or 10.3.

6.14 Immersion tank, (optional) consisting of an ultrasonic immersion system that will enable continuous variations of the distance between the search unit and a reflector over a water path range that will provide a time range comparable to the end use of the ultrasonic test instrument. A distance (position) scale of precision needed for the procedure described in 10.2 shall be incorporated.

6.15 Reference block, of any suitable material, containing certain features, such as flat-bottom holes, side-drilled holes, wedges, flat steps of different thickness or hemi-steps, which can be used to provide ultrasonic echo signals.

6.16 Camera or recorder, such as a screen camera or display recorder, suitable for measuring pulse characteristics, and useful in making other measurements.

7 Power-supply section measurements

7.1 AC-powered instrument line regulation

7.1.1 Connect the variable transformer (6.3), the voltmeter (6.2) and a search unit (6.13) that matches the nominal frequency of the instrument, to the ultrasonic test instrument (6.1) as shown in Figure 1. Although Figure 1 shows an immersion set-up, the evaluation may be performed by either the contact or the immersion method. The primary requirement is that the signal from the reference reflector does not vary due to coupling or position variations during the evaluation. Contact tests may require clamping of the search unit to the reference block. A block with permanently bonded search unit(s) is quite helpful.

7.1.2 Adjust the variable transformer for 100 % nominal line voltage and obtain a 50 % full-scale indication from the reference block (6.15). Decrease the variable transformer output voltage until the reference reflector indication changes its amplitude, width or horizontal position by 10 %.

NOTE Damage may result from going, in either direction, beyond the manufacturer's line voltage specification.

7.1.3 The ultrasonic test instrument display may turn off before any significant signal change is noted.

7.1.4 Increase the variable transformer output voltage(s) at which the 10 % change or turn-off occurs. The upper limit will usually be the manufacturer's specification. These are the input voltage limits.

7.2 Battery-powered instruments

7.2.1 Discharge time

7.2.1.1 With the battery in the fully-charged condition, connect a search unit (6.13) to the instrument and obtain a 50 % full-scale indication from a suitable reference block (6.15). This evaluation may be performed by either the contact or the immersion method. The primary requirement is that the signal from the reference reflector does not vary due to coupling or position changes during the battery discharge time period.

7.2.1.2 Instrument controls that affect power drain, such as PRF, display brightness, sweep range, etc., shall be set to the maximum levels corresponding to good examination practices in order to provide the maximum practical power supply loading condition.

7.2.1.3 At time intervals ≤ 15 min, record the amplitude of the signal from the reference block and plot these values versus time as shown in Figure 2 until the signal amplitude, horizontal sweep length or position changes 10 % or until the instrument display turns off. The discharge time is the time required for a change of the stated amount or until the display turns off, whichever occurs first. Record this value.

7.2.1.4 The data recording may be minimized by making an initial reading and then beginning the periodic measurements at a later time near the anticipated discharge time.

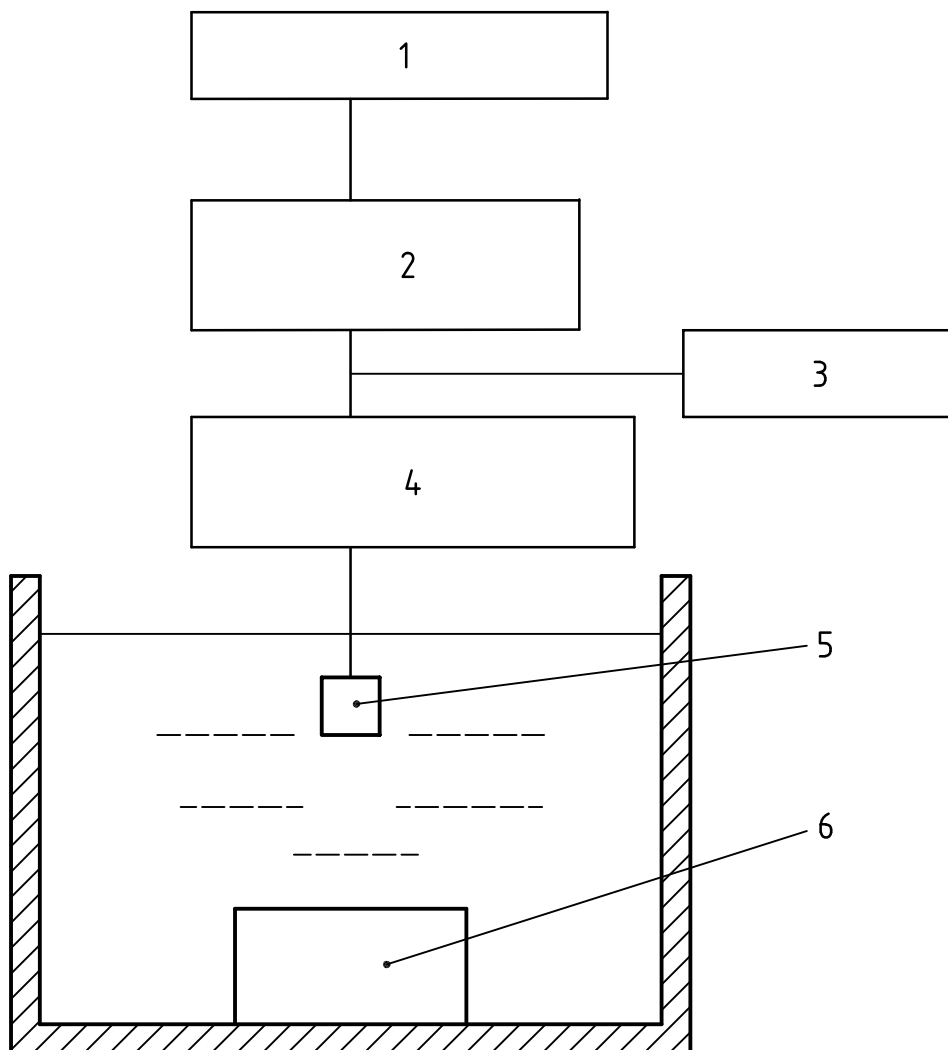

Key

- 1 Line voltage
- 2 Variable transformer
- 3 Voltmeter
- 4 Ultrasonic test instrument
- 5 Search unit
- 6 Reference block

Figure 1 — Set-up for voltage regulation measurements

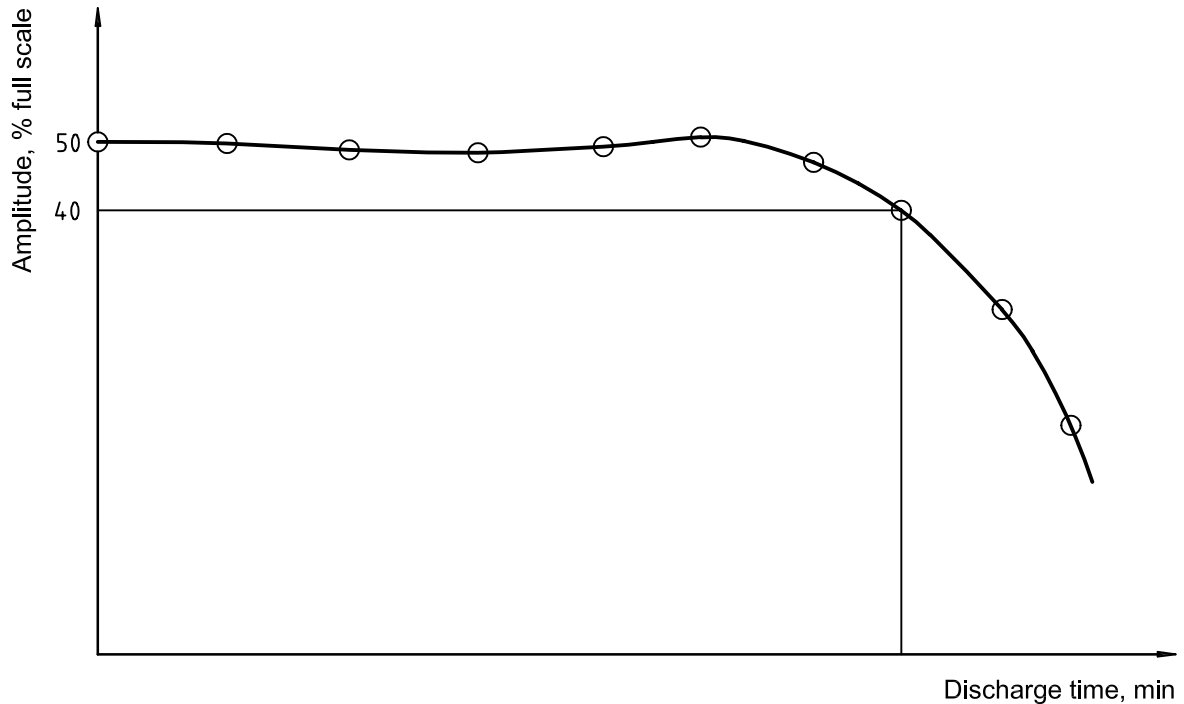

Figure 2 — Typical battery discharge characteristics

7.2.1.5 With the battery discharged in accordance with 7.2.1.3, disconnect the battery from the ultrasonic test instrument (6.1) and connect to a DC voltmeter (6.2). Measure and record the remaining voltage of the battery.

7.2.2 Charge time

7.2.2.1 With the instrument battery discharged in accordance with 7.2.1, turn the instrument power switch to the OFF or CHARGE position, connect the battery charger to the battery and begin charging the battery.

7.2.2.2 At time intervals ≤ 5 min, disconnect the charger, connect the DC voltmeter (6.2) to the battery terminals and record the battery voltage versus time as shown in Figure 3. The battery charge curve shown in Figure 3 is typical for Ni-Cd and sealed lead batteries used in most ultrasonic test instruments. The fully-charged condition corresponds to the maximum voltage value shown in Figure 3. Record these values in minutes.

7.2.2.3 The data recording may be minimized by making an initial reading and then beginning the periodic measurements at a later time near the anticipated charge time. Enough data should be acquired to reliably indicate the shape of the curve (see Figure 3) in the region of full charge.

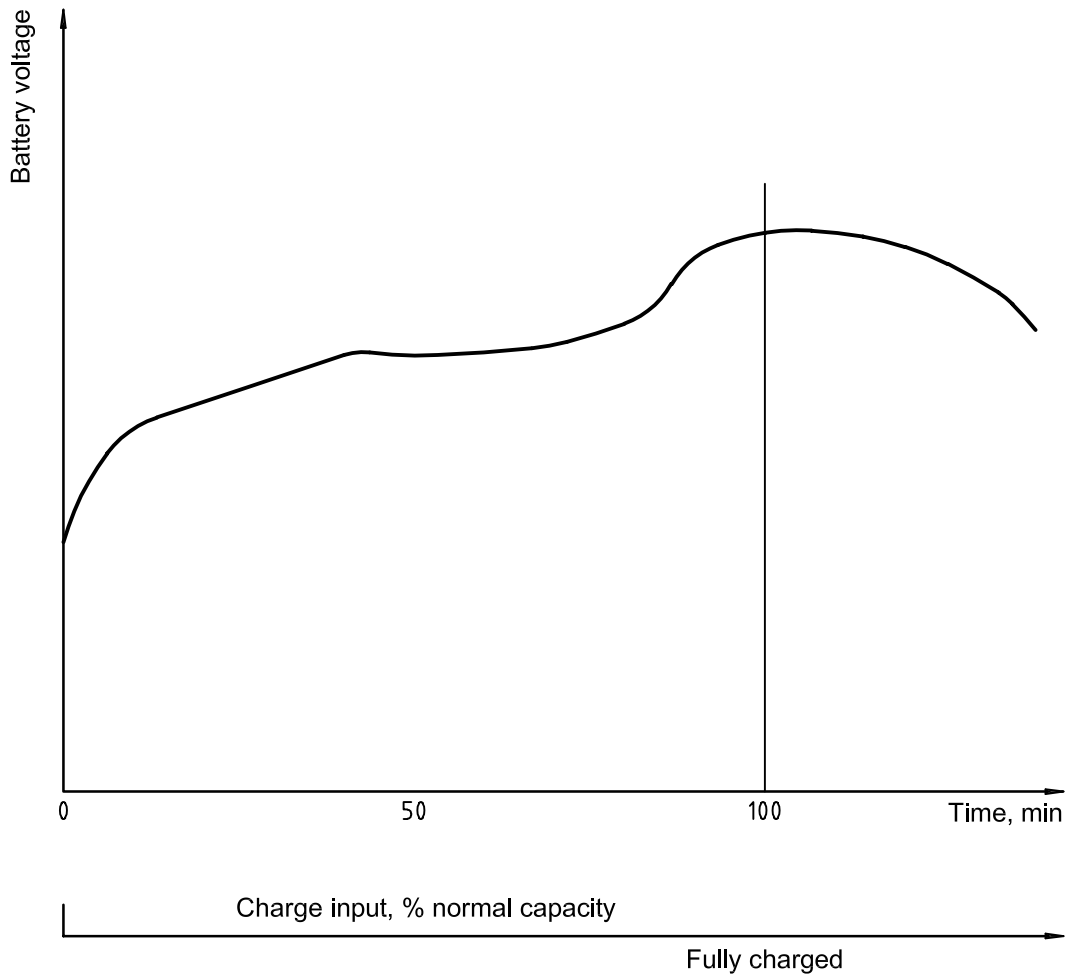
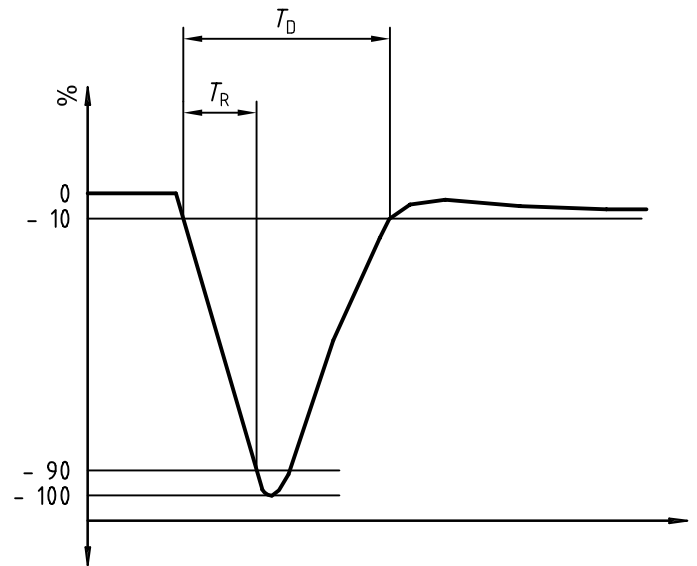

Figure 3 — Typical Ni-Cd and lead acid battery charge characteristics

8 Pulsar section measurements

8.1 General

Broadband pulsers generally produce negative spikes, such as is shown in Figure 4 a). If highly-damped (pulse length minimum), the exponential tail will be quite short. Another type of broadband pulse used in some instruments is a rectangular pulse (sometimes square), shown in Figure 4 b).



a) Spike (broad band)

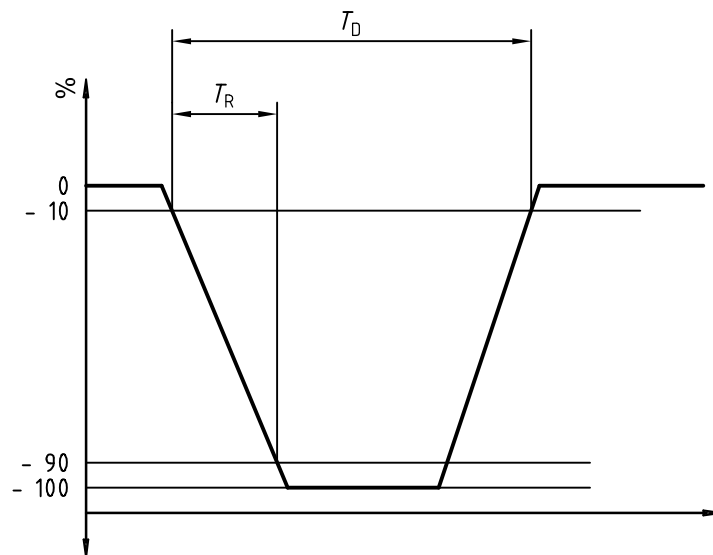

b) Square (broad band)

Figure 4 — Pulse shapes (slopes exaggerated)

8.2 Method

With the instrument turned on and no load connected to the pulser section output, connect the oscilloscope (6.9) to the pulser section using a $100\times$ or $50\times$ probe if needed. Adjust the oscilloscope gain and triggering controls to obtain a display of a pulser-module output pulse. Figure 5 shows the set-up. The Early Sync Trigger should be used, but if it is not available, an oscilloscope with built-in vertical signal delay will be needed to observe the leading edge of the pulse.

NOTE 1 Pulses involve very high frequency components. It is important to keep earth connections of probes short and close to the point of contact.

NOTE 2 In some commercial instruments, the PRF is under microprocessor control and not accessible to the operator. In such instruments the PRF does not necessarily follow the clock schedule and the oscilloscope display may appear unstable.

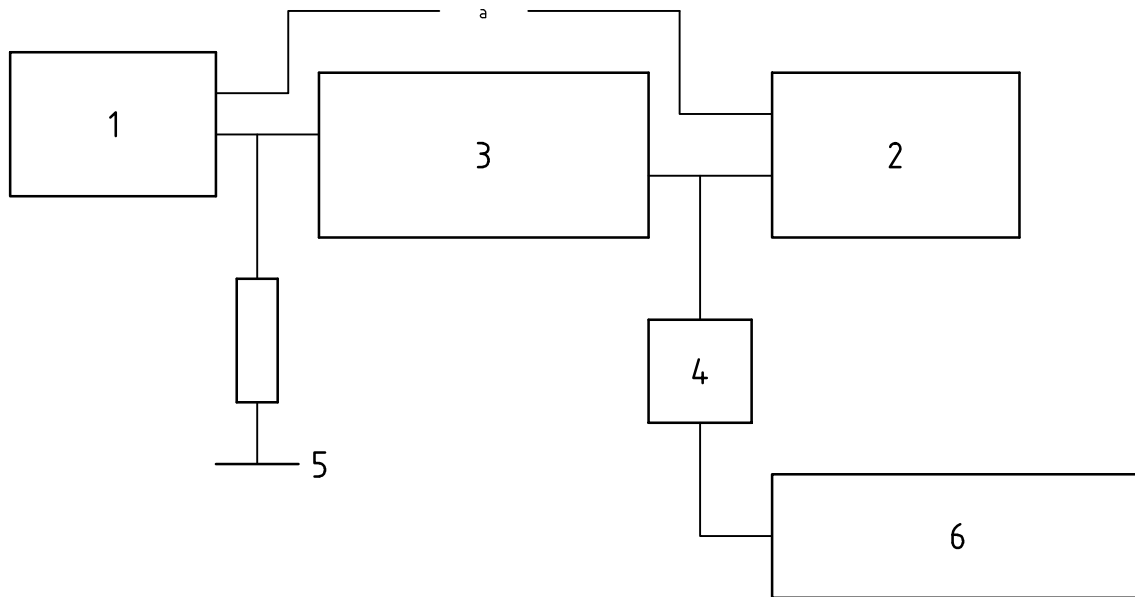

Key

- 1 Pulser section
- 2 Wide band oscilloscope
- 3 High impedance probe (50 ohm output)
- 4 50 ohm attenuator (optional)
- 5 Non-inductive 50 ohm load (omitted in some tests)
- 6 Spectrum analyser

a Early Sync

NOTE 1 Signal leads should be kept as short as possible.

NOTE 2 Probe needs an output of 50 ohm in order to match input attenuator or spectrum analyser or both.

Figure 5 — Instrumentation for pulse measurements

8.3 Pulse rise time, length and amplitude

8.3.1 Set-up

Start with the set-up of Figure 5 with the 50 ohm load connected. Obtain a display on the oscilloscope screen that clearly shows the leading edge of the pulse.

8.3.2 Pulse rise time

8.3.2.1 The rise time of the broadband pulse is the time interval T_r (in nanoseconds), between the 10 % and 90 % points (relative to peak amplitude) on the leading edge of the pulse (see Figure 4), whether the deflection is positive or negative.

NOTE The measured rise time includes the inherent rise times of the oscilloscope and probe if used. The actual rise time of the instrumentation is given by:

$$T_r^2 = T_m^2 - T_s^2$$

where

T_m is the measured rise time in nanoseconds;

T_s is the oscilloscope rise time in nanoseconds.

If only the bandwidth of the oscilloscope and probe are known, a close approximation to T_s can be calculated from:

$$T_s = 350 / BW$$

where BW is the bandwidth in MHz.

8.3.2.2 Measure and record the pulse rise time minimum at minimum pulse length and pulse rise time maximum at maximum pulse length.

8.3.2.3 Remove the 50 ohm load and repeat 8.3.2.2.

8.3.3 Pulse length

8.3.3.1 The pulse length of a tuned pulse is measured from 10 % of the peak amplitude of the first peak amplitude of the first large half cycle to the end of the last cycle that exceeds the 10 % level. This is illustrated in Figure 4 a).

8.3.3.2 The pulse length of the untuned pulse is the time between 10 % of peak on the leading edge and 10 % of peak on the trailing edges illustrated in Figures 4 a) and 4 b).

8.3.3.3 With the 50 ohm load in place for either pulse, measure and record pulse length minimum and pulse length maximum.

8.3.3.4 Remove the 50 ohm load and repeat 8.3.3.3.

8.3.4 Pulse amplitude

8.3.4.1 The pulse amplitude of a broad band pulse is the peak amplitude as shown in Figures 4 a) and 4 b).

8.3.4.2 With the 50 ohm load connected (see Figure 5), measure and record the pulse amplitude minimum for minimum pulse length and pulse amplitude maximum for maximum pulse length.

8.3.4.3 Remove the 50 ohm load and repeat 8.3.4.2.

8.4 Pulse frequency spectrum

8.4.1 Use the set-up of Figure 5. Start with sufficient attenuation to assure that the spectrum analyser input circuits will not be damaged or overloaded. The same frequency characteristics are measured at maximum and minimum pulse length. Other conditions may be prescribed.

8.4.2 Adjust the spectrum analyzer to obtain a linear display of amplitude versus frequency. Measurements shall be made with and without the 50 ohm load.

8.4.3 Record the peak frequency with and without the 50 ohm load. On the spectrum analyser display, this is the frequency corresponding to the highest amplitude.

8.4.4 Measure the pulse upper frequency limits, F_{UMAX} and F_{UMIN} , with pulse length controls at maximum and minimum respectively. The pulse upper frequency limit is the highest frequency that corresponds to 70,8 % of the amplitude at peak frequency.

8.4.5 Measure pulse lower frequency limits F_{LMAX} and F_{LMIN} with pulse length controls at maximum and minimum respectively. The pulse lower frequency limit is the lowest frequency that corresponds to 70,8 % of the amplitude at peak frequency.

NOTE In some instruments, the setting of the single search unit (pulse-echo)/double search unit (through transmission) switch may affect the results. If so, tests should be made with each setting.

9 Receiver section measurements

9.1 Vertical linearity

9.1.1 The receiver section vertical linearity shall be evaluated first because some other characteristics require vertical linearity for their measurement.

9.1.2 Connect the ultrasonic test instrument (6.1), electronic gate (6.8), function generator (6.7), oscilloscope (6.9), attenuator (6.10) and terminator (6.11) as shown in Figure 6.

9.1.3 The ultrasonic test instrument shall be in the double search unit mode to avoid possible damage to the function generator by the pulse voltage. If the double search unit is not available or if a substantial portion of the receiver is located before the double search unit input terminal, means shall be provided to protect the function generator from the pulser output. Consult the manufacturer's data. Also, unless otherwise specified, Reject and EDAC should be disabled.

9.1.4 If the receiver provides variable video filtering, the filtering control shall be set for minimum filtering. Also, unless otherwise specified, set the receiver Reject controls to off or minimum and disable the EDAC. Set the receiver frequency to the frequency range of interest and adjust the function generator to provide a sine wave burst of at least five cycles of rectangular envelope, the frequency of which corresponds to the instrument frequency setting.

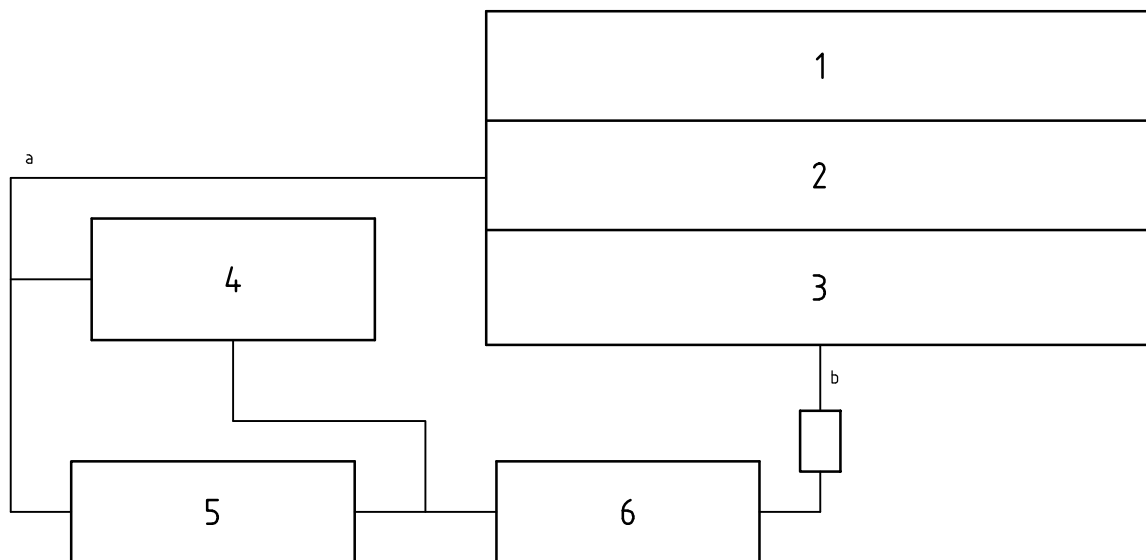

Key

- 1 Ultrasonic test equipment
- 2 Pulser section
- 3 Receiver section
- 4 Wide band oscilloscope
- 5 Function generator
- 6 Attenuator

- a Early Sync (if Early Pulse Sync is not available, use pulse output with suitable voltage reduction in order to prevent damage to successive instruments).
- b Attenuator termination (in some modern instruments, the receiver section input impedance may be low enough to require consideration in arranging the attenuator termination).
- c All signal leads after the function generator should be kept as short as possible.

Figure 6 — Instrumentation for receiver section bandwidth, sensitivity, noise, vertical linearity and time-base section linearity

9.1.5 If the receiver section gain control is comprised of a coarse and fine control, set the coarse control to its lowest setting and the fine control to its middle setting. If the receiver gain control is comprised of a single control, set it for approximately 25 % of its range. The input signal amplitude shall not exceed the manufacturer's recommendation.

9.1.6 Vary the function generator output or the attenuator to provide a deflection on the instrument display screen from 5 % to 100 % of full scale in increments of 5 % of full scale. Other increments may be used as convenient. Record and plot the amplitude indicated on the instrument display screen versus the input amplitude as shown in Figure 7. (It is recommended that multiple readings be taken and averaged at each input amplitude level to reduce operator-reading errors.)

9.1.7 Repeat the measurements of 9.1.6 using at least two other gain settings, one near mid range and one at approximately 75 % of maximum gain.

NOTE Very low gain may lead to serious nonlinearity due to over-driving the input circuits, and measurement at maximum gain may be difficult because of noise interference.

9.1.8 It will be noted that there are no tolerance limits shown on Figure 7. This curve is a performance characteristic of the vertical amplifier and the display. While it may show linearity or lack of it, it is not the function of this International Standard to set tolerance limits. This is the responsibility of the user in accordance with such documents as apply.

9.2 Receiver section frequency characteristics

9.2.1 Connect the ultrasonic test instrument, delayed trigger, function generator, oscilloscope, attenuator and terminator as shown in Figure 6. The oscilloscope is used to monitor the function generator output, which is the unattenuated input signal to the instrument receiver section. The instrument display is used to monitor the receiver output. Care should be taken to properly match the impedances of each portion of this system.

9.2.2 The ultrasonic test instrument should be in the double search unit mode to avoid possible damage to the function generator by the pulser output.

9.2.3 If the receiver provides variable video signal filtering, the filtering control shall be set for minimum or zero filtering. Set the receiver reject control to minimum or off. Set the receiver frequency control to the frequency range of interest and adjust the function generator to provide a five cycle sine wave burst whose frequency corresponds to the ultrasonic instrument frequency setting. Set the calibrated attenuator to 20 dB attenuation and adjust the delay to provide a signal located midway across the instrument display screen (the instrument sweep rate is irrelevant to these measurements.) By means of the receiver section gain controls and the function generator output, adjust the signal amplitude to 80 % full scale or 80 % of the upper linearity limit, whichever is less. A preliminary scan of the frequency range may be desirable in order to determine the frequency at which the response is at a maximum.

9.2.4 Vary the function generator frequency in 0,5 MHz increments above and below the receiver module frequency setting until the signal indication decreases to 10 % of its maximum value. At each frequency increment the function generator output shall be adjusted, if necessary, to ensure a constant amplitude input to the receiver. At each frequency record the signal amplitude and frequency and plot the results as in Figure 8.

9.2.5 If the ultrasonic test instrument is to be operated with video filtering, the measurements described above shall be repeated at the required filter settings.

9.3 Receiver frequency results

9.3.1 Peak frequency

The peak frequency is the frequency at which the instrument display indication is at a maximum. The peak frequency shall be determined to within $\pm 0,1$ MHz by decreasing the frequency increments in the range near the peak frequency. The peak frequency shall be determined for each setting of the receiver frequency control.

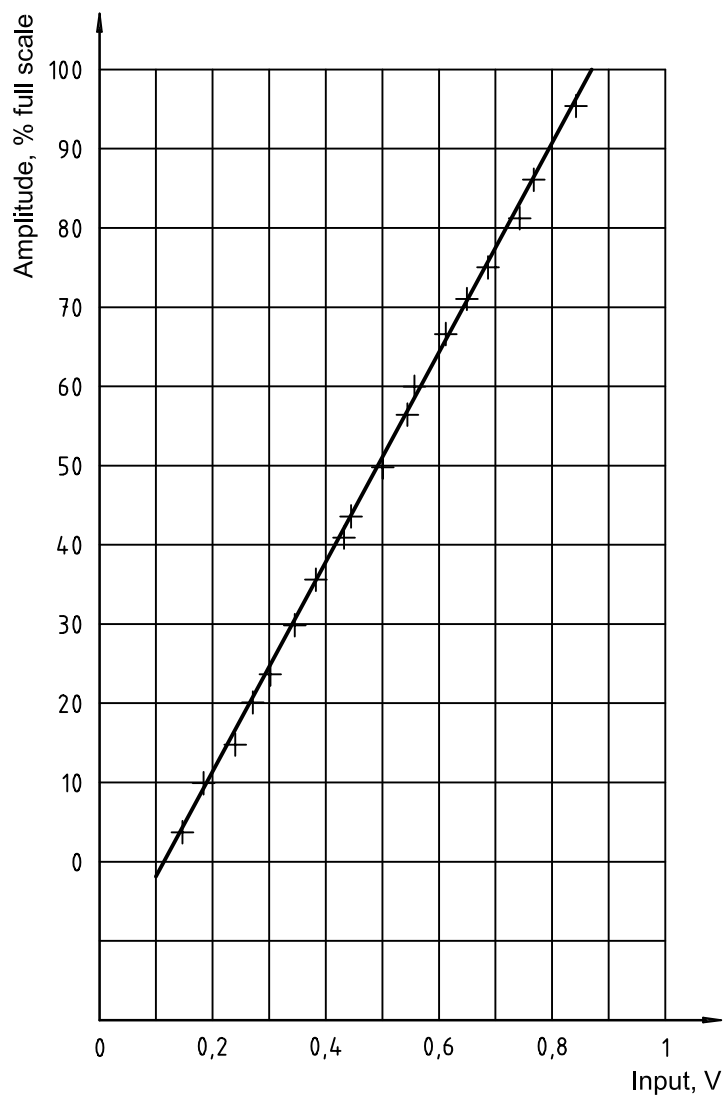

NOTE 1 Offset is due to detector threshold and other biasing components.

NOTE 2 Data points were taken using an actual instrument.

Figure 7 — Receiver section vertical linearity

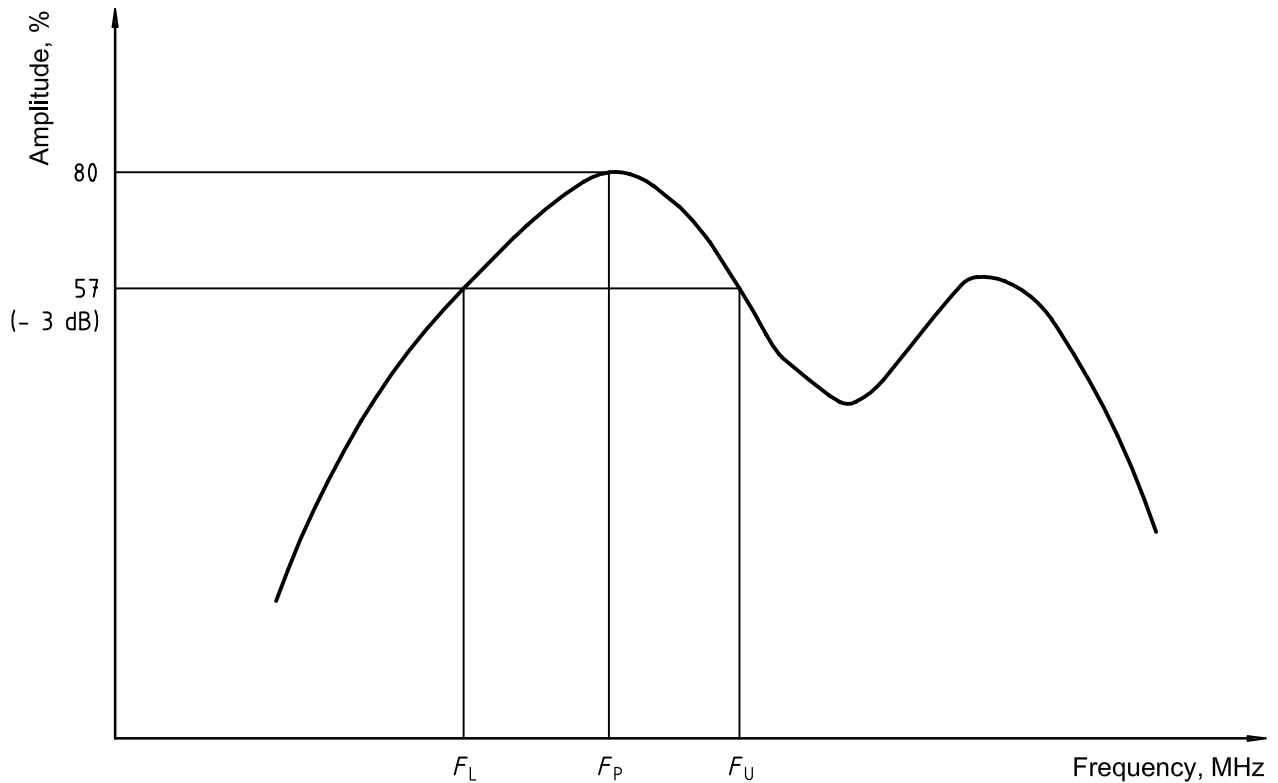

Figure 8 — Receiver section frequency characteristics

9.3.2 Bandwidth

The bandwidth is the response range between the frequencies at which the signal amplitude is 3 dB (29 %) below the amplitude at peak frequency. Record these frequencies as upper and lower frequency limits for each setting of the receiver frequency control.

9.4 Noise and sensitivity index

9.4.1 Set-up

Connect the ultrasonic test instrument and measuring equipment as shown in Figure 6. Set the receiver frequency control to the range of interest and set the function generator to the same frequency. Adjust the function generator to provide RF bursts of five or more cycles, but not more than ten.

9.4.2 Noise

9.4.2.1 Method A

Set the instrument gain at mid-range. Adjust the function generator output to give 20 % indication amplitude on the instrument display screen. Adjust the flaw alarm level until it is just triggered. Disconnect the function generator, leaving the 50 ohm terminator in place. Increase the instrument gain to maximum. If the noise is greater than 20 % reduce the gain until the alarm is no longer triggered. Reconnect the function generator and adjust the output to give a deflection of 80 %. Record the peak-to-peak output voltage. This voltage represents a 4:1 S/N (signal to noise ratio). If the voltage is too low to read accurately, remove sufficient attenuation to obtain a readable value and correct for the change in attenuation.

9.4.2.2 Method B

If the ultrasonic test instrument does not have a gate/alarm, the following method may be used. Increase the instrument gain to maximum. Connect the function generator and adjust the output to make the signal just blend with the noise on the instrument display screen. Record the function generator peak-to-peak output. This is the instrument noise referred to the input.

9.4.3 Sensitivity index

The input voltage measured in 9.4.2.1 can be taken as a sensitivity index defined as the input signal necessary to give a signal to noise ratio of 4:1. To apply this definition to 9.4.2.2, multiply the measured input by four. The resulting indices will not necessarily be equal.

9.5 dB controls (gain controls)

9.5.1 Connect the ultrasonic test instrument and measuring equipment as shown in Figure 6. Adjust the receiver to mid range. Set the external attenuator to a value at least as great as the amount of attenuation left in the receiver dB controls. Set the function generator for a single cycle sine or square wave and adjust the output to provide a signal at mid-screen, of amplitude approximately 50 % full screen. Note the starting value of the external attenuator and increase the dB controls by 6 dB and reduce the external attenuation to bring the signal back to its starting amplitude. Proceed in this manner through the full range of the dB controls, using the function generator output to reset the signal to 50 % full scale after each step if necessary.

9.5.2 Make a table or plot a graph of receiver dB controls settings against the external attenuator settings. This is the dB controls calibration table or curve.

10 Time base section measurements

10.1 Horizontal linearity (Method A)

Connect the ultrasonic test instrument and measuring equipment as shown in Figure 6 with the ultrasonic test instrument in the double search unit mode. Set the function generator to produce a single-cycle sine wave whose frequency corresponds to the instrument frequency setting. (Since this evaluation is independent of the instrument frequency, any instrument frequency setting may be chosen.) Adjust the display section coarse test range to its minimum range position and the fine range control approximately to its middle position. Adjust the ultrasonic test instrument and the calibrated attenuator to obtain an indication with at least 50 % full-scale amplitude located midway across the instrument display screen.

Vary the trigger delay in increments that move the indication in increments ≤ 5 % of the test range and record each delay (as measured on the oscilloscope) and the corresponding location of the leading edge of the indication on the display screen. Plot the location versus delay as shown in Figure 9.

10.2 Horizontal linearity (Method B):

10.2.1 Connect an immersion search unit, mounted in a conventional immersion scanning system, to the ultrasonic test instrument. Orient the search unit over any reflector. Adjust the instrument sweep controls to settings corresponding to the end use of this system and adjust the receiver gain and the water path between the reflector and the search unit to provide a 50 % full scale indication midway across the instrument display screen.

10.2.2 Vary the water path to move the indication in increments of approximately 5 % of full scale of the time base and record each water path distance and the corresponding location of the leading edge of the indication as a percentage of full scale of time base. Plot the signal position versus water path distance as shown in Figure 9 and as described in 10.1.

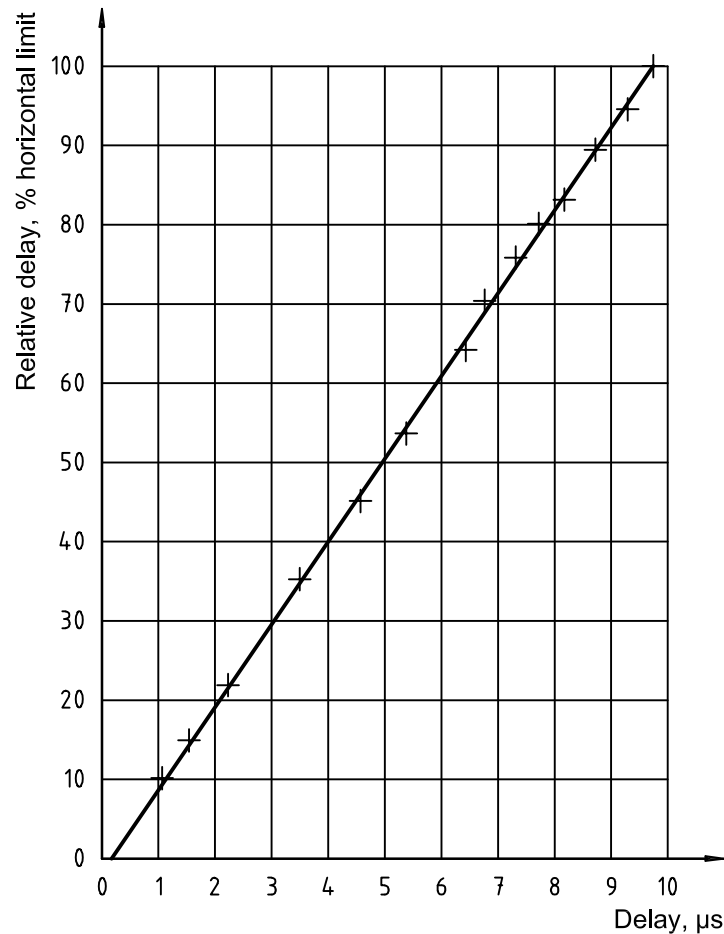

NOTE Data points were taken by Method A (see 9.4.2.1) using an actual instrument.

Figure 9 — Horizontal linearity

10.3 Horizontal linearity (Method C)

Connect the ultrasonic test instrument and a search unit for conventional contact or immersed operation as desired. Orient the search unit over a flat plate of suitable thickness in order to provide at least ten back reflections on the screen. Adjust controls to place the second reflection on the 10 % horizontal graticule line, and the tenth on the 90 % line. Plot the graticule positions of all the back reflections versus reflection number on a graph similar to Figure 9.

10.4 Horizontal linearity results

As stated in 9.1.8, this International Standard does not define tolerance limits. The graph of Figure 9 is simply a calibration curve of the horizontal base line.

10.5 Pulse repetition frequency (PRF)

Connect the oscilloscope to the ultrasonic test instrument pulse section output using a 100 \times or 50 \times probe. Adjust the oscilloscope to display at least two pulses. The repetition frequency is the reciprocal of the time between pulses. Because of possible interaction between the PRF and the test range control, verify that the PRF is not limited by the test range. If other functions, such as a DAC curve, gate strobe, etc., are displayed simultaneously with the ultrasonic signals on the instrument screen, the PRF as measured this way may be a sub-multiple of the time base repetition rate. To be sure of measuring the true PRF, these functions shall be disabled.

Measure and record the instrument repetition frequency, PRF-max. and PRF-min. (in pulses per second) for the maximum and minimum positions of the pulse PRF control.

If the ultrasonic test instrument has switch-selectable rates, record each switch value versus the measured PRF.

If the ultrasonic test instrument has both switch-selectable PRF and a variable control, record the maximum and minimum PRF at each switch setting.

11 Gate/alarm section measurements

11.1 Delay and width

Connect the ultrasonic test instrument and measuring equipment as in Figure 6. Adjust the function generator to one cycle of a high frequency (within the instrument bandwidth) and position this signal in the gate and mid-screen on the ultrasonic test instrument. Set the alarm level as low as possible, and the gate width at minimum. Move the signal toward the leading (left) edge of the gate. Continue until the alarm is deactivated. Move back until the alarm is just re-activated. Note on the oscilloscope the delay time of the signal. Move the signal to the other end of the gate and continue until the alarm is deactivated. Move back until the alarm just comes on. Note the delay time on the oscilloscope. The difference between the delay times on the oscilloscope is the minimum gate width. Increase the gate width to max. (adjusting the sweep length appropriately) and repeat. Delay max. and min. may be determined similarly: Set delay control to max. (again with test range adjustment, if necessary). Move the function generator signal to the leading edge of the gate. Read the delay time on the oscilloscope. This is the max. delay. In most instruments, the leading edge of the gate will be obscured by the "transmission pulse indication" at minimum delay. If it is not, set the delay at min. and move the signal to the leading edge again. The delay time on the oscilloscope is min. delay. If the gate strobe is available at a separate jack, it may be displayed on the oscilloscope and the delay times measured directly. There may be a small error in the times, due to internal circuitry in the instrument, which may be significant in the minimum delay measurement.

NOTE If double search unit mode is not available, means should be provided to protect the function generator output circuits from the pulser output. The manufacturer's data should state permissible signal levels to be fed in at the generator output.

11.2 Resolution

This term is used to refer to closeness of approach of a gate to an indication that is not to be gated.

Arrange the equipment to obtain a strong indication such as from a front or back surface reflection or a strong signal from the function generator. Adjust the sweep delay to position the indication about mid-sweep. Move the gate from left to right toward the indication until the indication activates the alarm. Note the delay on the oscilloscope. Back off until the alarm is no longer activated. Note the delay. The difference in delays is the time resolution. This may be converted to space resolution by multiplying by the velocity in the material.

Closeness of approach to the rear edge of a strong signal depends on the alarm level and the shape of the signal. For this reason it is not quantifiable.

11.3 Alarm level

11.3.1 Set-up

Set up the ultrasonic test instrument and obtain an indication from a suitable target or from a signal from the function generator. Position the gate to include the indication. Reduce the signal level to zero. Reduce the alarm level to minimum. Increase the indication height until the alarm is activated. Record the amplitude of the indication relative to the gate step, if present, as a percentage of full scale. This is the minimum alarm level. Readjust the alarm level control to maximum. Increase the indication amplitude until the alarm is again activated. This is the maximum alarm level. Repeat these measurements for negative alarm (negative alarm indicates absence of signal in the gate). All measurements shall be repeated several times in order to obtain an average.

NOTE For negative alarm, levels are determined by reducing the indication until the alarm is activated.

11.3.2 Alarm level hysteresis

Set the indication level to about 50 % of full scale of the instrument display screen. Position the gate to include the indication. Reduce the alarm level to just activate the alarm. Reduce the indication amplitude until the alarm is deactivated. Note the amplitude. Increase the amplitude until the alarm is re-activated. Note the change in amplitude. This is alarm level hysteresis. Repeat to get an average change, if measurable (ideally, the change would be zero, and it may well be too small to measure.) Do this for both positive and negative alarm. Hysteresis can cause exaggeration of size of indications in C-Scan recording.

11.4 Gain uniformity in the gate

Set up the equipment as in 11.3.1. Adjust the gate width to several times the width of the indication. Set the level so that the alarm is just activated and move the gate back and forth "through" the indication and note whether the alarm remains activated. Repeat with the alarm just not activated. Change of alarm status indicates lack of uniformity of gain in the gate. Record the gain change necessary to keep the alarm activated (or deactivated).

NOTE Alarm level hysteresis may obscure any gain variation.

11.5 Analog output

Using the procedures described in 9.1, record the analog output voltage as a function of input amplitude. Plot a graph of output versus input such as shown in Figure 7.

NOTE On some instruments the analog output may be "go-no-go" to indicate whether a screen indication amplitude is above or below the alarm level setting. Proportional output also may depend on the alarm level setting. Not all instruments provide an analog output.

11.6 Back echo gate

Some ultrasonic test instruments provide multiple gates, at least one of which may incorporate an independent gain control or attenuator. This gate is often used to monitor the amplitude of the strong reflection from the back surface of the test object. It is necessary that any change in amplitude of the back reflection be repeated by the indication in the gate. To test the performance of the gate, the arrangement of Figure 6 may be used (the oscilloscope is not needed).

Arrange for a saturated indication on the screen. Position it in the gate and, using the gate gain control, bring the indication down to 80 % of full screen. Vary the input in measured amounts and note the variation of the indication in the gate. Plot a graph, similar to Figure 7, of the amplitude of the indication versus the input. Repeat for various starting input amplitudes.

12 Reporting format

12.1 Identification of the instrumentation

The ultrasonic test instrument mainframe and plug-in modules shall be identified as to manufacturer model, serial numbers and other pertinent descriptors. The manufacturer, model and pertinent control settings of the electronic test instrumentation shall also be recorded. Any components of the instrument not tested or evaluated shall be so noted in the report.

12.2 Power supply section report

The following is the recommended power supply section measurement reporting format:

Power supply type:

AC-powered Battery powered

AC-powered measurements:

Permissible line regulation V % AC line voltage

DC-powered measurements:

Discharge time hours Charge time hours

12.3 Pulser section Report

The following is the recommended format for the pulser section measurement report:

Pulse rise time, length, amplitude and frequency spectrum:

Pulser load Ω

	<u>Min.</u>	<u>Max.</u>	<u>Units</u>
Pulse length	μ s
Rise time	ns
Amplitude	V
Lower bandwidth limit	MHz
Upper bandwidth limit	MHz
Peak frequency	MHz
Spectrum shape:	Smooth	Irregular	

12.4 Receiver section report

The following is the recommended format for reporting the receiver section measurements:

Vertical linearity

Plot Figure 7 for all frequency and gain settings of interest.

Frequency characteristics:

Frequency control setting MHz

Reject level ... % of full reject (preferably zero)

Filtering record: Filtering control position (preferably zero)

Lower frequency limit MHz

Upper frequency limit MHz Bandwidth MHz

Peak frequency MHz

(Repeat for each frequency control setting.)

Noise μ V (p-p)

Sensitivity index μ V (p-p) (4:1 S/N)

12.5 Time base section report

Horizontal linearity:

Plot Figure 9 for all PRF and test range of interest.

PRF:

Continuously variable control: Max PRF pps
 Min PRF pps
 Switched control: switch setting: PRF pps
 PRF pps
 PRF pps

12.6 Gate/alarm report

Width range Max ms Min μs

Delay range Max ms Min ns

Resolution: Alarm just actuated: Delay μs/ms
 Alarm off: Delay μs/ms
 Resolution: (difference) μs/ms

Alarm level: Minimum level % full scale
 Maximum level % full scale
 Hysteresis % full scale

Gain uniformity: Gain change to maintain alarm

Analog output Plot a graph of output as a function of input such as Figure 7 for all gain settings of interest, for both the main gate and the back surface gate.

Bibliography

- [1] ISO 5577:2000, *Non-destructive testing — Ultrasonic inspection — Vocabulary*
- [2] ISO 10375:1997, *Non-destructive testing — Ultrasonic inspection — Characterization of search unit and sound field*
- [3] ISO 12715:1999, *Ultrasonic non-destructive testing — Reference blocks and test procedures for the characterization of contact search unit beam profiles*
- [4] EN 12668-1, *Non-destructive testing — Characterization and verification of ultrasonic examination equipment — Part 1: Instruments*
- [5] EN 12668-3, *Non-destructive testing — Characterization and verification of ultrasonic examination equipment — Part 3: Combined equipment*
- [6] ASTM E 1324, *Standard Guide for Measuring Some Electronic Characteristics of Ultrasonic Examination Instruments*
- [7] JIS Z 2351, *Method for assessing the electrical characteristics of ultrasonic testing instruments using pulse echo technique*

ICS 19.100

Price based on 22 pages

© ISO 2002 – All rights reserved