**Graphic technology — Process control
for the production of half-tone colour
separations, proof and production
prints —**

Part 4:
Publication gravure printing

*Technologie graphique — Contrôle des processus de confection de
sélections couleurs tramées, d'épreuves et de tirages —*

Partie 4: Processus de gravure





COPYRIGHT PROTECTED DOCUMENT

© ISO 2014

All rights reserved. Unless otherwise specified, no part of this publication may be reproduced or utilized otherwise in any form or by any means, electronic or mechanical, including photocopying, or posting on the internet or an intranet, without prior written permission. Permission can be requested from either ISO at the address below or ISO's member body in the country of the requester.

ISO copyright office
Case postale 56 • CH-1211 Geneva 20
Tel. + 41 22 749 01 11
Fax + 41 22 749 09 47
E-mail copyright@iso.org
Web www.iso.org

Published in Switzerland

Contents

	Page
Foreword	iv
Introduction	v
1 Scope	1
2 Normative references	1
3 Terms and definitions	2
4 Requirements	2
4.1 General	2
4.2 Data file and printing forme	3
4.3 On-press proof and production print	4
Annex A (informative) Gamut types	8
Annex B (informative) Grey reproduction and grey balance	13
Bibliography	17

Foreword

ISO (the International Organization for Standardization) is a worldwide federation of national standards bodies (ISO member bodies). The work of preparing International Standards is normally carried out through ISO technical committees. Each member body interested in a subject for which a technical committee has been established has the right to be represented on that committee. International organizations, governmental and non-governmental, in liaison with ISO, also take part in the work. ISO collaborates closely with the International Electrotechnical Commission (IEC) on all matters of electrotechnical standardization.

The procedures used to develop this document and those intended for its further maintenance are described in the ISO/IEC Directives, Part 1. In particular the different approval criteria needed for the different types of ISO documents should be noted. This document was drafted in accordance with the editorial rules of the ISO/IEC Directives, Part 2 (see www.iso.org/directives).

Attention is drawn to the possibility that some of the elements of this document may be the subject of patent rights. ISO shall not be held responsible for identifying any or all such patent rights. Details of any patent rights identified during the development of the document will be in the Introduction and/or on the ISO list of patent declarations received (see www.iso.org/patents).

Any trade name used in this document is information given for the convenience of users and does not constitute an endorsement.

For an explanation on the meaning of ISO specific terms and expressions related to conformity assessment, as well as information about ISO's adherence to the WTO principles in the Technical Barriers to Trade (TBT) see the following URL: Foreword - Supplementary information

The committee responsible for this document is ISO/TC 130, *Graphic technology*.

This second edition cancels and replaces the first edition (ISO 12647-4:2005), which has been technically revised with the following changes:

- deletion of film based requirements;
- changes in proof requirements;
- changes in printing conditions;
- changes in the colouration of the primary and secondary solids;
- general clean up.

ISO 12647 consists of the following parts, under the general title *Graphic technology — Process control for the production of half-tone colour separations, proof and production prints*:

- *Part 1: Parameters and measurement methods*
- *Part 2: Offset lithographic processes*
- *Part 3: Coldset offset lithography on newsprint*
- *Part 4: Publication gravure printing*
- *Part 5: Screen printing*
- *Part 6: Flexographic printing*
- *Part 7: Proofing processes working directly from digital data*
- *Part 8: Validation print processes working directly from digital data*

Introduction

This part of ISO 12647 lists values or sets of values of the primary process parameters specified in ISO 12647-1 and related technical properties of a gravure publication print. Where deemed useful, secondary parameters are also specified.

The purposes of this part of ISO 12647 are:

- to list and explain the minimum set of primary process parameters required to uniquely define the visual characteristics and related technical properties of a half-tone proof or production print produced from digital data;
- to give the definitions for the general terms necessary for process control;
- to describe the measurement methods and the requirements for reporting the results.

The purpose of a proof print is to simulate the visual characteristics of the finished print product as closely as possible. In order to visually simulate particular print, off-press proofing processes might require values for solid tone coloration and tone value increase which are different from those of the printing process they are meant to simulate. This is caused by differences in phenomena such as gloss, light scatter (within the print substrate or the colorant), metamerism, and transparency. Such differences are likely for those off-press proofing processes in which the print substrate, the colorants, and the technology for applying them are significantly different from gravure publication printing. In such cases, the user or the supplier should ensure that appropriate corrections are specified. Another problem area is the matching of a digital off-press proof to a double-sided print on a less-than-opaque, lightweight printing paper as used in publication gravure printing. If it is deemed necessary, for image quality reasons, to proof with colour management profiles based on measurements with substrate backing rather than black backing, there will be an unavoidable difference between proof and production prints. This fact needs to be communicated to all parties concerned.

Graphic technology — Process control for the production of half-tone colour separations, proof and production prints —

Part 4: Publication gravure printing

1 Scope

This part of ISO 12647 specifies a number of process parameters and their values to be applied to four-colour publication gravure printing. The parameters and values are chosen in view of the complete process covering the process stages “colour separation”, “making of the printing forme”, “proof production”, and “production printing”.

This part of ISO 12647 is applicable,

- directly, to publication gravure printing, including magazines, catalogues, and commercial materials,
- directly, to half-tone and continuous tone proofing processes that predict the colourimetric results of gravure printing, and
- by analogy, to process-colour gravure package printing.

It is not directly applicable to the specifics of the transformations necessary to relate digital input data to the data used to create the cylinder engraving data and/or the proofing process.

2 Normative references

The following documents, in whole or in part, are normatively referenced in this document and are indispensable for its application. For dated references, only the edition cited applies. For undated references, the latest edition of the referenced document (including any amendments) applies.

ISO 8254-1, *Paper and board — Measurement of specular gloss — Part 1: 75 degree gloss with a converging beam, TAPPI method*

ISO 12642-2, *Graphic technology — Input data for characterization of 4-colour process printing — Part 2: Expanded data set*

ISO 12647-1, *Graphic technology — Process control for the production of half-tone colour separations, proof and production prints — Part 1: Parameters and measurement methods*

ISO 12647-7, *Graphic technology — Process control for the production of half-tone colour separations, proof and production prints — Part 7: Proofing processes working directly from digital data*

ISO 13655:2009, *Graphic technology — Spectral measurement and colorimetric computation for graphic arts images*

ISO 15930-4, *Graphic technology — Prepress digital data exchange using PDF — Part 4: Complete exchange of CMYK and spot colour printing data using PDF 1.4 (PDF/X-1a)*

ISO 15930-6, *Graphic technology — Prepress digital data exchange using PDF — Part 6: Complete exchange of printing data suitable for colour-managed workflows using PDF 1.4 (PDF/X-3)*

ISO 15930-7, *Graphic technology — Prepress digital data exchange using PDF — Part 7: Complete exchange of printing data (PDF/X-4) and partial exchange of printing data with external profile reference (PDF/X-4p) using PDF 1.6*

3 Terms and definitions

For the purposes of this document, the terms and definitions given in ISO 12647-1 and the following apply.

3.1 improved newsprint

paper with, compared to ordinary newsprint, a higher smoothness, a higher brightness, and a filler content up to 20 %

3.2 engraving pitch

P

reciprocal of average cell spacing on a gravure cylinder, evaluated from the following formula:

$$P = (a \times b)^{-1/2}$$

where

- a is the distance between the same points on two adjacent cells in the printing direction;
- b is the distance between adjacent circumferential tracks of the engraving stylus.

3.3 solid colour

printed area that corresponds to the maximum cell volume identified for the combination of gravure engraving parameters

4 Requirements

4.1 General

[4.2](#) and [4.3](#) are based on the assumption that input for gravure printing comprises digital data that defines the data tone values (equivalent to the tone values in offset processes). The specifics of the transformations necessary to relate these data to the data used to create the cylinder engraving data and/or the proofing process are the responsibility of the organization involved and are not specified in this part of ISO 12647.

The substrate categories of gravure printing, identified by the paper principally used, defined for this part of ISO 12647, are as follows:

For Gamut Type 1

- substrate category S1 (coated paper of 70 g/m² or greater);
- substrate category S2 (lightweight coated paper);
- substrate category S3 (“combined LWC paper and SC paper”);
- NOTE CRPC 5 of ANSI.
- substrate category S4 (super-calendered paper);
- substrate category S5 (improved or enhanced newsprint);

For Gamut Type 2

- substrate category S1 (LWC plus, improved lightweight coated paper);
- substrate category S2 (LWC standard, standard lightweight coated paper);
- substrate category S3 (SC plus, improved super-calendered paper);
- substrate category S4 (SC standard, standard super-calendered paper);
- substrate category S5 (News plus, improved newsprint).

While these substrate categories of gravure printing are identified in terms of the paper principally used, they can be used on any stock for which the printer is capable of achieving the colours specified in [Tables A.1](#) or [A.2](#), see also [Figures A.1](#) and [A.2](#), and thus the associated colour gamut.

Where appropriate, the applicable clauses of ISO 12647-1 are referenced for the definition of the data and measurement conditions.

[4.2](#) and [4.3](#) are arranged according to the order set out in ISO 12647-1; they also depend on it for the general principles, the definition of the data, the measurement conditions, and the reporting style.

In the absence of any other agreements between the print provider and printer, data intended for publication gravure printing in North America shall be prepared for and proofed based upon Characterized Reference Printing Condition (CRPC) 5 of ANSI CGA/TS 21-2. For this situation, it shall be the responsibility of the gravure printer to match the appearance defined by CRPC 5 to the satisfaction of the publisher. CRPC 5 is compatible with printing condition S3, Gamut Type 1.

4.2 Data file and printing forme

4.2.1 Data files

Digital data files supplied for printing should conform to the latest edition of ISO 15930-4, ISO 15930-6, and ISO 15930-7 or to ISO 12639.

Supplied data files conforming to ISO 15930-4, ISO 15930-6, and ISO 15930-7 shall also include an identification of the intended printing condition. Where the intended printing condition is a printing condition included in the registry of characterizations maintained by the ICC, as described in ICC.1, the name used in the ICC registry can be used as the identification. If the intended printing condition is not included in the ICC registry, characterization data specified using the target defined in ISO 12642-2, or an ICC output profile derived from it, shall be included. An ICC output profile derived from the appropriate characterization data should also be included in all cases. In any situations where the rendering of the data, when printed, is intended to be other than colourimetric (as specified in ICC.1) an ICC output profile derived from the appropriate characterization data shall be included.

All continuous tone raster data (CT) shall be at a resolution that equals or exceeds 120 cm⁻¹. If line work raster data (LW) are provided, they shall be at a resolution of three to six times that of the continuous tone data. If text is provided as CT data it should be anti-aliased.

A proof print can accompany digital data and where provided, it shall conform to the indicated printing condition.

4.2.2 Off-press proof from digital data

The off-press proof is a simulation of the intended gravure printing condition. It is produced directly from the data used to prepare the separations. Off-press hardcopy proofing shall be accomplished according to ISO 12647-7. The control patches provided shall, as a minimum, simulate the following patches:

- a) solid primary and secondary colours (including black);

- b) at least one half-tone control patch of each of the primary colours (including black) with tone values between 40 % and 70 %; the tone values used shall be the same for each colour;
- c) a tertiary colour control patch composed of 100 % each of the primary colours (or with magenta and yellow reduced to better approximate a grey);
- d) at least one tertiary colour patch composed of the same tone values as defined in b) (or with magenta and yellow reduced to better approximate a grey).

4.2.3 Engraving pitch

For four-colour work, the ranges of engraving pitch shall be

- a) 54 cm⁻¹ to 70 cm⁻¹ for yellow,
- b) 60 cm⁻¹ to 80 cm⁻¹ for cyan and for magenta, and
- c) 60 cm⁻¹ to 100 cm⁻¹ for black.

4.2.4 Image size tolerance

See [4.3.4](#).

4.2.5 Tone value sum

Unless otherwise specified, the maximum tone value sum shall be <340 %.

NOTE Smaller values can be used but this applies to a lesser extent to uncoated papers.

4.2.6 Grey reproduction and grey balance

A single grey balance condition is usually not sufficient to ensure an achromatic colour for all print substrates and printing inks that can be used with a given printing process. Therefore the grey balance has to be determined for each printing condition separately based on a well-defined grey reproduction. See [Annex B](#) for detailed information.

4.3 On-press proof and production print

4.3.1 General

To define the appearance of a print or proof, it is necessary, as a minimum, to specify the gloss and colourimetric characteristics of the substrate and inks used for printing when the inks are printed at the appropriate concentration. These characteristics are defined in [4.3.2](#) to [4.3.5](#). A typical print substrate, such as LWC paper and SC paper, has commonly used characteristics. This does not imply that other substrates are not suitable for this application or cannot be used to reach the specified colour gamut. [Table 1](#) provides a survey of the typical print substrates (Gamut Type 1, Gamut Type 2).

Table 1 — Standard printing conditions for typical print substrates (survey)

Printing Conditions Gamut Type 1	Print Substrate Description (see Table 2)	Colorant Description (Substrate Coordinates, see Table A.1)	Printing Conditions Gamut Type 2	Print Substrate Description (see Table 2)	Colorant Description (Substrate Coordinates, see Table A.2)
PC1 Gamut 1	PS1 Gamut 1	CD1 Gamut 1	PC1 Gamut 2	PS1 Gamut 2	CD1 Gamut 2
PC2 Gamut 1	PS2 Gamut 1	CD2 Gamut 1	PC2 Gamut 2	PS2 Gamut 2	CD2 Gamut 2
PC3 Gamut 1	PS3 Gamut 1	CD3 Gamut 1	PC3 Gamut 2	PS3 Gamut 2	CD3 Gamut 2

Table 1 (continued)

Printing Conditions Gamut Type 1	Print Substrate Description (see Table 2)	Colorant Description (Substrate Coordinates, see Table A.1)	Printing Conditions Gamut Type 2	Print Substrate Description (see Table 2)	Colorant Description (Substrate Coordinates, see Table A.2)
PC4 Gamut 1	PS4 Gamut 1	CD4 Gamut 1	PC4 Gamut 2	PS4 Gamut 2	CD4 Gamut 2
PC5 Gamut 1	PS5 Gamut 1	CD5 Gamut 1	PC5 Gamut 2	PS5 Gamut 2	CD5 Gamut 2

NOTE Colourimetric characterization data, as specified in this standard, contain all the data to be specified in accordance with 4.3.2.1, 4.3.2.3, 4.3.3, and 4.3.5.

4.3.2 Visual characteristics of image components

4.3.2.1 Print substrate colour

The print substrate used for proofing should be identical to that of the production printing. If this is not possible, the properties of the print substrate shall be a close match to that of the production in terms of colour, gloss, type of surface (coated, uncoated, super-calendered, etc.) and mass per area. Table 2 provides aim values for colour as well as other attributes for the substrate categories mentioned in 4.1.

NOTE All values in Table 2 except for the a^* and b^* values of the substrate are informative only.

4.3.2.2 Print substrate gloss

The gloss of the print substrate used for proofing should be a close match to that of the production print substrate. If this is not possible, press proofing shall be carried out on the closest simulation selected from the substrate categories listed in 4.1.

Table 2 — CIELAB coordinates, gloss, roughness, and tolerances for the substrate categories

Substrate category Gamut Type 1	$L^{*a,b}$	a^{*a}	b^{*a}	Gloss ^c	Roughness ^d μm	Mass per area g/m^2
S1: coated	91 (88)	0 (0)	-3 (-3)	65	0,9	80
S2: lightweight coated (LWC)	90 (87)	1 (0)	3 (2)	55	1,1	51
S3: Combined LWC-SCA	90 (87)	0 (-1)	3 (2)	—	—	—
S4: super-calendered (SC)	89 (86)	0 (-1)	4 (3)	45	1,5	52
S5: improved newsprint	84 (83)	0 (-1)	4 (3)	<10	3,5	50
Tolerances	—	± 2	± 2	± 10	—	—
Substrate category Gamut Type 2	$L^{*a,b}$	a^{*a}	b^{*a}	Gloss ^c	Roughness ^d μm	Mass per area g/m^2
S1: LWC plus (lightweight coat.)	94 (93)	0 (0)	0 (-1)	65	0,9	70
S2: LWC standard (lightweight coat.)	90 (87)	1 (0)	3 (1)	55	1,1	48
S3: SC plus (super-calendered)	91 (89)	1 (0)	2 (0)	50	1,5	52

^a Measurement in accordance with ISO 13655 (M0): D50 illuminant, 2° observer, 0/45 or 45/0 geometry, white backing. Values for black backing measurement are in brackets, informative. Gamut Type 2 substrates: substrate backing (sb) instead of white backing.

^b The L^* is informative only, values are representing a minimum.

^c Measurement in accordance with ISO 8254-1, TAPPI method, informative only.

^d Measurement in accordance with ISO 8791-4, Parker Print-surf, clamping pressure 980 kPa, soft backing, informative only.

Table 2 (continued)

Substrate category Gamut Type 1	$L^*_{a,b}$	a^*_{a}	b^*_{a}	Gloss ^c	Roughness ^d μm	Mass per area g/m ²
S4: SC standard (super-calend.)	89 (86)	-1 (-1)	5 (3)	45	1,5	52
S5: News plus (improved NP)	89 (86)	0 (-1)	4 (2)	<10	3,5	55
Tolerances	—	±2	±2	±10	—	—

a Measurement in accordance with ISO 13655 (M0): D50 illuminant, 2° observer, 0/45 or 45/0 geometry, white backing. Values for black backing measurement are in brackets, informative. Gamut Type 2 substrates: substrate backing (sb) instead of white backing.

b The L^* is informative only, values are representing a minimum.

c Measurement in accordance with ISO 8254-1, TAPPI method, informative only.

d Measurement in accordance with ISO 8791-4, Parker Print-surf, clamping pressure 980 kPa, soft backing, informative only.

4.3.2.3 Ink set colours

For proof and production printing, the aim value set shall be selected either from the Gamut Type 1 set or the Gamut Type 2 set. Both sets are specified in Annex A for four substrate categories, see Tables A.1 and A.2 and Figures A.1 and A.2.

For the digital proofprint, the CIELAB ΔE^*_{ab} deviation of the primary colour solids from the corresponding colours of the chosen set, defined by Tables A.1 or A.2 shall not exceed 4.

For the OK print, the CIELAB ΔE^*_{ab} deviation of the primary colours from the corresponding colours of the chosen set, defined by Tables A.1 or A.2 shall not exceed 5.

NOTE 1 If the tolerances of the primary colours of the proof and those of the production prints are being exploited in opposite directions, the maximum ΔE^*_{ab} between them shall not exceed 5.

For the production run, the variability of the primary colour solids is restricted by the following condition. For at least 68 % of the production prints, the colour differences from the OK sheet shall not exceed, and should not exceed one half of, the appropriate variation tolerance specified in Table 3.

NOTE 2 The distribution of ΔE^*_{ab} values is not Gaussian but skewed. For reasons of consistency, the variation tolerance is defined here as the upper limit for 68 % of the production copies. This is in analogy with a Gaussian distribution where 68 % are within plus or minus one standard deviation of the mean.

Table 3 — CIELAB ΔE^*_{ab} variation tolerances for the solids of the process colours

Unit: 1

	Black	Cyan	Magenta	Yellow
Variation tolerance CIELAB ΔE_{ab}	3,5	3,5 ^b	3,5 ^b	4,5 ^b
Variation tolerance CIELAB ΔE_{00}^a	3,5	2,5 ^b	2,5 ^b	3,2 ^b

a Tolerance values for DE2000 are given for information only.

b The magnitude of the hue difference shall not exceed CIE ΔH 3.

4.3.2.4 Ink set gloss

The gloss of solid tone colours can be specified if deemed necessary.

NOTE The gloss of the shadow parts of an image increases with increasing tone value sum.

The specular gloss of the print substrate or ink set single print solid areas shall be measured with light incident at 75° (15° from the plane of the print substrate) and measured at 75°. The instrument used shall conform to ISO 8254-1. Report values in percent, quoting ISO 8254-1 as the method.

4.3.3 Tone value reproduction limits

Tone values within the tone value limits in the digital data file from $\geq 3\%$ to $\leq 95\%$ shall be printable in a consistent and uniform manner. No significant image parts shall rely on tone values outside of the above tone value reproduction limits.

4.3.4 Tolerance for image positioning

The maximum deviation between the image centres of any two printed colours shall not be larger than 0,2 mm and the image size deviation between any two printed colours due to cylinder making and printing shall not exceed 0,2 mm.

4.3.5 Tone value increase

Both proof print and production print shall work with the same colour management profile for the intended printing condition. The tone value increases of both prints, calculated from the colourimetric data using the method described in ISO 12647-1, shall be within 2 % of the profile data. Informative values of the densitometric tone value increase are given in [Table 4](#) for the benefit of print run process control.

NOTE Due to the properties of the gravure printing process, there is no “tone value increase (TVI)” like in offset printing processes. However, similar colour reproduction curves (gradation curves) are in use and the “tone value increase (TVI)” model is applicable.

Table 4 — Typical tone value increase values
(informative only)

Unit: %

Tone value	Tone value increase
25	13
40	17
50	18
70	15
75	13
80	11

Annex A (informative)

Gamut types

A.1 General

Due to differing requirements in some geographical areas, two different gamut types have evolved, based on two different ink sets:

- Gamut Type 1, see [Table A.1](#) and [Figure A.1](#);
- Gamut Type 2, see [Table A.2](#) and [Figure A.2](#).

NOTE Gamut Type 1 and Gamut Type 2 are achievable with ink sets specified in ISO 2846-3.^[4]

In [A.2](#), no density values are specified. Such values can be very valuable for process control during a print run, where the densitometer, the ink and the print substrate remain the same, see ISO 12647-1. However, in a general situation, density values do not define a colour to the required degree. Following ISO 12647-1, the production press operator should first achieve the correct colour of the solids on the press, then read the densities with the densitometer from the OK print. These densities can then be used as aim values for process control during the production run.

A.2 Gamut type 1

Table A.1 — CIELAB coordinates of print substrate, solid colours for Gamut Type 1

Unit: 1

Gamut Type 1		Print substrate ^a														
		Coated			LWC			Combined LWC-SCA			SC			Improved news-print		
Colour		Coordinates ^d			Coordinates ^d			Coordinates ^d			Coordinates ^d			Coordinates ^d		
		<i>L*</i>	<i>a*</i>	<i>b*</i>	<i>L*</i>	<i>a*</i>	<i>b*</i>	<i>L*</i>	<i>a*</i>	<i>b*</i>	<i>L*</i>	<i>a*</i>	<i>b*</i>	<i>L*</i>	<i>a*</i>	<i>b*</i>
Gamut Type 1		Printing condition ^a														
		S1 ^a			S2 ^a			S3 ^a			S4 ^a			S5 ^a		
Colour		Coordinates ^b			Coordinates ^b			Coordinates ^b			Coordinates ^b			Coordinates ^b		
		<i>L*</i>	<i>a*</i>	<i>b*</i>	<i>L*</i>	<i>a*</i>	<i>b*</i>	<i>L*</i>	<i>a*</i>	<i>b*</i>	<i>L*</i>	<i>a*</i>	<i>b*</i>	<i>L*</i>	<i>a*</i>	<i>b*</i>
Black	WB	12	0	0	13	0	0	17	0	1	16	1	1	22	1	2
	BB	12	0	0	13	0	0	17	0	1	16	1	1	22	1	2

NOTE 1 The secondary colours red, green, blue might vary depending on conditions that include the printing sequence, the surface characteristics of the print substrate, and the rheological and transparency properties of the inks. Thus, conformance of the primaries C, M, Y to this table is not sufficient for the conformance of the secondary colours to this table.

NOTE 2 WB: white backing values (normative); BB: black backing values (informative only).

^a Substrate categories according to [4.1](#) and [Table 2](#).

^b Measurements to ISO 13655, (M0) with D50 illuminant, 2° observer, 0/45 or 45/0 geometry. Lower row values are measured over black. Upper row: measurement over white ($C^* < 3,0$; $L^* > 92,0$).

^c Printing sequence: yellow, magenta, cyan; these values are informative only.

^d L^* , a^* , and b^* coordinates (BB and WB values) for print substrates, see [Table 2](#).

Table A.1 (continued)

Gamut Type 1		Print substrate ^a														
		Coated			LWC			Combined LWC-SCA			SC			Improved news-print		
Colour		Coordinates ^d			Coordinates ^d			Coordinates ^d			Coordinates ^d			Coordinates ^d		
		L*	a*	b*	L*	a*	b*	L*	a*	b*	L*	a*	b*	L*	a*	b*
Gamut Type 1		Printing condition ^a														
		S1 ^a			S2 ^a			S3 ^a			S4 ^a			S5 ^a		
Colour		Coordinates ^b			Coordinates ^b			Coordinates ^b			Coordinates ^b			Coordinates ^b		
		L*	a*	b*	L*	a*	b*	L*	a*	b*	L*	a*	b*	L*	a*	b*
Cyan	WB	47	-32	-53	47	-30	-50	54	-32	-41	46	-26	-39	49	-23	-34
	BB	45	-31	-51	45	-30	-49	52	-31	-41	46	-26	-40	48	-23	-34
Magenta	WB	46	72	3	46	71	3	48	70	2	46	63	1	47	59	1
	BB	44	70	3	44	67	2	47	67	0	46	62	0	46	58	0
Yellow	WB	87	-2	92	86	-2	90	85	-3	86	80	-3	70	79	-3	60
	BB	84	-2	89	83	-4	87	82	-3	82	80	-4	70	78	-4	59
Red ^c	WB	46	74	55	45	70	52	46	69	49	44	59	41	46	53	36
	BB	44	72	53	43	66	50	44	66	46	44	58	41	45	52	35
Green ^c	WB	41	-67	28	42	-65	27	48	-60	30	38	-50	19	46	-43	17
	BB	40	-64	27	40	-63	26	46	-59	28	38	-50	19	45	-43	16
Blue ^c	WB	14	20	-42	15	19	-39	22	17	-39	16	16	-34	27	13	-29
	BB	14	19	-40	15	18	-38	21	17	-39	16	16	-34	27	12	-29
Overprint ^c Y+M+C	WB	12	0	0	14	0	0	17	2	0	15	0	-1	15	0	-1
	BB	12	0	0	14	0	0	17	2	0	15	0	-1	15	0	-1

NOTE 1 The secondary colours red, green, blue might vary depending on conditions that include the printing sequence, the surface characteristics of the print substrate, and the rheological and transparency properties of the inks. Thus, conformance of the primaries C, M, Y to this table is not sufficient for the conformance of the secondary colours to this table.

NOTE 2 WB: white backing values (normative); BB: black backing values (informative only).

^a Substrate categories according to 4.1 and Table 2.

^b Measurements to ISO 13655, (M0) with D50 illuminant, 2° observer, 0/45 or 45/0 geometry. Lower row values are measured over black. Upper row: measurement over white ($C^* < 3,0$; $L^* > 92,0$).

^c Printing sequence: yellow, magenta, cyan; these values are informative only.

^d L^* , a^* , and b^* coordinates (BB and WB values) for print substrates, see Table 2.

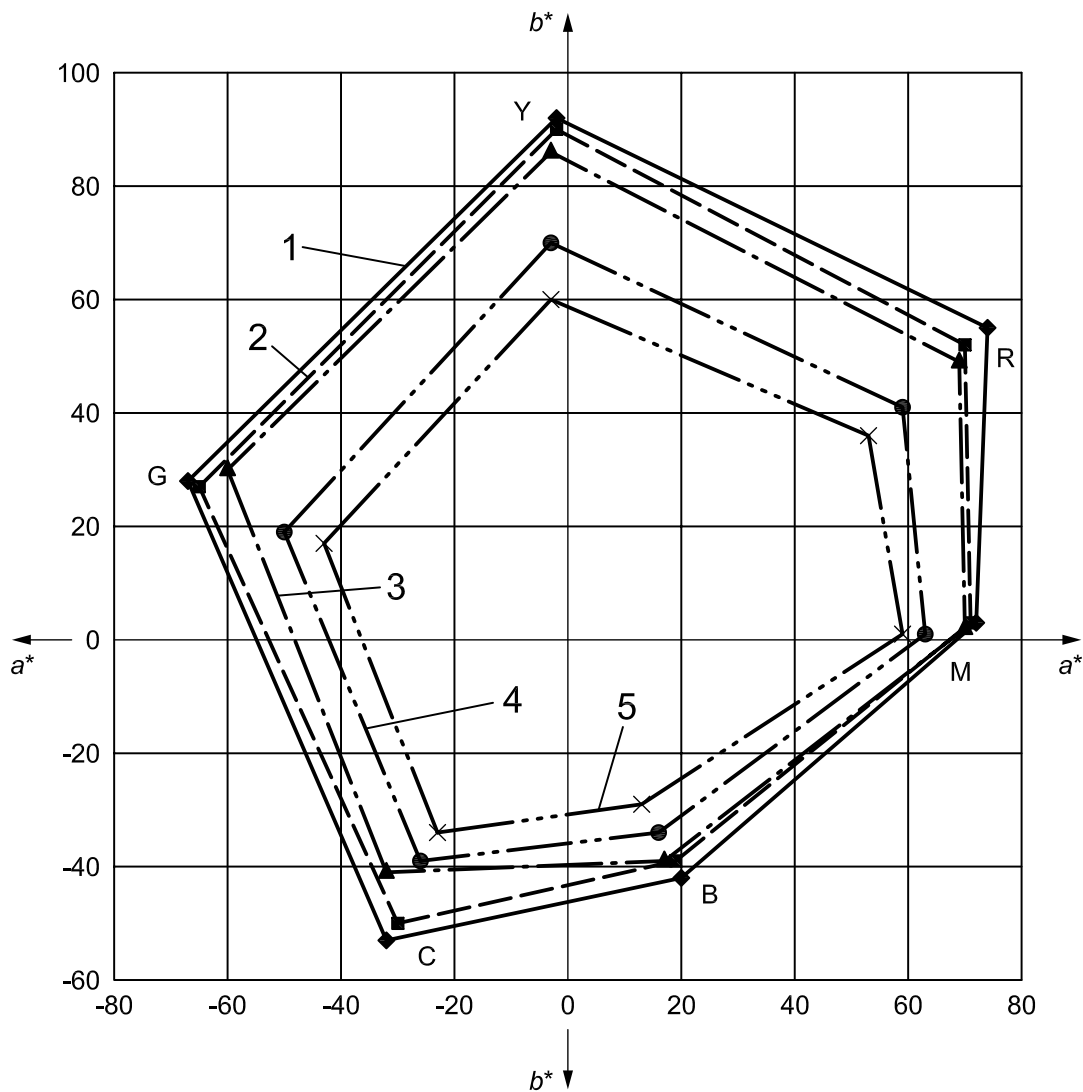

NOTE See [Table A.1](#) for values of a^* and b^* .

Figure A.1 — Gamut Type 1: CIELAB coordinates of solid colours (CMY, RGB) in [Table A.1](#)

A.3 Gamut Type 2

Table A.2 — CIELAB coordinates of print substrate, solid colours for Gamut Type 2

Unit: 1

Gamut Type 2		Print substrate														
		LWC plus			LWC standard			SC plus			SC standard			News plus		
Colour		Coordinates ^d			Coordinates ^d			Coordinates ^d			Coordinates ^d			Coordinates ^d		
		<i>L*</i>	<i>a*</i>	<i>b*</i>	<i>L*</i>	<i>a*</i>	<i>b*</i>	<i>L*</i>	<i>a*</i>	<i>b*</i>	<i>L*</i>	<i>a*</i>	<i>b*</i>	<i>L*</i>	<i>a*</i>	<i>b*</i>
Gamut Type 2		Printing condition ^a														
		S1a			S2a			S3a			S4a			S5a		
Colour		Coordinates ^b			Coordinates ^b			Coordinates ^b			Coordinates ^b			Coordinates ^b		
		<i>L*</i>	<i>a*</i>	<i>b*</i>	<i>L*</i>	<i>a*</i>	<i>b*</i>	<i>L*</i>	<i>a*</i>	<i>b*</i>	<i>L*</i>	<i>a*</i>	<i>b*</i>	<i>L*</i>	<i>a*</i>	<i>b*</i>
Black	WB	17	1	1	18	1	2	18	1	1	18	1	1	28	0	1
	BB	16	1	1	17	1	2	18	1	1	18	1	1	27	0	1
Cyan	WB	48	-25	-47	48	-28	-41	47	-27	-40	47	-27	-40	48	-19	-33
	BB	47	-25	-47	46	-27	-41	46	-26	-41	45	-26	-40	46	-19	-34
Magenta	WB	47	72	-8	46	68	-4	46	66	-5	46	66	-5	50	60	-3
	BB	46	71	-8	44	65	-5	45	64	-6	44	64	-6	48	58	-4
Yellow	WB	83	7	93	82	7	93	81	6	90	81	6	90	81	9	84
	BB	82	7	92	79	6	89	79	5	87	79	6	86	78	9	81
Red ^c	WB	45	69	52	44	66	50	44	64	47	44	64	47	48	61	38
	BB	44	68	51	42	63	47	43	62	45	42	62	45	46	59	36
Green ^c	WB	41	-48	31	40	-46	31	40	-44	28	40	-44	28	39	-32	20
	BB	41	-47	31	39	-45	29	39	-43	27	38	-42	27	37	-31	18
Blue ^c	WB	18	20	-48	19	16	-43	20	14	-41	20	14	-41	26	7	-35
	BB	18	20	-48	18	15	-42	19	13	-41	19	13	-40	25	7	-34
Overprint ^c	WB	14	-2	2	15	-1	2	15	-4	1	15	-4	1	23	-3	-2
	BB	14	-2	2	14	-1	2	15	-4	1	15	-3	1	22	-3	-3

NOTE 1 The secondary colours red, green, blue might vary depending on conditions that include the printing sequence, the surface characteristics of the print substrate, and the rheological and transparency properties of the inks. Thus, conformance of the primaries C, M, Y to this table is not sufficient for the conformance of the secondary colours to this table.

NOTE 2 WB: white backing/substrate backing values (normative); BB: black backing values (informative only).

^a Substrate categories according to 4.1 and Table 2.

^b Measurements to ISO 13655, (M0) with D50 illuminant, 2° observer, 0/45 or 45/0 geometry. Lower row values are measured over black. Upper row: measurement over white (self-backing).

^c Printing sequence: yellow, magenta, cyan; these values are informative only.

^d *L**, *a**, and *b** coordinates (BB and WB values) for print substrates see Table 2.

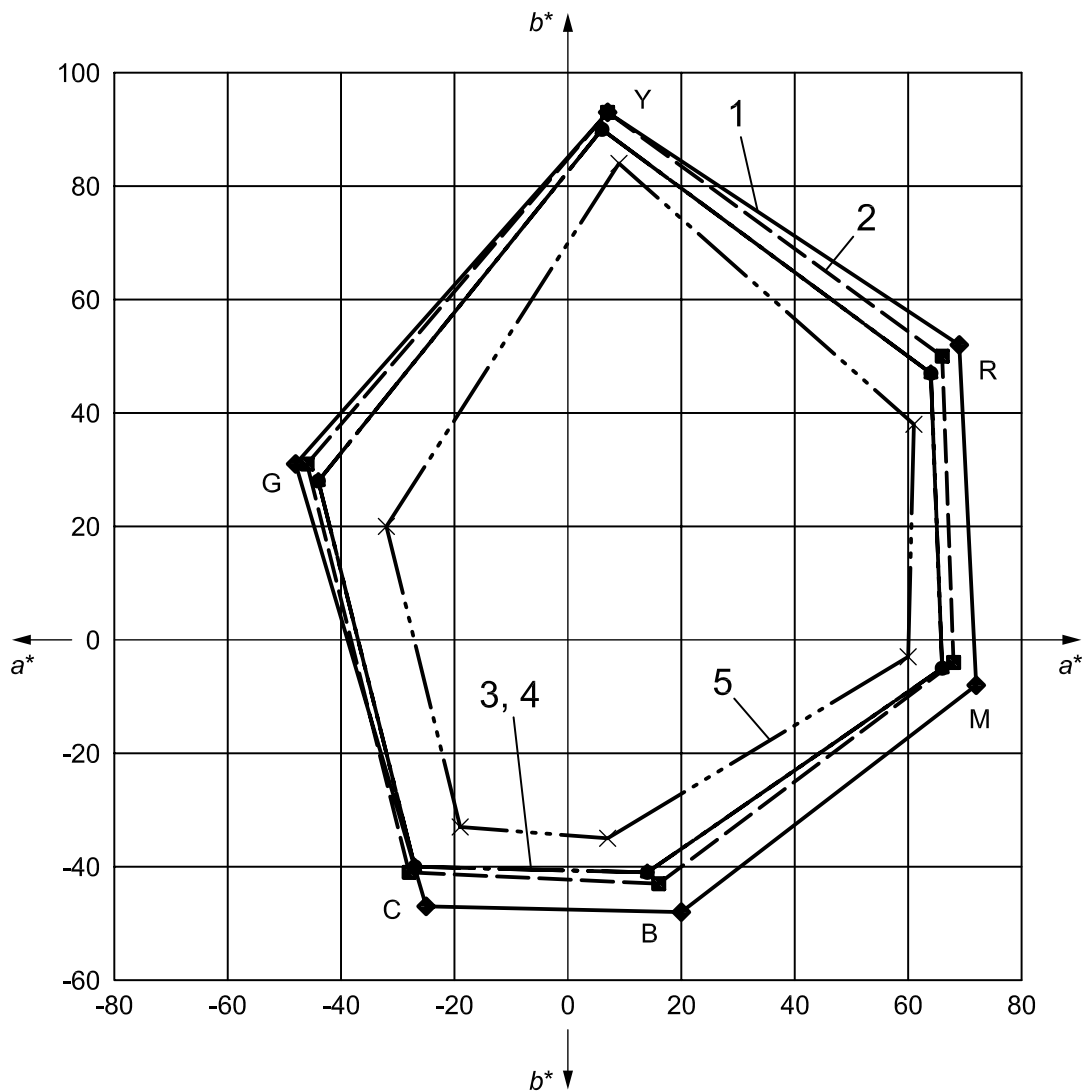

NOTE See [Table A.2](#) for values of a^* and b^* .

Figure A.2 — Gamut Type 2: CIELAB coordinates of solid colours (CMY, RGB) in [Table A.2](#)

Annex B (informative)

Grey reproduction and grey balance

The specification of a grey balance condition might be necessary if the aim values for the tone-value increase and the coloration of the tone values are not specified. With the aid of colour-management profiles that are based on a given printing condition and its characterization data set according to ISO 12642 -2, the grey balance conditions are accessible. A single grey balance condition is usually not sufficient to ensure an achromatic colour for all print substrates and printing inks that are used for a given printing condition. In addition, it usually depends on the particular black composition used.

On the other side, given a well characterized printing process based on well-defined aim values for the coloration of the solids, it can be useful to evaluate the grey balance of this process. Therefore a well proven condition of a grey reproduction might be necessary.

Earlier versions of this International Standard provide two practical definitions for grey: a colour having the same a^* and b^* CIELAB values as the print substrate and a colour having the same a^* and b^* CIELAB values as a half-tone tint of similar L^* value printed with black ink. The second definition is particularly useful in the mid-tone and shadow, whereas the first is best applied to highlight tones. So it seems useful to define a mixture of both or something similar for a single grey definition.

Most of the commonly used papers (substrates) in gravure publication printing contain very small or no levels of optical brightener agents (OBA). This fact results in yellowish CIELAB values of the paper white when using the colourimetry established for non-fluorescent samples while the visual appearance is nearly neutral for an observer. As a result, for substrates without any OBA, ISO 13655 M0 can be used but for substrates, like Gamut 1 S1, ISO 13655 M1 should be used.

The tone values of cyan, magenta, and yellow that lead to a visually neutral grey might be calculated from the standard printing condition or actual printing condition or the associated profiles by the following formula describing the grey reproduction (L^* , a^* , b^*) with respect to a given paper colour (L^*_{paper} , a^*_{paper} , b^*_{paper}) and CMY-overprint (L^*_{cmy}) for each L^* in the range from L^*_{paper} to L^*_{cmy} :

$$a^* = a^*_{\text{paper}} \times \left[1 - 0,85 \times \frac{(L^*_{\text{paper}} - L^*)}{(L^*_{\text{paper}} - L^*_{\text{cmy}})} \right] \quad (\text{B.1})$$

$$b^* = b^*_{\text{paper}} \times \left[1 - 0,85 \times \frac{(L^*_{\text{paper}} - L^*)}{(L^*_{\text{paper}} - L^*_{\text{cmy}})} \right] \quad (\text{B.2})$$

The multiplying factor of 0,85 represents a visual adaptation of 85 % to the paper white.

The proposed grey definition, a colour having a^* and b^* CIELAB values ranging from paper white a^* and b^* to less chromatic values for darker grey, is a good compromise between an easy implementation and a more complex colour appearance matching method. For any L^* between the paper white and the lowest achievable neutral L^* for a three-component grey, it is possible to calculate a^* and b^* values. [Figure B.1](#) shows the calculated a^* and b^* values from a typical print substrate with $a^* = 1$ and $b^* = 3$.

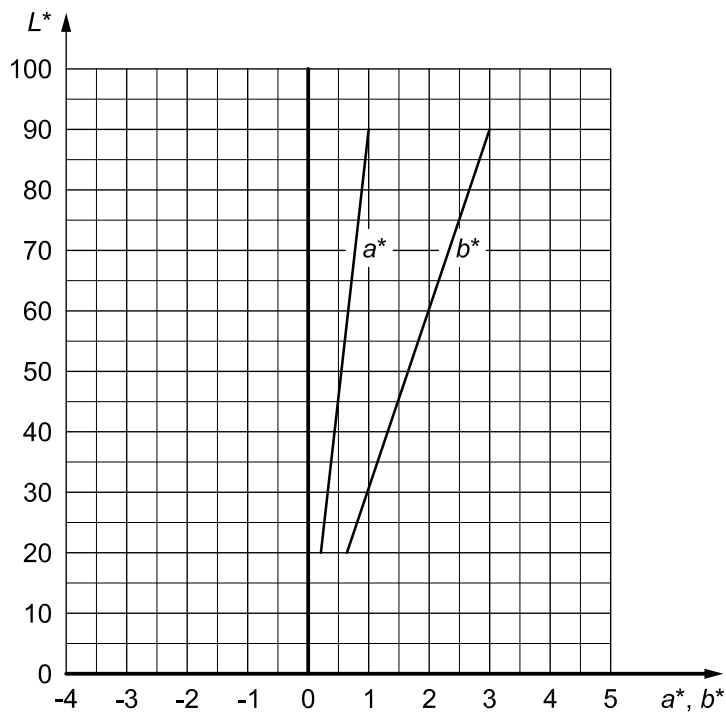

Figure B.1 — Example grey reproduction curve

The grey reproduction curve for a typical reference printing process on a coated paper is shown in [Figure B.1](#).

From a fully characterized printing process it is possible to calculate the corresponding grey balance values. The grey balance curve for a typical reference printing process on a coated paper is shown in [Figure B.2](#).

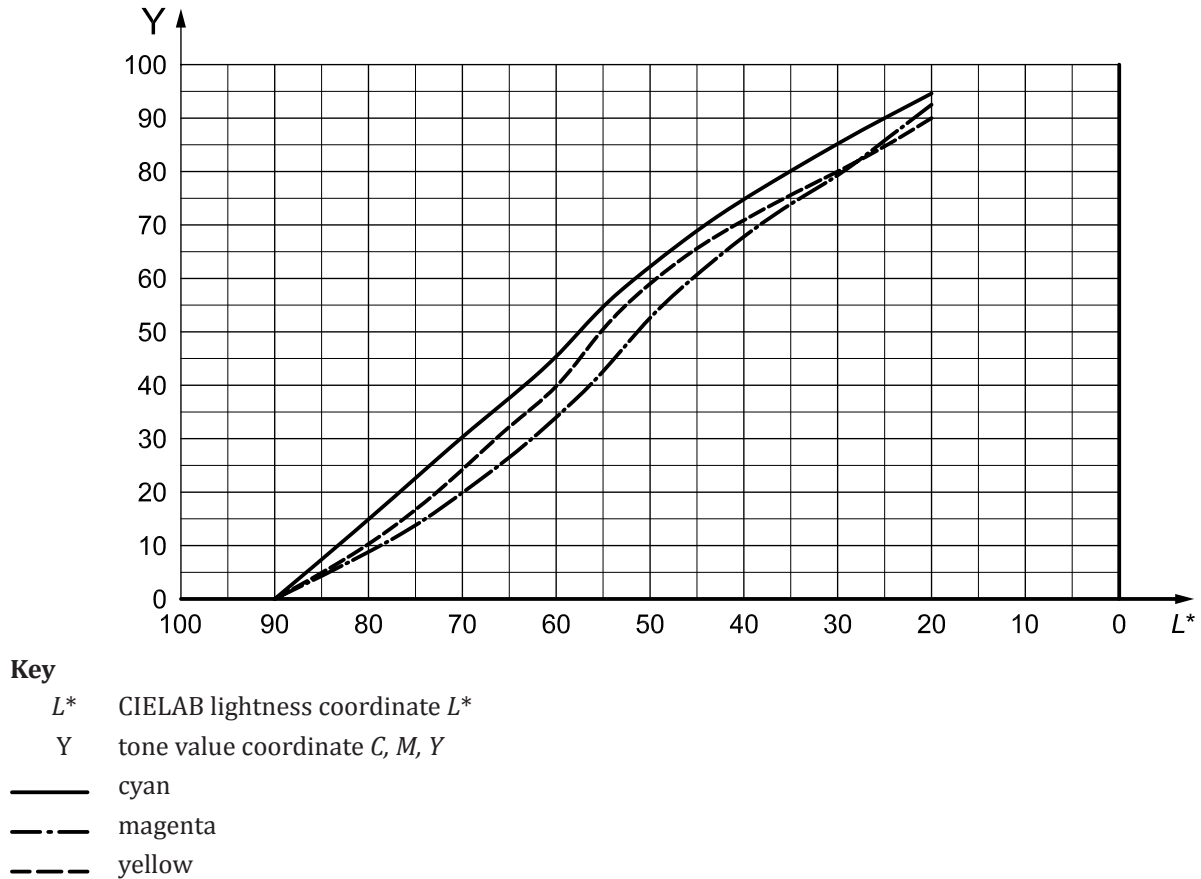

Figure B.2 — Example grey balance curve

From the grey balance curve, it is possible to calculate grey reproduction and grey balance values for process calibration and process control purposes.

Deviation values for grey reproduction can be calculated from a characterized printing process and a production print by introducing a chroma difference, ΔCh^* , between the desired grey reproduction chroma and the measured chroma of a grey balance control patch:

$$\Delta Ch^* = \left[(a^*_{1} - a^*_{2}) \times (a^*_{1} - a^*_{2}) + (b^*_{1} - b^*_{2}) \times (b^*_{1} - b^*_{2}) \right]^{1/2} \quad (B.3)$$

Table B.1 — Example grey balance and grey reproduction values

Grey balance			
	%	%	%
C	25,0	50,0	75,0
M	15,7	38,3	68,0
Y	19,0	45,1	71,1
Grey reproduction			
	1	1	1
L*	73,4	57,4	39,8
a*	0,8	0,6	0,4
b*	2,4	1,9	1,3
Tolerance			
	1	1	1
ΔCh^*	2	2	2

It should be noted that the tolerance values for highlight, mid-tone and shadow depend on the printing process and the lightness of the cyan, magenta, and yellow overprint and should be defined for every printing condition separately.

For printing conditions as described in this part of ISO 12647, it is recommended to create standard characterization data sets. From these data sets grey balance and grey reproduction data and special control aids as well as profiles for colour separation can be derived. Printing on production papers with different paper whites need slightly modified grey reproduction values. This modification can be done with the linear scaling method as described in ISO 13655:2009, Annex A.4.

Bibliography

- [1] ISO 2846-3, *Graphic technology — Colour and transparency of printing ink sets for four-colour printing — Part 3: Publication gravure printing*
- [2] ISO 8791-4, *Paper and board — Determination of roughness/smoothness (air leak methods) — Part 4: Print-surf method*
- [3] ISO 12639, *Graphic technology — Prepress digital data exchange — Tag image file format for image technology (TIFF/IT)*
- [4] ISO 12647-2, *Graphic technology — Process control for the production of half-tone colour separations, proof and production prints — Part 2: Offset lithographic processes*
- [5] ISO 14981, *Graphic technology — Process control — Optical, geometrical and metrological requirements for reflection densitometers for graphic arts use*
- [6] ISO 15076-1, *Image technology colour management — Architecture, profile format and data structure — Part 1: Based on ICC.1:2010*

Research or trade organization that publishes fully characterized printing conditions:

- [7] ECI, EUROPEAN COLOR INITIATIVE. www.eci.org
- [8] FOGRA, GRAPHIC TECHNOLOGY RESEARCH ASSOCIATION. www.fogra.org
- [9] IDEALLIANCE, INTERNATIONAL DIGITAL ENTERPRISE ALLIANCE. www.idealliance.org
- [10] WAN-IFRA, WORLD ASSOCIATION OF NEWSPAPERS AND NEWS PUBLISHERS. www.wan-ifra.org
- [11] ICC, INTERNATIONAL COLOR CONSORTIUM. www.color.org

