**Graphic technology — Safety
requirements for graphic technology
equipment and systems —**

Part 4:
Converting equipment and systems

*Technologie graphique — Exigences de sécurité pour les systèmes et
l'équipement de technologie graphique —*

Partie 4: Systèmes et équipement de façonnage



PDF disclaimer

This PDF file may contain embedded typefaces. In accordance with Adobe's licensing policy, this file may be printed or viewed but shall not be edited unless the typefaces which are embedded are licensed to and installed on the computer performing the editing. In downloading this file, parties accept therein the responsibility of not infringing Adobe's licensing policy. The ISO Central Secretariat accepts no liability in this area.

Adobe is a trademark of Adobe Systems Incorporated.

Details of the software products used to create this PDF file can be found in the General Info relative to the file; the PDF-creation parameters were optimized for printing. Every care has been taken to ensure that the file is suitable for use by ISO member bodies. In the unlikely event that a problem relating to it is found, please inform the Central Secretariat at the address given below.



COPYRIGHT PROTECTED DOCUMENT

© ISO 2010

All rights reserved. Unless otherwise specified, no part of this publication may be reproduced or utilized in any form or by any means, electronic or mechanical, including photocopying and microfilm, without permission in writing from either ISO at the address below or ISO's member body in the country of the requester.

ISO copyright office
Case postale 56 • CH-1211 Geneva 20
Tel. + 41 22 749 01 11
Fax + 41 22 749 09 47
E-mail copyright@iso.org
Web www.iso.org

Published in Switzerland

Contents

Page

Foreword	v
Introduction.....	vi
1 Scope	1
2 Normative references	1
3 Terms and definitions	2
4 Equipment covered by this part of ISO 12643	2
4.1 General	2
4.2 Machines used primarily in a converting operation	2
4.3 Machines used in both printing and converting processes	2
5 Machinery for the production of corrugated board	3
5.1 All machines	3
5.2 Unwinding stations	4
5.3 Splicers.....	6
5.4 Preheater	7
5.5 Single facer	9
5.6 Inclined belt conveyor.....	14
5.7 Bridge	14
5.8 Braking and web aligning section	15
5.9 Gluing machine.....	15
5.10 Heating and pulling section.....	16
5.11 Rotary shear unit	18
5.12 Pulling unit	18
5.13 Slitter-scorer units.....	19
5.14 Web diverter	20
5.15 Sheeters.....	20
5.16 Stacker devices	21
6 Folding box gluer machines.....	25
6.1 Entire machine.....	25
6.2 Feeder.....	25
6.3 Folding section	25
6.4 Gluing section.....	27
6.5 Folding belt	27
6.6 Pressing section.....	28
7 Pre-feeders	29
7.1 Pre-feeder with pile carrier plate.....	29
7.2 Pre-feeder with pile turner	30
8 In-line machines	32
8.1 Entire machine.....	32
8.2 Feeding unit	33
8.3 Printing unit	35
8.4 Slitter-scorer unit, rotary die-cutter	36
8.5 Folding unit (folding box gluer)	36
8.6 Taping unit	37
8.7 Stitching unit.....	37
9 Automatic flatbed die-cutting machines	38
9.1 Entire machine.....	38
9.2 Feeder	39

9.3	Punching section	39
9.4	Stripping section.....	40
9.5	Blank separating section, blank delivery	40
9.6	Trimming and delivery of gripper edge	40
10	Roller press die-cutters.....	40
11	Tube winding machines	40
11.1	Ply reels	40
11.2	In-running nips on shaft bearings.....	40
11.3	In-running nip between winding belt and winding material	40
11.4	In-running nips.....	42
11.5	In-running nips between glue rollers.....	42
11.6	Tube cutting and sawing section	42
11.7	Tube transfer	42
12	Machinery for the production of envelopes	42
12.1	Printing unit guarding	42
12.2	Longitudinal and cross-scoring section	43
12.3	Form cutting section	43
12.4	Driven guide rollers	43
12.5	Window cutting section	43
12.6	Window material conveying section with unwinding unit.....	43
12.7	Scraper gluing unit	44
12.8	Separating cutting section.....	44
12.9	Bottom flap folding section	44
12.10	Transport rolls.....	45
12.11	Staggering wheel	45
12.12	Roller gluing unit	45
12.13	Hot air dryers.....	47
12.14	Separation roller before aligner section.....	47
12.15	Aligner section	47
12.16	Seal flap folding section	47
12.17	Separating disc delivery	48
12.18	Starting the machine with interlocking guards open	48
13	Instruction handbook	48
13.1	Corrugated board machinery	48
13.2	Machines for the production of envelopes	49
	Bibliography	51

Foreword

ISO (the International Organization for Standardization) is a worldwide federation of national standards bodies (ISO member bodies). The work of preparing International Standards is normally carried out through ISO technical committees. Each member body interested in a subject for which a technical committee has been established has the right to be represented on that committee. International organizations, governmental and non-governmental, in liaison with ISO, also take part in the work. ISO collaborates closely with the International Electrotechnical Commission (IEC) on all matters of electrotechnical standardization.

International Standards are drafted in accordance with the rules given in the ISO/IEC Directives, Part 2.

The main task of technical committees is to prepare International Standards. Draft International Standards adopted by the technical committees are circulated to the member bodies for voting. Publication as an International Standard requires approval by at least 75 % of the member bodies casting a vote.

Attention is drawn to the possibility that some of the elements of this document may be the subject of patent rights. ISO shall not be held responsible for identifying any or all such patent rights.

ISO 12643-4 was prepared by Technical Committee ISO/TC 130, *Graphic technology*.

It is the intent of ISO/TC 130 that this first edition of ISO 12643-4 become applicable to new equipment manufactured from 2011-01-01.

ISO 12643 consists of the following parts, under the general title *Graphic technology — Safety requirements for graphic technology equipment and systems*:

- *Part 1: General requirements*
- *Part 2: Prepress and press equipment and systems*
- *Part 3: Binding and finishing equipment and systems*
- *Part 4: Converting equipment and systems*
- *Part 5: Stand-alone platen presses*

Introduction

The purpose of this part of ISO 12643 is to reduce the risk of injury to operating personnel working on converting equipment.

This part of ISO 12643 provides requirements for the design and construction of converting equipment used in the package printing, converting and graphic technology industries. It covers equipment not addressed by the other parts of ISO 12643. It is intended to be used in conjunction with ISO 12643-1 and provides additional requirements that are specific to converting equipment.

During the development of this part of ISO 12643, existing relevant standards of other countries were taken into consideration. An effort has been made to take into consideration the requirements of many countries, recognizing that national standards or laws may dictate national requirements. Cases where a national requirement was known to differ from this part of ISO 12643 have been noted.

This part of ISO 12643 was developed to harmonize the following US and European safety standards:

ANSI/PMMA B155.1, *Safety Requirements for Packaging Machinery and Packaging-Related Converting Machinery*

EN 1010-4, *Safety of machinery — Safety requirements for the design and construction of printing and paper converting machines — Part 4: Bookbinding, paper converting and finishing machines*

EN 1010-5, *Safety of machinery — Safety requirements for the design and construction of printing and paper converting machines — Part 5: Machines for the production of corrugated board and machines for the conversion of flat and corrugated board*

Graphic technology — Safety requirements for graphic technology equipment and systems —

Part 4: Converting equipment and systems

1 Scope

This part of ISO 12643 provides safety requirements for the design and construction of converting equipment used in the package printing, converting and graphic technology industries. It is applicable to converting equipment not covered by other parts of ISO 12643. It is intended to be used in conjunction with the general requirements given in ISO 12643-1.

2 Normative references

The following referenced documents are indispensable for the application of this document. For dated references, only the edition cited applies. For undated references, the latest edition of the referenced document (including any amendments) applies.

ISO 12643-1, *Graphic technology — Safety requirements for graphic technology equipment and systems — Part 1: General requirements*

ISO 13732-1, *Ergonomics of the thermal environment — Methods for the assessment of human responses to contact with surfaces — Part 1: Hot surfaces*

ISO 13849-1, *Safety of machinery — Safety-related parts of control systems — Part 1: General principles for design*

ISO 13850, *Safety of machinery — Emergency stop — Principles for design*

ISO 13855, *Safety of machinery — Positioning of protective equipment with respect to the approach speeds of parts of the human body*

ISO 13857, *Safety of machinery — Safety distances to prevent hazard zones being reached by upper and lower limbs*

ISO 14119, *Safety of machinery — Interlocking devices associated with guards — Principles for design and selection*

ISO 14122-3, *Safety of machinery — Permanent means of access to machinery — Part 3: Stairs, stepladders and guard-rails*

IEC 60529, *Degrees of protection provided by enclosures (IP code)*

IEC 62061, *Safety of machinery — Functional safety of safety-related electrical, electronic and programmable electronic control systems*

EN 619, *Continuous handling equipment and systems — Safety and EMC requirements for equipment for mechanical handling of unit loads*

3 Terms and definitions

For the purposes of this document, the terms and definitions given in ISO 12643-1 apply.

4 Equipment covered by this part of ISO 12643

4.1 General

This part of ISO 12643 covers a variety of equipment used in printing plants and converting operations. Those used primarily in a converting operation are listed in 4.2, while those that may be used in a printing operation covered in other parts of ISO 12643 are listed in 4.3.

4.2 Machines used primarily in a converting operation

Machines used primarily in a converting operation include the following:

- machinery for the production of envelopes;
- machinery for the production of corrugated board;
- folding-box gluer machines;
- in-line machines;
- automatic flatbed punching machines;
- tube-winding machines;
- box-making machines;
- finishing/window equipment;
- hole punching machines;
- laminating machines/laminators;
- pre-feeding/stack-turning machines.

4.3 Machines used in both printing and converting processes

Machines used in both printing and converting processes include the following:

- label printing machines (see also ISO 12643-1 and ISO 12643-2);
- coating machines (see also ISO 12643-3);
- curing and drying machines (see also ISO 12643-2);
- cutters, creasers and die-cutters (see also ISO 12643-3);
- rewinding/roll equipment/slitting and rewinding equipment (see also ISO 12643-1);
- embossing equipment (see also ISO 12643-2 and ISO 12643-5);
- tension control equipment (see also ISO 12643-1).

5 Machinery for the production of corrugated board

5.1 All machines

5.1.1 General

An example of a corrugating machine is shown in Figure 1.

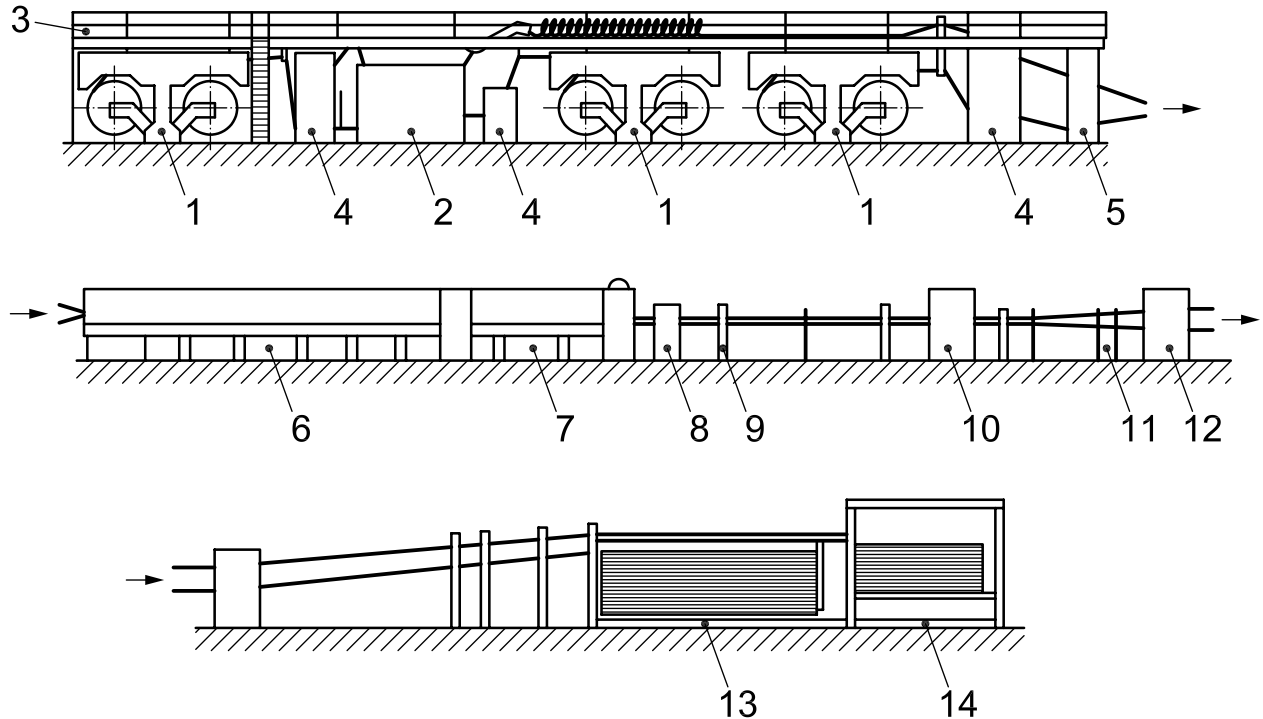

Key

1	unwind	6	heating section	11	web diverter
2	single facer	7	pulling section	12	sheeter
3	bridge	8	rotary shears	13	upstacker
4	preheater	9	pulling unit	14	downstacker
5	gluing machine	10	slitter-scorer unit		

Figure 1 — Principle of a machine for the production of corrugated board

5.1.2 Emergency stop

Emergency stop devices shall be provided on each motion control station. Emergency stop devices shall be no more than 15 m apart.

Emergency stop devices shall stop the motion of the entire machine.

EXCEPTION — The glue rollers of the gluing unit may continue running if the danger points on the gluing unit are safeguarded by guards.

5.1.3 Zone control with stop/safe devices

Where stop/safe devices are provided, the following requirements apply:

- stop/safe actuators shall be marked such that they clearly indicate the section to which they apply;
- signal processing shall comply with $PL_r d$ of ISO 13849-1 or SIL 2 of IEC 62061.

Where the machine is configured into control zones, they shall be as follows (see Figure 2):

- a) one control zone for each single-facer group (unwind of liner with preheater, single facer, unwind of corrugated web);
- b) one control zone for the liner unwind before heating up to stacker device.

One or more stop/safe devices shall be provided in each control zone.

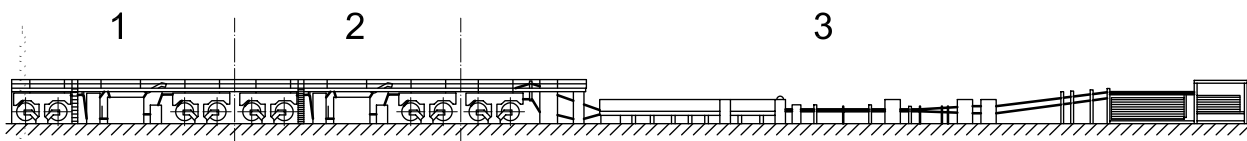

Key

- 1 first control zone for first single-facer group
- 2 second control zone for second single-facer group
- 3 third control zone for liner unwind up to stacker device

Figure 2 — Control zones

5.1.4 Access stairs and walkways

Access stairs and walkways shall comply with ISO 12643-1.

5.1.5 Steam pipes

Steam pipes that can be accessed from any working level shall be insulated up to a height of 2,70 m from the working level for protection against burning.

5.1.6 Guarding access points between system components

Accessible areas between system components shall be guarded by means of fixed or interlocking guards in accordance with ISO 12643-1 if a hazard point can be reached, e.g. the area between a gluing machine and a heating and pulling section.

5.1.7 Audible start-up warning

Corrugating machines shall have an audible warning system that complies with ISO 12643-1.

5.2 Unwinding stations

5.2.1 General

Means shall be provided to ensure that reel cores, which might be stuck to a reel cone, can be safely removed, e.g. using an automatic reel core ejector that pushes the core away from the cone.

5.2.2 Safeguarding automatic reel loading

The area where automatic reel loading takes place shall be safeguarded in accordance with ISO 12643-1.

See Figure 3 for an illustration of the positioning of electro-sensitive protective devices (ESPDs) for this equipment in accordance with the requirements of ISO 12643-1.

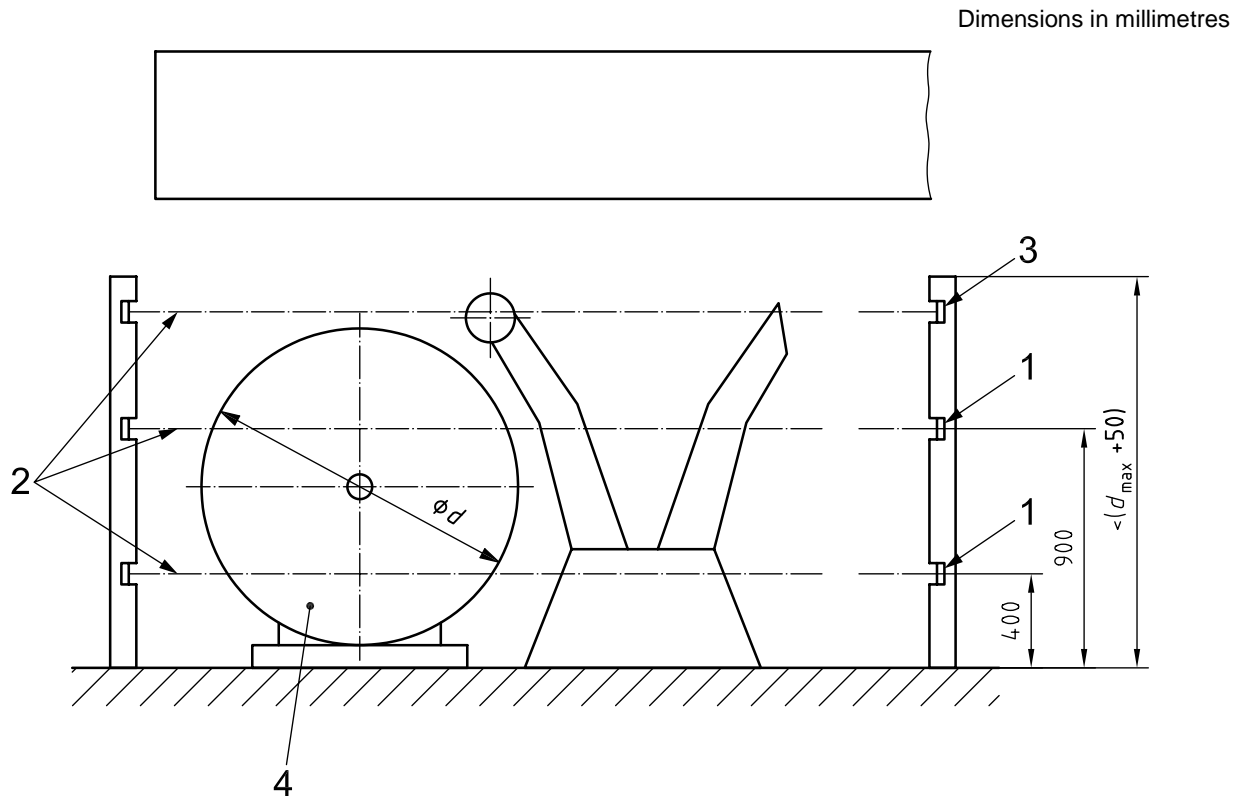

Key

- 1 ESPD
- 2 photoelectric beam of the ESPD
- 3 additional ESPD
- 4 material reel

Figure 3 — Unwinding station, automatic reel loading

5.2.3 Chucking cones and lifting arms

The hold-to-run speeds for inserting the chucking cones and moving the lifting arms may be increased to 15 m/min maximum if the hold-to-run buttons are located at a minimum distance of 850 mm from the lifting arms.

5.2.4 Braking systems

The blowers for the braking systems on unwinding stations shall have at least the degree of protection IP 23, as specified in IEC 60529. Accumulation of inflammable dust in the brakes shall be prevented.

NOTE The accumulation of inflammable dust in the brakes can be reduced if the louvres provided in the ventilator housing open to the bottom while the lifting arms are in operating position.

5.3 Splicers

5.3.1 Guarding hazard points

On splicers, any hazard points between the dancer roller carriage and guide rollers, and between the dancer roller and fixed parts of the machine shall be avoided by design measures or be safeguarded (see Figure 4).

If safeguarding by distance, the following requirements apply:

- a minimum distance of 25 mm if the hazard points are at a height greater than 2,20 m;
- a minimum distance of 120 mm if the hazard points are at a height less than or equal to 2,20 m.

Safeguarding may also be achieved by the use of guards in accordance with ISO 12643-1 or safety devices with approach reaction (e.g. trip devices, pressure-sensitive mats, electro-sensitive devices).

5.3.2 Dancer roller

The movement of the dancer roller into position for web threading shall be safeguarded.

Where hold-to-run control is used for safeguarding, the hold-to-run speed shall not exceed 15 m/min.

The in-running nips on the dancer roll carriage wheels shall be safeguarded by fixed guards that meet the requirements of ISO 12643-1.

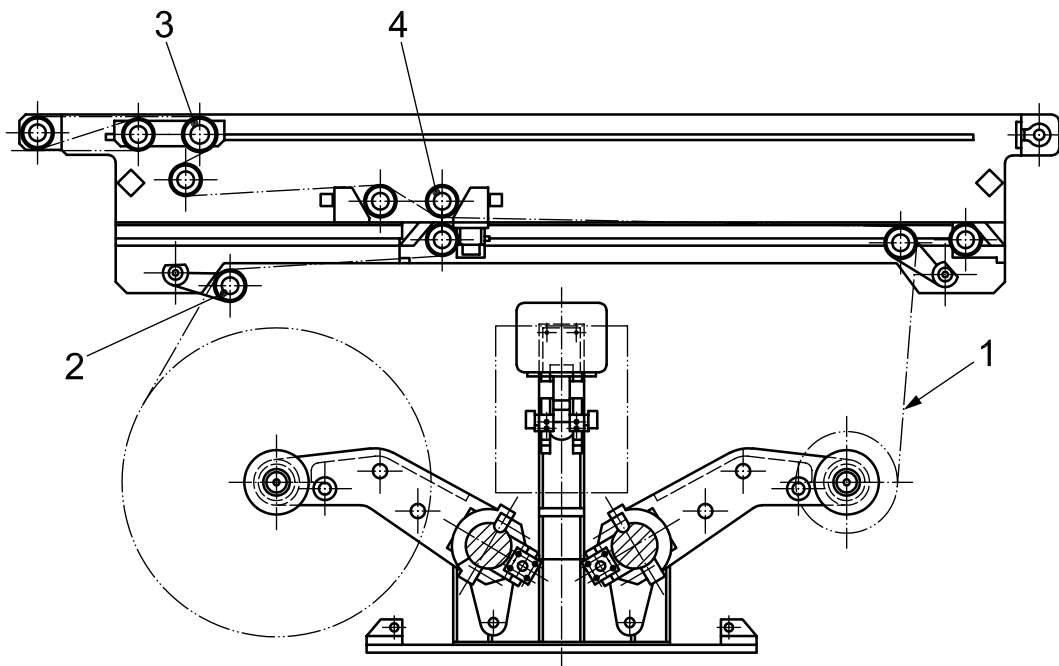

Key

- 1 paper web
- 2 guide rollers
- 3 dancer roller
- 4 gluing unit

Figure 4 — Splicer

5.3.3 Splicers

On splicers, hazard points between the movable suction bar and fixed machine parts shall be prevented by safety measures or be safeguarded (see Figure 4). Safeguarding can be achieved by one or more of the following measures:

- providing a minimum distance of 25 mm for danger points above 2,20 m and of 120 mm for heights less than or equal to 2,20 m;
- a hold-to-run control meeting the requirements of ISO 12643-1, if it is possible to observe the hazard points and hazard zones from the point of operation of the hold-to-run control;
- limiting the force of the movable glue bar to 300 N and the travel speed of the carriage to 15 m/min.

The control panel for operating the glue bar shall be provided with an emergency stop button.

5.3.4 Knife

The cutting edge of the knife shall be safeguarded in the rest position.

5.3.5 Pneumatic and hydraulic control systems

Where pneumatic or hydraulic control systems are used for starting the cutting cycle, a safety-rated check valve shall be supplied to ensure that the knife remains in the safe position in case of leakage or hose breakage.

5.3.6 Frame edges

Where the machine frame of the splicer is lower than 2 m at the sides (as measured from the floor), frame edges shall be provided with black-yellow padding for protection against impacts.

5.3.7 Splicers in elevated positions

If preparation of the movable suction bar cannot be accomplished from floor level, safe access shall be provided.

5.3.8 Warning lights

A red warning light shall flash for 2 s prior to the initiation of the automatic splicing operation and during the entire period of automatic motion. The integration of the status lights into the control system may be single-channel, e.g. via an electronic control system.

5.4 Preheater

5.4.1 In-running nips

The in-running nips between the wrap roller and the preheating cylinder, and between the wrap roller and fixed machine parts or guide rollers (see Figure 5), shall be safeguarded by one or more of the following measures:

- using the minimum distance of 120 mm;
- guarding in accordance with ISO 12643-1.

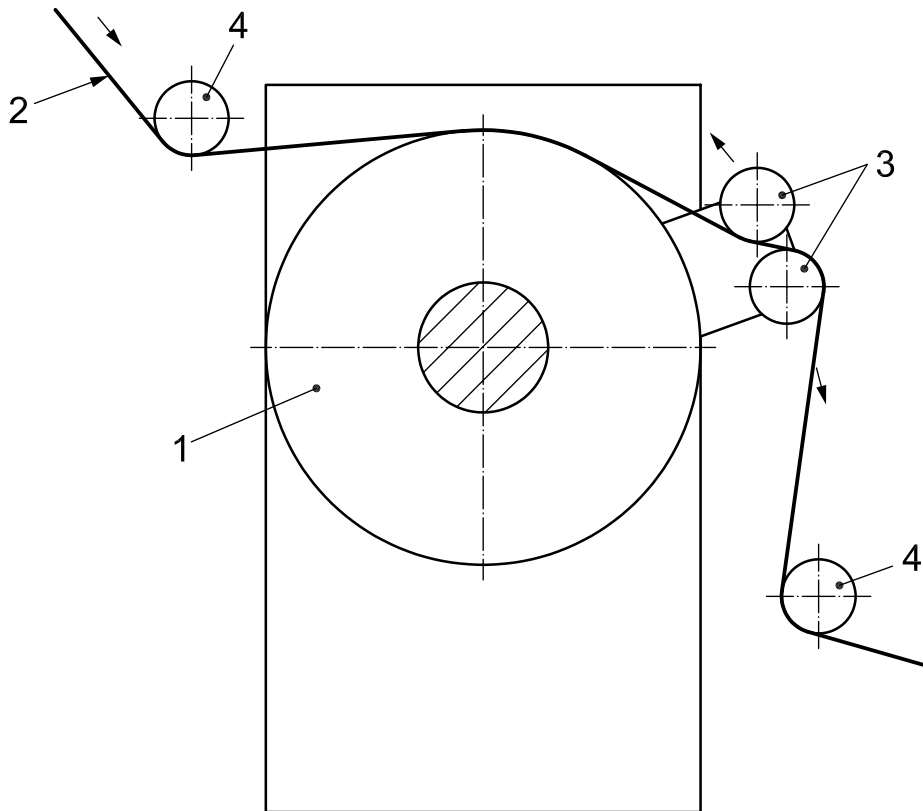

Key

- 1 preheating cylinder
- 2 paper web
- 3 wrap roller
- 4 guide roller

Figure 5 — Preheater, side view

5.4.2 In-running nips between preheating cylinder and cross beams

The in-running nips between the preheating cylinder and any cross beam shall be safeguarded by maintaining a minimum distance of 300 mm.

5.4.3 Wrap roller and wrap arms

The drives for the wrap roller shall be safeguarded by fixed guards completely enclosing the drives.

Rotating wrap arms (see Figure 6, item 2) shall be designed such that any openings in the wrap arms do not create a shearing hazard.

The distance (see Figure 6, *d*) between the preheating cylinder and the rotating arm shall be 6 mm or less or 30 mm or more.

The hazard point between the rotating arms and the machine side frame shall be safeguarded (see Figure 6, items 2 and 4) by one or both of the following measures:

- a hold-to-run control of at least PL_r c of ISO 13849-1 or SIL 1 of IEC 62061 as specified in ISO 13849-1;
- a minimum distance of 120 mm and designing the rotating arm or machine side in such a way that parts of the body are deflected by the arm when rotating at its maximum circumferential speed of 5 m/min.

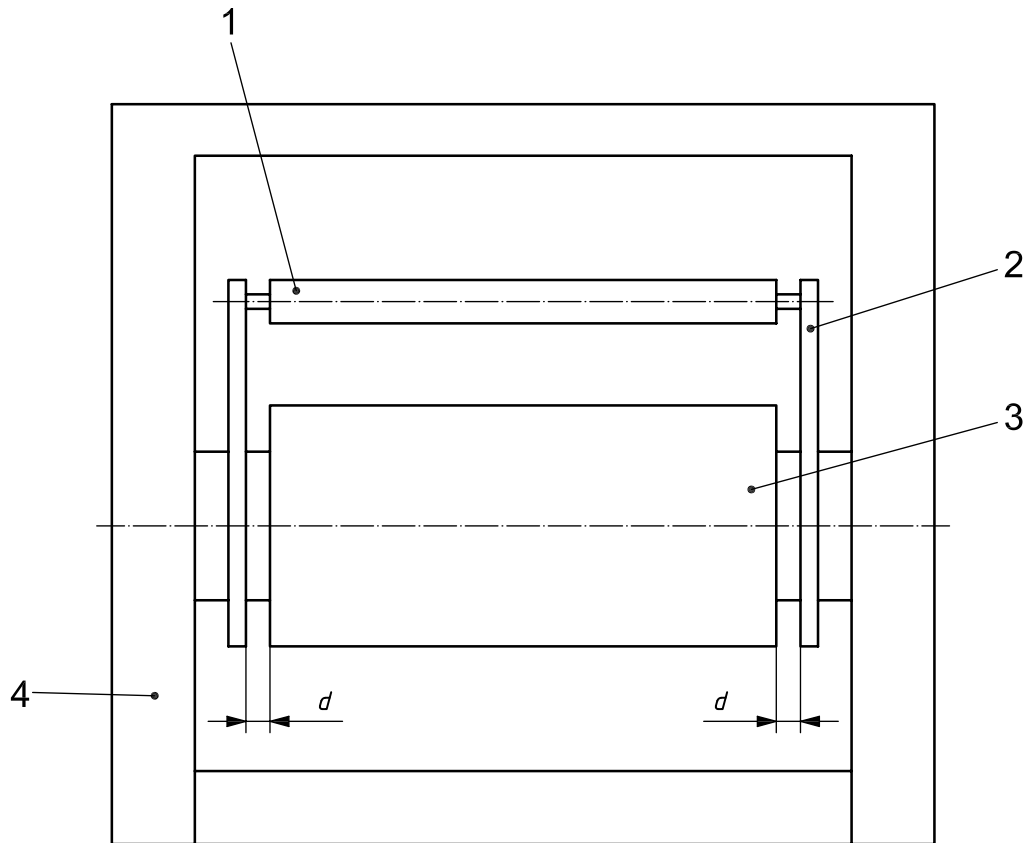
**Key**

- 1 wrap roller
- 2 rotating arm
- 3 preheating cylinder
- 4 machine frame
- d* distance between preheating cylinder and rotating arm

Figure 6 — Preheater, feeding side**5.4.4 Hot surfaces**

As the temperature of preheating cylinders may be higher than 65 °C, warning signs indicating the hot surfaces shall be fitted to both sides of the preheater. Operators working near the preheater shall wear appropriate personal protection equipment to protect against burns.

5.4.5 Walkways

If walkways with fall-off protection are located near preheaters, the distance between the fall-off protection and movable parts of the preheater shall be at least 120 mm.

For fall-off protection and walkways, see ISO 12643-1.

5.5 Single facer**5.5.1 In-running nips**

On single facers where the web is fed through a webbing slot, if it is impossible to apply the safety distances specified in ISO 13857 (as required by ISO 12643-1), a safety distance of 300 mm shall be observed for gaps with a width of more than 20 mm and less than or equal to 40 mm.

The in-running nips between the corrugating rollers and fixed machine parts shall be safeguarded by fixed guards. The hazard point between the corrugating roller and the cross beam with scrapers is considered to be safeguarded if the clearance between the corrugating roller and the cross beam is at least 25 mm and the clearance between the scrapers is no more than 60 mm (see Figure 7).

Dimensions in millimetres

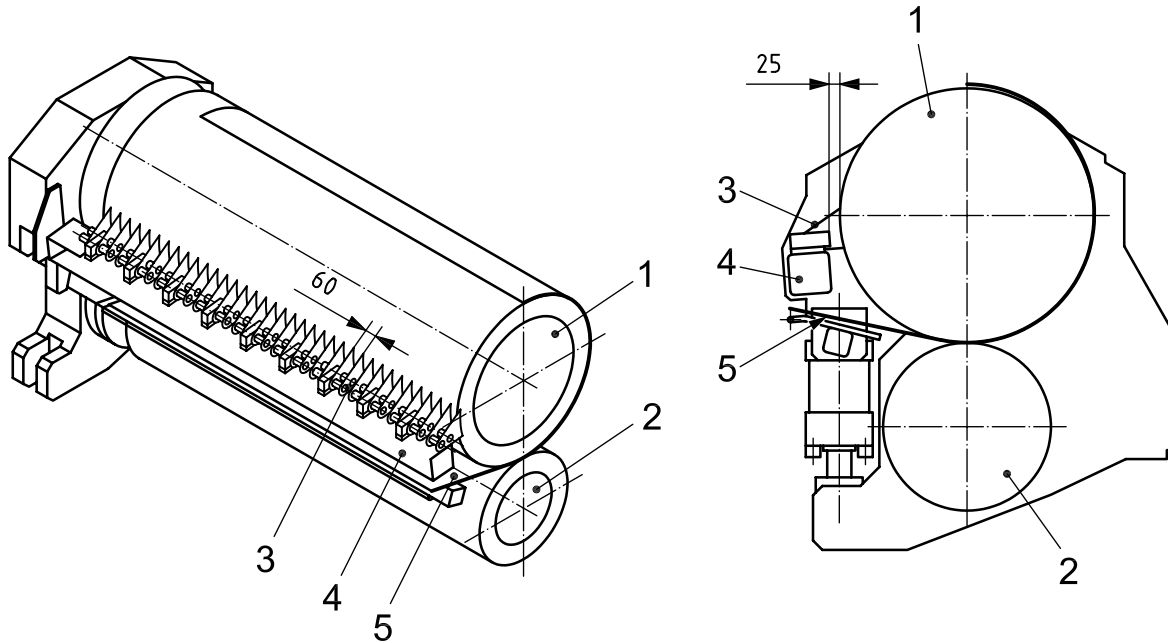

Key

- 1 upper corrugating roller
- 2 lower corrugating roller
- 3 scraper
- 4 cross beam
- 5 feeding of paper web

Figure 7 — Corrugating rollers with scraper (front and side views)

5.5.2 Corrugating rollers

Where corrugating rollers are removed for changing, means of transport shall be provided that allow easy and safe changing of rollers.

When noise enclosures are used, they shall be designed in such a way that loading and unloading of the corrugating rollers is not impeded.

5.5.3 Hazard points during roller change

Any hazard points that can be accessed after removal of, or during changing of, corrugating rollers shall be safeguarded in accordance with ISO 12643-1.

Where corrugating rollers are mounted on an indexing turret, any movement of the turret shall be under hold-to-run control with displacement limited to a maximum of 75 mm or with a maximum operating speed of 5 m/min.

5.5.4 In-running nip between pressure roller or pressing belt and corrugating roller

The in-running nip between the pressure roller or pressing belt and the corrugating roller (see Figure 8) shall be safeguarded by fixed guards.

The crushing point created by the lowering of the pressure roller contacting the corrugating roller shall be safeguarded by a guard in accordance with ISO 12643-1 or by using a horizontal safety distance of 1 000 mm from the hazard point (see Figure 8).

In-running nips on the pressing belt shall be safeguarded by fixed guards.

5.5.5 Belt breakage

On the delivery side of the single-faced corrugated web (inclined belt conveyor side), a containment device shall be provided to eliminate the risk of injury in the case of belt breakage.

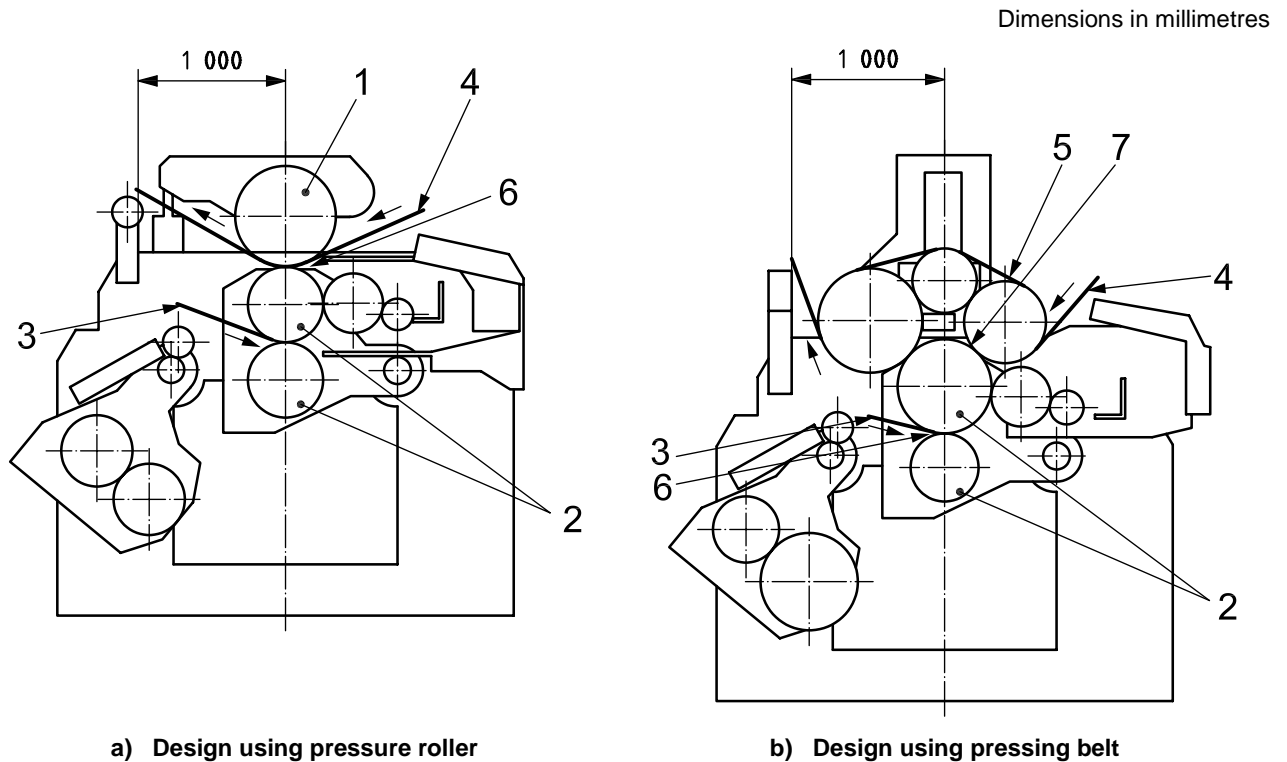

Key

1	pressure roller	5	pressing belt
2	corrugating rollers	6	in-running nip
3	corrugated web	7	in-running nip on pressing belt
4	liner		

Figure 8 — Corrugating unit

5.5.6 Walkway

The walkway on the inclined belt conveyor side (see Figure 9, item 7) shall have fall-off protection towards the corrugating rollers. Cross beams provided for fall-off protection shall be at a height of 1,10 m (see Figure 9, item 6). Intermediate rails or toe boards are not required.

5.5.7 In-running nips between glue rollers

In-running nips between glue rollers or between glue rollers and corrugating rollers that are accessible when the gluing unit is lowered shall be safeguarded by fixed guards in accordance with ISO 12643-1.

Where lowering and raising the gluing unit is an automatic operation, the gluing unit shall not create any hazard points; otherwise, this movement shall only be carried out under hold-to-run control at a maximum speed of 5 m/min.

Where maintenance or cleaning operations are carried out with the interlocking guard covering the gluing unit in an open position (see Figure 10), the glue rollers (applicator, scraper roll) shall only be allowed to rotate at a maximum circumferential speed of 6 m/min. Glue rollers shall rotate in the same direction with no possibility of access to an in-running nip between corrugating roller and glue roller.

Dimensions in millimetres

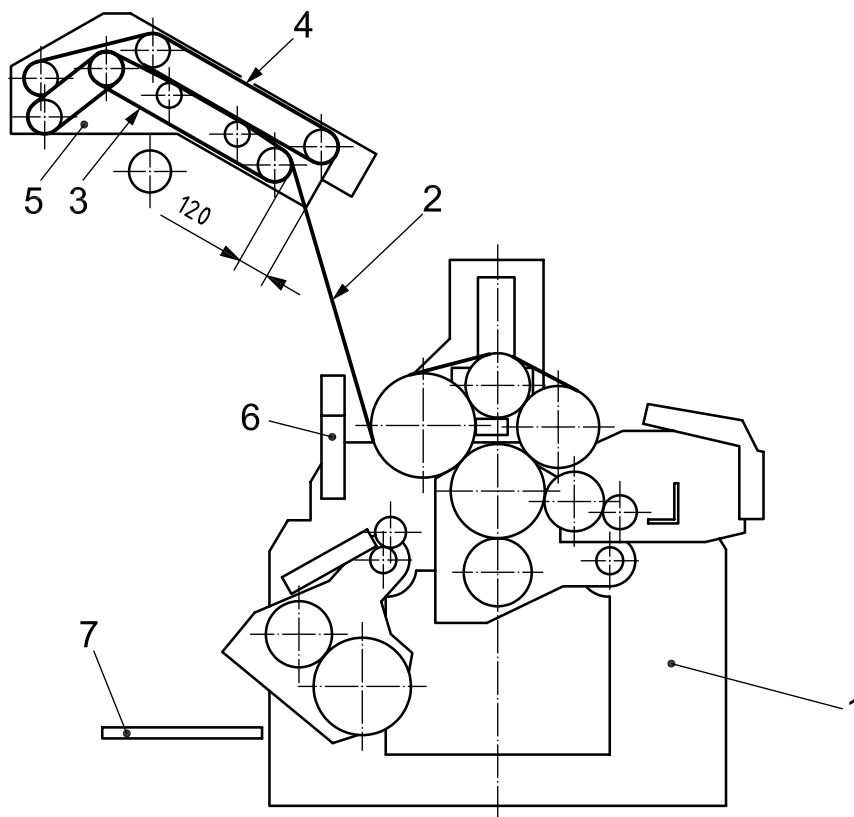

Key

- | | | | |
|---|----------------|---|---------------------|
| 1 | single facer | 5 | bridge |
| 2 | corrugated web | 6 | fall-off protection |
| 3 | lower belt | 7 | walkway |
| 4 | upper belt | | |

Figure 9 — Single facer with inclined belt conveyor

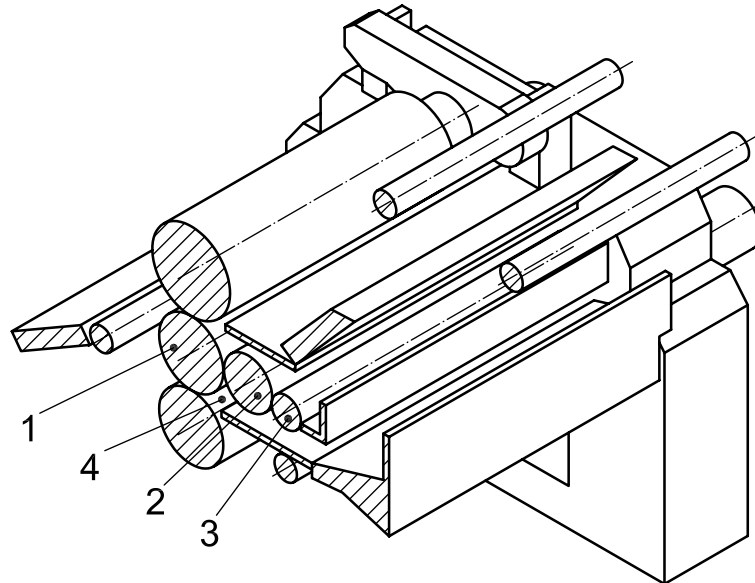
**Key**

- 1 corrugating roller
- 2 glue applicator
- 3 scraper roller
- 4 in-running nip

Figure 10 — Gluing unit**5.5.8 Hazard points between movable gluing unit and fixed machine part**

The hazard points between the movable gluing unit and fixed machine parts (machine frame) shall be safeguarded by one of the following measures:

- a hold-to-run control with at least PL_r c of ISO 13849-1 or SIL 1 of IEC 62061;
- interlocking guards;
- a minimum distance of 25 mm.

5.5.9 Gluing unit cover

The cover of the gluing unit shall be designed to safeguard against gravity falls in accordance with ISO 12643-1.

5.5.10 In-running nips between pulleys and fixed machine parts

The in-running nips between pulleys and fixed machine parts shall be safeguarded by one or both of the following measures:

- a) fixed nip bars designed in suitable sections and extending across the entire working width;
- b) a minimum distance of 120 mm between pulleys or rollers and fixed machine parts.

If fixed nip bars are used, the clearance between the bar and the respective machine part shall not exceed 6 mm.

5.5.11 Steam pipes

When disengaging the steam couplings, the hazardous escape of pressurized steam shall be safeguarded by the following measures:

- coupling systems with relief valves on the ingoing and outgoing sides of the coupling; or
- devices that ensure that the steam supply is cut off and steam is allowed to escape into the work area safely.

Protection shall be provided to ensure that steam escaping unexpectedly during set-up is directed away from personnel.

5.5.12 Warning signs

Single facers shall be provided with signs warning of a burn risk from steam or hot parts.

5.5.13 Drives and drive shafts

Drives and drive shafts shall be safeguarded by fixed guards that contain a movable guard or gate as part of the fixed guard. The movable guard or gate shall be interlocked in accordance with ISO 12643-1.

5.5.14 Noise enclosures

Single facers should be positioned inside noise enclosures. The doors of the enclosure shall close automatically. The enclosure shall be provided with signs pointing out the need to wear ear protection while inside the enclosure. The web feed and take-off openings provided in the noise enclosure shall be designed to minimize the escape of noise into the workroom.

NOTE In Europe, single facers are required to be inside noise enclosures.

Noise enclosures shall be designed such as to allow easy access for make-ready and inspection.

5.6 Inclined belt conveyor

5.6.1 In-running nips

The in-running nips on belts shall be safeguarded by fixed guards.

The in-running nip between the upper belt and the lower belt shall be safeguarded by off-setting the two pulleys in such a way that the minimum clearance between the two rollers is 120 mm (see Figure 9).

There shall be no fixed parts in this area and the belt tension shall be sufficiently low to minimize the risk of drawing in.

5.6.2 Accessible hazard points

Hazard points on the inclined belt conveyor that can be accessed from the bridge or the walkway shall be safeguarded by fixed guards in accordance with ISO 12643-1.

5.7 Bridge

5.7.1 In-running nips

The in-running nips on belts shall be safeguarded by fixed guards in accordance with ISO 12643-1.

The in-running nips between drive rollers and guide rollers of the transport belts and fixed parts of the bridge shall be safeguarded by fixed guards in accordance with ISO 12643-1.

5.7.2 Slots

The slots provided in the surface of the accessible part of a bridge shall not be wider than 50 mm. This requirement does not apply to the walkways alongside the bridge.

NOTE Slots allow humidity to escape from the corrugated board.

5.7.3 Fall-off protection

Fall-off protection shall be provided on both sides of the bridge in accordance with ISO 14122-3.

5.7.4 Access stairs

Access stairs shall be provided for each section of the bridge. The maximum pitch angle specified in ISO 14122-3 is 45°. However, the pitch angle may be increased to a maximum of 60° if justified by the results of the risk analysis specified in ISO 12643-1. Access stairs shall be designed in accordance with ISO 12643-1. Where access stairs connect to a walkway directly (i.e. without a platform), fall-off protection (i.e. a gate) that closes automatically shall be provided.

5.7.5 Passage height underneath the bridge

The passage height underneath the bridge shall be a minimum of 2,10 m. Where this height requirement cannot be met for design reasons, the parts below this height shall be provided with black-yellow padding for protection against impacts.

5.8 Braking and web aligning section

The in-running nips between rollers and between rollers and fixed parts shall be safeguarded by the following measures:

- the use of guards in accordance with ISO 12643-1; or
- maintaining a minimum distance of 120 mm.

5.9 Gluing machine

5.9.1 Steps and handles

Steps and handles meeting the requirements of ISO 12643-1 shall be provided to ensure safe threading of the web and easy access to the gluing units for cleaning.

5.9.2 Hazard points

The hazard points between the glue rollers (see Figure 11, item 3), glue duct (see Figure 11, item 2) and fixed machine parts that are accessible when the glue rollers are moved or removed, or when the glue duct is swung down, shall be safeguarded by one of the following measures:

- a hold-to-run control with at least PL_r c of ISO 13849-1 or SIL 1 of IEC 62061;
- the limitation of automatic movements to 0,5 m/min.

An emergency stop device shall be provided within reach of the operator observing the operation.

5.9.3 Spring-loaded device

The automatic movement of the spring-loaded pressing device (see Figure 11, item 4) applying pressure to the glue shall be safeguarded by one or both of the following measures:

- guarding in accordance with ISO 12643-1;
- allowing the pressing device to deflect at least 25 mm with a maximum spring force of 150 N.

5.10 Heating and pulling section

5.10.1 In-running nips

The in-running nip existing on the in-feed into the heating section between the upper belt (see Figure 11, item 5) or the guide roller (see Figure 11, item 8) and the heating plates (see Figure 11, item 7) shall be safeguarded by guards with a safety distance of 850 mm. The safety distance shall be measured from the point at which the distance between the upper belt or guide roller and the heating plate is 50 mm. Trapping hazards on the guide roller of the upper belt (see Figure 11, item 6) shall be eliminated by providing a fixed guard.

5.10.2 Hazard points

The hazard points between the lower transport rollers or heating plate and the upper weighting device (see Figure 11, item 9) shall be safeguarded by interlocking guards that meet the requirements of ISO 12643-1. Guard openings and safety distances shall be in accordance with ISO 13857.

The hazard point (see Figure 11, item 10) between the upper belt (see Figure 11, item 11) and lower belt (see Figure 11, item 12) at the transition point between the heating and pulling section shall be safeguarded by interlocking guards.

5.10.3 Heating plates

Safety labels shall be placed at any position where it is reasonably foreseeable that personnel may come into contact with the heating plates when guards are open.

5.10.4 Preventing the pressure device from falling

Where access to the area beneath the pressure device is required, one or more of the following measures shall be taken to prevent the pressure device from falling due to gravity:

- self-locking spindles for spindle drives;
- check valves for hydraulic or pneumatic cylinders that are automatically overridden in the operating condition;
- other adequate safety measures.

For inspections, a manually operated mechanical device shall be used to secure the pressure device in a safe position, e.g. locking pins or safety supports.

5.10.5 Crushing hazards

The crushing hazards caused by mechanical devices lifting the corrugated web off the heating plates (see Figure 11, item 15) shall be safeguarded by fixed or interlocking guards.

5.10.6 Vacuum transport belts

Where vacuum transport belts are used, the vacuum fan and exhaust pipes and hoses shall be in accordance with ISO 12643-1 with regard to explosion protection.

5.10.7 Web threading in the heating section

In the area of the heating section, a threading device shall be provided for threading the paper web in order to eliminate the risk of burning.

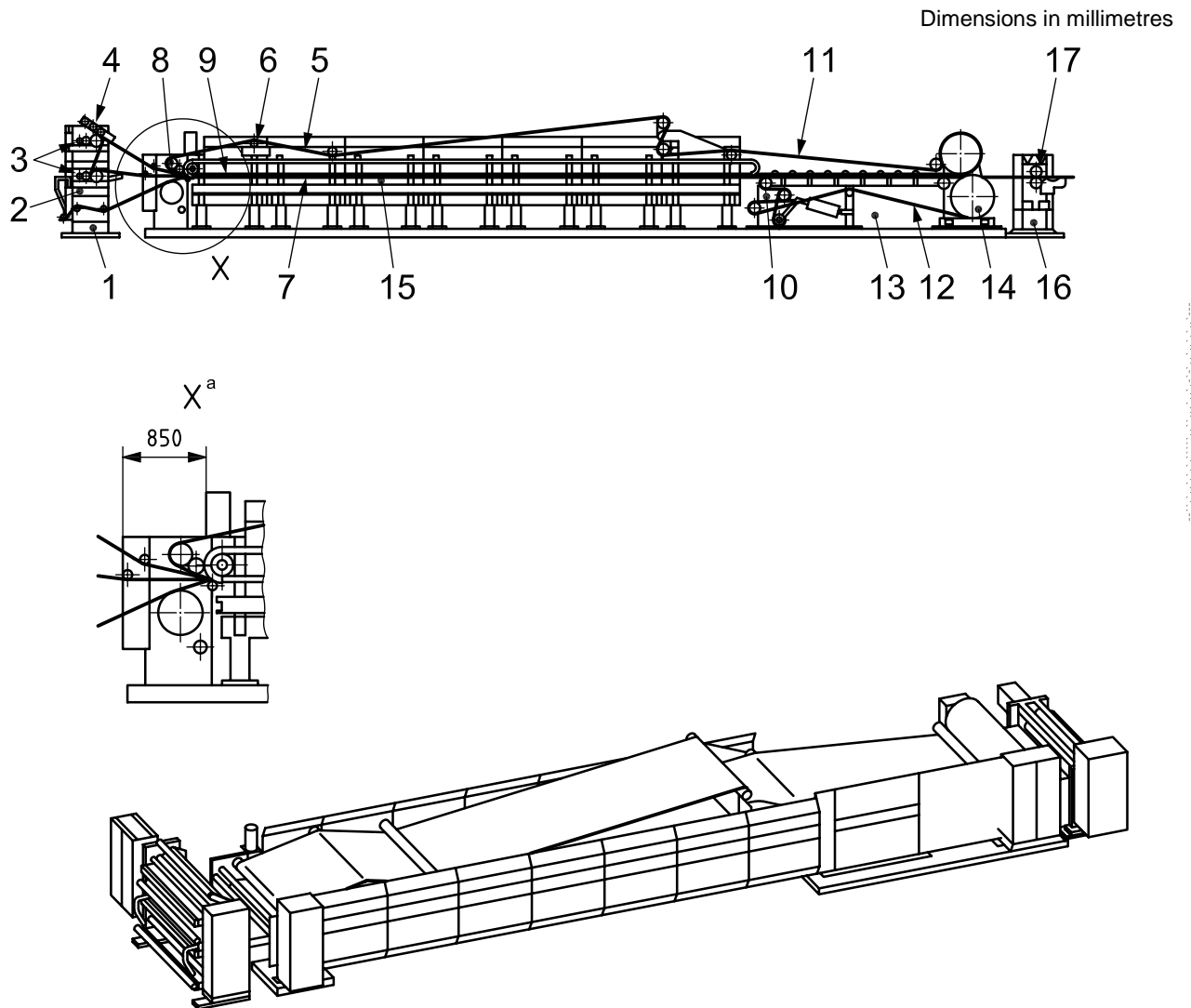

Key

- | | | | | | |
|---|-------------------|----|---|----|-------------------|
| 1 | gluing machine | 7 | heating plates | 13 | pulling section |
| 2 | glue duct | 8 | guide roller | 14 | belt guide roller |
| 3 | glue rollers | 9 | weighting device | 15 | lift-off device |
| 4 | pressing device | 10 | hazard point between upper and lower belt | 16 | rotary shears |
| 5 | upper belt | 11 | upper belt | 17 | knife shaft |
| 6 | belt guide roller | 12 | lower belt | | |

^a Heating and pulling section.

Figure 11 — Gluing machine, heating and pulling section, rotary shears

5.11 Rotary shear unit

5.11.1 Rotary shears

A rotary cutter for cutting the running corrugated web when changing the format and for removing waste material shall be provided.

5.11.2 Knife

The knife driving shaft (see Figure 11, item 17) shall be safeguarded on all sides by fixed and interlocking guards in accordance with ISO 12643-1.

Where there is a risk of personnel being injured by the knife not yet having come to a standstill, guard locking is required. Unlocking of the guard shall only be possible when the knife has come to a standstill.

Guard locking shall meet the requirements specified in ISO 14119.

5.11.3 Guarding a non-powered movement of the knife

On rotary shears where there is a risk of a non-powered movement of the knife, the guard shall also be interlocked with the operation of a braking mechanism to ensure that the knife is held stationary while the guard is open.

NOTE Risk of non-powered movement of the knife can exist, for example, after the clearing of a material blockage.

5.11.4 Waste separator

The hazard points on the waste separator shall be safeguarded by fixed or interlocking guards meeting the requirements of ISO 12643-1. Access from the bottom shall be prevented by guards.

5.11.5 Waste removal

Provisions shall be made for the safe removal of waste.

NOTE Means to remove waste can include movable collection bins or conveyor belts.

Where collecting bins are also used for guarding purposes, they shall be interlocked with the hazardous movement of the waste separator.

5.11.6 Use of personal protection equipment

Personal protection equipment shall be used when changing knives.

For reference on instructions to be given in the instruction handbook, see 13.1.7.

5.12 Pulling unit

5.12.1 Crushing points

The crushing point between the upper and lower discharging rollers when moving the upper discharging roller into position shall be safeguarded.

NOTE Safeguarding can be achieved, for example, by one or both of the following measures:

- hold-to-run control of at least PL_r c of ISO 13849-1 or SIL 1 of IEC 62061;
- fixed or interlocking guards in accordance with ISO 12643-1.

5.12.2 Hazard points below the table

The hazard points in the area below the table (web area) (see Figure 12, item 2) shall be safeguarded by fixed guards in accordance with ISO 12643-1.

5.13 Slitter-scoring units

5.13.1 Guards

The hazard points on the slitter-scoring blade shall be safeguarded by means of fixed guards in accordance with ISO 12643-1. Interlocking gates shall be provided on the in-running and out-running sides to allow safe access for make-ready purposes.

Below the feeding and delivery tables, access shall be prevented by fixed guards in accordance with ISO 12643-1.

5.13.2 Automatic positioning

The automatic positioning of the slitter-scoring blade and the extractor hood shall only be permitted with the interlocking guards in the closed position.

5.13.3 Hoses

Suction hoses for the removal of waste shall be in accordance with ISO 12643-1.

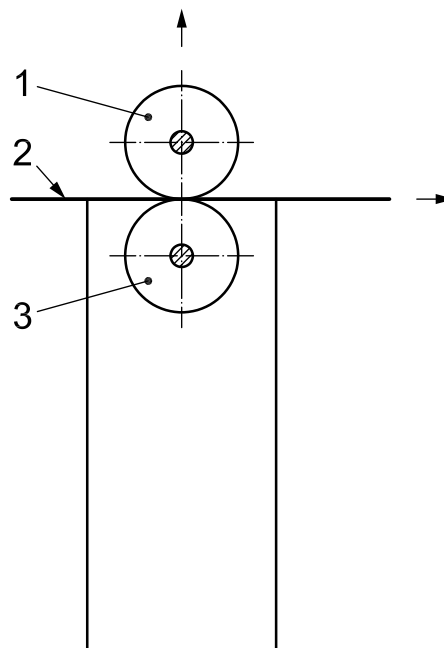

Key

- 1 upper pulling roller
- 2 corrugated web
- 3 lower pulling roller

Figure 12 — Pulling unit

5.13.4 Movement of slitting and scoring units under hold-to-run control

Individual slitting/scoring units shall be allowed to travel under hold-to-run control only at a maximum speed of 5 m/min in accordance with ISO 12643-1. Hold-to-run control shall comply with at least PL_r c of ISO 13849-1 or SIL 1 of IEC 62061. In-running nips between travel wheels and rails shall be safeguarded by fixed guards (deflectors). The distance between fixed guards and rails shall be 15 mm maximum.

With the units moved apart, blades shall only be allowed to be moved under hold-to-run control in accordance with ISO 12643-1. Hold-to-run control shall comply with at least PL_r c of ISO 13849-1 or SIL 1 of IEC 62061.

5.14 Web diverter

The hazard points between the web diverters and fixed parts shall be safeguarded by guards in accordance with ISO 12643-1 (see Figure 13). Access from the bottom shall be prevented by fixed guards in accordance with ISO 12643-1.

5.15 Sheeters

5.15.1 In-running nips on hold-down rolls

The in-running nips on the hold-down rolls shall be safeguarded by fixed guards in accordance with ISO 12643-1.

5.15.2 Machine access

Below the transport tables, access to the machine shall be prevented by fixed guards in accordance with ISO 12643-1 on all sides.

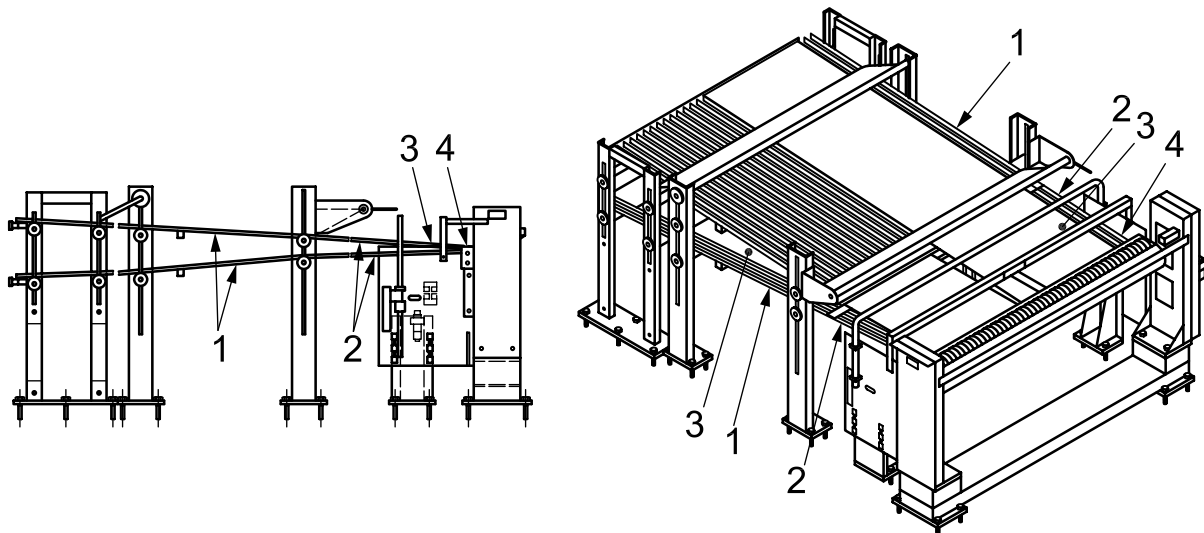

Key

- 1 fixed web guides
- 2 movable web diverters
- 3 corrugated web
- 4 point of rotation of web diverters

Figure 13 — Web diverter

5.15.3 Rotary knives

The hazard points on the rotary knives shall be safeguarded on all sides by interlocking guards in accordance with ISO 12643-1. Where there is a risk of the operator being endangered during knife shaft stopping, the provision of guard locking is required. The opening of the guard shall only be possible when the knife has come to a standstill.

Guard locking shall meet the requirements specified in ISO 12643-1.

5.15.4 Noise

The risks generated by airborne noise emitted from major sources of noise such as transport systems (consisting of pulling and pressure rollers on the discharge side) and cutting systems (consisting of pairs of knife shafts) shall be reduced in accordance with ISO 12643-1.

NOTE Airborne noise can be reduced, for example, by partly or entirely enclosing the major sources of noise with sound-absorbing material such as to provide a complete housing for the sheeter.

If an enclosure is used, openings in the enclosure required for feeding the web and for delivering the blanks shall be provided with silencing elements.

5.16 Stacker devices

5.16.1 In-running nips

The in-running nips on the belts of the conveying system feeding the stacker shall be safeguarded by fixed guards.

5.16.2 Whole-body access

Where whole-body access to conveyor belts feeding the stacker devices is required during production runs, the following measures are required.

- a) Before a person can access the belt, the speed of the belt shall be reduced to 1,5 m/s (90 m/min) maximum. During this time, the control system shall prevent unintended speed increase. After the person has left the belt, the person shall actuate an enabling device that will return the belt to operating speed. The enabling device shall not be within the reach of the person on the belt, and shall be located in a position that ensures the operator of the device has a clear view of the belt.

NOTE Means of reducing the speed and preventing unintended speed increase include, for example, opening a gate interlocked with the speed limit control or use of an ESPD.

- b) A visual warning signal (light) shall flash for at least 5 s before the automatic start of the reduced speed and for the complete duration of the reduced-speed state.
- c) On both sides of the conveyor belt, railings in accordance with ISO 12643-1 shall be provided. There shall also be an intermediate rail 200 mm above conveying level. A toe board is not required.
- d) Movable fall-off protection shall be provided across the conveyor belt at a maximum height of 500 mm and at a distance of at least 1 600 mm from the stacker front. The fall-off protection shall be interlocked with the movement of the conveyor belt and of the stacking device and shall have a black/yellow marking (see Figure 14).

Dimension in millimetres

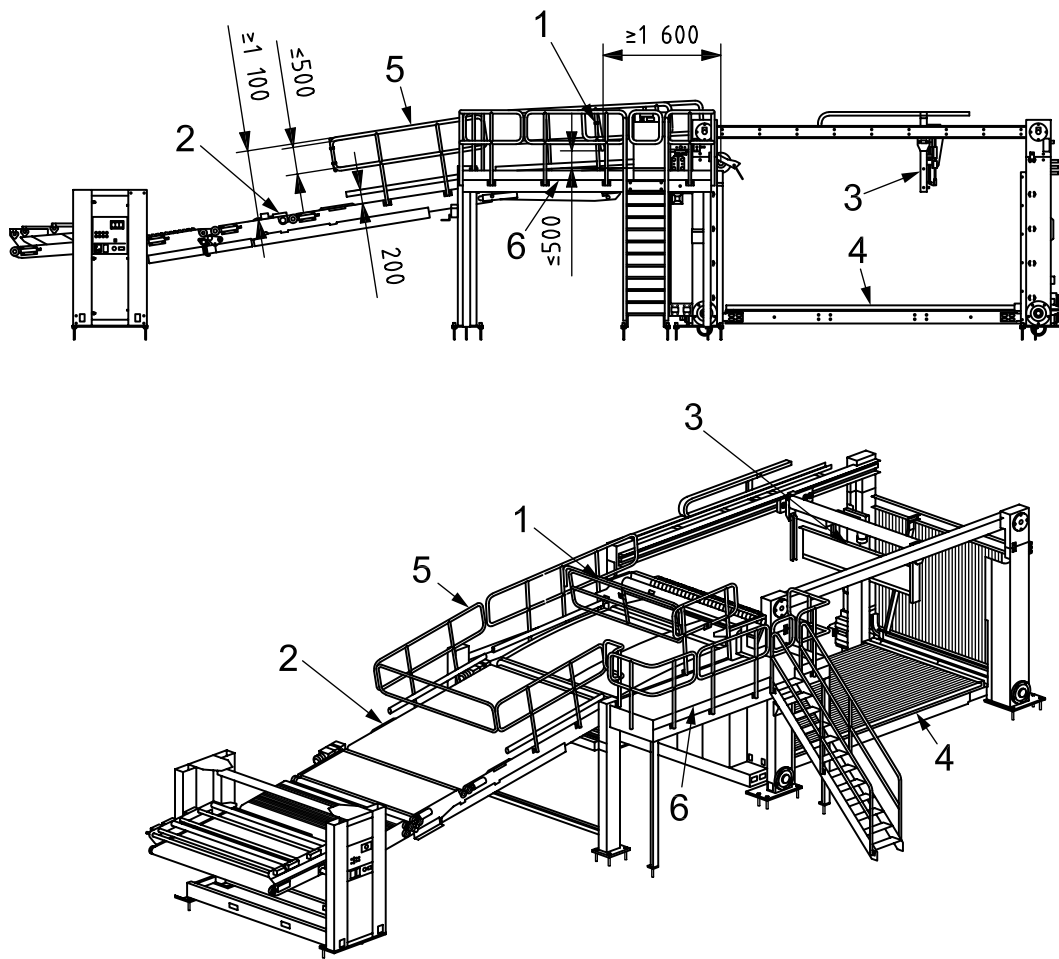

Key

- | | | | |
|---|-----------------------------|---|----------------|
| 1 | movable fall-off protection | 4 | side transport |
| 2 | conveyor belt | 5 | handrail |
| 3 | movable backstop | 6 | catwalk |

Figure 14 — Conveyor belt with fall-off protection

5.16.3 Feeding units, delivery units

The requirements on stacking devices shall meet those specified in ISO 12643-1.

On automatic downstackers (auto-pilers), additional measures shall be taken to ensure that the ascending movement of the pile carrier may only be started if there is no person present on the carrier (see Figure 15).

This requirement shall be met by one or more of the following measures:

- providing parallel safety photoelectric beams with a maximum distance between individual beams of 300 mm and positioned horizontally at a height of 150 mm above the pile carrier plate with the carrier plate in its lowest position; or
- an adequately arranged laser scanner.

The requirements for safeguarding the hazard zone beneath the pile carrier plate shall comply with ISO 12643-1.

Dimensions in millimetres

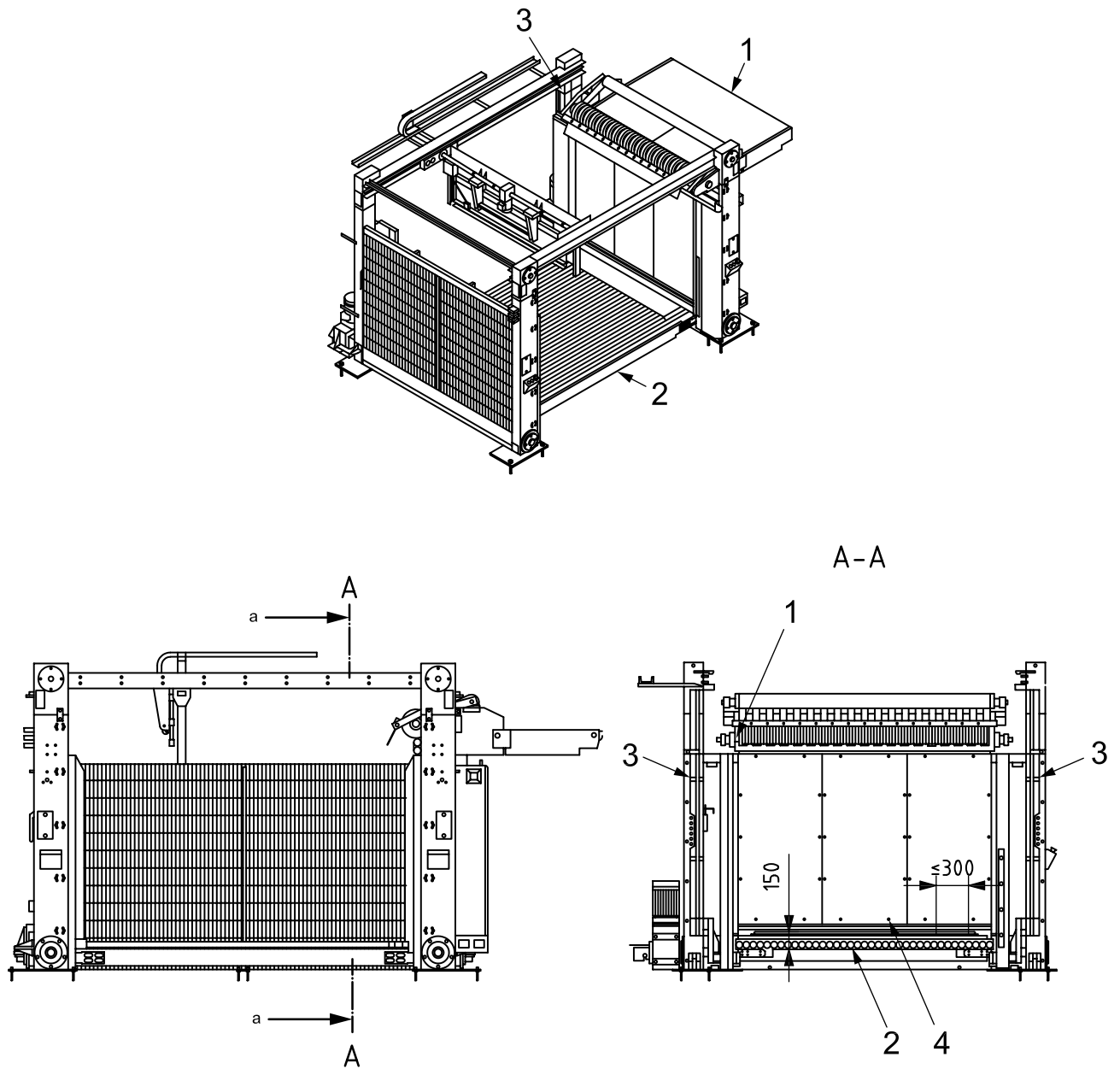

Key

- 1 conveyor belt
- 2 pile carrier (roller conveyor)
- 3 chain
- 4 photoelectric beam

a Path of photoelectric beam.

Figure 15 — Downstacker

5.16.4 Maintenance and inspection

For maintenance and inspection operations, downstackers and upstackers shall each be provided with an adequately rated mechanical device as a stable means of preventing lowering, on downstackers, of the carrier plate or, on upstackers, of the final conveyor belt. Application of that mechanical device shall occur if the pile carrier plate has been lowered down to a maximum distance of 100 mm above the mechanical device.

An interlocking gate shall be provided as the means of access to the hazardous area.

Instructions for securing the plate with mechanical devices to prevent falls due to gravity shall be provided in the instruction handbook. For reference on instructions to be given in the instruction handbook, see 13.1.8.

5.16.5 Guarding of upstackers

On stackers adjusting to varying pile heights (upstackers), the hazard point between the descending conveyor belt and roller conveyor or floor shall be safeguarded (see Figure 16). Access to the conveyor belt in motion shall be prevented by fence-type enclosures on the sides and, on the front, by blinds of sufficient strength and durability to prevent access to the hazardous area.

Where there is a requirement for corrugated sheets to be taken from the conveyor belt feeding the upstacker, the fixed guards provided alongside the conveyor belt can be replaced by the following measures:

- ensuring that the minimum height between the lower edge of the feeding conveyor belt and the floor is always 500 mm;
- providing a warning on the free sides that passage is not permitted (see ISO 12643-1 for information on warning signs);
- providing a chain curtain below the feeding conveyor belt to prevent passage below;
- preventing access to both sides of the area below the feeding belt by providing blinds at the beginning and at the end of the free area on the feeding conveyor belt across the entire width of the feeding belt.

Fence-type enclosures shall meet the requirements specified in ISO 12643-1.

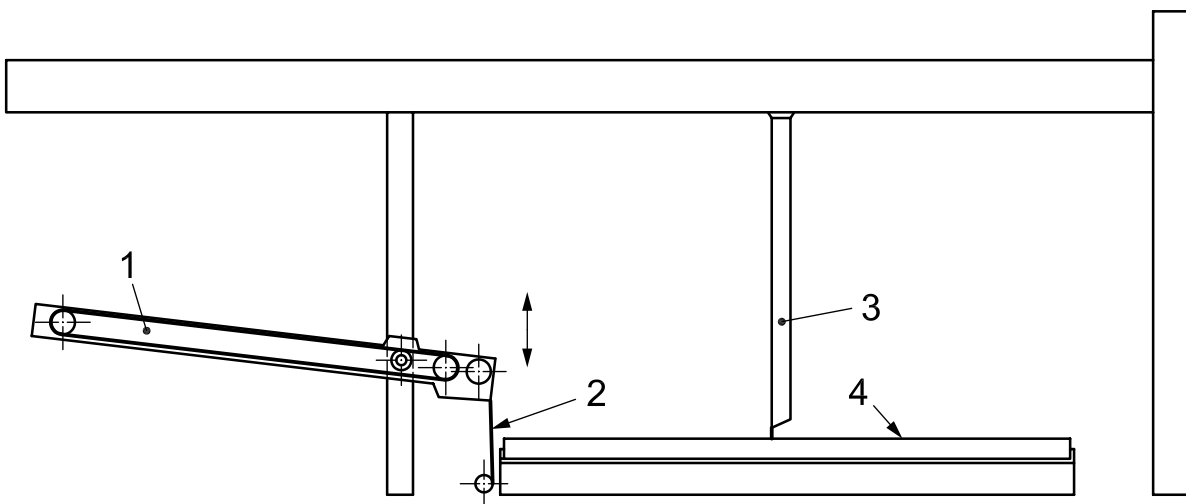

- Key**
- 1 feeding conveyor belt
 - 2 blinds
 - 3 movable side lays
 - 4 roller conveyor

Figure 16 — Upstacker

5.16.6 Roller conveyors

On accessible roller conveyors of stacking devices, the hazard points created by the automatic movement of side lays and fixed machine parts shall be safeguarded by applying the minimum distance of 500 mm. Where the minimum distance cannot be applied, adequate guards in accordance with ISO 12643-1 shall be provided.

For requirements for accessible roller conveyors, see EN 619.

6 Folding box gluer machines

6.1 Entire machine

6.1.1 Audible start-up warning

Folding box gluer machines shall have an audible warning system that complies with ISO 12643-1.

6.1.2 Emergency stop

An emergency stop device shall be provided on or at each motion control station.

6.1.3 Power-driven shafts

Trapping points on power-driven shafts shall be safeguarded by one or more of the following measures:

- telescopic fixed guards which automatically adapt themselves to the size of the format and are not allowed to rotate with the shaft;
- any other adequate measures.

6.1.4 Automatic format setting

Where automatic format setting is a power-driven operation, hazard points shall be safeguarded by one or both of the following measures:

- a hold-to-run control in accordance with ISO 12643-1; the control system of the hold-to-run device shall comply with at least PL_r c of ISO 13849-1 or SIL 1 of IEC 62061;
- limiting the setting speed to a maximum of 0,5 m/min.

6.2 Feeder

The in-running nips between the belt and the guide, tension and drive rollers shall be safeguarded by means of fixed guards designed so as not to create an additional hazard

An example of an acceptable guard is shown in Figure 17.

6.3 Folding section

6.3.1 Roller tracks

The in-running nips between upper and lower roller tracks or folding belt (see Figure 18) shall be safeguarded by the following measures:

- a deflection of the first roller in the roller track of at least 25 mm under a maximum contact force of 70 N;

ISO 12643-4:2010(E)

- a distance of 100 mm between the first roller (see Figure 18, item 3) and the first following roller (see Figure 18, item 5);
- for the following rollers in the roller track, a fixed guard on both outer sides with safety distances in accordance with ISO 13857; such guards shall have no sharp edges.

The hazard points created by the movement of the roller track shall be safeguarded by hold-to-run control in accordance with ISO 12643-1, or by other means that ensures an equivalent level of protection.

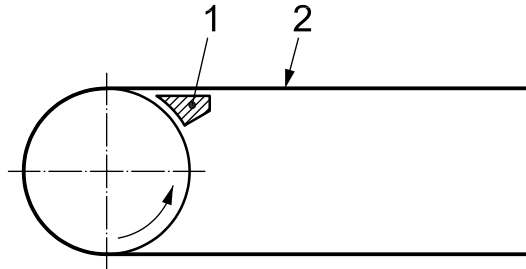

Key

- 1 fixed guard
- 2 belt

Figure 17 — Example of safeguarding the belt in-running nip by fixed guard

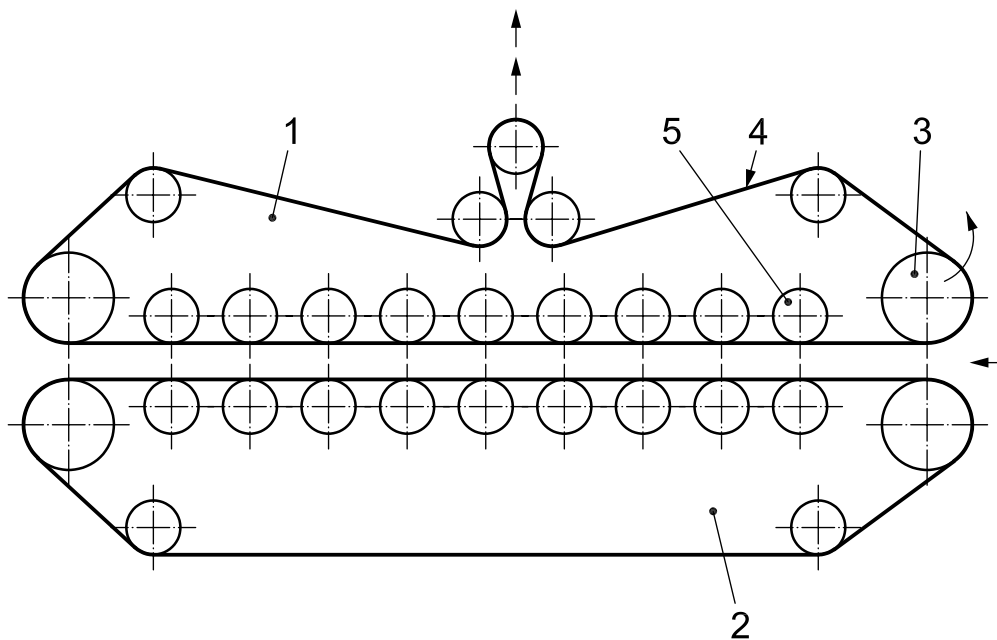

Key

- 1 upper roller track
- 2 lower roller track
- 3 first roller
- 4 folding belt
- 5 following rollers

Figure 18 — Roller tracks

6.3.2 Folding hooks

The hazard points caused by folding hooks (see Figure 19) shall be safeguarded by interlocking guards, or the use of ESPDs that are placed in accordance with ISO 13855.

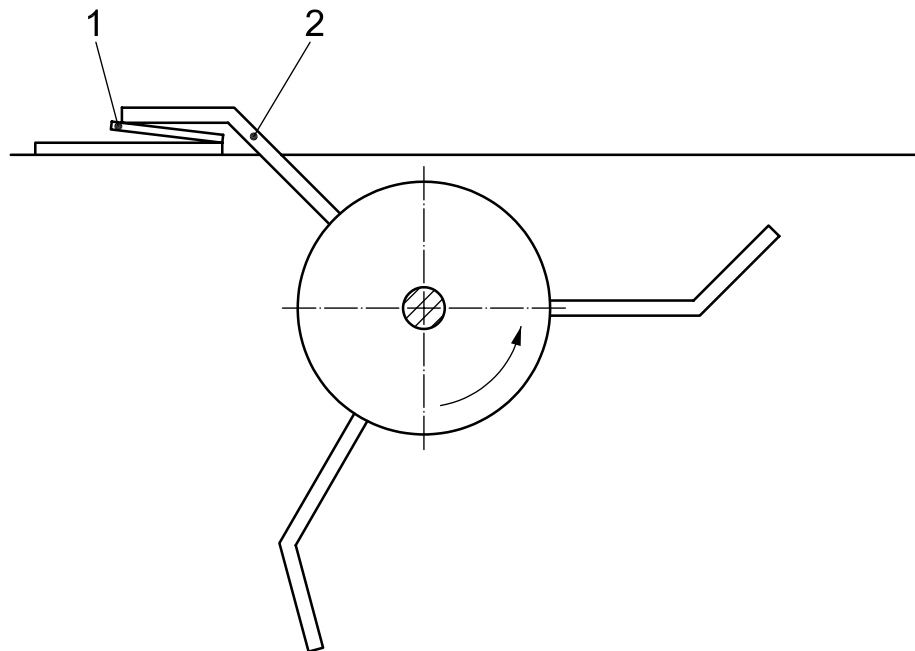

Key

- 1 folded blank
- 2 folding hook

Figure 19 — Folding hook

6.4 Gluing section

The in-running nips between the glue applicator and the blank shall be safeguarded by the use of a fixed guard in accordance with ISO 12643-1, or the use of other adequate measures.

Where hotmelt glue is used, a temperature control device and a separate temperature monitoring device are required.

The glue reservoir shall be insulated.

Safeguards to protect personnel from splashing glue shall be provided.

6.5 Folding belt

The in-running nips between folding belt and pulleys shall be safeguarded by fixed guards (see Figure 17).

The in-running nips between folding belt and hold-down rolls shall be safeguarded by one or more of the following measures:

- hold-down rolls that allow a minimum deflection of 25 mm under a maximum contact force of 70 N;
- fixed and interlocking guards in accordance with ISO 12643-1;
- ESPDs at a distance in accordance with ISO 13857.

6.6 Pressing section

6.6.1 Pulleys

The hazard point between upper and lower pulleys of the pressing belt on the feeding side shall be safeguarded by both of the following measures:

- limiting the pressing force of the pulleys on the feeding side to 500 N;
- a deflection of the pulleys of at least 120 mm.

NOTE This can be done, for example, by arranging the pulleys for the upper and lower pressing belts such that one is not directly below the other and the clearance between the pulleys is at least 120 mm.

See Figure 20.

6.6.2 Pressure rollers

In-running nips between pressure rollers and pressing belt shall be safeguarded by one or both of the following measures:

- fixed guards in accordance with ISO 12643-1;
- a deflection of the pressure rollers of at least 120 mm under a maximum contact force of 100 N.

Dimensions in millimetres

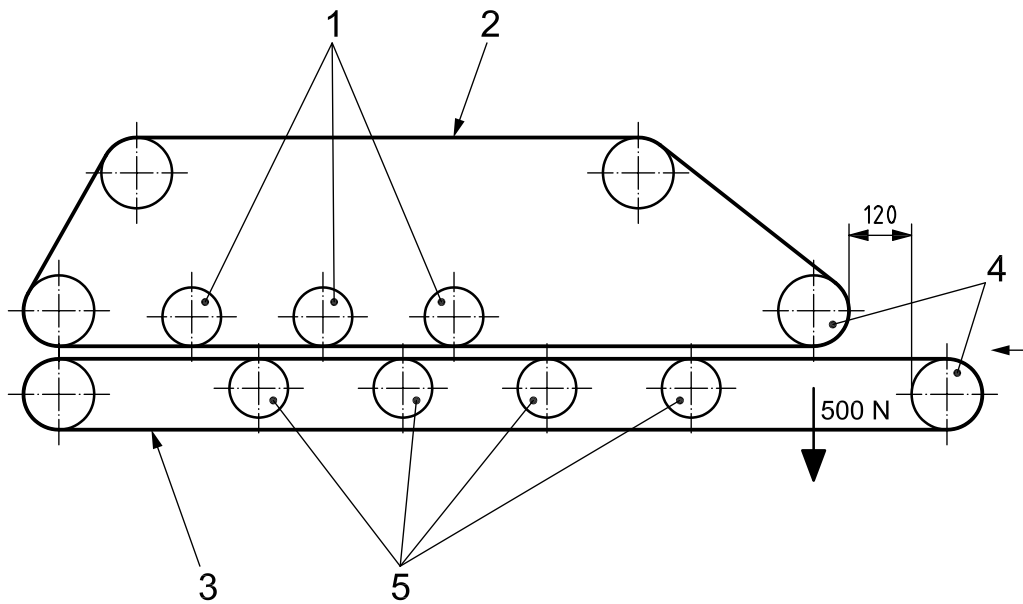

Key

- 1 pressure rollers
- 2 upper pressing belt
- 3 lower pressing belt
- 4 pulleys
- 5 guide rollers

Figure 20 — Pressing section

7 Pre-feeders

7.1 Pre-feeder with pile carrier plate

7.1.1 General

The feeder area shall be designed in compliance with the requirements for feeding units as set forth in ISO 12643-1.

7.1.2 Guarding feeding side

The hazard zone on the feeding side of the feeder area shall be safeguarded with ESPDs (or equivalent protection) to prevent whole-body access in accordance with ISO 12643-1. ESPDs shall be located across the feeding roller conveyor or at floor level.

7.1.3 Guarding sides of feeder area

For safeguarding the feeder area on the sides, fixed guards in accordance with ISO 12643-1 shall be provided. Such guards shall be equipped with an interlocking gate to allow access for fault clearing.

7.1.4 Opening for pallet movement

The aperture for ejection of empty pallets shall comply with ISO 13857.

7.1.5 Guarding on feeding and transfer bridges

The hazardous movements on the feeding and transfer bridge shall be safeguarded by one or both of the following measures:

- a) hold-to-run control with 5 m/min maximum in accordance with ISO 12643-1;
- b) fixed side guards in accordance with ISO 13857.

NOTE Hazardous movements can be lifting, lowering and telescoping movements.

The hazard points between the pushers at the end of the feeding and transfer bridge shall be safeguarded by guards or by a minimum distance of 120 mm.

The hazard points between the pushers and the stack in the hopper of the subsequent in-line machine shall be safeguarded, e.g. by limiting the force to 300 N.

7.1.6 Guarding transport belts

Where in-running nips on transport belts can be accessed, nips shall be guarded in accordance with ISO 12643-1.

7.1.7 Guarding hazards created by automatic format setting

Where a hazard exists, automatic format setting operations may be performed at speeds up to and including 0,5 m/min without additional safety measures. However, if there is a crushing hazard for the head or trunk of the body, format setting shall be permitted only with a hold-to-run control. The location of the hold-to-run control shall allow the operator to clearly see the hazard points.

EXAMPLE Automatic format setting devices include side lays.

ISO 12643-4:2010(E)

If additional safety measures are needed in the area of the format setting device, personnel shall be protected from motion of the device(s) by one or more of the following measures:

- a) the provision of trip devices;
- b) separate stop device that is not included in the emergency stop circuit of the printing press;
- c) zone control using the emergency stop circuit.

7.1.8 Guarding hazards when moving pre-feeder

Hazard points created when moving the pre-feeder into or out of the in-line machinery shall be guarded. These hazard points are considered to be adequately safeguarded if one of the following conditions exists:

- a) the machine travel is possible only under hold-to-run control with a maximum speed of 5 m/min; there is an audible continuous warning signal for the duration of machine travel; and hazard points and hazard zones can be observed from the location of the hold-to-run button;
- b) the hazard zone is safeguarded by fixed guards and ESPDs.

7.2 Pre-feeder with pile turner

7.2.1 Guarding feeding side

The pile turner pre-feeder area in the hazard zone on the feeding side of the feeder area shall be safeguarded with ESPDs (or equivalent protection) to prevent whole-body access in accordance with ISO 12643-1. Safety devices shall be located across the feeding roller conveyor or at floor level.

7.2.2 Guarding sides of pile turner area

For safeguarding the pile turner area on the sides, fixed guards in accordance with ISO 12643-1 shall be provided. Such guards shall be equipped with an interlocking gate to allow access for fault clearing.

7.2.3 Opening for pallet movement

The aperture for ejection of empty pallets shall comply with ISO 13857.

7.2.4 Guarding on feeding and transfer bridge

The hazardous movements on the feeding and transfer bridge shall be safeguarded by one of the following measures:

- a) hold-to-run control with a maximum speed of 5 m/min in accordance with ISO 12643-1;
- b) fixed side guards in accordance with ISO 13857.

NOTE Examples of hazardous movements include lifting, lowering and telescoping movements.

7.2.5 Guarding transport belts

Where in-running nips on transport belts can be accessed, nips shall be guarded in accordance with ISO 12643-1.

The hazard points between the pushers at the end of the feeding and transfer bridge shall be safeguarded by guards or by a minimum distance of 120 mm.

The hazard points between the pushers and the stack in the hopper of the subsequent in-line machine shall be safeguarded, e.g. by limiting the force to 300 N.

7.2.6 Guarding hazards created by format setting

Where a hazard exists, automatic format setting operations may be performed at speeds up to and including 0,5 m/min without additional safety measures. However, if risk assessment shows that there is an unacceptable level of risk, format setting shall be permitted only with a hold-to-run control. The location of the hold-to-run control shall allow the operator to clearly see the hazard points.

If additional safety measures are needed in the area of the format setting device, personnel shall be protected from motion of the device(s) by one or more of the following measures:

- a) the provision of trip devices;
- b) a separate stop device that is not included in the emergency stop circuit of the printing press;
- c) a zone control using the emergency stop circuit.

7.2.7 Guarding hazards when moving pre-feeder

Hazard points created when moving the pre-feeder into or out of the in-line machinery shall be guarded. These hazard points are considered to be adequately safeguarded if one of the following conditions exists:

- a) the machine travel is possible only under hold-to-run control with a maximum speed of 5 m/min; there is an audible continuous warning signal for the duration of machine travel; and hazard points and hazard zones can be observed from the location of the hold-to-run button;
- b) the hazard zone is safeguarded by fixed guards and ESPDs.

Typical examples of moving pre-feeders are given in Figures 21 and 22.

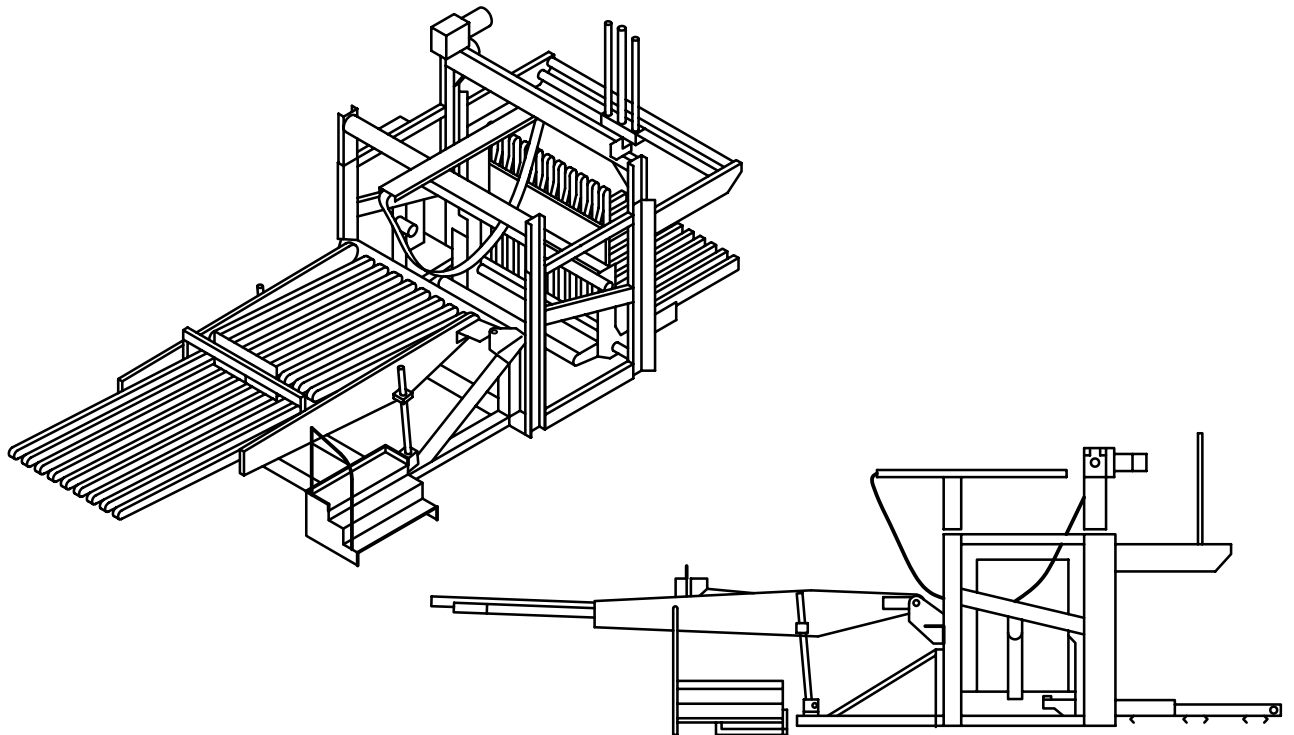

Figure 21 — Pre-feeder with pile turner

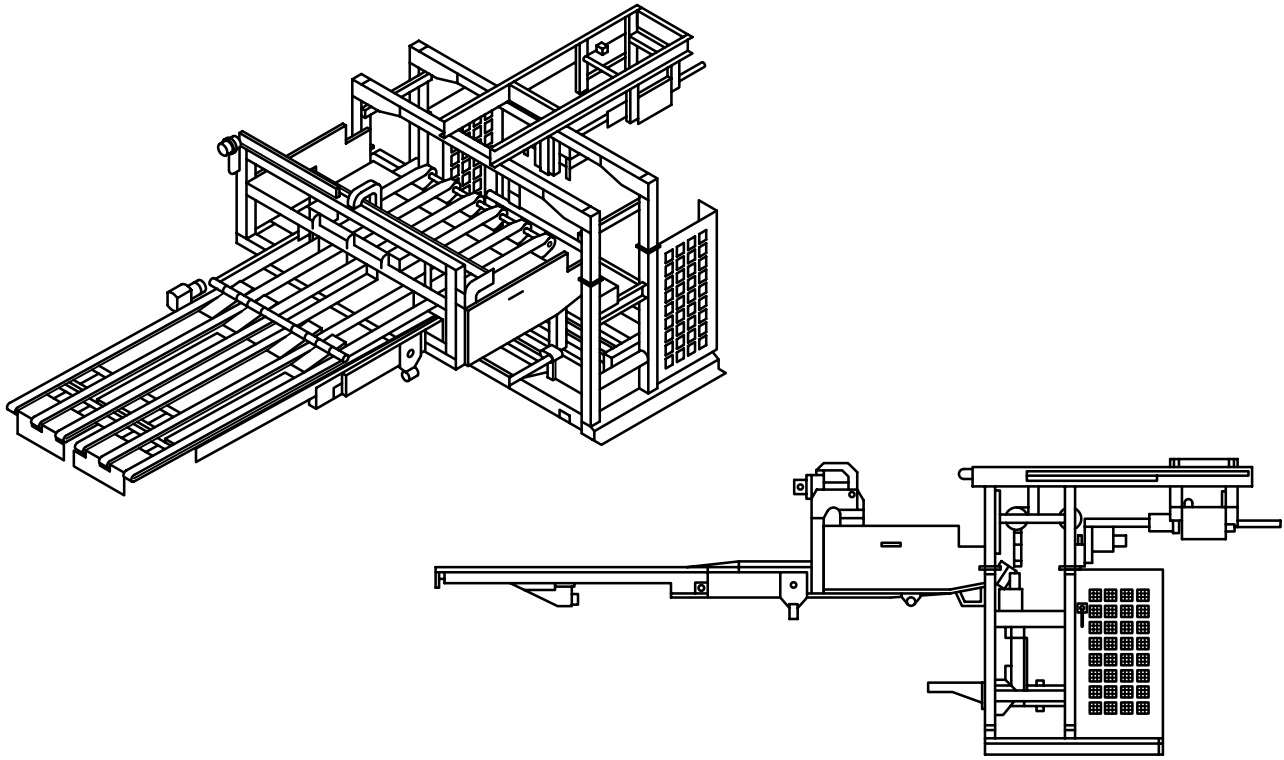

Figure 22 — Pre-feeder with pile carrier plate

8 In-line machines

8.1 Entire machine

8.1.1 Audible start-up warning

In-line machines shall have an audible warning system that complies with ISO 12643-1.

8.1.2 Emergency stop

An emergency stop device shall be provided on or at each motion control station.

8.1.3 Moving units together

When moving the units together, hazard points are created between machine side frames that are deemed to be safeguarded if all of the following conditions are met.

- Movement of the units is possible only under hold-to-run control with a maximum speed of 5 m/min.
- The hold-to-run control is located in such a position that the hazard point cannot be reached by hand, even with fingers spread apart.
- A warning device gives a continuous audible warning signal for the duration of the closing travel of the machine units.

- In the passageways between the individual units, stop/safe devices are provided if the passageways cannot be observed from the location from which the actuator starts the travel movement. All travel movements shall be stopped when the stop/safe device is actuated. Stop/safe devices can be automatically locking actuators or trip wires. The distance between two adjacent actuators shall not be more than 1,5 m. The safety requirements of ISO 13850 shall be met. Signal processing shall comply with ISO 12643-1.

For reference on instructions relating to residual risk to be given in the instruction handbook, see 13.1.9.

8.1.4 Separating units

Separation of the units shall occur only after all hazardous movement has stopped.

8.1.5 Rotary tools on separated units

After separating the units, continuous operation of the rotary tools shall not be possible.

NOTE Examples of such rotary tools include knives, blades, dies, etc.

8.1.6 Travel wheels

The in-running nips between the travel wheels and floor or runway shall be safeguarded, e.g. by providing foot guards fixed such that there is a distance of no more than 15 mm between the runway and the lower edge of the guard.

8.2 Feeding unit

8.2.1 Slide-in rollers

The in-running nips between slide-in rollers (feeder shafts, friction rollers) and fixed machine parts shall be safeguarded by deflecting guarding sections designed in such a way that the deflecting plane is at right angles to the surface of the rotating parts and the distance is as small as possible and does not exceed 4 mm.

8.2.2 Plates and slide-in bars

The hazard points between the suction plates/slide-in bars and fixed parts shall be safeguarded by one or both of the following measures:

- fixed guards in accordance with ISO 12643-1;
- a residual-pile monitoring system in accordance with ISO 12643-1.

8.2.3 Side aligning devices

The hazard points between side aligning devices (side pushers) (see Figure 23, item 3) and fixed machine parts shall be safeguarded by guards or by a minimum distance of 120 mm.

The hazard points between side aligning devices (side pushers) (Figure 23, item 3) and the blank pile (see Figure 23, item 2) in the hopper shall be safeguarded. Safeguarding can be achieved by limiting the force to 300 N.

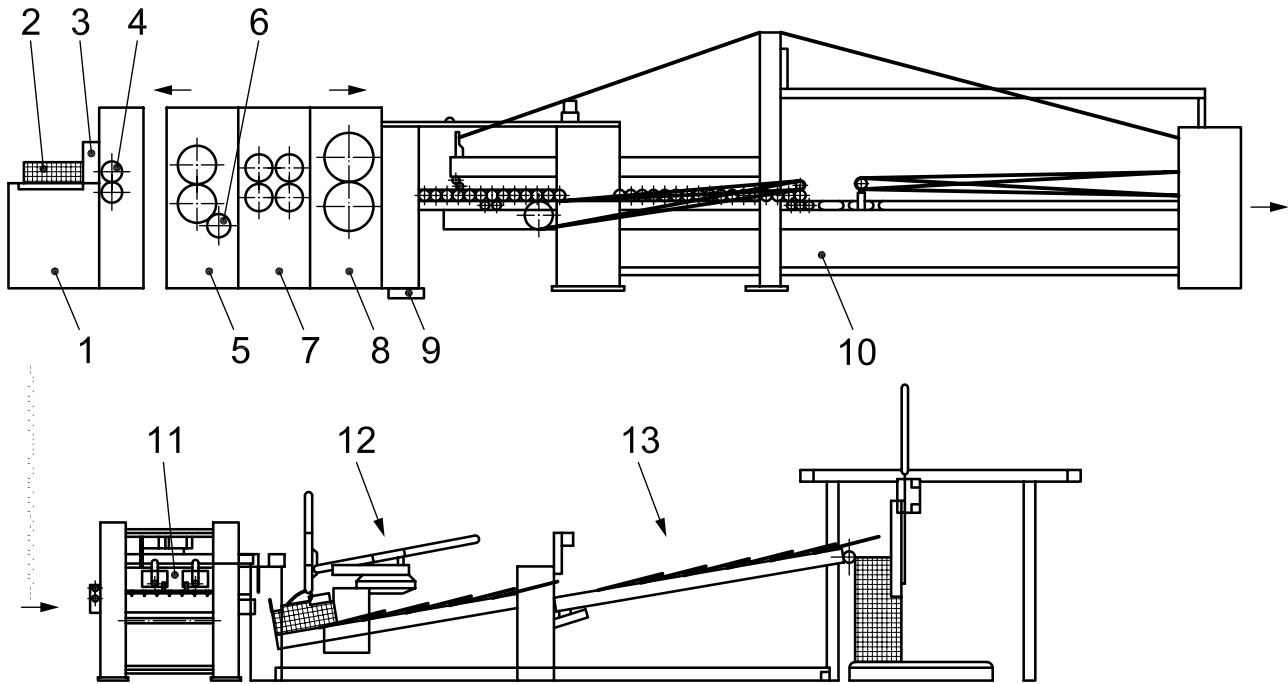

Key

1	feeding unit	6	ink roller	11	stitching unit
2	blank pile	7	slitting and scoring unit	12	counter-ejector and squaring unit
3	side alignment	8	rotary die-cutter	13	delivery
4	feed rollers	9	waste discharge conveyor belt		
5	printing unit	10	folding unit		

Figure 23 — In-line machine

8.2.4 Hopper side lays

The side lays of the hopper create danger points when travelling against fixed machine parts.

Safeguarding shall be provided by one or more of the following measures:

- manual operation of the movement;
- a hold-to-run control with a maximum speed of 5 m/min;
- limiting the travel speed to a maximum of 0,5 m/min, and an emergency stop control located on the delivery side.

8.2.5 Feed rollers

The in-running nips at the feed rollers (see Figure 23, item 4) shall be safeguarded by one or both of the following measures:

- fixed guards;
- residual-pile monitoring in accordance with ISO 12643-1 where guards need to be provided outside the side lays in order to prevent access to the in-running nip for any format used.

As an exception to the requirements of ISO 13857, if feed openings in fixed guards are 30 mm or less, a safety distance of at least 200 mm is allowed. Otherwise, a safety distance of 850 mm is required.

8.2.6 Transport rollers

In-running nips on the transport rollers shall be safeguarded by fixed guards as shown in Figure 17.

8.3 Printing unit

8.3.1 Rotating rollers and drive elements

All hazardous movement shall stop before the units are separated.

8.3.2 Separated units

When the units are separated, a printing unit shall only be allowed to be moved under hold-to-run control in accordance with ISO 12643-1. The hold-to-run speed is limited to 5 m/min. The control system of the hold-to-run device shall comply with ISO 12643-1.

A foot pedal can be used for the hold-to-run operation to allow the operator to use both hands when mounting printing plates.

8.3.3 Changing of printing plates

8.3.3.1 General

The changing of printing plates shall be done with the help of appropriate means for lifting or handling the plates to ensure easy and safe loading and unloading.

8.3.3.2 Automatic printing plate changes

If the changing of printing plates is done by automatic operation, the changing of printing plates may be done without printing units being separated during the plate change.

If the cylinder is rotated by automatic means when mounting the plate to the cylinder, hazard points between the cylinder and fixed machine parts (machine frame) shall be safeguarded by one or more of the following measures:

- a) the use of guards in accordance with ISO 12643-1;
- b) the use of ESPDs in accordance with ISO 12643-1;
- c) safety devices with approach reaction (e.g. trip devices, pressure-sensitive mats).

8.3.3.3 Semi-automatic printing plate changes

If the changing of printing plates is done by semi-automatic operation (i.e. an operator must assist when mounting the plate to the cylinder, and the cylinder is not rotated by automatic means), the hazard points between the cylinder and fixed machine parts (machine frame) shall be safeguarded by one or more of the following measures:

- a) the use of guards in accordance with ISO 12643-1;
- b) the use of hold-to-run control with at least PL_r d of ISO 13849-1 or SIL 2 of IEC 62061;
- c) the use of a foot pedal (designed as a hold-to-run control with at least PL_r d of ISO 13849-1 or SIL 2 of IEC 62061), if the operator needs to use both hands when mounting printing plates. Movement shall be limited to a maximum speed of 5 m/min or maximum distance of 75 mm.

8.3.4 Guarding of rollers

Actuation of an emergency stop control need not cause stopping of the ink roller if continuing movement is required for operational reasons and if all in-running nips on the ink roller are safeguarded by interlocking guards, possibly in combination with fixed guards, in accordance with ISO 12643-1.

When the printing units are in the open position and where rollers such as ink rollers (see Figure 23, item 6) need to continue to be driven for operational reasons, the hazard points shall be safeguarded by interlocking guards.

Where ink rollers need to keep running, there shall be a clearance between the ink roller and the printing cylinder (with printing plate attached) that is sufficient to avoid frictional contact between ink roller and printing cylinder.

8.4 Slitter-scoring unit, rotary die-cutter

8.4.1 Automatic format setting

Automatic format setting shall be possible only when the units are closed.

When units are in the open position, tool setting shall be possible only under hold-to-run control in accordance with ISO 12643-1, with a maximum speed limitation of 5 m/min. The control system of the hold-to-run device shall comply with ISO 12643-1.

8.4.2 Waste removal

The hazard points on the tools provided for breaking out trimmings shall be safeguarded, e.g. by providing a tunnel-type guard allowing removal of the waste while at the same time preventing access.

8.4.3 Waste discharge conveyor belts

Hazard points on waste discharge conveyor belts (see Figure 23, item 9) shall be safeguarded by fixed guards in accordance with EN 619.

Falling down onto waste discharge conveyor belts, for example from floor level, shall be prevented by fall-off protection in accordance with the requirements for working platforms, access stairs, passageways and raised workplaces set forth in ISO 12643-1.

8.4.4 Noise

The risks generated by airborne noise emitted from major sources of noise shall be reduced in accordance with ISO 12643-1.

This can be achieved, for example, by partly or entirely enclosing the major sources of noise with sound-absorbing material; openings in the enclosure required for processes such as feeding the web and for delivering the blanks shall be provided with silencing elements.

In order to minimize hazards generated by vibration, shock-absorbing elements shall be provided between machines and the floor.

8.5 Folding unit (folding box gluer)

8.5.1 Blanks

The area where the blanks are transported shall be safeguarded by a combination of fixed and interlocking guards, or by ESPDs.

8.5.2 In-running nips

In-running nips on glue rollers and between glue rollers and the glue duct shall be safeguarded in accordance with ISO 12643-1.

8.5.3 Folding arms

The hazardous area between the two folding arms shall be safeguarded by the use of fence-type enclosures with interlocking access gates in accordance with ISO 12643-1. When interlocking gates are in an open position, folding arms shall be allowed to move only under hold-to-run control in accordance with ISO 12643-1 if all hazard points and hazard zones can be observed. The control system of the hold-to-run device shall comply with ISO 12643-1.

8.5.4 Power-driven shafts

Power-driven shafts shall be safeguarded by fixed guards in accordance with ISO 12643-1.

8.6 Taping unit

The machine shall be designed such that changing and threading of the adhesive tape shall take place outside hazard zones.

8.7 Stitching unit

8.7.1 Hazard points between upper and lower tool

The hazard points between the upper and the lower tool shall be safeguarded by a combination of fixed and interlocking guards or by other measures safeguarding hazard zones in accordance with ISO 12643-1.

8.7.2 Travel of the stitching unit

Travel of the stitching unit shall be safeguarded by one of the following measures:

- a hold-to-run control in accordance with ISO 12643-1;
- safeguarding the hazard zone in accordance with ISO 12643-1 in the case of automatic travel.

8.7.3 Changing and threading stitching material

The machine shall be designed such that changing and threading of the stitching material shall take place outside hazard zones.

8.7.4 Power-driven shafts

Power-driven shafts shall be safeguarded by fixed guards in accordance with ISO 12643-1.

8.7.5 Delivery unit

The delivery unit shall be guarded in accordance with ISO 12643-1.

9 Automatic flatbed die-cutting machines

9.1 Entire machine

9.1.1 Tool

The movable part of the tool (for example lower part of the die-cutting unit or breaking tool) shall not be allowed to change its position while a guard is open for example, by a non-powered movement or gravity falling. This is achieved on pneumatic and hydraulic cylinders by controlled safety-rated check valves.

9.1.2 Automatic die-cutting devices

Automatic die-cutting devices, in which the form locking between drive worm and flywheel drive is disconnected in case of material jams, shall be provided with adequate safety provisions.

NOTE 1 Adequate safety provisions include:

- brakes;
- mechanical, pneumatic or hydraulic safety bolts.

Failure of the flywheel coupling shall not result in hazardous movements. This can be avoided by automatic mechanical locking of the gripper bars in compliance with PL_r c of ISO 13849-1 or SIL 1 of IEC 62061.

NOTE 2 An example of this is the use of a gripper chain lock to prevent movement of the gripper chain due to a mechanical failure of a flywheel or other component within the drive system that could result in unexpected movement of the gripper chain.

An audible warning system shall be provided in accordance with ISO 12643-1.

For reference on instructions to be given in the instruction handbook, see 13.1.10.

A typical example of an automatic flatbed die-cutting machine is given in Figure 24.

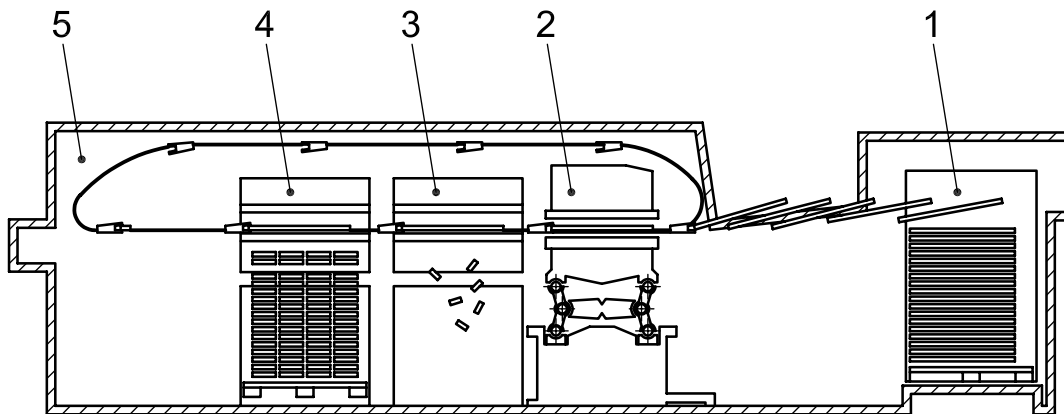

Key

- 1 feeder
- 2 punching section
- 3 breaking section
- 4 blank separating section, delivery
- 5 trimming of gripper edge, delivery

Figure 24 — Automatic flatbed die-cutting machine

9.1.3 Emergency stop devices

Emergency stop devices shall be provided on each operator panel.

9.2 Feeder

9.2.1 Residual-pile monitoring on feeder

When the residual-pile monitoring device is actuated, the hazardous movement of the feeder shall be stopped.

9.2.2 Crushing hazards

Crushing hazards existing between the moving front or side lays and fixed machine parts shall be safeguarded by guards.

9.2.3 Feeding rollers

The hazards on the feeding rollers shall be safeguarded by fixed guards.

As an exception to the requirements of ISO 13857, if feed openings in fixed guards are 30 mm or less, a safety distance of at least 200 mm is allowed. Otherwise, a safety distance of 850 mm is required.

9.3 Punching section

9.3.1 Hazard points between sheet feeding grippers and feeding table

The hazard points between sheet feeding grippers and feeding table shall be safeguarded by guards meeting the requirements of ISO 12643-1. The safety distance in relation to the width of the feeding aperture shall comply with ISO 13857.

9.3.2 Hazard points between upper and lower die

The hazard points between upper and lower die shall be safeguarded by a combination of fixed and interlocking guards meeting the requirements of ISO 12643-1.

For die changing, interlocking guards shall be interlocked with the hazardous movement.

9.3.3 Die-cutting tools

When changing die-cutting tools, the following provisions are required:

- a) the die-cutting tool (formes and chases) shall be capable of being moved in and out of the die-cutting section by means of hinged supporting arms;
- b) the supporting arms shall be designed so that they allow the tool to be lifted and put down by means of hoists, fork trucks or any special device;
- c) fittings shall be provided that secure the tool against gravity falls during removal.

Powered movement in and out of the die-cutting section shall be possible only under hold-to-run control in accordance with ISO 12643-1.

When preparing die-cutting tools, one or both of the following provisions are required:

- a device on the supporting arms for turning the upper and the lower tool with no great effort;
- a separate preparation table outside the automatic die-cutting machine.

9.4 Stripping section

9.4.1 Area below stripping section

When the area below the stripping section cannot be observed from positions from which hazardous movements can be started, the requirements for other safeguarding measures defined in ISO 12643-1 shall be met.

9.4.2 Waste discharge

The in-running nips on the waste discharge conveyor belts shall be safeguarded by fixed guards. Hazard points inside the machine shall not be accessible from the conveyor belt. Safeguarding can be achieved by providing guards in accordance with ISO 12643-1.

Waste exhaust fans, hoses and pipes shall meet the requirements of ISO 12643-1.

9.5 Blank separating section, blank delivery

The hazard points shall be safeguarded by fixed or interlocking guards or ESPDs. Where access to the hazard zone is required, area safeguarding using fence-type enclosures or ESPDs in accordance with ISO 12643-1 shall be provided.

Hazard points on the delivery shall be safeguarded in accordance with ISO 12643-1.

9.6 Trimming and delivery of gripper edge

The hazard points shall be safeguarded by guards interlocked with the hazardous movement. The waste collecting bin can be part of this guarding device. Where the bin is removed for emptying and hazard points can be accessed, the bin shall be interlocked with the hazardous movement.

10 Roller press die-cutters

Roller press die-cutters shall meet the guarding requirements of ISO 12643-1. A trip bar shall be provided at the entrance to and exit from the point of operation to guard against access to the nip created between the roller and the die.

11 Tube winding machines

11.1 Ply reels

Reels of the ply material shall be safely supported for unwinding. For overhung (cantilevered) ply reels, this requirement is met when mechanical devices (e.g. split pins) prevent the reel from falling.

11.2 In-running nips on shaft bearings

On unwinds using insertable unwinding shafts, the shaft bearings shall be designed so that in-running nips are avoided. Otherwise, safeguarding is required by interlocking guards.

11.3 In-running nip between winding belt and winding material

The in-running nip between winding belt and winding mandrel (see Figure 25, item 2, and Figure 26, item 2), shall be safeguarded by fixed and interlocking guards.

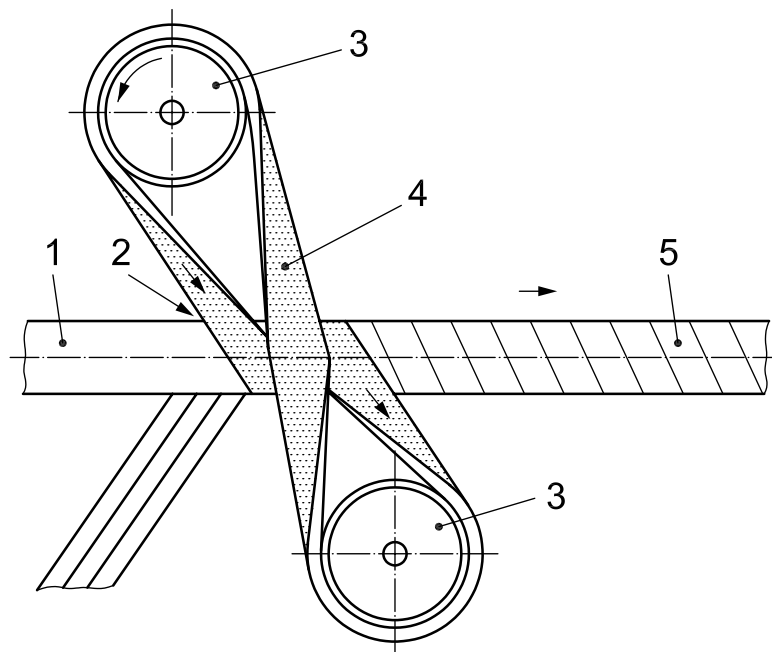

Key

- | | | | |
|---|-------------------------------|---|--------------|
| 1 | winding mandrel | 4 | winding belt |
| 2 | in-running nip | 5 | tube |
| 3 | belt drive shaft (drive drum) | | |

Figure 25 — Winding belt in-running nip on tube winding machine (view of drive drums)

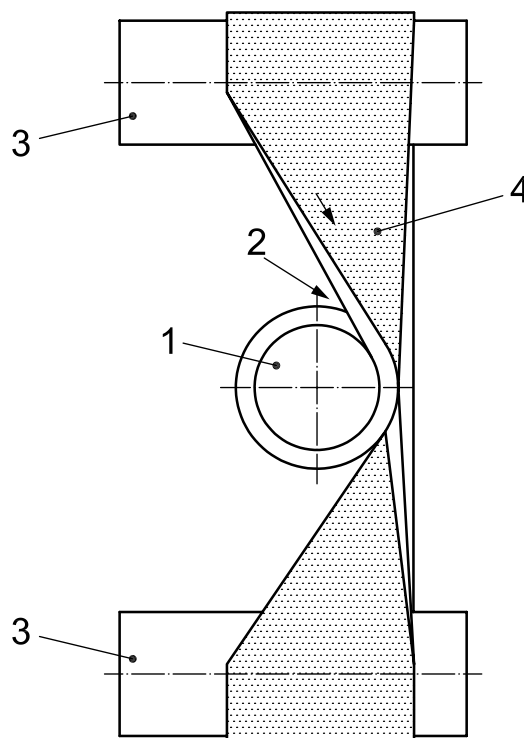

Key

- | | |
|---|-------------------------------|
| 1 | winding mandrel |
| 2 | in-running nip |
| 3 | belt drive shaft (drive drum) |
| 4 | winding belt |

Figure 26 — Winding belt in-running nip on tube winding machine (view of winding mandrel)

For machines that require that the paper be held and pressed onto the winding mandrel with two hands, while the guard is in the open position for threading the ply, the production speed shall be limited to 5 m/min. If the guard does not close within 60 s, the machine shall stop. An additional emergency stop device shall be provided in the vicinity that can be actuated by some part of the body other than the hand (e.g. knee or belly).

Actuation of the emergency stop device shall immediately release the winding belt tension and thus eliminate the in-running nip.

11.4 In-running nips

Guards protecting in-running nips shall be suitable for all winding parameters, including tube diameter, winding diameter, winding angle, ply widths, number of plies, width of winding belt, etc.

NOTE Safeguarding of this type of in-running nip can be achieved by providing adjustable-type guards.

11.5 In-running nips between glue rollers

The in-running nips between glue rollers shall be safeguarded by guards or other means in accordance with ISO 12643-1.

11.6 Tube cutting and sawing section

The hazard points on the tube cutting and sawing section shall be safeguarded by interlocking guards. Such guards may be designed as tunnel-type guards and shall have minimum safety distances of 850 mm on the feeding and the delivery sides.

11.7 Tube transfer

The hazard zone existing during tube transfer between transport elements and fixed machine parts shall be safeguarded.

NOTE Safeguarding of this hazard zone can be achieved by providing tunnel-type guards.

12 Machinery for the production of envelopes

12.1 Printing unit guarding

The in-running nips of the printing unit shall be safeguarded by an interlocking guard meeting the requirements of ISO 12643-1.

After opening the interlocking guard, the printing cylinder or impression cylinder shall only be allowed to continue running if all the following requirements are met.

- a) The in-running nip between the printing cylinder and impression shall be safeguarded by a fixed guard meeting the requirements of ISO 12643-1.
- b) The openings provided on both sides of the guard for introducing the gauge to measure the distance between the impression cylinder and the printing cylinder shall have a maximum width of 33 mm and a maximum height of 20 mm.

NOTE 1 The guard opening is required when introducing a gauge while the machine is at a standstill in order to set the distance precisely between the printing cylinder and the impression cylinder.

- c) A warning sign shall be provided inside the interlocking guard near the hazard.
- d) The speed shall be restricted to 5 m/min.

NOTE 2 Rollers/cylinders need to continue running after the interlocking guard has been opened in order to prevent the ink from drying on the rollers.

12.2 Longitudinal and cross-scoring section

The in-running nips and cutting points in the cross-scoring section shall be safeguarded by interlocking guards meeting the requirements of ISO 12643-1.

The rotary knives for longitudinal scoring shall be safeguarded in accordance with ISO 12643-1.

12.3 Form cutting section

The hazard zones of the knife shall be safeguarded by interlocking guards meeting the requirements of ISO 12643-1. Feed and delivery apertures shall be designed to maintain the safety distances defined in ISO 13857.

12.4 Driven guide rollers

12.4.1 Guarding in-running nips

In-running nips of guide rollers shall be protected by fixed guards meeting the requirements of ISO 12643-1. On guide rollers where the paper guide rails reach from the feeding point to the delivery point, the height of the aperture on the in-running side shall not exceed 10 mm, and the safety distance shall be at least 15 mm.

For troubleshooting, it shall be possible to remove the paper guide rails without dismantling the guard.

12.4.2 Delivery side guards

On the delivery side, the guard shall reach down to at least half the height of the guide roller without creating new in-running nips between the guard and the guide roller.

NOTE This requirement allows for the removal of paper if the format size changes or the web breaks.

12.5 Window cutting section

The hazard zone of the knife in the window cutting section shall be protected by an interlocking guard meeting the requirements of ISO 12643-1. Apertures on the feeding and the delivery sides shall be designed to comply with the safety distances specified in ISO 13857.

12.6 Window material conveying section with unwinding unit

12.6.1 Guarding in-running nips

In-running nips shall be safeguarded by fixed or interlocking guards meeting the requirements of ISO 12643-1. When designing feed and delivery openings for the material, a safety distance in accordance with ISO 13857 shall be maintained.

The in-running nip between the unwinding shaft and the shaft bearing shall be safeguarded by an interlocking guard meeting the requirements of ISO 12643-1.

12.6.2 Unwinding roller

The unwinding roller shall be designed as a smooth-surface roller so that there is no risk of trapping or entanglement.

12.6.3 Guarding hazard zones of splicer knife

The cutting and crushing zones of the splicer knife shall be safeguarded by fixed or interlocking guards meeting the requirements of ISO 12643-1.

12.7 Scraper gluing unit

12.7.1 Guarding in-running nips

The in-running nips between the rollers of the gluing unit shall be safeguarded by fixed or interlocking guards meeting the requirements of ISO 12643-1.

12.7.2 Lifting gluing units

Gluing units that can be lifted shall be secured safely in the lifted position by a self-locking device. The lifting means shall be interlocked with the machine drive.

NOTE Examples of locking devices include latches or self-locking spindles.

12.8 Separating cutting section

12.8.1 Knives

The hazard zones of the knives shall be safeguarded by fixed or interlocking guards meeting the requirements of ISO 12643-1.

12.8.2 Segment roller

The segment roller shall be safeguarded by fixed or interlocking guards meeting the requirements of ISO 12643-1.

12.8.3 Feeding and delivery apertures

The feeding aperture shall be designed to comply with the safety distances defined in ISO 13857. Where the delivery aperture on the segment roller cannot be designed to comply with the safety distances specified in ISO 13857 due to the provision of subsequent machine parts required for reliable paper transport, the opening shall be as small as possible and the safety distance shall be as great as technically feasible.

NOTE Direct access is generally prevented by the subsequent machine parts.

12.9 Bottom flap folding section

12.9.1 Guarding in-running nip

The in-running nip between the bottom flap folding rollers shall be safeguarded by fixed or interlocking guards meeting the requirements of ISO 12643-1.

12.9.2 Feeding and delivery apertures

The feeding aperture shall be designed to comply with the safety distances defined in ISO 13857. Where the feeding aperture cannot be designed to comply with the safety distances of ISO 13857, the aperture shall be as small as possible and the safety distance shall be as great as technically feasible.

The delivery aperture shall be designed to comply with the safety distances defined in ISO 13857.

12.10 Transport rolls

In-running nips of the transport rolls shall be safeguarded by fixed guards meeting the requirements of ISO 12643-1.

Where the diameter of the transport rolls is 40 mm or less, the in-running nip is adequately safeguarded if the rolls can be separated at least 25 mm by a force of 70 N.

12.11 Staggering wheel

12.11.1 Guarding staggering wheel hazards

The hazard zones between the staggering wheel and parts of the machine shall be safeguarded by fixed guards meeting the requirements of ISO 12643-1.

Where gaps are provided between individual staggering wheels, the outer surfaces of the staggering wheels shall be smooth.

NOTE Staggering wheels are used for staggering (separating) the envelopes.

12.11.2 Guarding in-running nips between paper guide supports and staggering wheel

In-running nips between the paper guide supports and the staggering wheel shall be avoided by providing a minimum distance of 25 mm. Where this is not possible, a trip bar as defined in ISO 12643-1 shall be positioned so that the bar is tripped as soon as a finger is drawn in between the paper guide supports and the staggering wheel.

12.12 Roller gluing unit

12.12.1 Guarding in-running nips

The in-running nip between the dosing roller and ductor roller (see Figure 27) shall be safeguarded by fixed or interlocking guards meeting the requirements of ISO 12643-1.

Where scrapers are used instead of dosing rollers, the drawing-in hazard between the scraper and ductor roller may be eliminated by arranging the scraper so that it is close to 90° to the ductor roller surface and the scraper is never more than 4 mm from the ductor roller, even when the scraper is disengaged (see Figure 27 and Figure 28) shall be safeguarded by fixed or interlocking guards meeting the requirements of ISO 12643-1.

12.12.2 Feeding aperture

The feeding aperture shall be designed to comply with the safety distances specified in ISO 13857. Where the feeding aperture cannot be designed to comply with the safety distances of ISO 13857, the aperture shall be as small as possible and the safety distance shall be as great as technically feasible.

NOTE Direct access to the in-running nip is prevented by the staggering wheel located directly in front of the unit.

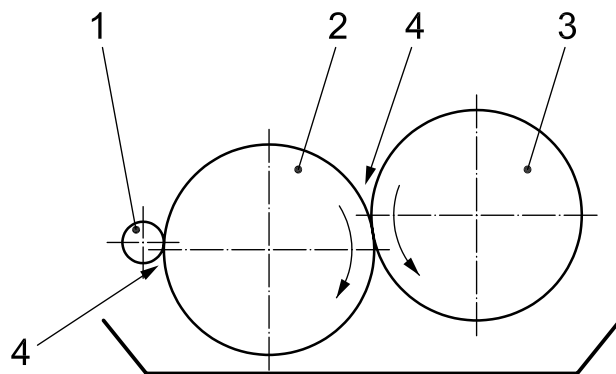

Key

- 1 dosing roller
- 2 ductor roller
- 3 applicator
- 4 in-running nip

Figure 27 — Roller gluing unit with dosing roller

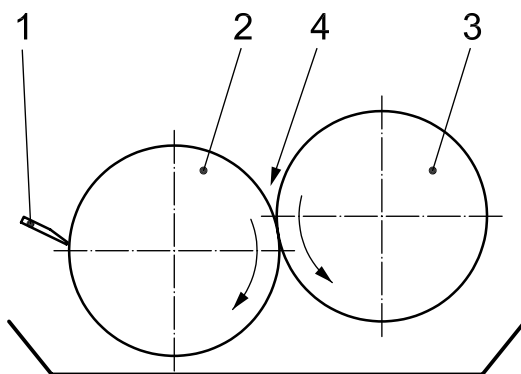

Key

- 1 scraper
- 2 ductor roller
- 3 applicator
- 4 in-running nip

Figure 28 — Roller gluing unit with scraper on the ductor roller

12.12.3 Roller movement after actuation of a stop

Opening an interlocking guard or actuation of an emergency stop device shall not lead to stopping of the dosing roller and the ductor roller if all the hazard zones are safeguarded.

NOTE The dosing roller and ductor roller are required to continue running in order to prevent drying out of the glue.

For reference on instructions to be given in the instruction handbook, see 13.2.3.

12.13 Hot air dryers

12.13.1 Guarding in-running nips

In-running nips of belts shall be safeguarded by fixed or interlocking guards meeting the requirements of ISO 12643-1.

Power-operated tilting nozzles

On power-operated tilting nozzles, the crushing zones shall be safeguarded by fixed or interlocking guards meeting the requirements of ISO 12643-1.

12.13.2 Hot machine parts

Where access to hot machine parts is possible, the surface temperature of the hot machine parts shall not exceed the limit values as specified in ISO 13732-1. If the surface temperature of the hot machine parts exceeds the limit values specified in ISO 13732-1, contact with the hot machine parts shall be prevented by guarding.

NOTE Means of safeguarding against contact with heated parts include the use of insulation or distance guarding.

12.14 Separation roller before aligner section

12.14.1 Guarding in-running nip

The in-running nip shall be safeguarded by fixed or interlocking guards meeting the requirements of ISO 12643-1.

12.14.2 Feeding aperture

The feeding aperture shall be designed to comply with the safety distances specified in ISO 13857. Where the feeding aperture cannot be designed to comply with the safety distances of ISO 13857, the aperture shall be as small as possible and the safety distance shall be as great as technically feasible.

NOTE Direct access to the feeding aperture is generally prevented by preceding parts.

12.15 Aligner section

The in-running nips shall be safeguarded by fixed or interlocking guards meeting the requirements of ISO 12643-1.

12.16 Seal flap folding section

12.16.1 Guarding zone between seal flap folding rollers

The hazard zone between the two seal flap folding rollers shall be safeguarded by fixed or interlocking guards meeting the requirements of ISO 12643-1.

12.16.2 Feeding aperture

The feeding aperture shall be designed to comply with the safety distances specified in ISO 13857. Where the feeding aperture cannot be designed to comply with the safety distances of ISO 13857, the aperture shall be as small as possible and the safety distance shall be as great as technically feasible.

NOTE Direct access to the feeding aperture is generally prevented by following machine elements (transport rolls).

12.17 Separating disc delivery

The in-running nip between the separating disc and the roller located in front of the disc shall be safeguarded by one of the following measures.

- a) Fixed side guides shall cover the in-running nips so as to prevent access by the fingers. In addition, fixed guards shall be provided on the two outer separating discs in order to prevent unintentional access to the discs from the sides.

NOTE 1 The layout of the separating discs generally prevents any unintentional access to in-running nips.

- b) An interlocking guard meeting the requirements of ISO 12643-1 shall cover the separating disc with a delivery opening of the maximum width required for processing the largest format size. The height of the delivery opening shall not exceed 220 mm. The safety distance between the delivery opening and the separating disc shall be at least 550 mm.

The hazard zone between the separating discs and the delivery table shall be safeguarded.

NOTE 2 Safeguarding can be provided, for example, by

- a minimum safety distance of 25 mm between the two parts, or
- a flap hinged to the table of at least 25 mm in width giving way in a downward direction when forces of more than 50 N are applied.

12.18 Starting the machine with interlocking guards open

12.18.1 Hold-to-run speed greater than 10 m/min

Starting the machine with the interlocking guards in the open position and with a hold-to-run speed greater than 10 m/min shall be permitted only by means of a two-hand control, and only if all the following provisions are met:

- the guards in all zones not readily visible to the operator from the operating position shall be closed;
- a selector switch for this kind of operation shall be provided;
- the hold-to-run speed shall be the slowest speed possible under procedural requirements.

12.18.2 Start-up warning device

Envelope machines shall be provided with an audible warning system in accordance with ISO 12643-1.

12.18.3 Noise reduction

Noise reduction measures shall be provided on the machine, particularly on the folding sections, in accordance with ISO 12643-1.

13 Instruction handbook

13.1 Corrugated board machinery

13.1.1 Threading paper web

The instruction handbook shall give detailed descriptions for threading the paper web on splicers and the heating section.

13.1.2 Residual risks relating to hot parts

Where guards or barriers preventing contact with hot machine parts cannot be provided for functional reasons, the instruction handbook shall describe the residual risk.

13.1.3 Hearing protection

The instruction handbook shall specify that ear protection shall be used when entering the noise enclosure of a machine.

13.1.4 Tubes used for material reels

The instruction handbook shall specify that only single-piece tubes are allowed to be used for material reels in the reel stands.

13.1.5 Residual risks on conveyor belts

Where conveyor belts of the stacking devices can be walked on, warning of the residual risk of tripping shall be provided in the instruction handbook.

13.1.6 Warning for hot surfaces

A warning about the possibility of hot surfaces shall be contained in the instruction handbook.

13.1.7 Instruction for use of personal protection equipment when changing knives

The proper use of personal protection equipment when changing knives shall be described in the instruction handbook.

EXAMPLE Cut-resistant gloves.

13.1.8 Instructions for mechanical device on downstackers and upstackers

The instruction handbook shall describe methods of applying the mechanical device during maintenance operations as a stable means to ensure that the lowering of the pile carrier plate is prevented. It shall also indicate that application of the device shall occur if the pile carrier plate has been lowered down to a maximum distance of 100 mm above the mechanical device.

13.1.9 In-line machines

The instruction handbook shall state that, before moving the units together, the operator shall make sure that there is no person present between the units.

The instruction handbook shall state that, when changing printing plates, the gap between the ink roller and the cylinder shall be adequate, as determined by risk assessment, so as not to create a drawing-in hazard.

13.1.10 Automatic die-cutting machines

The audible warning device shall be described in the instruction handbook. It shall indicate that, when the audible warning sounds, no manual intervention on or in the machine is allowed to take place.

13.2 Machines for the production of envelopes**13.2.1 General**

The instruction handbook shall contain a warning about residual risks.

13.2.2 Residual risks between staggering wheels

The instruction handbook shall contain a warning about residual risks between staggering wheels in the vicinity of paper guides if operator intervention is required when starting the machine.

13.2.3 Dosing and ductor rollers

The instruction handbook shall indicate that the dosing and ductor rollers will continue to run after emergency stopping. It shall contain an instruction that, for inspection and repair, the main switch shall be disconnected and shall be secured against resetting.

Bibliography

- [1] ISO 12643-2, *Graphic technology — Safety requirements for graphic technology equipment and systems — Part 2: Prepress and press equipment and systems*
- [2] ISO 12643-3, *Graphic technology — Safety requirements for graphic technology equipment and systems — Part 3: Binding and finishing equipment and systems*
- [3] ISO 12643-5, *Graphic technology — Safety requirements for graphic technology equipment and systems — Part 5: Stand-alone platen presses*

