**Hot-finished structural hollow sections of
non-alloy and fine grain steels —**

**Part 1:
Technical delivery conditions**

Profils creux de construction finis à chaud, en acier non allié ou à grains fins —

Partie 1: Conditions techniques de livraison



Reference number
ISO 12633-1:2011(E)

© ISO 2011



COPYRIGHT PROTECTED DOCUMENT

© ISO 2011

All rights reserved. Unless otherwise specified, no part of this publication may be reproduced or utilized in any form or by any means, electronic or mechanical, including photocopying and microfilm, without permission in writing from either ISO at the address below or ISO's member body in the country of the requester.

ISO copyright office
Case postale 56 • CH-1211 Geneva 20
Tel. + 41 22 749 01 11
Fax + 41 22 749 09 47
E-mail copyright@iso.org
Web www.iso.org

Published in Switzerland

Contents

Page

| | |
|---|-----------|
| Foreword | iv |
| 1 Scope | 1 |
| 2 Normative references | 1 |
| 3 Terms and definitions | 2 |
| 4 Classification and designation | 2 |
| 4.1 Classification | 2 |
| 4.2 Designations | 3 |
| 5 Information to be supplied by the purchaser | 4 |
| 5.1 Mandatory information..... | 4 |
| 5.2 Options | 4 |
| 5.3 Example..... | 5 |
| 6 Requirements..... | 5 |
| 6.1 General | 5 |
| 6.2 Steel manufacturing process | 5 |
| 6.3 Structural hollow section manufacturing process | 6 |
| 6.4 Delivery conditions | 6 |
| 6.5 Chemical composition | 6 |
| 6.6 Mechanical properties..... | 8 |
| 6.7 Technological properties..... | 8 |
| 6.8 Surface condition | 9 |
| 6.9 Non-destructive testing of welds..... | 9 |
| 6.10 Tolerances and mass | 9 |
| 7 Inspection..... | 10 |
| 7.1 Types of inspection and testing | 10 |
| 7.2 Types of inspection documentation..... | 10 |
| 7.3 Inspection and testing | 11 |
| 8 Samples..... | 12 |
| 8.1 Frequency of tests..... | 12 |
| 8.2 Preparation of samples and test pieces..... | 13 |
| 9 Test methods | 14 |
| 9.1 Chemical analysis | 14 |
| 9.2 Mechanical tests..... | 14 |
| 9.3 Visual examination and dimensional inspection | 15 |
| 9.4 Non-destructive testing | 15 |
| 9.5 Retests, sorting and reprocessing | 16 |
| 10 Marking..... | 16 |
| Annex A (normative) Structural hollow sections of non-alloy steels — Chemical composition and mechanical properties | 17 |
| Annex B (normative) Structural hollow sections of fine grain steels — Chemical composition and mechanical properties | 19 |
| Annex C (normative) Location of samples and test pieces for hollow sections..... | 21 |
| Bibliography..... | 24 |

Foreword

ISO (the International Organization for Standardization) is a worldwide federation of national standards bodies (ISO member bodies). The work of preparing International Standards is normally carried out through ISO technical committees. Each member body interested in a subject for which a technical committee has been established has the right to be represented on that committee. International organizations, governmental and non-governmental, in liaison with ISO, also take part in the work. ISO collaborates closely with the International Electrotechnical Commission (IEC) on all matters of electrotechnical standardization.

International Standards are drafted in accordance with the rules given in the ISO/IEC Directives, Part 2.

The main task of technical committees is to prepare International Standards. Draft International Standards adopted by the technical committees are circulated to the member bodies for voting. Publication as an International Standard requires approval by at least 75 % of the member bodies casting a vote.

Attention is drawn to the possibility that some of the elements of this document may be the subject of patent rights. ISO shall not be held responsible for identifying any or all such patent rights.

ISO 12633-1 was prepared by Technical Committee ISO/TC 5, *Ferrous metal pipes and metallic fittings*, Subcommittee SC 1, *Steel tubes*.

This first edition cancels and replaces ISO 630-2:2000, of which it constitutes a minor revision. In particular, better grouping of several documents by subject area and minor editorial improvements have been carried out. In addition, reference number ISO 630-2 has been utilized for a new subject: technical delivery conditions for structural steels for general purposes.

ISO 12633 consists of the following parts, under the general title *Hot-finished structural hollow sections of non-alloy and fine grain steels*:

- *Part 1: Technical delivery conditions*
- *Part 2: Dimensions and sectional properties*

Hot-finished structural hollow sections of non-alloy and fine grain steels —

Part 1: Technical delivery conditions

1 Scope

This part of ISO 12633 specifies the technical delivery requirements for hot-finished hollow sections of circular, square or rectangular form. It is applicable to hollow sections formed hot with or without subsequent heat treatment or formed cold with subsequent heat treatment to obtain equivalent metallurgical conditions to those obtained in the hot-formed product. Fine grain steels are generally delivered in the normalized condition.

The grades, chemical composition and mechanical properties for non-alloy steels and fine grain steels are given in Annexes A and B, respectively.

NOTE 1 For the requirements for tolerances, dimensions and sectional properties, see ISO 12633-2.

NOTE 2 For the technical delivery requirements of hot-rolled structural steels in other product forms, e.g. plates, wide strip, flats, bars and other structural sections, see ISO 630-1 and ISO 630-2.

NOTE 3 For cold-formed structural hollow sections, see ISO 10799-1 and ISO 10799-2.

2 Normative references

The following referenced documents are indispensable for the application of this document. For dated references, only the edition cited applies. For undated references, the latest edition of the referenced document (including any amendments) applies.

ISO 148-1, *Metallic materials — Charpy pendulum impact test — Part 1: Test method*

ISO 377, *Steel and steel products — Location and preparation of samples and test pieces for mechanical testing*

ISO 404, *Steel and steel products — General technical delivery requirements*

ISO 643, *Steels — Micrographic determination of the apparent grain size*

ISO 2566-1, *Steel — Conversion of elongation values — Part 1: Carbon and low alloy steels*

ISO 6892-1, *Metallic materials — Tensile testing — Part 1: Method of test at room temperature*

ISO 6892-2, *Metallic materials — Tensile testing — Part 2: Method of test at elevated temperature*

ISO 9606-1, *Qualification testing of welders — Fusion welding — Part 1: Steels*

ISO 10474:1991, *Steel and steel products — Inspection documents*

ISO 12633-1:2011(E)

ISO 10893-2, *Non-destructive testing of steel tubes — Part 2: Automated eddy current testing of seamless and welded (except submerged arc-welded) steel tubes for the detection of imperfections*

ISO 10893-3, *Non-destructive testing of steel tubes — Part 3: Automated full peripheral flux leakage testing of seamless and welded (except submerged arc-welded) ferromagnetic steel tubes for the detection of longitudinal and/or transverse imperfections*

ISO 10893-6, *Non-destructive testing of steel tubes — Part 6: Radiographic testing of the weld seam of welded steel tubes for the detection of imperfections*

ISO 10893-11, *Non-destructive testing of steel tubes — Part 11: Automated ultrasonic testing of the weld seam of welded steel tubes for the detection of longitudinal and/or transverse imperfections*

ISO 12633-2, *Hot-finished structural hollow sections of non-alloy and fine grain steels — Part 2: Dimensions and sectional properties*

ISO 14284, *Steel and iron — Sampling and preparation of samples for the determination of chemical composition*

ISO 15607, *Specification and qualification of welding procedures for metallic materials — General rules*

ISO 15609-1, *Specification and qualification of welding procedures for metallic materials — Welding procedure specification — Part 1: Arc welding*

ISO 15614-1, *Specification and qualification of welding procedures for metallic materials — Welding procedure test — Part 1: Arc and gas welding of steels and arc welding of nickel and nickel alloys*

3 Terms and definitions

For the purposes of this document, the following terms and definitions apply.

3.1

tube

hollow long product open at both ends of any cross-sectional shape

3.2

structural hollow section

tube intended to be used for structural purposes

3.3

normalizing rolling

rolling process in which the final deformation is carried out in a certain temperature range leading to a material condition equivalent to that obtained after normalizing so that the specified values of the mechanical properties are retained even after normalizing

4 Classification and designation

4.1 Classification

4.1.1 Within the steel grades of the non-alloy steels given in Annex A, three qualities JR, J0, and J2 are specified. These qualities differ with respect to specified impact requirements, method of deoxidation, and limits on values of various elements, with particular reference to sulfur and phosphorus, and inspection and testing requirements.

4.1.2 Within the steel grades of the fine grain steels given in Annex B, two qualities, N and NL, are specified. These differ in respect of the carbon, sulfur and phosphorus content and low-temperature impact properties.

4.2 Designations

4.2.1 For non-alloy steel structural hollow sections, the steel designation consists of:

- a reference to this part of ISO 12633, i.e. ISO 12633-1:2011;
- the capital letter S for structural steel;
- the indication of the minimum specified yield strength for thicknesses ≤ 16 mm, expressed in newtons per square millimetre (N/mm²);
- the capital letters JR for the qualities with specified impact properties at room temperature;
- the capital letter J and a number 0 or 2 for the qualities with specified impact properties at 0 °C and –20 °C respectively;
- the capital letter H to indicate hollow sections.

4.2.2 For fine grain steel structural hollow sections, the steel designation consists of:

- a reference to this part of ISO 12633, i.e. ISO 12633-1:2011;
- the capital letter S for structural steel;
- the indication of the minimum specified yield strength for thicknesses ≤ 16 mm, expressed in newtons per square millimetre (N/mm²);
- the capital letter N to indicate normalized or normalized rolled (see 6.4);
- the capital letter L for the qualities with specified minimum values of impact energy at a temperature of –50 °C;
- the capital letter H to indicate hollow sections.

4.2.3 For modification of the designations in case of special delivery conditions, see 6.4.

4.2.4 The steel shall be designated as illustrated by the following examples:

EXAMPLE 1

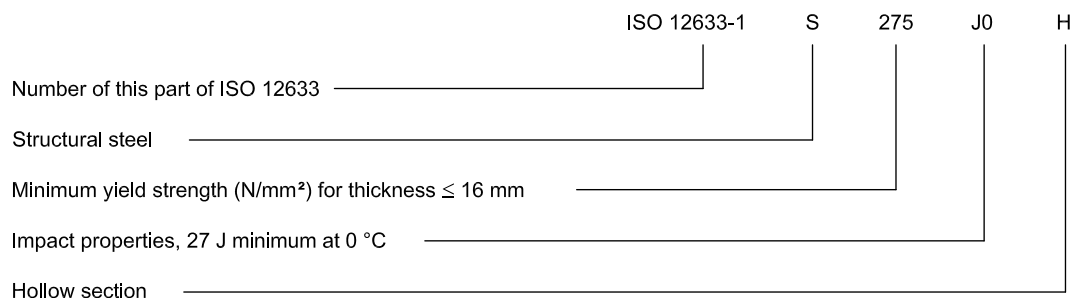

ISO 12633-1:2011(E)

EXAMPLE 2

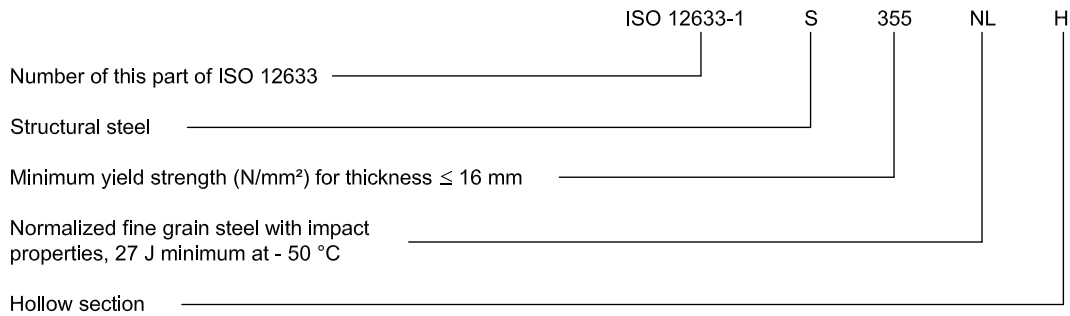

NOTE Steel names used in this part of ISO 12633 differ from those in ISO/TS 4949.

5 Information to be supplied by the purchaser

5.1 Mandatory information

The following information shall be supplied by the purchaser at the time of enquiry and order:

- the quantity (mass or total length or number);
- the type of length and length range or length (see ISO 12633-2);
- details of the product form:
HFCHS = hot-finished circular hollow sections;
HFRHS = hot-finished square or rectangular hollow sections;
- the steel designation (see 4.2);
- the dimensions (see ISO 12633-2);
- the options required (see 5.2);
- the type of inspection document required (see 7.2 and Tables 2 and 3).

5.2 Options

A number of options are specified in this part of ISO 12633; they are listed in this subclause with the appropriate clause references. In the event that the purchaser does not indicate his/her wish to implement any of these options at the time of enquiry and order, the products shall be supplied in accordance with the basic specification (see 5.1).

- Option 1: product analysis shall be carried out (see 6.5.1).
- Option 2: a maximum carbon equivalent value (CEV) in accordance with Table A.2 shall be provided for non-alloy grades (see 6.5.2).
- Option 3: the Cr, Cu, Mo, Ni, Ti and V cast analysis contents shall be reported in the inspection certificate or inspection report for non-alloy grades (see 6.5.2).
- Option 4: a maximum carbon equivalent value in accordance with Table B.2 shall be provided for fine grain steels S275 and S355 (see 6.5.3).

- e) Option 5: the cast analysis limits for grade S460 (see 6.5.3) shall be:
 - 1) $V + Nb + Ti \leq 0,22 \%$; and
 - 2) $Mo + Cr \leq 0,30 \%$.
- f) Option 6: impact properties of quality J0 and JR shall be verified by test. This option applies only when products are ordered with specific inspection and testing (see 6.6.4).
- g) Option 7: the material shall be suitable for hot dipped galvanized coating (see 6.7.2).
- h) Option 8: weld repairs to the body of non-alloy structural steel hollow sections shall not be permitted (see 6.8.4).
- i) Option 9: specific inspection and testing for non-alloy grades of qualities JR and J0 shall be applied (see 7.1.1).

5.3 Example

| | | | | | | | |
|---|--|---------|---------------|-----------|-----------------|---------------|-------|
| 10 t | 12 m approximate + option 1 from ISO 12633-2 | HFRHS - | ISO 12633-1 - | S355J0H - | 100 × 100 × 8 - | Option 6, 9 : | 3.1.B |
| Quantity and type of length (see ISO 12633-2) | | | | | | | |
| Product form | | | | | | | |
| Number of this part of ISO 12633 | | | | | | | |
| Steel grade | | | | | | | |
| Size and thickness (see ISO 12633-2) | | | | | | | |
| Options 6 and 9 from this part of ISO 12633 | | | | | | | |
| Type of inspection document selected from ISO 10474 | | | | | | | |

6 Requirements

6.1 General

Structural hollow sections of non-alloy steels shall comply with the requirements of Annex A; structural hollow sections of fine grain steels shall comply with the requirements of Annex B.

6.2 Steel manufacturing process

6.2.1 The steel manufacturing process shall be at the discretion of the steel producer.

6.2.2 For the non-alloy structural steels given in Annex A, the method of deoxidation shall be as given in Table A.1.

6.2.3 For the fine grain steels given in Annex B, the method of deoxidation shall be as given in Table B.1.

6.2.4 The fine grain steels given in Annex B shall have a ferritic grain size equal to or finer than 6 when measured in accordance with ISO 643.

6.3 Structural hollow section manufacturing process

6.3.1 Structural hollow sections shall be manufactured by a seamless or by a welding process. Welded sections manufactured by a continuous process shall not include welds used for joining lengths of the flat rolled-strip prior to forming the hollow section, except as permitted in 9.4.3.

6.3.2 Electric welded hollow sections are normally supplied without trimming the internal weld bead.

6.3.3 For quality assurance requirements, see ISO 404. If the purchaser specifies quality assurance, an appropriate International Standard, such as ISO 9001, can be used.

6.4 Delivery conditions

6.4.1 The hollow sections shall be delivered in the following conditions:

- qualities JR, J0 and J2: hot-finished;
- qualities N and NL: normalized (normalized includes normalized rolled).

6.4.2 It may be necessary for seamless hollow sections with a wall thickness above 16 mm or when *TID* is greater than 0,15 to apply accelerated cooling after austenitizing to achieve the intended structure or liquid quenching and tempering to achieve the mechanical properties. The decision shall be left to the discretion of the manufacturer, but shall be stated to the purchaser at the time of enquiry and order. Hollow sections treated in such a way shall be designated in the following ways:

- a) for accelerated cooling: by the steel name supplemented by the symbol “+DC”;
- b) for quenching and tempering:
 - 1) by the steel name supplemented by the symbol “+QT” in the case of non-alloy steels;
 - 2) by a modified steel name for which the letter N is replaced with Q in cases of fine grain steels, e.g. S460QLH.

Details of the special delivery conditions shall be given in the inspection document and the product shall be marked in accordance with the above-mentioned stipulations.

NOTE Cold-formed hollow sections with subsequent heat treatment to obtain equivalent metallurgical conditions to those obtained by normalizing rolling are deemed to meet the requirements of this part of ISO 12633.

6.5 Chemical composition

6.5.1 The cast analysis reported by the steel producer shall apply and shall comply with the requirements of Tables A.1 and B.1.

Option 1 (see 5.2): a product analysis shall be carried out for hollow sections supplied with specific inspection and testing.

The permissible deviations of the product analysis from the specified-limits cast analysis are given in Table 1.

Table 1 — Permissible deviations of the product analysis from the specified limits of the cast analysis

| Element | Permissible maximum content in the cast analysis | Permissible deviation of the product analysis from specified limits for the cast analysis |
|---------------------|--|---|
| | mass fraction % | mass fraction % |
| C ^a | ≤ 0,20 | +0,02 |
| | > 0,20 | +0,03 |
| Si | ≤ 0,60 | +0,05 |
| Mn | non-alloy ≤ 1,60 | +0,10 |
| | fine grain ≤ 1,70 | −0,05 +0,10 |
| P | non-alloy ≤ 0,045 | +0,010 |
| | fine grain ≤ 0,035 | +0,005 |
| S | non-alloy ≤ 0,045 | +0,010 |
| | fine grain ≤ 0,030 | +0,005 |
| Nb | ≤ 0,060 | +0,010 |
| V | ≤ 0,20 | +0,02 |
| Ti | ≤ 0,03 | +0,01 |
| Cr | ≤ 0,30 | +0,05 |
| Ni | ≤ 0,80 | +0,05 |
| Mo | ≤ 0,10 | +0,03 |
| Cu | ≤ 0,35 | +0,04 |
| | 0,35 < Cu ≤ 0,70 | +0,07 |
| N | ≤ 0,025 | +0,002 |
| Al _{Total} | ≥ 0,020 | −0,005 |

^a For S235JRH for thicknesses less than or equal to 16 mm, the permissible deviation is 0,04 % C, and for thicknesses greater than 16 mm and less than or equal to 40 mm, the permissible deviation is 0,05 % C.

When a CEV is required it shall be determined from the cast analysis using the formula:

$$CEV = C + \frac{Mn}{6} + \frac{Cr + Mo + V}{5} + \frac{Ni + Cu}{15}$$

6.5.2 For non-alloy steel products, the following additional requirements may be requested at the time of enquiry and order for products supplied with specific inspection and testing (see 7.1).

Option 2 (see 5.2): the CEV in accordance with Table A.2.

Option 3 (see 5.2): the recording on the inspection certificate or inspection report of the Cr, Cu, Mo, Ni, Ti and V content (cast analysis).

6.5.3 For fine grain steel hollow sections, the following additional requirements may be requested at the time of enquiry and order.

Option 4 (see 5.2): the CEV for steel grades S275 and S355 in accordance with Table B.2.

ISO 12633-1:2011(E)

Option 5 (see 5.2): for steel grade S460, the following limits for the cast analysis:

$$V + Nb + Ti \leq 0,22 \% \quad \text{and} \quad Mo + Cr \leq 0,30 \%$$

A maximum CEV may be agreed between the purchaser and manufacturer as an alternative to option 5.

6.6 Mechanical properties

6.6.1 Under the inspection and testing conditions as specified in Clause 7 and in the delivery condition as specified in 6.4, the mechanical properties shall comply with the relevant requirements of Tables A.3 and B.3.

Stress relief annealing at more than 580 °C or for over 1 h may lead to deterioration of the mechanical properties. If the purchaser intends to stress relief anneal the products at higher temperatures or for longer times, the minimum values of the mechanical properties after such a treatment should be agreed at the time of the enquiry and order.

6.6.2 For impact tests, standard V-notch test pieces (see ISO 148-1) shall be used. If the nominal product thickness is not sufficient for the preparation of standard test pieces, the test shall be carried out using test pieces of width less than 10 mm, but not less than 5 mm. The minimum average values given in Tables A.3 and B.3 shall be reduced in direct proportion to the actual width of the test piece to that of the standard test piece.

Impact tests are not required for nominal thickness less than 6 mm.

6.6.3 For fine grain steel hollow sections in thicknesses which do not permit impact test pieces of width greater than or equal to 5 mm to be taken, the ferritic grain size (see 6.3.2) shall be verified by the method described in ISO 643.

When aluminium is used as the grain refining element, the grain size requirement shall be deemed to be fulfilled if the cast analysis shows the aluminium content to be not less than 0,020 % total aluminium or alternatively 0,015 % acid soluble aluminium. In these cases, verification of the grain size is not required.

6.6.4 Subject to the limitations of 6.6.2:

- a) the impact properties of structural hollow sections of steel qualities J2, N and NL shall be verified;
- b) the impact properties of structural hollow sections of steel qualities JR and J0 are not verified.

Option 6 (see 5.2): the purchaser may request at the time of enquiry and order, for products supplied with specific inspection and testing (see option 9), that the impact properties be verified.

6.7 Technological properties

6.7.1 Weldability

The steels specified in this part of ISO 12633 shall be suitable for welding by all appropriate welding processes.

NOTE 1 With increasing product thickness, increasing strength level and increasing carbon equivalent level, the occurrence of cold cracking in the welded zone forms the main risk. Cold cracking is caused by the following factors in combination:

- the amount of diffusible hydrogen in the weld metal;
- a brittle structure of the heat affected zone;
- significant tensile stress concentrations in the welded joint.

NOTE 2 When using recommendations as laid down in any relevant standard, the recommended welding conditions and the various welding ranges of the steel grades can be determined depending on the product thickness, the applied welding energy, the design requirements, the electrode efficiency, the welding process and the weld metal properties.

6.7.2 Hot dip galvanized coating

Option 7 (see 5.2): at the time of enquiry and order, the purchaser may request that the products be suitable for hot dip galvanized coating.

6.8 Surface condition

6.8.1 The hollow sections shall have a smooth surface corresponding to the manufacturing method used; however, bumps, cavities or shallow longitudinal grooves resulting from the manufacturing process are permissible, provided the remaining thickness is within tolerance.

Surface defects may be removed by the manufacturer by grinding, provided the thickness of the hollow section after the repair is not less than the minimum permissible thickness. (See ISO 12633-2 for thickness tolerance.)

6.8.2 The ends of the hollow section shall be cut nominally square with the axis of the product.

6.8.3 For both non-alloy and fine grain structural steel hollow sections manufactured by a welded process, repair of the weld shall be permitted.

6.8.4 For non-alloy structural steel hollow sections manufactured by either a seamless or welding process, repair of the body by welding shall be permitted unless otherwise specified. The conditions under which, and the extent to which, welding repair to the body may be carried out shall be agreed between the manufacturer and the purchaser.

Option 8 (see 5.2): the purchaser may specify at the time of enquiry and order that repair of the body by welding shall not be carried out.

For fine grain structural steel hollow sections manufactured by either a seamless or welded process, repair of the body by welding shall not be permitted unless otherwise agreed.

6.8.5 Welding repair shall be carried out by operators qualified in accordance with ISO 9606-1. Welding repair procedures shall be in accordance with ISO 15607, ISO 15609-1 and ISO 15614-1. The repair welding procedures shall be covered by the manufacturer's quality assurance system.

6.8.6 The repaired hollow section shall comply with all the requirements of this part of ISO 12633.

6.9 Non-destructive testing of welds

The seam weld of all welded hollow sections supplied with specific inspection and testing shall be subjected to a non-destructive test (NDT) (see 9.4).

6.10 Tolerances and mass

6.10.1 Tolerances

Tolerances for hot-finished structural hollow sections shall be as specified in ISO 12633-2.

6.10.2 Mass

Mass shall be determined using a density of 7,85 kg/dm³.

NOTE Dimensions, sectional properties and mass per unit length for a range of standard sizes of hot-finished structural hollow sections are given in ISO 12633-2. The purchaser should preferably select the dimensions of the hollow sections from this range of standard sizes.

7 Inspection

7.1 Types of inspection and testing

7.1.1 Hollow sections of non-alloy steels in qualities JR and J0 (see Annex A) shall be subjected to non-specific inspection and testing in accordance with ISO 404 unless otherwise specified by the purchaser at the time of enquiry and order.

Option 9 (see 5.2): the purchaser may request specific inspection and testing at the time of enquiry and order.

7.1.2 Hollow sections of non-alloy steel quality J2 (see Annex A) and fine grain steels of qualities N and NL (see Annex B) shall be subjected to specific inspection and testing in accordance with ISO 404.

7.2 Types of inspection documentation

7.2.1 For products supplied with non-specific inspection and testing, a test report (see ISO 10474:1991, 2.2) in accordance with ISO 10474 shall be provided.

The test report shall contain the following information:

- a) commercial transactions and parties involved;
- b) description of products to which the test report applies;
- c) information on tests as follows:
 - 1) tensile test reports;
 - 2) chemical composition: a cast analysis;
- d) authentication.

7.2.2 For products supplied with specific inspection and testing, an inspection certificate (i.e. type "3.1.A", "3.1.B" or "3.1.C" as specified in ISO 10474:1991, 3.1,) or an inspection report ("3.2" as specified in ISO 10474:1991, 3.2) in accordance with ISO 10474, shall be provided.

The purchaser shall indicate in the enquiry and order the type of inspection document required [see 5.1 g)].

If an inspection document 3.1.A, 3.1.C or 3.2 is specified, the purchaser should notify the manufacturer of the address of the organization or person who is to carry out the inspection and produce the inspection document. In the case of the inspection report 3.2, it shall be agreed which party is to issue the certificate.

The inspection certificate or inspection report shall contain the following information:

- a) commercial transactions and parties involved;
- b) description of products to which the inspection document applies;
- c) information on tests as follows:
 - 1) tensile test: test piece shape and test results;
 - 2) impact test: test piece type and test results;
 - 3) the cast analysis and, if applicable, the product analysis;
- d) authentication.

7.3 Inspection and testing

7.3.1 General

The requirements for inspection and testing are given in Table 2 for hollow sections of non-alloy steels and in Table 3 for hollow sections of fine grain steels.

7.3.2 Non-specific inspection and testing

When products are supplied with non-specific inspection and testing, the tests shall be carried out by the manufacturer, in accordance with the manufacturer's own procedures, to demonstrate that products made by the same manufacturing process meet the requirements of the order. The products tested may not necessarily be the products actually supplied.

7.3.3 Specific inspection and testing

When products are supplied with specific inspection and testing, the tests shall be carried out on the products to be supplied, or on test units of which the product to be supplied is a part, or (when applicable) on all hollow sections.

Table 2 — Inspection and test programme for non-alloy steel hollow sections

| Inspection and test requirements | | | | Scope of inspection and test programme and type of document | |
|--|---|--|--------------------|---|---|
| Requirement | | Subclause reference(s) | | Non-specific inspection and testing | Specific inspection and testing |
| | | | | Test report ^a | Inspection certificate (type 3.1.A, 3.1.B or 3.1.C) ^b Inspection report (type 3.2) ^b |
| Mandatory requirements | 1 | Cast analysis | 6.5 9.1 | One result per delivery item | One per cast |
| | 2 | Tensile test | 6.6 9.2 | One result per delivery item | One per test unit ^{de} |
| | 3 | Impact test quality J2 only | 6.6 9.2 | Not applicable | One per test unit ^{de} |
| | 4 | Surface condition and dimensions | 6.8 6.10 9.3 | See 9.3 | See 9.3 |
| | 5 | NDT of the weld | 6.9 9.4 | Not applicable | All products, full length |
| Optional requirements | 6 | Product analysis | 6.5 9.1 | Not applicable | One per test unit |
| | 7 | Cast analysis additional elements | 6.5 9.1 | Not applicable | See option 3 |
| | 8 | Impact test (qualities JR and J0 only) | 6.6 9.2 | Not applicable | One per test unit ^{de} (only when option 6 is requested) |
| ^a In accordance with ISO 10474:1991, 2.2. ^b In accordance with ISO 10474:1991, 3.1. ^c In accordance with ISO 10474:1991, 3.2. ^d For test unit, see 8.1.3. ^e Longitudinal or transverse samples at the discretion of the manufacturer. | | | | | |

Table 3 — Inspection and test programme for fine grain steel hollow sections

| Inspection and test requirements | | | | Scope of inspection and test programme and type of document |
|----------------------------------|---|----------------------------------|---|---|
| Requirement | | Subclause reference(s) | Specific inspection and testing | |
| | | | Inspection certificate (3.1.A, 3.1.B or 3.1.C) ^a Inspection report (3.2) ^b | |
| Mandatory requirements | 1 | Cast analysis | 6.5 9.1 | One per cast |
| | 2 | Tensile test | 6.6 9.2 | One per test unit ^{cd} |
| | 3 | Impact test | 6.6 9.2 | One per unit ^{cd} |
| | 4 | Surface condition and dimensions | 6.8 6.10 9.3 | See 9.3 |
| | 5 | NDT of the weld | 6.9 9.4 | All products, full length |
| Optional requirements | 6 | Product analysis | 6.5 9.1 | One per test unit ^c |

^a In accordance with ISO 10474:1991, 3.1.
^b In accordance with ISO 10474:1991, 3.2.
^c For test unit, see 8.1.3.
^d Longitudinal or transverse samples at discretion of the manufacturer.

8 Samples

8.1 Frequency of tests

8.1.1 For products supplied with non-specific inspection and testing, see 7.3.2.

8.1.2 For products supplied with specific inspection and testing, the verification of the mechanical properties and product analysis, if applicable, shall be carried out by test unit. A test unit is defined as a quantity of hollow sections from one or more cast(s) of the same grade and dimensions manufactured by the same process (e.g. electric welding, submerged arc welding), and if applicable in the same heat treatment condition, submitted for acceptance at the same time.

From each test unit one sample shall be taken sufficient for the preparation of the following test pieces:

- one tensile test piece;
- two sets of three impact test pieces;
- one product analysis when required.

8.1.3 The test unit shall consist of the tonnage of sections as specified in Table 4.

Table 4 — Test units

| Type of section | | Test unit |
|------------------------------------|--------------------------|-----------|
| Circular | Square or rectangular | |
| Outside diameter <i>D</i> mm | External perimeter mm | Mass t |
| ≤ 114,3 | ≤ 400 | ≤ 40 |
| > 114,3, ≤ 323,9 | > 400, ≤ 800 | ≤ 50 |
| > 323,9 | > 800 | ≤ 75 |

8.2 Preparation of samples and test pieces

8.2.1 Selection and preparation of samples for chemical analysis

Samples for product analysis shall be taken from the test pieces or samples for mechanical testing or taken from the whole thickness of the hollow section at the same location as for the mechanical test samples. The preparation of samples shall be in accordance with ISO 14284.

8.2.2 Location and orientation of samples for mechanical tests

8.2.2.1 Tensile test pieces

The test pieces for tensile testing shall comply with the following.

- For circular, rectangular or square sections, the test piece may be the full section of the product.
- For circular sections, not tested in full section, the test pieces shall be taken longitudinally and shall be taken at a point remote from the weld (see Annex C).

Alternatively, at the discretion of the manufacturer, transverse test pieces may be taken.

- For square or rectangular sections, not tested in full section, the test pieces shall be taken longitudinally, midway between the corners, from one of the sides not containing the weld (see Annex C).

Alternatively, at the discretion of the manufacturer, transverse test pieces may be taken.

8.2.2.2 Impact test pieces

Test pieces for impact testing shall comply with the following.

- For circular sections the test pieces shall be taken longitudinally and shall be taken at a point remote from the weld (see Annex C).

Alternatively, at the discretion of the manufacturer, transverse test pieces may be taken.

- For square or rectangular sections the test pieces shall be taken longitudinally, midway between the corners, from one of the sides not containing the weld (see Annex C).

Alternatively, at the discretion of the manufacturer, transverse test pieces may be taken.

8.2.3 Preparation of test pieces for mechanical tests

The requirements of ISO 377 shall apply in conjunction with the test piece location specified in 8.2.2.

8.2.3.1 Tensile test pieces

The requirements of ISO 6892-1 and ISO 6892-2, as appropriate, shall apply.

Test pieces may be non-proportional but in cases of dispute proportional test pieces having a gauge length $L_0 = 5,65\sqrt{S_0}$ shall be used (see 9.2.2).

8.2.3.2 Impact test pieces

Impact V-notch test pieces shall be machined and prepared in accordance with ISO 148-1. In addition, the following requirements apply:

- a) for nominal thicknesses > 12 mm, standard test pieces shall be machined in such a way that one side is not further away than 2 mm from a rolled surface;
- b) for nominal thicknesses ≤ 12 mm, when test pieces with reduced sections are used, the width shall be ≥ 5 mm.

NOTE Test piece size is dependent on the actual thickness of the sample and, for circular hollow sections, allowance also needs to be made for the curvature of the section.

9 Test methods

9.1 Chemical analysis

The elements to be determined and reported shall be those given in Table A.1, unless option 3 is requested (see 5.2) or in Table B.1.

The choice of a suitable physical or chemical analytical method for the analysis shall be at the discretion of the manufacturer.

In case of dispute, the method used shall be agreed taking into account the relevant existing International Standards.

9.2 Mechanical tests

9.2.1 Temperature requirements

Tensile tests shall be carried out in the temperature range 10 °C to 35 °C. Impact tests shall be carried out at the temperatures specified in Table A.3 for non-alloy steels and Table B.3 for fine grain steels.

9.2.2 Tensile tests

The tensile test shall be carried out in accordance with ISO 6892-1 and ISO 6892-2.

For the specified yield strength in Tables A.3 and B.3, the upper yield strength (R_{eH}) shall be determined.

If a yield phenomenon is not present, the 0,2 % proof strength ($R_{p0,2}$) or the 0,5 % proof stress total elongation ($R_{t0,5}$) shall be determined. In cases of dispute, the 0,2 % proof strength ($R_{p0,2}$) shall apply.

If a non-proportional test piece is used, the percentage elongation value obtained shall be converted to the value for a gauge length $L_0 = 5,65\sqrt{S_0}$ using the conversion tables given in ISO 2566-1.

9.2.3 Impact tests

The impact test shall be carried out in accordance with ISO 148-1 and shall be assessed in accordance with ISO 404 as follows:

- a) the averaged value of a set of three test pieces shall meet the specified requirement. One individual value may be below the specified value, provided it is not less than 70 % of that value;
- b) if the conditions under a) are not satisfied then an additional set of three test pieces shall be taken from the same sample and tested. To consider the test unit as conforming, after testing the second set, the following conditions shall be satisfied simultaneously:
 - 1) the average value of six tests shall be equal to or greater than the specified value;
 - 2) not more than two of six individual values may be lower than the specified value;
 - 3) not more than one of the six individual values may be lower than 70 % of the specified value;
- c) if these conditions are not satisfied, the sample product is deemed not to comply with this part of ISO 12633 and retests may be carried out on the remainder of the test unit (see 9.5).

9.3 Visual examination and dimensional inspection

9.3.1 Visual examination

The hollow sections shall be visually examined for compliance with the requirements of 6.8.

9.3.2 Dimensional inspection

The dimensions of the hollow sections shall be inspected for compliance with the requirements of ISO 12633-2.

9.4 Non-destructive testing

9.4.1 General

When the welds of welded structural hollow sections are to be subjected to NDT, the method shall be in accordance with 9.4.2 or 9.4.3. At the manufacturer's discretion, the NDT may be carried out either on the circular shape prior to final forming or on the round, square or rectangular hollow sections after final forming.

9.4.2 Electric welded sections

The weld seam shall be tested in accordance with one of the following International Standards:

- a) ISO 10893-2 to acceptance level E5, with the exception that the rotating tube/pancake coil technique shall not be permitted.
- b) ISO 10893-3 or ISO 10893-11, with the exceptions that the acceptance level shall be based on the use of N 15 internal/external notches and that for the application of ISO 10893-3 a notch width of not greater than twice the depth of the reference notch with a maximum of 1,0 mm shall apply.

The International Standard to be applied is at the discretion of the manufacturer.

9.4.3 Submerged arc welded sections

The weld seam shall be tested to level U5 in accordance with ISO 10893-11 or by radiography in accordance with ISO 10893-6 with an image quality class B.

Butt welds used to join lengths of strip/plate together in the helically submerged arc weld process shall be permitted, provided the butt weld is tested to the same type of procedure and meets the same acceptance level as the main weld seam.

9.5 Retests, sorting and reprocessing

For retests, sorting and reprocessing, ISO 404 shall apply.

10 Marking

10.1 Except as provided for in 10.2 for bundled hollow sections, each hollow section shall be marked by suitable and durable methods, such as painting, stamping, adhesive labels or attached tags with the following:

- the abridged designation, e.g. ISO 12633-1 - S275J0 (but see also 6.4 for special delivery conditions);
- the manufacturer's name or trademark;
- in the case of specific inspection and testing, an identification number, e.g. order item number, which permits the correlation of the product or delivery unit to the related inspection document.

EXAMPLES

ISO 12633-1 - S235JR + trademark

ISO 12633-1 - S275NL + manufacturer's name + order item number

10.2 Where the products are supplied bundled, the marking required in 10.1 may be on a label, which shall be securely attached to the bundle.

Annex A (normative)

Structural hollow sections of non-alloy steels — Chemical composition and mechanical properties

Table A.1 — Chemical composition — Cast analysis for product thickness less than or equal to 65 mm

| Steel grade | Type of deoxidation ^a | C % max. | | Si % | Mn % | P % | S % | N % |
|-------------|----------------------------------|-------------------------|------------|---------|---------|--------|--------|--------------------|
| | | Nominal thickness mm | | | | | | |
| | | ≤ 40 | > 40, ≤ 65 | max. | max. | max. | max. | max. ^{bc} |
| S235JRH | FN | 0,17 | 0,20 | — | 1,40 | 0,045 | 0,045 | 0,009 |
| S275J0H | FN | 0,20 | 0,22 | — | 1,50 | 0,040 | 0,040 | 0,009 |
| S275J2H | FF | 0,20 | 0,22 | — | 1,50 | 0,035 | 0,035 | — |
| S355J0H | FN | 0,22 | 0,22 | 0,55 | 1,60 | 0,040 | 0,040 | 0,009 |
| S355J2H | FF | 0,22 | 0,22 | 0,55 | 1,60 | 0,035 | 0,035 | — |

^a The deoxidation methods are designated as follows:
 FN: Rimming steel not permitted;
 FF: Fully killed steel containing nitrogen-binding elements in amounts sufficient to bind available nitrogen (e.g. min. 0,020 % total Al, or 0,015 % soluble Al).

^b It is permissible to exceed the specified values, provided for each increase of 0,001 % N, the maximum P content is reduced by 0,005 %; the N content of the cast analysis, however, shall not be more than 0,012 %.

^c The maximum value for nitrogen does not apply if the chemical composition shows a minimum total Al content of 0,020 %, with a minimum Al/N ratio of 2:1, or if sufficient other nitrogen-binding elements are present. The nitrogen-binding elements shall be mentioned in the inspection document.

Table A.2 — Maximum carbon equivalent value based on cast analysis

| Steel grade | Maximum CEV % | | |
|-------------|-------------------------|------------|------------|
| | Nominal thickness mm | | |
| | ≤ 16 | > 16, ≤ 40 | > 40, ≤ 65 |
| S235JRH | 0,37 | 0,39 | 0,41 |
| S275J0H | 0,41 | 0,43 | 0,45 |
| S275J2H | 0,41 | 0,43 | 0,45 |
| S355J0H | 0,45 | 0,47 | 0,50 |
| S355J2H | 0,45 | 0,47 | 0,50 |

Table A.3 — Mechanical properties for non-alloy structural steel hollow sections

| Steel grade | Upper yield strength R_{eH} N/mm ² | | | Tensile strength R_m N/mm ² | | Minimum percentage elongation A_{min} $L_0 = 5,65\sqrt{S_0}$ | | | | Impact properties | |
|----------------------|---|------------|------------|--|------------|---|------------|------------|------------|------------------------|--|
| | | | | | | Longitudinal | | Transverse | | Test temperature °C | Minimum average absorbed energy for standard test pieces ^b J |
| | Nominal thickness mm | | | Nominal thickness mm | | Nominal thickness mm | | | | | |
| | ≤ 16 | > 16, ≤ 40 | > 40, ≤ 65 | < 3 | ≥ 3, ≤ 65 | ≤ 40 | > 40, ≤ 65 | ≤ 40 | > 40, ≤ 65 | | |
| S235JRH ^a | 235 | 225 | 215 | 360 to 510 | 340 to 470 | 26 | 25 | 24 | 23 | 20 | 27 |
| S275J0H ^a | 275 | 265 | 255 | 430 to 580 | 410 to 560 | 22 | 21 | 20 | 19 | 0 | 27 |
| S275J2H | | | | | | | | | | -20 | 27 |
| S355J0H ^a | 355 | 345 | 335 | 510 to 680 | 490 to 630 | 22 | 21 | 20 | 19 | 0 | 27 |
| S355J2H | | | | | | | | | | -20 | 27 |

^a The impact properties are verified only when specified at the time of enquiry and order for products supplied with specific inspection and testing.

^b For impact properties for reduced section test pieces, see 6.6.2.

Annex B (normative)

Structural hollow sections of fine grain steels — Chemical composition and mechanical properties

Table B.1 — Chemical composition — Cast analysis for product thickness less than or equal to 65 mm

| Steel grade | Type of deoxidation ^a | C | Si | Mn | P | S | Nb | V | Al | Ti | Cr | Ni | Mo | Cu | N |
|-------------|----------------------------------|-----------|-----------|--------------|-----------|-----------|-----------|-----------|-----------|------------------------------|-----------|-----------|-----------|-----------|------------------------|
| | | % max. | % max. | % max. | % max. | % max. | % max. | % max. | % max. | Total % min. ^b | % max. | % max. | % max. | % max. | % max. ^c |
| S275NH | GF | 0,20 | 0,40 | 0,50 to 1,40 | 0,035 | 0,030 | 0,050 | 0,05 | 0,020 | 0,03 | 0,30 | 0,30 | 0,10 | 0,35 | 0,015 |
| S275NLH | | | | | 0,030 | 0,025 | | | | | | | | | |
| S355NH | GF | 0,20 | 0,50 | 0,90 to 1,65 | 0,035 | 0,030 | 0,050 | 0,12 | 0,020 | 0,03 | 0,30 | 0,50 | 0,10 | 0,35 | 0,015 |
| S355NLH | | 0,18 | | | 0,030 | 0,025 | | | | | | | | | |
| S460NH | GF | 0,20 | 0,60 | 1,00 to 1,70 | 0,035 | 0,030 | 0,050 | 0,20 | 0,020 | 0,03 | 0,30 | 0,80 | 0,10 | 0,70 | 0,025 |
| S460NLH | | | | | 0,030 | 0,025 | | | | | | | | | |

^a The deoxidation method is designated as follows:
GF = Fully killed steel containing nitrogen-binding elements in sufficient amounts to bind the available nitrogen and having a fine grain structure.

^b If sufficient nitrogen-binding elements are present, the minimum total Al content does not apply.

^c If the copper content is greater than 0,30 %, the nickel content shall be at least half of the copper content.

Table B.2 — Maximum carbon equivalent value based on cast analysis

| Steel grade | Type of deoxidation | Maximum CEV % | |
|----------------------|---------------------|----------------------|------------|
| | | Nominal thickness mm | |
| | | ≤ 16 | > 16, ≤ 65 |
| S275NH | GF | 0,40 | 0,40 |
| S275NLH | | | |
| S355NH | GF | 0,43 | 0,45 |
| S355NLH | | | |
| S460NH ^a | GF | — | — |
| S460NLH ^a | | | |

^a See 6.5.3, option 5.

Table B.3 — Mechanical properties

| Steel grade | Upper yield strength R_{eH} N/mm ² | | | Tensile strength R_m N/mm ² | Minimum percentage elongation A_{min} $L_0 = 5,65\sqrt{S_0}$ | | Impact properties | |
|-------------|---|---------------|---------------|--|--|------------|------------------------|--|
| | | | | | Longitudinal | Transverse | | |
| | Nominal thickness mm | | | | Nominal thickness mm | | Test temperature °C | Minimum average absorbed energy for standard test pieces ^a J |
| | ≤ 16 | > 16, ≤ 40 | > 40, ≤ 65 | ≤ 65 | | | | |
| S275NH | 275 | 265 | 255 | 370 to 540 | 24 | 22 | -20 | 40 |
| S275NLH | | | | | | | -50 | 27 |
| S355NH | 355 | 345 | 335 | 470 to 630 | 22 | 20 | -20 | 40 |
| S355NLH | | | | | | | -50 | 27 |
| S460NH | 460 | 440 | 430 | 550 to 720 | 17 | 15 | -20 | 40 |
| S460NLH | | | | | | | -50 | 27 |

^a For impact properties for reduced section test pieces, see 6.6.2.

www.iso.org/iso/12633-1

Annex C (normative)

Location of samples and test pieces for hollow sections

C.1 Location of samples

C.1.1 General

This annex gives information on the location of samples and test pieces for hollow sections (see 8.2.2).

C.1.2 Location of samples for tensile test

See Figures C.1 to C.3.

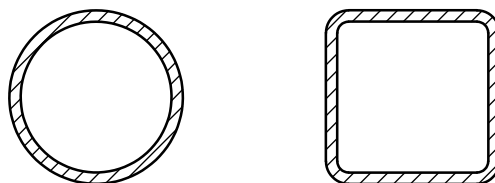

For circular, rectangular or square sections, the test piece may be the full section of the product.

Figure C.1 — Small sections

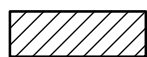
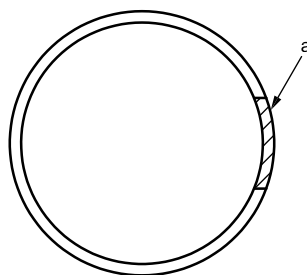

location of samples

^a At any point on circumference, but in the case of welded sections, remote from the weld.

Figure C.2 — Circular sections

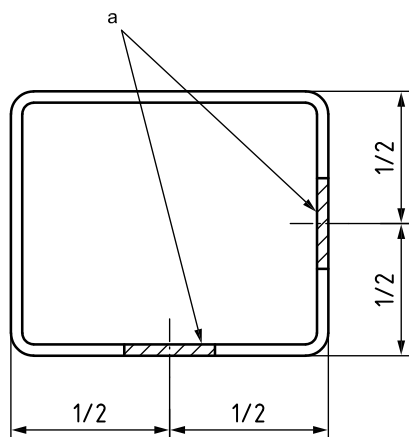

 location of samples

^a Alternative positions (on any side except a side containing the weld in welded sections).

Figure C.3 — Square and rectangular sections

C.1.3 Location of test samples for impact test

See Figures C.4 and C.5.

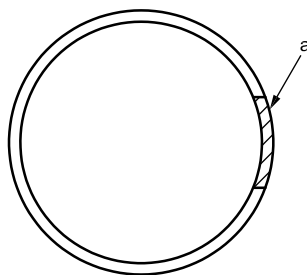

 location of samples

^a At any point on circumference, but in the case of welded sections, remote from the weld.

Figure C.4 — Circular section

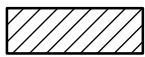
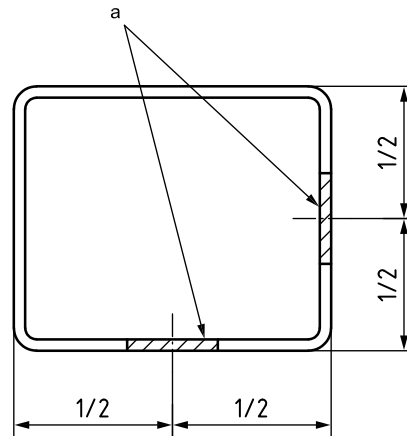

location of samples

- a Alternative positions (on any side except, in welded sections, a side containing the weld).

Figure C.5 — Square and rectangular sections

C.2 Test pieces

Test pieces are taken from the samples indicated in Figures C.1 to C.5.

Bibliography

- [1] ISO 630-1, *Structural steels — Part 1: General technical delivery conditions for hot-rolled products*¹⁾
- [2] ISO 630-2, *Structural steels — Part 2: Technical delivery conditions for structural steels for general purposes*¹⁾
- [3] ISO/TS 4949, *Steel names based on letter symbols*
- [4] ISO 6929, *Steel products — Definitions and classification*
- [5] ISO 9001, *Quality management systems — Requirements*
- [6] ISO 10799-1, *Cold-formed welded structural hollow sections of non-alloy and fine grain steels — Part 1: Technical delivery conditions*
- [7] ISO 10799-2, *Cold-formed welded structural hollow sections of non-alloy and fine grain steels — Part 2: Dimensions and sectional properties*

1) To be published.

ICS 77.140.75

Price based on 24 pages