

---

---

**Thermal performance of curtain  
walling — Calculation of thermal  
transmittance**

*Performance thermique des façades-rideaux — Calcul du coefficient de  
transmission thermique*



Reference number  
ISO 12631:2012(E)

© ISO 2012



**COPYRIGHT PROTECTED DOCUMENT**

© ISO 2012

All rights reserved. Unless otherwise specified, no part of this publication may be reproduced or utilized in any form or by any means, electronic or mechanical, including photocopying and microfilm, without permission in writing from either ISO at the address below or ISO's member body in the country of the requester.

ISO copyright office  
Case postale 56 • CH-1211 Geneva 20  
Tel. + 41 22 749 01 11  
Fax + 41 22 749 09 47  
E-mail [copyright@iso.org](mailto:copyright@iso.org)  
Web [www.iso.org](http://www.iso.org)

Published in Switzerland

# Contents

Page

Foreword .....	iv
Introduction.....	v
<b>1 Scope .....</b>	<b>1</b>
<b>2 Normative references .....</b>	<b>1</b>
<b>3 Terms, definitions, symbols and units .....</b>	<b>2</b>
<b>3.1 Terms and definitions .....</b>	<b>2</b>
<b>3.2 Symbols and units.....</b>	<b>3</b>
<b>3.3 Subscripts .....</b>	<b>3</b>
<b>3.4 Superscripts.....</b>	<b>4</b>
<b>4 Geometrical characteristics .....</b>	<b>4</b>
<b>4.1 Main principles .....</b>	<b>4</b>
<b>4.2 Internal depth.....</b>	<b>6</b>
<b>4.3 Boundaries of curtain wall structures.....</b>	<b>6</b>
<b>5 Cut-off planes and partitioning of thermal zones .....</b>	<b>9</b>
<b>5.1 Rules for thermal modelling.....</b>	<b>9</b>
<b>5.2 Cut-off planes of the geometrical model.....</b>	<b>9</b>
<b>6 Calculation of curtain wall transmittance .....</b>	<b>9</b>
<b>6.1 Methodologies .....</b>	<b>9</b>
<b>6.2 Single assessment method .....</b>	<b>10</b>
<b>6.3 Component assessment method.....</b>	<b>16</b>
<b>6.4 Thermal transmittance of a curtain wall built of different elements .....</b>	<b>21</b>
<b>7 Input data .....</b>	<b>21</b>
<b>8 Report .....</b>	<b>22</b>
<b>8.1 Section drawings.....</b>	<b>22</b>
<b>8.2 Overview drawing of the whole curtain wall element .....</b>	<b>23</b>
<b>8.3 Values used for calculation.....</b>	<b>23</b>
<b>8.4 Presentation of results.....</b>	<b>23</b>
<b>Annex A (informative) Guidance for calculating the thermal transmittance <math>U_{CW}</math> of curtain walling using the two methods .....</b>	<b>24</b>
<b>Annex B (informative) Linear thermal transmittance of junctions.....</b>	<b>25</b>
<b>Annex C (normative) A method for calculating the thermal effect of screws using a 2D numerical method and the procedures specified in ISO 10077-2:2012 .....</b>	<b>33</b>
<b>Annex D (normative) Ventilated and unventilated air spaces .....</b>	<b>36</b>
<b>Annex E (informative) Component method: Calculation example.....</b>	<b>39</b>
<b>Annex F (informative) Single assessment method: Calculation example .....</b>	<b>45</b>
<b>Annex G (normative) Parallel routes in normative references.....</b>	<b>48</b>
<b>Bibliography.....</b>	<b>49</b>

## Foreword

ISO (the International Organization for Standardization) is a worldwide federation of national standards bodies (ISO member bodies). The work of preparing International Standards is normally carried out through ISO technical committees. Each member body interested in a subject for which a technical committee has been established has the right to be represented on that committee. International organizations, governmental and non-governmental, in liaison with ISO, also take part in the work. ISO collaborates closely with the International Electrotechnical Commission (IEC) on all matters of electrotechnical standardization.

International Standards are drafted in accordance with the rules given in the ISO/IEC Directives, Part 2.

The main task of technical committees is to prepare International Standards. Draft International Standards adopted by the technical committees are circulated to the member bodies for voting. Publication as an International Standard requires approval by at least 75 % of the member bodies casting a vote.

Attention is drawn to the possibility that some of the elements of this document may be the subject of patent rights. ISO shall not be held responsible for identifying any or all such patent rights.

ISO 12631 was prepared by the European Committee for Standardization (CEN) Technical Committee CEN/TC 89, *Thermal performance of buildings and building components*, the secretariat of which is held by SIS, in collaboration with ISO Technical Committee TC 163, *Thermal performance and energy use in the built environment*, Subcommittee SC 2, *Calculation methods*, in accordance with the Agreement on technical cooperation between ISO and CEN (Vienna Agreement).

## Introduction

The design and construction of curtain wall systems is complex. This International Standard specifies a procedure for calculating the thermal transmittance of curtain wall structures.

Curtain walls often contain different kinds of materials, joined in different ways, and can exhibit numerous variations of geometrical shape. With such a complex structure, the likelihood of producing thermal bridges across the curtain wall envelope is quite high.

The results of calculations, carried out following the procedures specified in this International Standard, can be used for comparison of the thermal transmittance of different types of curtain wall or as part of the input data for calculating the heat used in a building. This International Standard is not suitable for determining whether or not condensation will occur on the structure surfaces nor within the structure itself.

Two methods are given in this International Standard:

- single assessment method (see 6.2);
- component assessment method (see 6.3).

Guidance on the use of these two methods is given in Annex A. Calculation examples for these two methods are given in Annex E and Annex F.

Testing according to ISO 12567-1:2010 is an alternative to this calculation method.

The thermal effects of connections to the main building structure as well as fixing lugs can be calculated according to ISO 10211:2007.

The thermal transmittance of the frame,  $U_f$ , is defined according to ISO 10077-2:2012 or EN 12412-2:2003 together with Annex A. The thermal transmittance of glazing units,  $U_g$ , is defined according to the documents listed in Table G.1 which does not include the edge effects. The thermal interaction of the frame and the filling element is included in the linear thermal transmittance  $\Psi$  which is derived using the procedures specified in ISO 10077-2:2012.

12/03/2013 08:56:38 MST

# Thermal performance of curtain walling — Calculation of thermal transmittance

## 1 Scope

This International Standard specifies a method for calculating the thermal transmittance of curtain walls consisting of glazed and/or opaque panels fitted in, or connected to, frames.

The calculation includes:

- different types of glazing, e.g. glass or plastic; single or multiple glazing; with or without low emissivity coating; with cavities filled with air or other gases;
- frames (of any material) with or without thermal breaks;
- different types of opaque panels clad with metal, glass, ceramics or any other material.

Thermal bridge effects at the rebate or connection between the glazed area, the frame area and the panel area are included in the calculation.

The calculation does not include:

- effects of solar radiation;
- heat transfer caused by air leakage;
- calculation of condensation;
- effect of shutters;
- additional heat transfer at the corners and edges of the curtain walling;
- connections to the main building structure nor through fixing lugs;
- curtain wall systems with integrated heating.

## 2 Normative references

The following referenced documents are indispensable for the application of this document. For dated references, only the edition cited applies. For undated references, the latest edition of the referenced document (including any amendments) applies.

ISO 6946:2007, *Building components and building elements — Thermal resistance and thermal transmittance — Calculation method*

ISO 7345:1987, *Thermal insulation — Physical quantities and definitions*

## ISO 12631:2012(E)

ISO 10077-1:2006, *Thermal performance of windows, doors and shutters — Calculation of thermal transmittance — Part 1: General*

ISO 10077-2:2012, *Thermal performance of windows, doors and shutters — Calculation of thermal transmittance — Part 2: Numerical method for frames*

ISO 10211:2007, *Thermal bridges in building construction — Heat flows and surface temperatures — Detailed calculations*

ISO 10291:1994, *Glass in building — Determination of steady-state U values (thermal transmittance) of multiple glazing - Guarded hot plate method*

ISO 10292:1994, *Glass in building — Calculation of steady-state U values (thermal transmittance) of multiple glazing*

ISO 10293:1997, *Glass in building — Determination of steady-state U values (thermal transmittance) of multiple glazing - Heat flow meter method*

ISO 12567-1:2010, *Thermal performance of windows and doors — Determination of thermal transmittance by hot box method — Part 1: Complete windows and doors*

EN 673:2011, *Glass in building — Determination of thermal transmittance (U value) — Calculation method*

EN 674:2011, *Glass in building — Determination of thermal transmittance (U value) — Guarded hot plate method*

EN 675:2011, *Glass in building — Determination of thermal transmittance (U value) — Heat flow meter method*

EN 12412-2:2003, *Thermal performance of windows, doors and shutters — Determination of thermal transmittance by hot-box method — Part 2: Frames*

## 3 Terms, definitions, symbols and units

### 3.1 Terms and definitions

For the purposes of this document, the terms and definitions given in ISO 7345:1987, ISO 6946:2007 and Annex G apply.

NOTE Clause 4 includes descriptions of a number of geometrical characteristics of glazing units, frame sections and panels.



### 3.2 Symbols and units

Table 1 — Symbols and units

Symbol	Quantity	Unit
$A$	area	$m^2$
$T$	thermodynamic temperature	K
$U$	thermal transmittance	$W/(m^2 \cdot K)$
$l$	length	m
$d$	depth	m
$\phi$	heat flow rate	W
$\psi$	linear thermal transmittance	$W/(m \cdot K)$
$\Delta$	difference	
$\Sigma$	summation	
$\varepsilon$	emissivity	

### 3.3 Subscripts

cw	curtain walling
d	developed
e	external
eq	equivalent
f	frame
f,g	frame/glazing
FE	filling element
g	glazing
i	internal
j	joint
m	mullion
m,f	mullion/frame
m,g	mullion/glazing
n	normal
p	panel (opaque)
s	screw
t	transom
t,f	transom/frame
t,g	transom/glazing
tot	total
TJ	thermal joint at a connection between two filling elements
W	window

### 3.4 Superscripts

\* definition of areas for length-related treatment of thermal joints (see 6.2.2.3)

## 4 Geometrical characteristics

### 4.1 Main principles

The main principles of curtain walling are shown in Figures 1 and 2.

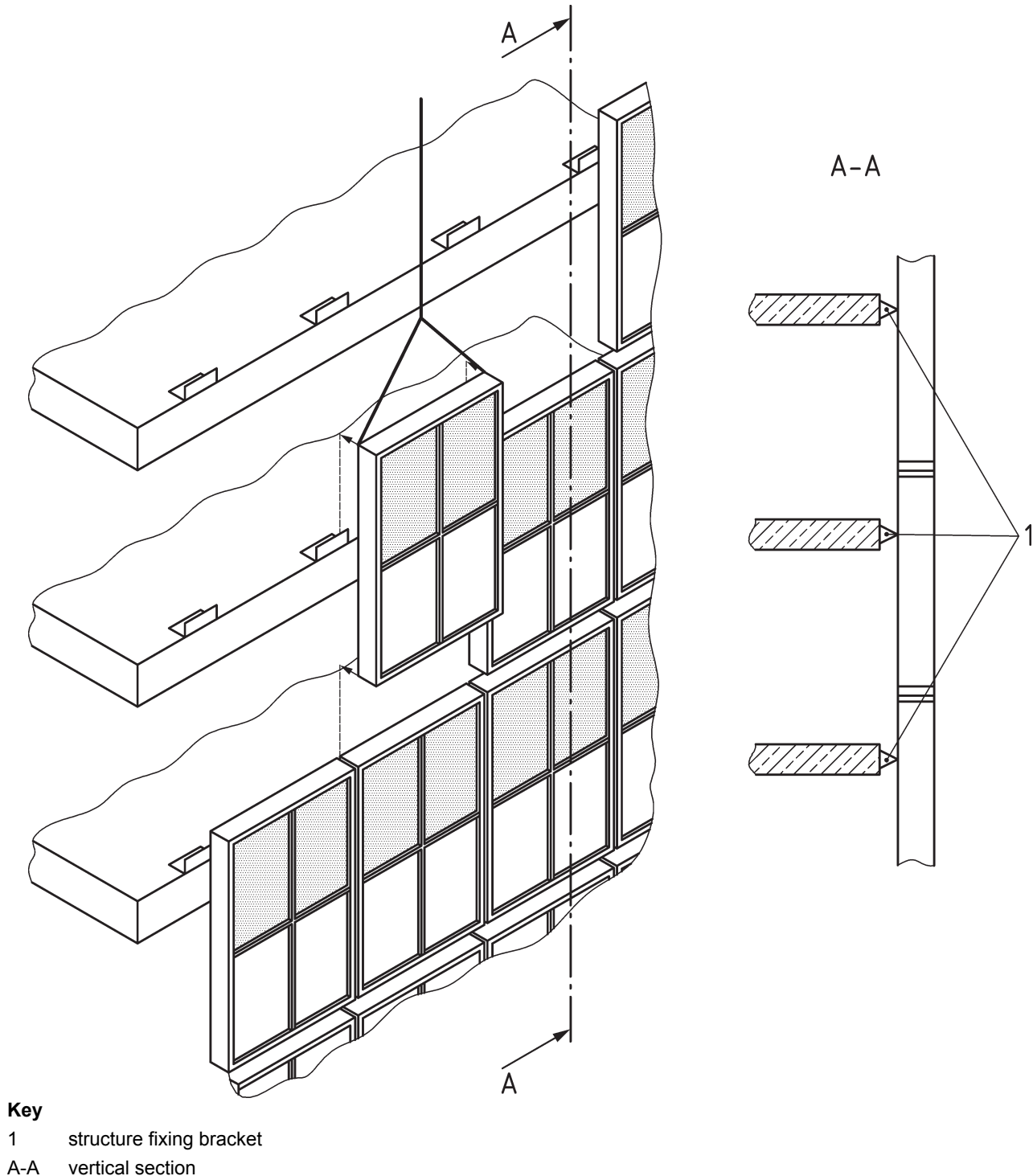

**Figure 1 — Principle of curtain walling construction: unitised construction**

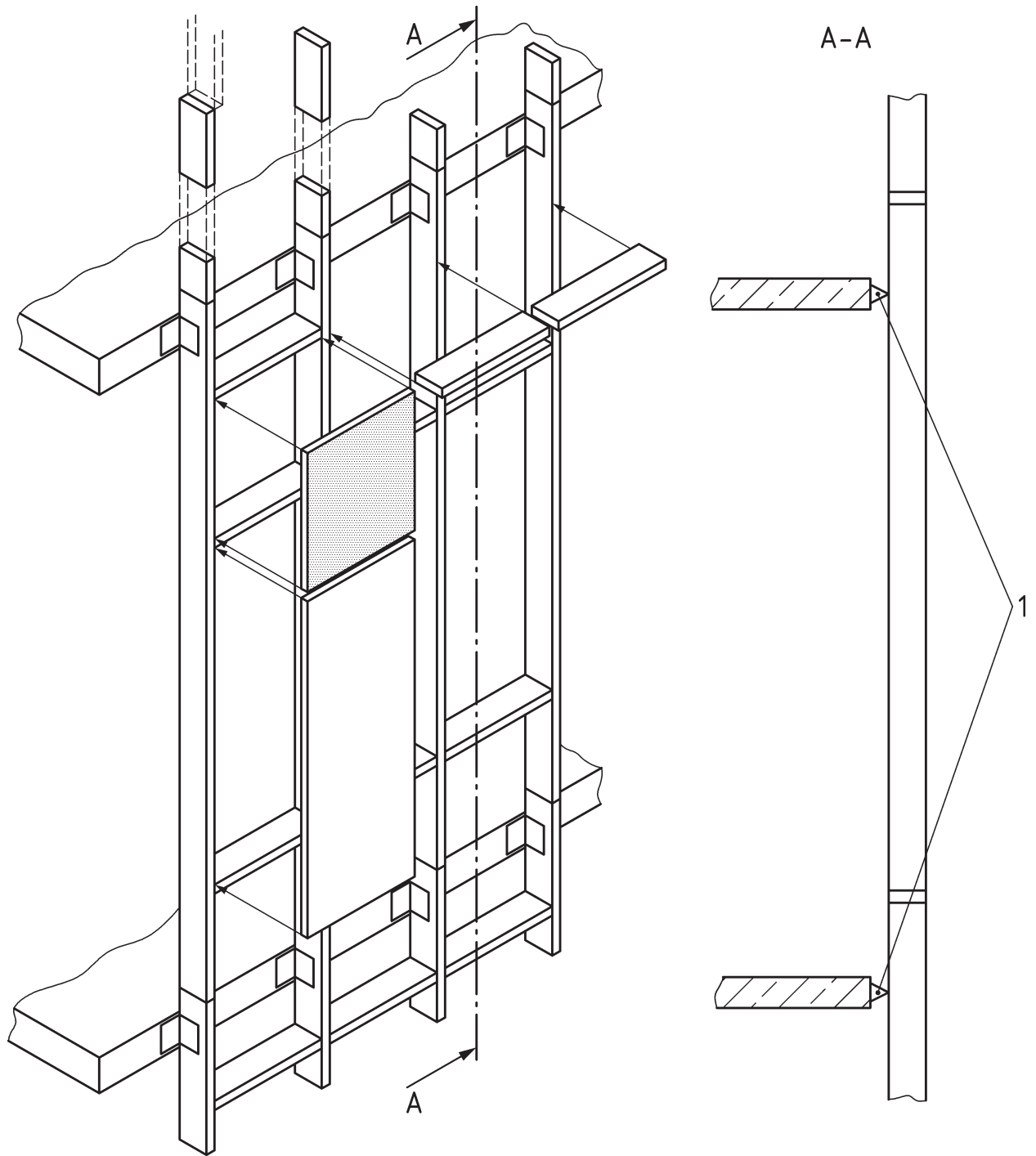

**Key**

- 1 structure fixing bracket
- A-A vertical section

**Figure 2 — Principle of curtain walling construction: stick construction**

## 4.2 Internal depth

The internal depth is defined as shown in Figure 3.

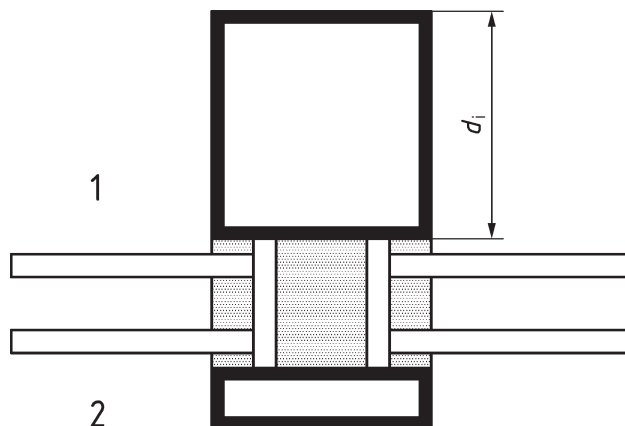

### Key

- 1 internal
- 2 external
- $d_i$  internal depth of mullion or transom

Figure 3 — Internal and external developed area, internal depth

## 4.3 Boundaries of curtain wall structures

### 4.3.1 General

To evaluate the thermal transmittance of façades, representative reference areas should be defined. The following subclauses define the various areas.

4.3.2 Boundaries of a representative reference element

The boundaries of the representative reference element shall be chosen according to the principles shown in Figure 4.

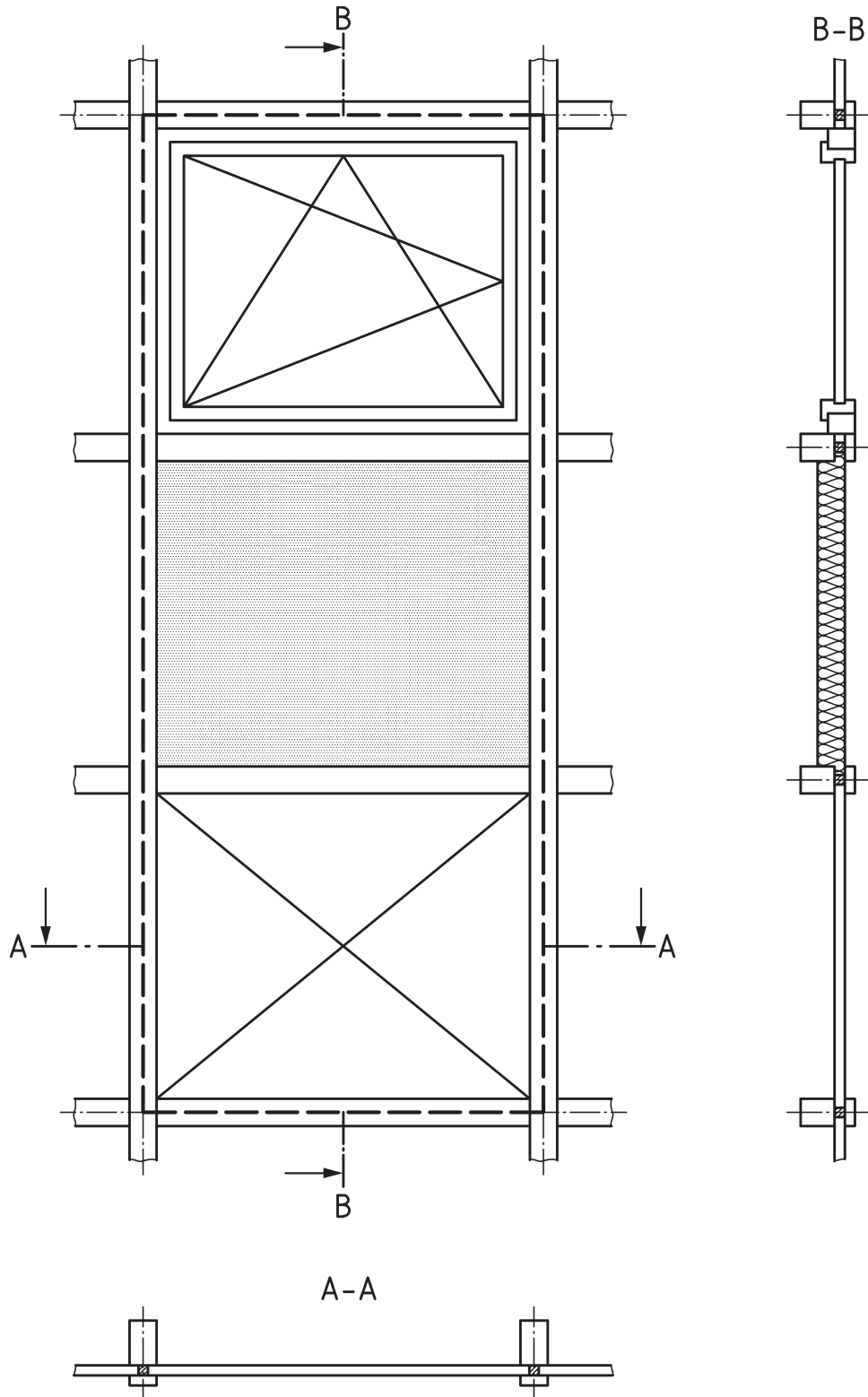

**Key**  
 - - - - - Boundaries of the representative element

Figure 4 — Boundaries of a representative reference element of a façade

4.3.3 Curtain wall areas

The representative reference element is divided into areas of different thermal properties (sash, frame, mullion, transom, glazing units and panel sections) as shown in Figure 5.

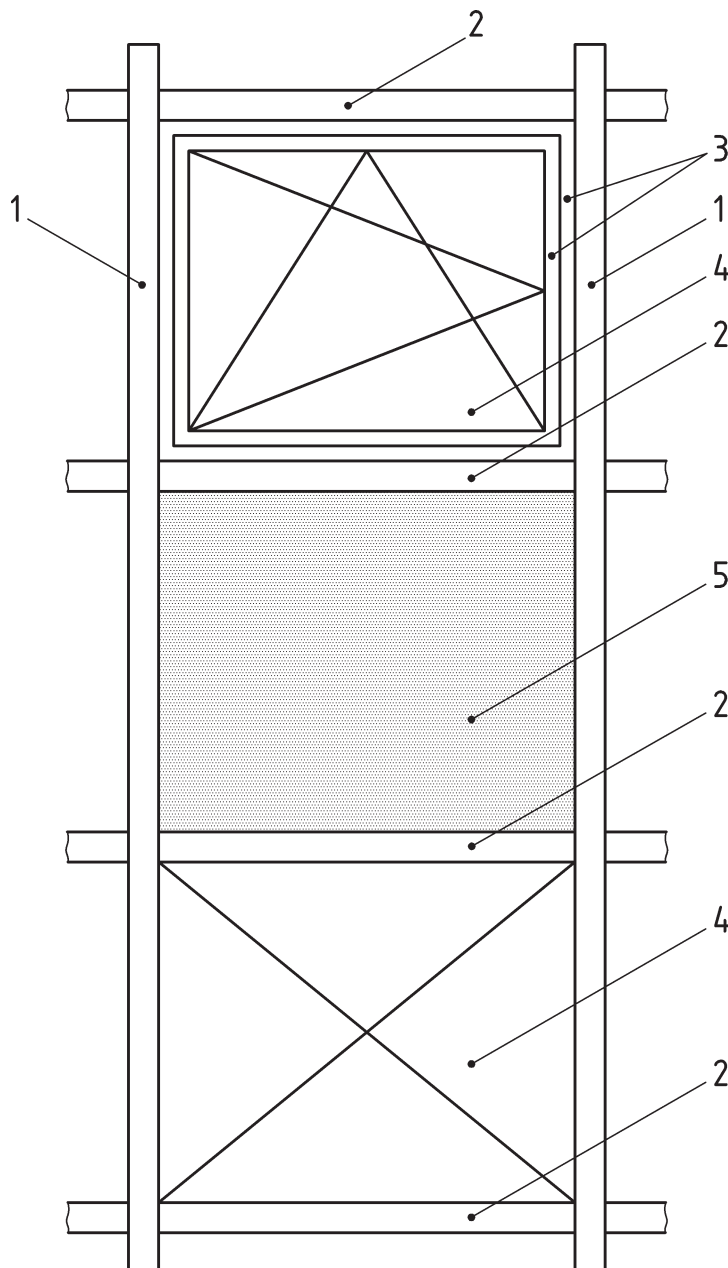

**Key**

- 1 mullion
- 2 transom
- 3 sash and frame
- 4 glazing
- 5 panel

**Figure 5 — Areas with different thermal properties**

## 5 Cut-off planes and partitioning of thermal zones

### 5.1 Rules for thermal modelling

In most cases, the façade can be partitioned into several sections by using cut-off planes so that the thermal transmittance of the overall façade can be calculated as the area-weighted average of the thermal transmittance of each section. The necessary input data (thermal properties of each section) can be evaluated by measurement, two-dimensional finite element or finite difference software calculation or by tables or diagrams. In general there are two possibilities:

- the single assessment method (see 6.2);
- the component assessment method (see 6.3).

The partitioning of the façade shall be performed in such a way as to avoid any significant differences in calculation results of the façade treated as a whole and the heat flow rate through the partitioned façade. Appropriate partitioning into several geometrical parts is achieved by choosing suitable cut-off planes.

### 5.2 Cut-off planes of the geometrical model

The geometrical model includes central elements (glazing units, spandrel panels etc.) and thermal joints (mullion, transom, silicone joint etc.), which connect the different central elements. The geometrical model is delimited by cut-off planes.

Curtain walling often contains highly conductive elements (glass and metals) which implies that significant lateral heat flow is possible. Cut-off planes shall represent adiabatic boundaries, which can be either:

- a symmetry plane, or
- a plane where the heat flow through that plane is perpendicular to the plane of the curtain wall, i.e. no edge effect is present (e.g. at least 190 mm away from the edge of a double glazing unit).

Cut-off planes may be positioned only where there is a clear adiabatic situation (i.e. the heat flow is perpendicular to the plane). Figure 6 shows adiabatic lines (in the middle of the glass or panel far enough from the frame) where the heat flow will be perpendicular to the glass panes.

Cut-off planes do not necessarily fall at the same place as the geometrical boundaries of a unitised element (i.e. through the frame). The middle of a frame might not be an adiabatic boundary. This might be due to asymmetric geometrical shape of the frame, asymmetric material properties (e.g. different conductivity of sub-components at each side of the frame), or asymmetric connection of panels in a symmetric frame (e.g. a frame that connects a spandrel panel and a glazing unit, or two glazing units with different thermal properties).

## 6 Calculation of curtain wall transmittance

### 6.1 Methodologies

Two methods of calculating the thermal transmittance of curtain wall systems are specified: the single assessment method and the component assessment method.

The single assessment method (see 6.2) is based on detailed computer calculations of the heat transfer through a complete construction including mullions, transoms, and filling elements (e.g. glazing unit, opaque panel). The heat flow rate (between two adiabatic lines) is calculated by modelling each thermal joint between two filling elements (opaque panel and/or glazing unit) using two-dimensional or three-dimensional finite element analysis software. By area weighting the  $U$ -values of thermal joints and filling elements, the overall façade  $U$ -value can be calculated. This method can be used for any curtain walling system (i.e. unitised systems, stick systems, patent glazing, structural sealant glazing, rain screens, structural glazing).

The component assessment method (see 6.3) divides the representative element into areas of different thermal properties, e.g. glazing units, opaque panels and frames. By area weighting the  $U$ -values of these elements with additional correction terms describing the thermal interaction between these elements ( $\Psi$ -values), the overall façade  $U$ -value can be calculated. This method can be used for curtain walling systems such as unitised systems, stick systems and patent glazing. Structural silicone glazing, rain screens and structural glazing are excluded from the component assessment method.

For the purposes of this International Standard, the term “filling element” is any façade component that has a one-dimensional heat flow in the absence of edge effects (the flat surface being perpendicular to the heat flow direction). Examples are glazing units and spandrel panels.

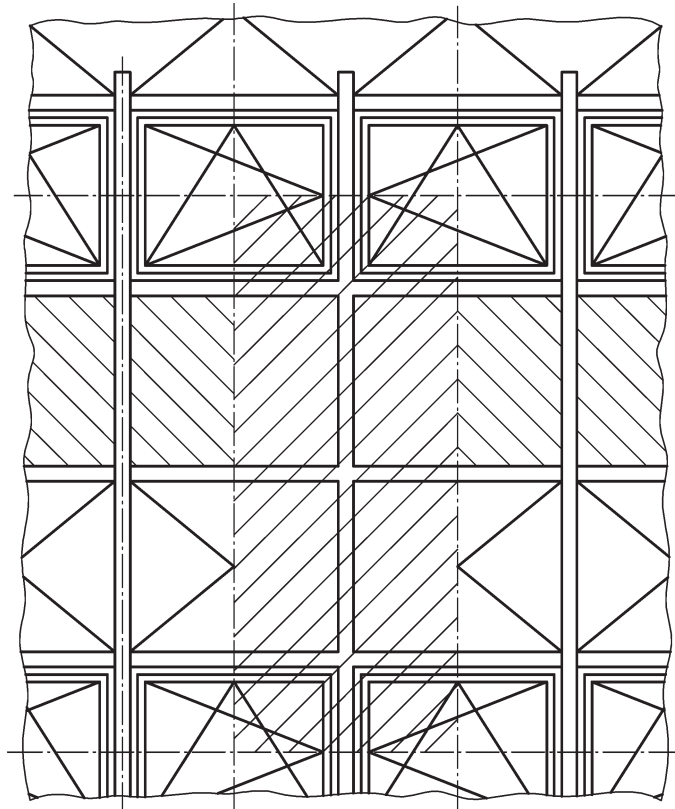

Figure 6 — Thermal section representing the full curtain wall

## 6.2 Single assessment method

### 6.2.1 Thermal transmittance of glazing units and panels (filling elements)

The thermal transmittance of opaque panels  $U_p$  shall be evaluated according to ISO 6946:2007. The thermal transmittance of glazing units  $U_g$  shall be evaluated according to the documents listed in Table G.1. In some cases, there is a different filling element at each side of the thermal joint (mullion, transom), so that two thermal transmittances have to be determined.

### 6.2.2 Determination of the heat flow through filling element / mullion or transom / filling element connection

#### 6.2.2.1 General

The total heat flow rate  $\Phi_{tot}$  of the complete connection shall be calculated using computer software that conforms to ISO 10211:2007 and ISO 10077-2:2012 or measured according to ISO 12567-1:2010 with the



filling elements positioned between the adiabatic lines. The modelling of screws (if present) in the two dimensional calculation shall be performed according to Annex C.

Since the heat flow rate is determined between the two adiabatic boundaries, it represents the heat flow through the filling elements, the thermal joint (e.g. mullion/transom) and also the lateral heat flow (edge effects) of the interaction between the two filling elements.

Therefore,  $\Phi_{\text{tot}}$  represents the total heat flow rate that results from making a thermal joint between two filling elements and includes:

- heat flow rate straight through filling element 1 and filling element 2 (one dimensional heat flow perpendicular to the surface of the filling element);
- heat flow rate through the thermal joint that is used to connect the two filling elements together (e.g. a frame in a framed curtain wall, a silicone joint in case of structural glazing);
- lateral and edge heat-flows due to the thermal interaction between the filling elements and the thermal joint and due to the edge constructions of the two individual filling elements (e.g. glass spacer).

As in most cases these different heat flows are difficult to separate, and to assign to a specific sub-component of the thermal joint, it is appropriate to split the overall heat flow through a thermal joint into only three parts (see Figure 7a):

- the heat flow rate  $\Phi_{\text{FE1}}$  through filling element 1 without the presence of the thermal joint (i.e. the heat flow derived from the centre  $U$ -value of filling element 1);
- the heat flow rate  $\Phi_{\text{FE2}}$  through filling element 2 without the presence of the thermal joint (i.e. the heat flow derived from the centre  $U$ -value of filling element 2);
- the heat flow rate  $\Phi_{\text{TJ}}$  which is the additional heat flow rate due to making a thermal joint (which includes direct and lateral heat flows of all joint edges and the thermal joint itself excluding the one dimensional heat flow through the filling elements).

There are two ways of allowing for the additional heat flow rate  $\Phi_{\text{TJ}}$ , which are equivalent and either approach will yield the same result for the thermal transmittance of the curtain wall. The possibilities are:

- consider the heat flow rate  $\Phi_{\text{TJ}}$  in terms of an area-related joint thermal transmittance  $U_{\text{TJ}}$ ;
- consider the heat flow rate  $\Phi_{\text{TJ}}$  in terms of a length-related linear joint thermal transmittance  $\Psi_{\text{TJ}}$ .

The thermal transmittance of the joint  $U_{\text{TJ}}$  or the linear thermal transmittance of the joint  $\Psi_{\text{TJ}}$  includes, in one single parameter, all thermal bridging effects resulting from making a thermal joint between the filling elements. This definition should not be compared with the frame thermal transmittance  $U_f$  (e.g. as defined in ISO 10077-2:2012 or in the alternative method described in 6.3), which is solely the heat flow rate through the frame excluding the lateral heat flow effects of panels and interaction with the frame.  $U_{\text{TJ}}$  should not be used to assess condensation risk.

#### 6.2.2.2 Determination of the area-related joint thermal transmittance $U_{\text{TJ}}$

The heat flow rate  $\Phi_{\text{TJ}}$ , which represents the additional heat flow rate due to making a thermal joint between two filling elements, can be calculated as:

$$\Phi_{\text{TJ}} = \Phi_{\text{tot}} - (U_{\text{FE1}} A_{\text{FE1}} + U_{\text{FE2}} A_{\text{FE2}}) \Delta T \quad (1)$$

where

$\Delta T$  is the temperature difference between internal and external environments used to simulate the heat transfer.

The thermal transmittance of the joint  $U_{TJ}$  [see Figure 7a)] is calculated as:

$$U_{TJ} = \Phi_{TJ} / (A_{TJ} \Delta T) \tag{2}$$

where

$A_{TJ}$  is the projected area of the thermal joint;

$\Delta T$  is the temperature difference between the internal and external environment used for the simulation.

NOTE For the example in Figure 7a, the areas and U-values of the filling elements are defined as follows:

$$A_g = A_{FE1}, A_p = A_{FE2}, U_g = U_{FE1}, U_p = U_{FE2}$$

**6.2.2.3 Determination of the linear joint thermal transmittance  $\Psi_{TJ}$**

The definition of the filling element areas is different from the definition in Figure 7a) and is as specified in Figure 7b). The calculation of  $\Phi_{TJ}$  is according to Equation (3).

The heat flow rate  $\Phi_{TJ}$  can be calculated as:

$$\Phi_{TJ} = \Phi_{tot} - (U_{FE1} A_{FE1} + U_{FE2} A_{FE2}) \Delta T \tag{3}$$

where

$\Delta T$  is the temperature difference between inside and outside air used to simulate the heat transfer.

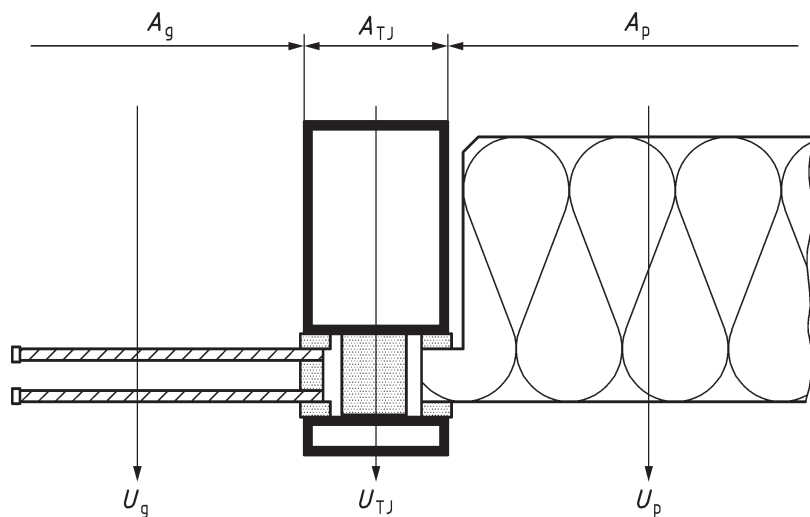

**a) Definition of the areas when using  $U_{TJ}$  (example: glazing, mullion, panel)**

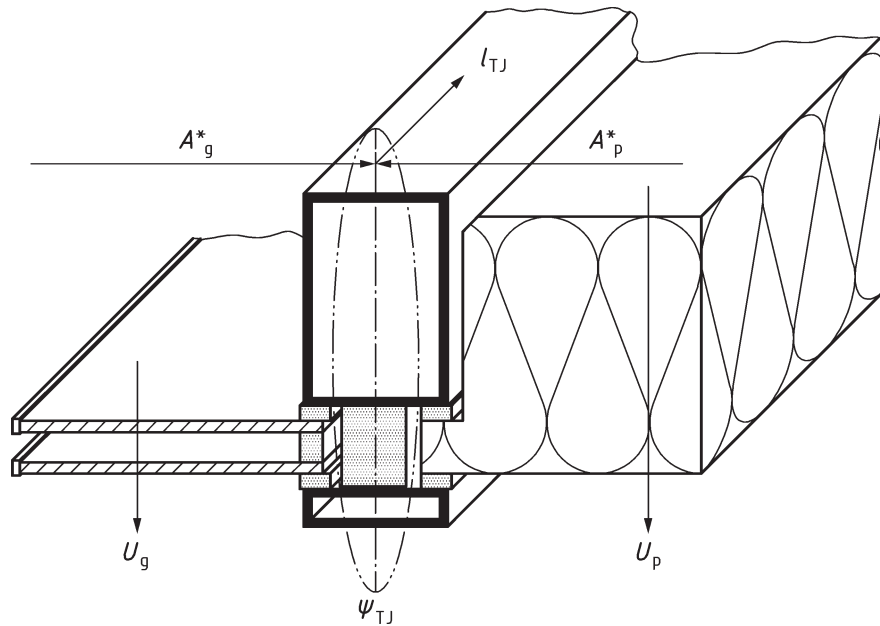

b) Definition of the areas when using  $\psi_{TJ}$  (example: glazing, mullion, panel)

Figure 7 — Definition of the areas

The linear thermal transmittance of the joint  $\psi_{TJ}$  is calculated as:

$$\psi_{TJ} = \Phi_{TJ} / (l_{TJ} \Delta T) \quad (4)$$

where

$\Delta T$  is the temperature difference between the internal and external environments used for the simulation.

#### 6.2.2.4 Definitions of areas for other combinations

Figures 8 to 11 give further examples of how the curtain wall can be decomposed into parts for analysis by the single assessment method. The area of the joint  $A_{TJ}$  is the largest of the projected areas between the two filling elements. The length  $l_{TJ}$  is the length of the thermal joint connecting the filling elements.

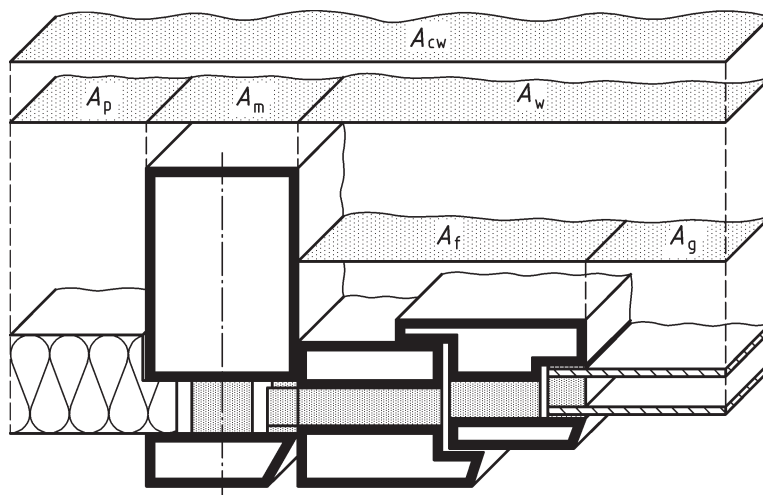

**Key**

- |          |                 |       |              |
|----------|-----------------|-------|--------------|
| $A_m$    | mullion         | $A_w$ | window area  |
| $A_{cw}$ | curtain walling | $A_f$ | frame area   |
| $A_p$    | panel area      | $A_g$ | glazing area |

**Figure 8 — Example 1: Framed curtain wall**

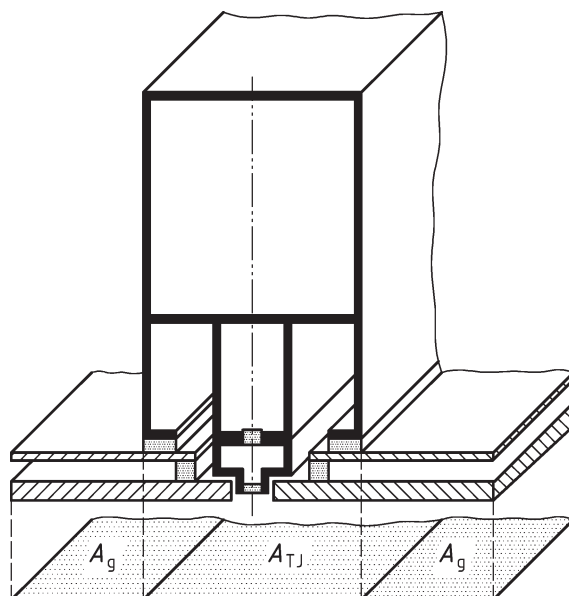

**Key**

- |       |                       |
|-------|-----------------------|
| $A_T$ | area of thermal joint |
| $A_g$ | glazing area          |

**Figure 9 — Example 2: Structural silicone glazing**

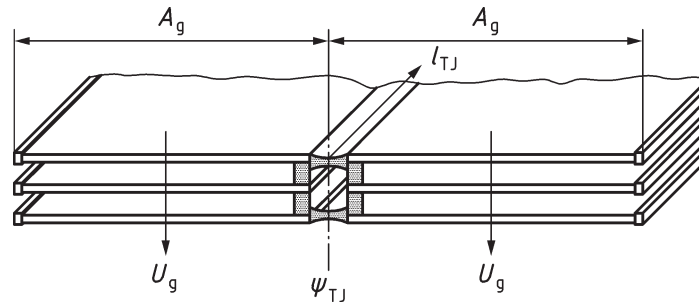
**Key**

TJ thermal joint

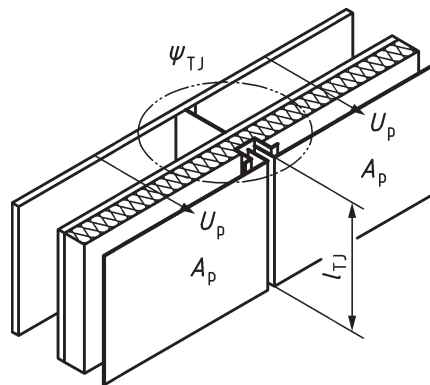
**Figure 10 — Example 3: Structural glazing**

**Figure 11 — Example 4: Rain screen**
**6.2.3 Determination of the overall thermal transmittance of a curtain wall ( $U_{CW}$ )**
**6.2.3.1 Using the area-related thermal transmittance  $U_{TJ}$** 

The overall thermal transmittance of the curtain wall element  $U_{CW}$  is calculated as the area-weighted average of all the thermal transmittances of the joints, glazing units and panels.

$$U_{CW} = \frac{\sum A_g U_g + \sum A_p U_p + \sum A_{TJ} U_{TJ}}{\sum A_g + \sum A_p + \sum A_{TJ}} \quad (5)$$

where the areas  $A_g$  and  $A_p$  are defined according to Figure 7a).

**6.2.3.2 Using the length-related linear thermal transmittance  $\psi_{TJ}$** 

The overall thermal transmittance of the curtain wall element  $U_{CW}$  is calculated as the area-weighted average of all the thermal transmittances of glazing units and panels and the linear thermal transmittances of the joints.

$$U_{CW} = \frac{\sum A_g^* U_g + \sum A_p^* U_p + \sum l_{TJ} \psi_{TJ}}{A_g^* + A_p^*} \quad (6)$$

using the areas  $\sum A_g^*$  and  $\sum A_p^*$  as defined according to Figure 7b).

### 6.3 Component assessment method

#### 6.3.1 General

The thermal transmittance of a single element of a curtain walling,  $U_{CW}$ , shall be calculated using Equation (7).

$$U_{CW} = \frac{\sum A_g U_g + \sum A_p U_p + \sum A_f U_f + \sum A_m U_m + \sum A_t U_t + \sum l_{f,g} \Psi_{f,g} + \sum l_{m,g} \Psi_{m,g} + \sum l_{t,g} \Psi_{t,g} + \sum l_p \Psi_p + \sum l_{m,f} \Psi_{m,f} + \sum l_{t,f} \Psi_{t,f}}{A_{CW}} \quad (7)$$

where

$U_g, U_p$  are the thermal transmittances of glazing and panels;

$U_f, U_m, U_t$  are the thermal transmittances of frames, mullions and transoms;

$\Psi_{f,g}, \Psi_{m,g}, \Psi_{t,g}, \Psi_p$  are the linear thermal transmittances due to the combined thermal effects of glazing unit or panel and frame or mullion or transom;

$\Psi_{m,f}, \Psi_{t,f}$  are the linear thermal transmittances due to the combined thermal effects of frame-mullion and frame-transom

and the other symbols are defined in Clause 3.

The area of the curtain walling shall be calculated according to Equation (8):

$$A_{CW} = A_g + A_p + A_f + A_m + A_t \quad (8)$$

where

$A_{CW}$  is the area of curtain walling;

$A_g$  is the total area of glazing;

$A_p$  is the total area of panels;

$A_f$  is the total area of frames;

$A_m$  is the total area of mullions;

$A_t$  is the total area of transoms.

#### 6.3.2 Definition of areas

##### 6.3.2.1 Glazed areas

The glazed area,  $A_g$ , or the opaque panel area,  $A_p$ , of a component is the smaller of the visible areas that can be seen from both sides (see Figures 12 and 13). Any overlapping of the glazed area by the gaskets is ignored.

##### 6.3.2.2 Total visible perimeter of the glazing or opaque panel

The total perimeter of glazing,  $l_g$ , or of an opaque panel,  $l_p$ , is the sum of the visible perimeter of the glass panes (or opaque panels). If different perimeters are seen from each side, the perimeter is defined by the interface of the area of the glazing and the frame (see Figure 12).

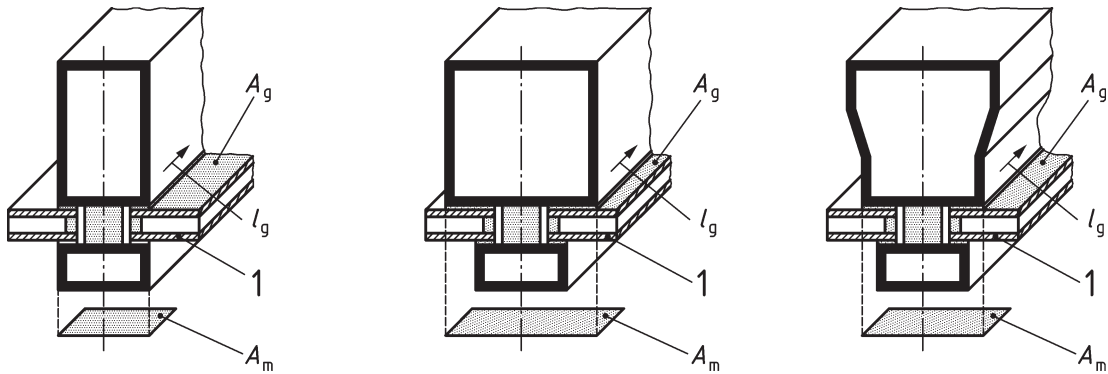
**Key**

1 glass

**Figure 12 — Illustration of the glazed area and perimeter****6.3.2.3 Areas of frames, mullions and transoms**

For the definition of the areas see also Figures 13 and 14.

$A_{m,i} / A_{t,i}$  is the internal projected mullion/transom area at the interface glazing/mullion/transom, equal to the area of the projection of the internal mullion/transom on a plane parallel to the wall;

$A_{m,e} / A_{t,e}$  is the external projected mullion/transom area at the interface glazing/mullion/transom, equal to the area of the projection of the external mullion/transom on a plane parallel to the wall;

$A_m / A_t$  is the mullion/transom area, equal to the larger of the two projected areas seen from either side;

$A_{f,i}$  is the internal projected frame area at the interface glazing/frame, equal to the area of the projection of the internal frame on a plane parallel to the wall;

$A_{f,e}$  is the external projected frame area at the interface glazing/frame, equal to the area of the projection of the external frame on a plane parallel to the wall;

$A_f$  is the frame area, equal to the larger of the two projected areas seen from either side.

$$A_m = \max (A_{m,i}; A_{m,e})$$

$$A_t = \max (A_{t,i}; A_{t,e})$$

$$A_f = \max (A_{f,i}; A_{f,e})$$

$$A_w = A_f + A_g$$

$$A_{cw} = A_t + A_m + A_f + A_g + A_p$$

In Figure 13 only a mullion is shown. The general principal is also applicable for transoms.

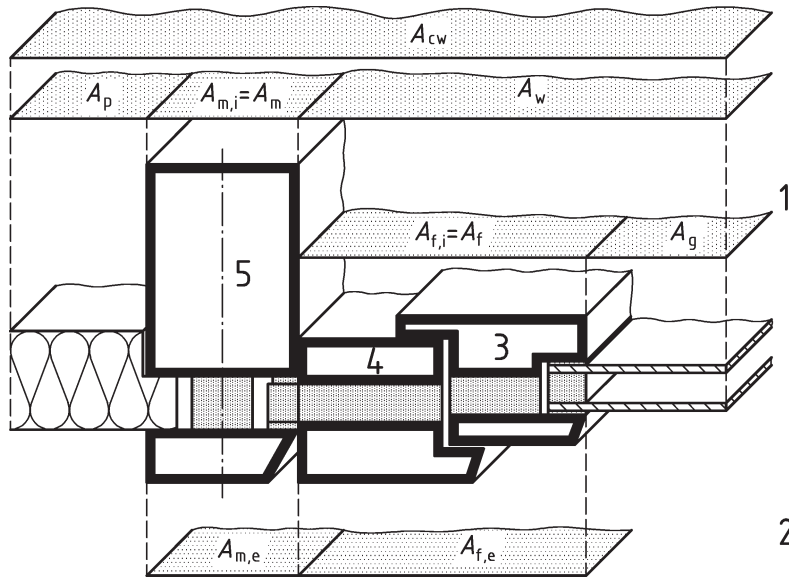

**Key**

- |   |                 |           |                       |           |                       |
|---|-----------------|-----------|-----------------------|-----------|-----------------------|
| 1 | internal        | $A_{CW}$  | curtain walling       | $A_f$     | frame area            |
| 2 | external        | $A_p$     | panel area            | $A_g$     | glazing area          |
| 3 | sash (movable)  | $A_{m,i}$ | internal mullion area | $A_{m,e}$ | external mullion area |
| 4 | frame (fixed)   | $A_m$     | mullion               |           |                       |
| 5 | mullion/transom | $A_{f,e}$ | external frame area   |           |                       |

**Figure 13 — Illustration of the various areas on mullion or transom sections, panels and glazing**

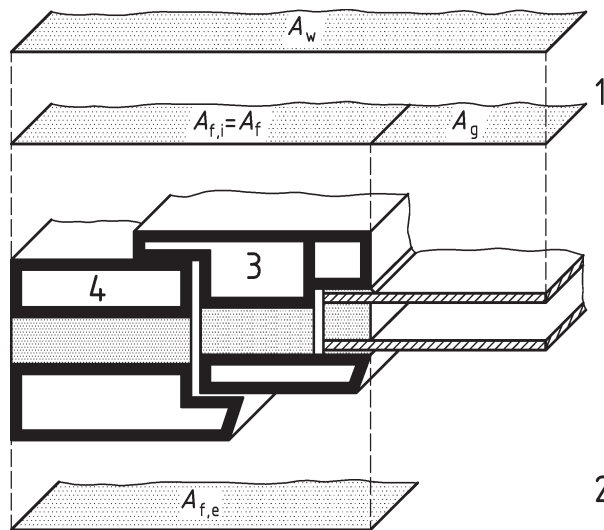

**Key**

- |   |                |
|---|----------------|
| 1 | internal       |
| 2 | external       |
| 3 | sash (movable) |
| 4 | frame (fixed)  |

**Figure 14 — Illustration of the various areas on frame-sash sections and glazing**

**6.3.2.4 Area of a module of curtain walling**

If the internal or external frame has a complex geometrical shape, the frame section  $A_f$  is determined according to Figure 14, and the mullion and transom section  $A_m$  and  $A_t$  are determined according to Figure 13. The total area  $A_{CW}$ , of an element of curtain walling is the sum of the mullion/transom area,  $A_m / A_t$ , the frame area,  $A_f$ , the glazing area,  $A_g$ , and the panel area,  $A_p$  (see also Figure 13).



### 6.3.3 Thermal transmittance of glazing units and panels (filling elements)

The thermal transmittance of opaque panels  $U_p$  shall be evaluated according to ISO 6946:2007. The thermal transmittance of glazing units  $U_g$  shall be evaluated according to the documents listed in Table G.1. In some cases, there is a different filling element at each side of the thermal joint (mullion, transom), so that two thermal transmittances have to be calculated.

### 6.3.4 Thermal transmittance of frames, mullions and transoms

The  $U_f$  values of the sash and frame sections can be evaluated according to EN 12412-2:2003, ISO 10077-1:2006 or ISO 10077-2:2012. See also Annex B concerning the boundary conditions for the calculation of  $U_f$  for frames which are integrated in the façade.

The  $U_t$  and  $U_m$  values for the transom and mullion sections can be evaluated according to EN 12412-2:2003 or ISO 10077-2:2012.

The  $U$ -value calculated according to ISO 10077-2:2012 does not take into account the effect of screws connecting the internal to the external sections of mullions and transoms. The effect of screws shall be included using Equations (9) and (10).

$$U_m = U_0 + \Delta U \quad (9)$$

$$U_t = U_0 + \Delta U \quad (10)$$

where

$U_m / U_t$  is the thermal transmittance of the mullion/transom;

$U_0$  is the thermal transmittance of the mullion/transom calculated according to ISO 10077-2:2012 excluding the effect of metal connectors (screws);

$\Delta U$  is the difference in the thermal transmittance of mullion/transom with and without screws.

Values for  $\Delta U$  are given in Table 2.

**Table 2 — Values of  $\Delta U$  for mullion and transom sections for stainless steel connectors**

Diameter of stainless steel connectors mm	Distance between stainless steel connectors mm	$\Delta U$ W/(m <sup>2</sup> ·K)
≤ 6	200 to 300	0,3

$\Delta U$  depends on the distance between the connectors, the diameter and the materials used.

An alternative to using the values given in Table 2 is to measure  $\Delta U$  using the procedures specified in EN 12412-2:2003. In this case,  $\Delta U$  is derived from the difference between measured values for specimens with metal screws and those on the same specimen but using plastic screws (which are assumed to have a negligible effect).  $\Delta U$  can also be evaluated by a three dimensional calculation according to ISO 10211:2007 obeying the specific rules for cavities given in ISO 10077-2:2012.

A second alternative is to calculate the influence of the screws according to Annex C.

It is common practice to produce "profile systems" comprising a large number of different frames, having a wide range of geometric shapes but having similar thermal properties. This is because in these groups of frames, the important parameters such as the size, material and design of the thermal break, are the same. The thermal transmittance of a profile or profile combination of a "profile system" can be evaluated by:

- using the highest value of  $U_f$  or  $U_m/U_t$  of the profiles or profile combinations within the profile system, or
- using trend lines that show the relationship between  $U_f$  or  $U_m/U_t$  and defined geometrical characteristics.

In the latter case, the data points for the trend line are evaluated on selected profile cross-sections, taken from the profile system in question. Detailed procedures are described in [2], [3] and [4] of the Bibliography.

### 6.3.5 Linear thermal transmittance

Values for the linear thermal transmittance of glazing units,  $\Psi_g$ , are given in Table B.1, B.2, B.3 and B.4 or can be calculated using ISO 10077-2:2012. In the case of single glazing,  $\Psi_g$  in Equation (7) shall be taken as zero (no spacer effect) because any correction is negligible.

Values for the linear thermal transmittance  $\Psi_p$  of panels are given in Table B.5 or can be calculated using ISO 10077-2:2012.

The interaction between the frame and the mullion or transom caused by the installation of the frame into the rebate of the mullion or transom (Figure 15) is accounted for with the linear thermal transmittances  $\Psi_{m,f}$  and  $\Psi_{t,f}$ .

Values for the linear thermal transmittances  $\Psi_{m,f}$  and  $\Psi_{t,f}$  describing the thermal heat flow due to the installation of a window in the façade are given in Table B.6 or Table B.7 or can be calculated using ISO 10077-2:2012:

$$\Psi_{m,f} = L_{\Psi}^{2D} - U_m A_m - U_f A_f - U_{p1} A_{p1} - U_{p2} A_{p2} \quad (11)$$

$$\Psi_{t,f} = L_{\Psi}^{2D} - U_t A_t - U_f A_f - U_{p1} A_{p1} - U_{p2} A_{p2} \quad (12)$$

where

$L_{\Psi}^{2D}$  is the thermal conductance of the section shown in Figure 13, in W/(m·K), calculated using ISO 10077-2:2012;

$U_f$  is the thermal transmittance of the frame, in W/(m<sup>2</sup>·K), calculated using ISO 10077-2:2012;

$U_m$  is the thermal transmittance of the mullion, in W/(m<sup>2</sup>·K), calculated using ISO 10077-2:2012;

$U_t$  is the thermal transmittance of the transom, in W/(m<sup>2</sup>·K), calculated using ISO 10077-2:2012;

$U_{p1}$  is the thermal transmittance of panel 1, in W/(m<sup>2</sup>·K);

$U_{p2}$  is the thermal transmittance of panel 2, in W/(m<sup>2</sup>·K).

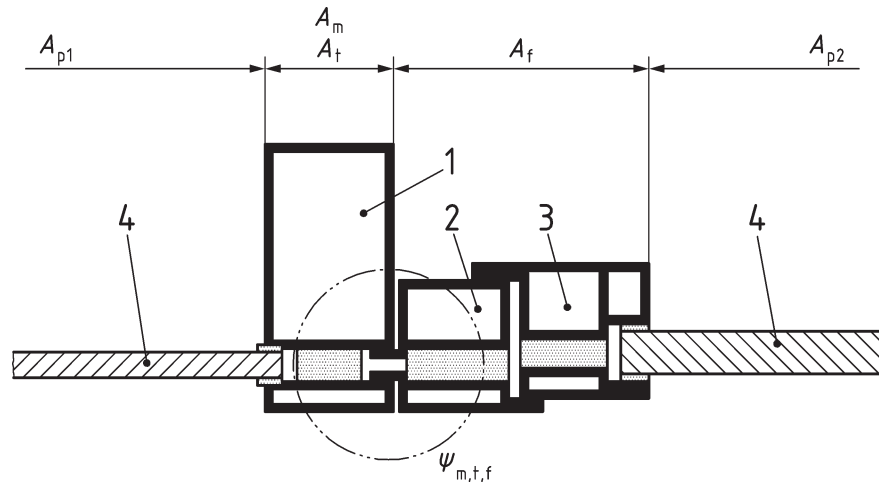

### Key

- 1 transom or mullion
- 2 frame (fixed)
- 3 sash (movable)
- 4 infill, panel

Figure 15 — Illustration of a window integrated in a transom or mullion section

## 6.4 Thermal transmittance of a curtain wall built of different elements

The calculation of  $U_{cw,tot}$  of the overall curtain wall built with different sizes or design of elements shall be calculated as the area-weighted average thermal transmittance of all modules according to Equation (13).

$$U_{cw,tot} = \frac{\sum(U_{cw,j} A_{cw,j})}{\sum A_{cw,j}} \quad (13)$$

where

$\sum U_{cw,j} A_{cw,j}$  is the sum of the products of thermal transmittances and corresponding areas of the different modules;

$\sum A_{cw,j}$  is the sum of the areas of the different modules.

## 7 Input data

The thermal property data required to evaluate the thermal transmittance of curtain walling, using the procedures in this International Standard, shall be obtained from Table 3.

Table 3 — Sources of input data

Values of thermal transmittance	Source
$U_g$	Documents listed in Table G.1
$U_f$	EN 12412-2:2003, ISO 10077-1:2006, ISO 10077-2:2012
$U_m, U_t$	EN 12412-2:2003, ISO 10077-2:2012 (and Annex C)
$\Psi_g$ and $\Psi_p$ and $\Psi_{m,f} / \Psi_{t,f}$	Annex B, ISO 10077-2:2012
$U_p$	ISO 6946:2007

The sources of all data shall be stated unambiguously. Ensure that numerical values used relate exactly to the areas as defined in Clause 4.

If the results are to be used for comparison of the performance of different curtain walling, the sources of the numerical values of each parameter shall be the same for each type of curtain walling included in the comparison.

Results obtained for the purposes of comparison of products (declared values) shall be calculated or measured for horizontal heat flow.

Design values should be determined for the actual position and boundary conditions, by including the effect of the inclination of the curtain wall in the determination of  $U_g$ . However, the  $U_m$ ,  $U_t$ ,  $U_f$  and  $\Psi$  as determined for the curtain wall in the vertical position are used for all inclinations of the curtain wall.

Values for the surface thermal resistance can be obtained from ISO 10077-1:2006, Annex A.

## 8 Report

### 8.1 Section drawings

A technical drawing shall be available (preferably scale 1:1) giving the sections of the curtain walling with sufficient details to permit the verification of the following:

- thickness, position type and number of thermal breaks;
- number and thickness of air chambers (for plastic frame sections);
- presence and position of metal stiffening (for plastic frame sections);
- thickness of frames;
- thickness of the gas-spaces and the identification of the gas;
- type of glass, its thickness, its thermal properties and emissivity of its surfaces;
- thickness and description of any opaque panels in the frame;
- position of the glazing and panel unit spacer bars or of the edge stiffening for opaque panels.

The distance between the connections of external and internal frame sections having thermal bridge effects shall be clearly indicated.

## 8.2 Overview drawing of the whole curtain wall element

A drawing of the front view of the whole curtain wall element (seen from outside the building) with the following information shall be available:

- glazed area  $A_g$  and/or opaque panel area  $A_p$ ;
- frame area  $A_f$ ;
- perimeter length of the glazing  $l_g$  and/or of the opaque panels  $l_p$ .

## 8.3 Values used for calculation

If the values in Annex B are used, this shall be stated and reference made to the identifiers of the tables and annexes used.

If measured or calculated values are used, the measurement or calculation methods shall be indicated precisely and it shall be stated that the values obtained correspond to the definitions of the areas given in this International Standard.

## 8.4 Presentation of results

The thermal transmittance of the curtain walling, calculated according to this International Standard, shall be given to two significant figures.

Reference to this International Standard shall be made.

## Annex A (informative)

### Guidance for calculating the thermal transmittance $U_{CW}$ of curtain walling using the two methods

**Table A.1 — Summary of the procedure for determining  $U_{CW}$  of curtain walling**

Single assessment method	Component assessment method
1. Frames (joints) 1.1 Definition and evaluation of areas according to 4.2 1.2 Evaluation of $U_{TJ}$ or $\Psi_{TJ}$ according to 6.2	1. Frames 1.1 Definition and evaluation of areas according to 4.2 1.2 Evaluation of $U_f$ , $U_m$ and $U_t$ values according to ISO 10077-2:2012 (see 6.3.4) or EN 12412-2:2003 Evaluation of $\Psi_{m,f}$ / $\Psi_{t,f}$ according to Table B.6 of this standard or ISO 10077-2:2012
2. Glazing 2.1 Definition and evaluation of areas according to this International Standard 2.2 Evaluation of $U_g$ according to ISO 10077-1:2006 or documents listed in Table G.1	2. Glazing 2.1 Definition and evaluation of areas according to this International Standard 2.2 Evaluation of $U_g$ according to ISO 10077-1:2006 or documents listed in Table G.1 2.3 Evaluation of $\Psi_{t,g}$ , $\Psi_{m,g}$ and $\Psi_{f,g}$ according to Table B.1, B.2, B.3 or B.4 of this International Standard or ISO 10077-2:2012
3. Panels 3.1 Definition and evaluation of areas according to 4.2 3.2 Evaluation of $U_p$ according to ISO 6946:2007	3. Panels 3.1 Definition and evaluation of areas according to 4.2 3.2 Evaluation of $U_p$ according to ISO 6946:2007 3.3 Evaluation of $\Psi_p$ -values according to Table B.5 or ISO 10077-2:2012
4. Complete elements 4.1 Calculation of complete elements according to Equations (5) and (6)	4. Complete elements 4.1 Calculation of complete elements according to Equation (7)
5. Complete curtain walling 5.1 Calculation of a façade built of different elements according to Equation (13)	5. Complete curtain walling 5.1 Calculation of a façade built of different elements according to Equation (13)

## Annex B (informative)

### Linear thermal transmittance of junctions

The thermal transmittance of glazing units,  $U_g$ , and panels,  $U_p$ , are applicable to the central area of the glazing unit or panel and do not include the effect of the spacers at the edge of the glazing unit or the panel. The thermal transmittance of frame, mullions and transoms ( $U_f$ ,  $U_m$ ,  $U_t$ ), however, has been defined without the presence of the glazing or panel. The linear thermal transmittance  $\Psi$  describes the additional heat conduction due to the interaction between frame, glazing unit or panel and spacer. The linear thermal transmittance,  $\Psi$ , is mainly determined by the thermal conductivity of the spacer material and the design of the frame or mullion/transom.

Values of linear thermal transmittance can be established by numerical calculation according to ISO 10077-2:2012. If detailed results are not available, the values in this Annex may be used.

Tables B.1 and Table B.2 give the  $\Psi_{m,g}$ ,  $\Psi_{t,g}$  values for spacers used in glazing units installed in mullions/transoms.

Tables B.3 and Table B.4 give the  $\Psi_{f,g}$  values for spacers used in glazing units installed in frames.

Table B.5 gives the  $\Psi_p$  values for spacers used in opaque panels.

Tables B.6 and Table B.7 give the  $\Psi_{m,f}$ /  $\Psi_{t,f}$  values for mullion/transom-frame junctions.

**Table B.1 — Values of the linear thermal transmittance  $\Psi_{m,g}$  and  $\Psi_{t,g}$  in  $W/(m \cdot K)$  for normal types of glazing spacer bars (e.g. aluminium and steel – desiccant-filled) used in glazing units installed in transoms/mullions**

Mullion or transom type	Glazing type	
	Double or triple glazing — uncoated glass — air or gas filled  $W/(m \cdot K)$	Double or triple glazing — low emissivity glass * 1 pane coated for double glazed * 2 panes coated for triple glazed - air or gas filled  $W/(m \cdot K)$
Aluminium-wood	0,08	0,11
Metal with a thermal break	$d_i \leq 100$ mm: 0,13 $d_i \leq 200$ mm: 0,15	$d_i \leq 100$ mm: 0,17 $d_i \leq 200$ mm: 0,19
$d_i$ is the internal depth of the mullion or transom (see also Figure 3).		

**Table B.2 — Values of the linear thermal transmittance  $\Psi_{m,g}$  and  $\Psi_{t,g}$  in W/(m·K) for thermally improved types of glazing spacer bars used in glazing units installed in transoms/mullions**

Mullion or transom type	Glazing type	
	Double or triple glazing — uncoated glass — air or gas filled  W/(m·K)	Double or triple glazing — low emissivity glass * 1 pane coated for double glazed * 2 panes coated for triple glazed — air or gas filled  W/(m·K)
Aluminium-wood	0,06	0,08
Metal with a thermal break	$d_i \leq 100$ mm: 0,09 $d_i \leq 200$ mm: 0,10	$d_i \leq 100$ mm: 0,11 $d_i \leq 200$ mm: 0,12
$d_i$ is the internal depth of the mullion or transom (see also Figure 3).		

**Table B.3 — Values of the linear thermal transmittance  $\Psi_{f,g}$  in W/(m·K) for normal types of glazing spacer bars (e.g. aluminium and steel – desiccant-filled) used in glazing units installed in frames**

NOTE 1 This Table is based on ISO 10077-1:2006.

Frame type	Glazing type	
	Double or triple glazing — uncoated glass — air or gas filled  W/(m·K)	Double or triple glazing — low emissivity glass * 1 pane coated for double glazed * 2 panes coated for triple glazed — air or gas filled  W/(m·K)
Wood or PVC	0,06	0,08
Metal with a thermal break	0,08	0,11
Metal without a thermal break	0,02	0,05



**Table B.4 — Values of the linear thermal transmittance  $\Psi_{f,g}$  in W/(m·K) for thermally improved types of glazing spacer bars used in glazing units installed in frames**

NOTE 2 This Table is based on ISO 10077-1:2006.

Frame type	Glazing type	
	Double or triple glazing — uncoated glass — air or gas filled  W/(m·K)	Double or triple glazing — low emissivity glass * 1 pane coated for double glazed * 2 panes coated for triple glazed — air or gas filled  W/(m·K)
Wood or PVC	0,05	0,06
Metal with a thermal break	0,06	0,08
Metal without a thermal break	0,01	0,04

Values for spacers not covered by the tables can be determined by numerical calculation in accordance with ISO 10077-2:2012.

#### Definition of glazing spacer bars with improved thermal performance

For the purpose of this Annex, a thermally improved spacer is defined by the following criteria:

$$\Sigma (d \cdot \lambda) \leq 0,007 \text{ W/K}$$

This criterion is based on the thickness of the materials of the spacer where

$d$  is the thickness of the spacer wall, in m;

$\lambda$  is the thermal conductivity of the spacer material, in W/(m·K).

The product of the spacer wall thickness and the thermal conductivities have to be summed.

The summation applies to all heat flow paths parallel to the principal heat flow direction, the thickness  $d$  being measured perpendicular to the principal heat flow direction (see Figure B.1). Values of thermal conductivity for spacer materials should be taken from ISO 10456 or ISO 10077-2:2012.

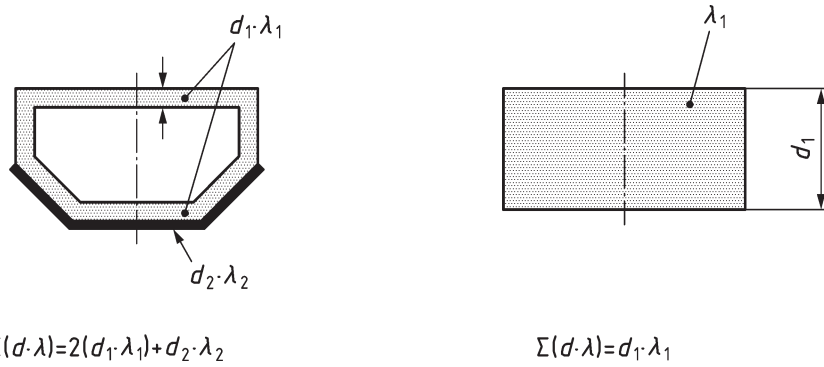
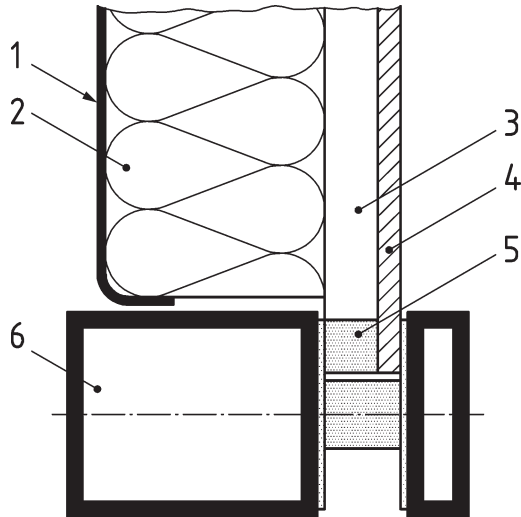

Figure B.1 — Definition of glazing unit spacer bars with improved thermal performance

Table B.5 — Values of the linear thermal transmittance for panel spacers

Filling element type internal/external cladding	Thermal conductivity of spacer $\lambda$ W/(m·K)	Values of the linear thermal transmittance <sup>a</sup> $\psi_p$ W/(m·K)
Panel type 1 (see Figure B.2) with cladding: aluminium/aluminium aluminium/glass or steel/glass	—	0,13
Panel type 2 (see Figure B.3) with cladding: aluminium/aluminium	0,2	0,20
	0,4	0,29
aluminium/glass	0,2	0,18
	0,4	0,20
steel/glass	0,2	0,14
	0,4	0,18

<sup>a</sup> This value may be taken if no information from measurements or detailed calculations is available.



**Key**

- 1 aluminium 2,5 mm / steel 2,0 mm
- 2 insulating material  $\lambda = 0,025 \text{ W/(m-K)}$  to  $0,04 \text{ W/(m-K)}$
- 3 air space 0 to 20 mm
- 4 aluminium 2,5 mm / glass 6 mm
- 5 spacer  $\lambda = 0,2 \text{ W/(m-K)}$  to  $0,4 \text{ W/(m-K)}$
- 6 aluminium

**Figure B.2 — Panel type 1**

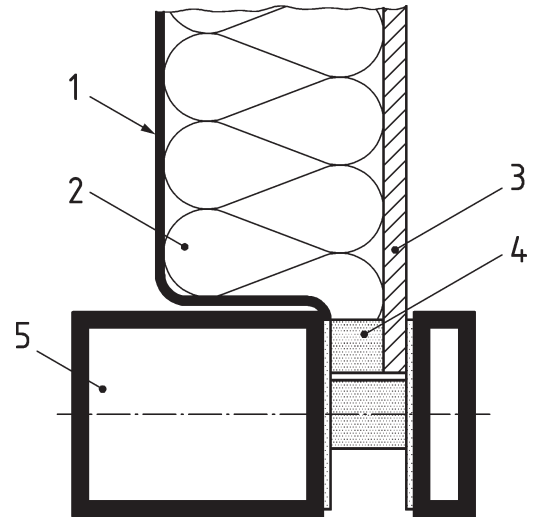

**Key**

- 1 aluminium 2,5 mm / steel 2,0 mm
- 2 insulating material  $\lambda = 0,025 \text{ W/(m-K)}$  to  $0,04 \text{ W/(m-K)}$
- 3 aluminium 2,5 mm / glass 6 mm
- 4 spacer  $\lambda = 0,2 \text{ W/(m-K)}$  to  $0,4 \text{ W/(m-K)}$
- 5 aluminium

**Figure B.3 — Panel type 2**

Table B.6 — Values of the linear thermal transmittance for mullion/transom-frame junctions – aluminium and steel profiles

Junction type	Figure	Description	Values of the linear thermal transmittance <sup>aa</sup> $\Psi_{m,f}$ or $\Psi_{t,f}$ W/(m·K)
A	 <p><b>Key</b> 1 metal 2 thermal break</p>	Mounting of the frame to the mullion with an additional aluminium profile with thermal break	0,11
B		Mounting of the frame to the mullion with an additional profile with low thermal conductivity, e.g. polyamide 6.6 with 25 % glass fibre	0,05
C1	 <p><b>Key</b> 1 thermal break</p>	Mounting of the frame to the mullion using the extension of the thermal break of the frame	0,07
C2		Mounting of the frame to the mullion using the extension of thermal break (e.g. polyamide 6.6 with 25 % glass fibre) of the frame	0,07

Table B.6 (continued)

Junction type	Figure	Description	Values of the linear thermal transmittance <sup>aa</sup> $\Psi_{m,f}$ or $\Psi_{t,f}$ W/(m·K)
D	 <p>Key 1 metal extension</p>	Mounting of the frame to the mullion with an extension of the outer aluminium profile. Infill material for the fixing of low thermal conductivity ( $\lambda \leq 0,3$ W/(m·K))	0,07
<p><sup>a</sup> This value may be taken if no measured or detailed calculation values are available. These values are only valid if the mullion/transom and also the frame have thermal breaks and one thermal break is not short circuited by a non-thermally broken part of the other frame.</p>			

$\Psi$ -values not covered by the tables can be determined by a numerical calculation method specified in ISO 10077-2:2012.

Table B.7 — Values of the linear thermal transmittance for mullion/transom-frame junctions — Wood and aluminium wood profiles

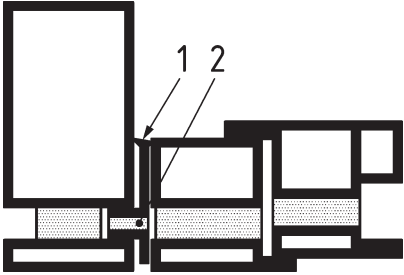
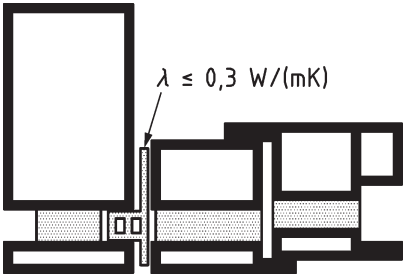
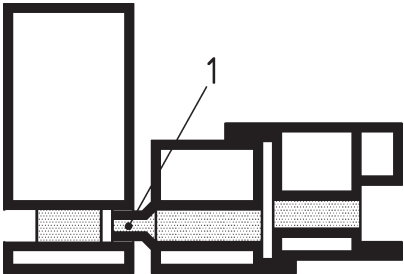
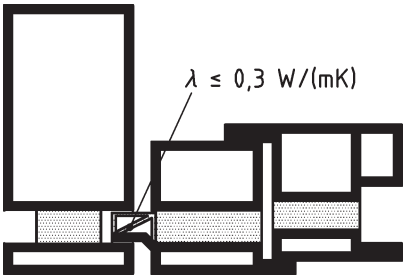
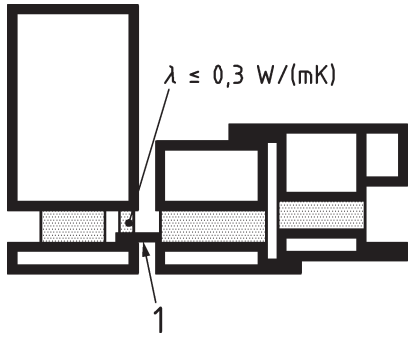
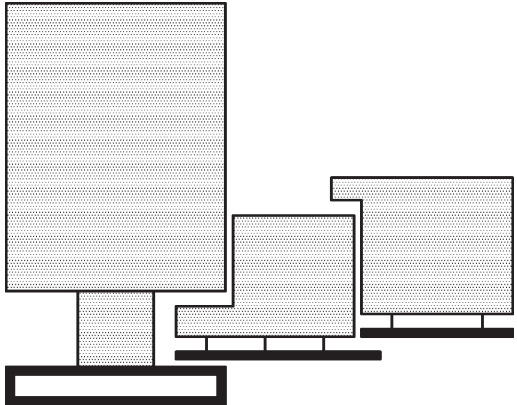
Junction type	Figure	Values of the linear thermal transmittance <sup>a</sup> $\Psi_{m,f}$ or $\Psi_{t,f}$ W/(m·K)
<p>A</p> <p><math>U_m &gt; 2,0</math> W/(m<sup>2</sup>·K)</p>		0,02
<p>B</p> <p><math>U_m \leq 2,0</math> W/(m<sup>2</sup>·K)</p>		0,04
<p><sup>a</sup> This value may be taken if no measured or detailed calculation values are available.</p>		

**Calculation of  $U_f$  for frame profiles installed in the façade**

$U_f$  for frames which are installed with an additional profile in the façade (mullion/frame junction type A and type B) are calculated according to ISO 10077-2:2012. The additional profile is not considered in the calculation of  $U_f$ . The heat flow in the additional profile is a component of the linear thermal transmittance  $\Psi_{m,f}$  or  $\Psi_{t,f}$  describing the thermal interaction between the mullion/transom and the window.

The general procedure for the calculation of  $U_f$  value for frames, which are installed directly in the façade (mullion/frame junction type C and type D) is defined in ISO 10077-2:2012. The area of the frame which is installed in the mullion, is seen as adiabatic for the calculation (see Figure B.4). The additional heat flow, due to the inclusion of the window in the façade, is part of the linear thermal transmittance  $\Psi_{m,f}$  or  $\Psi_{t,f}$  describing the thermal interaction between the mullion/transom and the window.

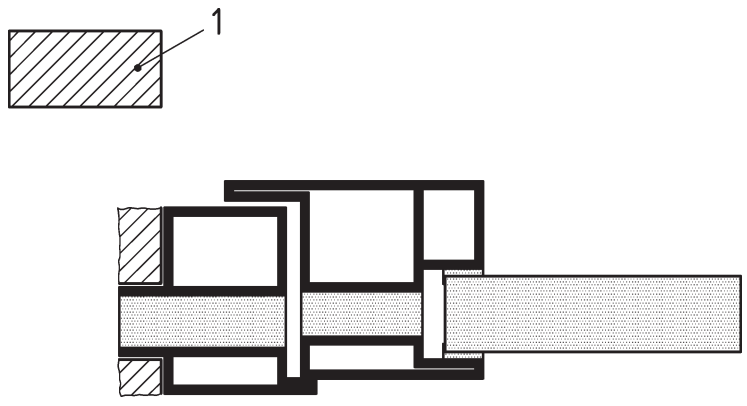

**Key**  
 1 adiabatic

**Figure B.4 — Boundary conditions for the calculation of  $U_f$  for a frame profile, which is directly installed in the façade (mullion/frame junction type C and type D)**

## Annex C (normative)

### A method for calculating the thermal effect of screws using a 2D numerical method and the procedures specified in ISO 10077-2:2012

#### C.1 General

The scope of ISO 10077-2:2012 excludes the thermal effects caused by three dimensional heat transfer such as pin point metallic connections, e.g. screws. But measurements on curtain wall systems have shown the thermal effect of screws cannot be neglected.

This Annex gives a method for evaluating the three dimensional heat transfer caused by screws using a two-dimensional calculation and the procedures specified in ISO 10077-2:2012.

The screw is modelled as a "smoothed" screw with its thickness equal to the real diameter  $d_s$  but an equivalent thermal conductivity  $\lambda_{s,eq}$  (see Figure C.1). The equivalent thermal conductivity is calculated according to Equation (C.1). The equivalent thermal conductivity of the airspace surrounding the screw shall be calculated on the basis that it is a single air space (without screw).

NOTE If the equivalent thermal conductivity of the airspace is calculated automatically by computer software, the software might treat it as two separate airspaces (above and below the smoothed screw as illustrated in the lower right diagram of Figure C.1). That will lead to erroneous results.

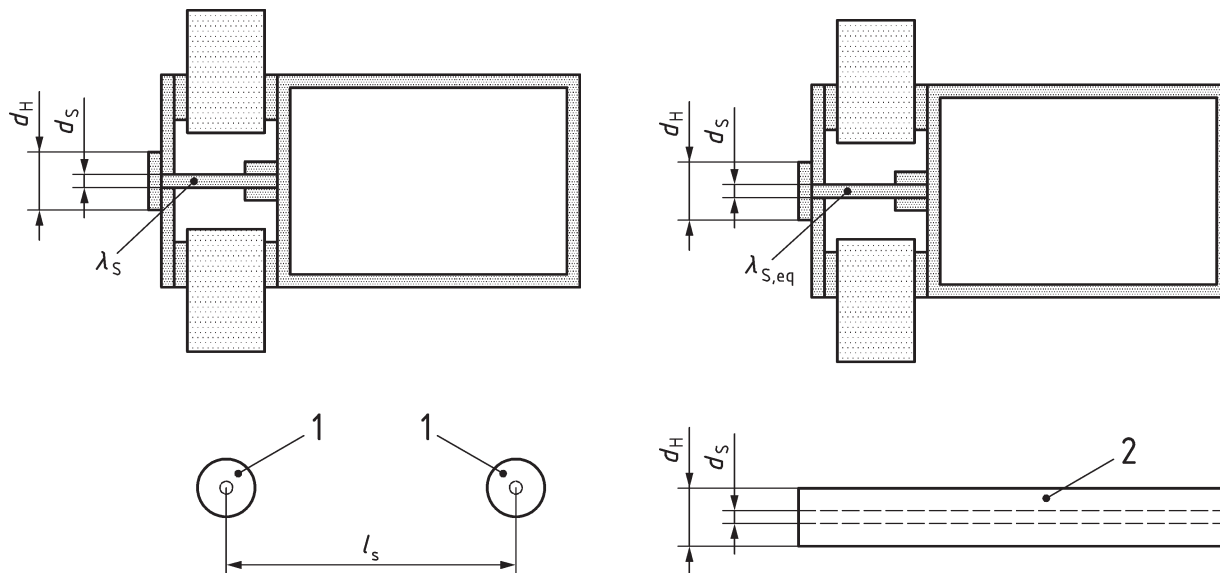

#### Key

- 1 real screws
- 2 smoothed screw

Figure C.1 — Evaluation of the thermal effect of screws using two dimensional numerical calculation

**C.2 Calculation of the equivalent thermal conductivity of the screw  $\lambda_{s,eq}$**

The connection between the pressure plate and the curtain wall profile is done by a screw with diameter  $d_s$ . The thermal conductivity of the screw is  $\lambda_s$ . The distance between the screws is  $l_s$ .

The equivalent thermal conductivity  $\lambda_{s,eq}$  of a smoothed screw with a diameter  $d_s$  is calculated from:

$$\lambda_{s,eq} = \frac{\pi \cdot d_s}{4 \cdot l_s} \cdot (\lambda_s - \lambda_{r,eq}) + \lambda_{r,eq} \tag{C.1}$$

$\lambda_{r,eq}$  is the equivalent thermal conductivity of the materials replaced by the screw and calculated as follows:

$$\lambda_{r,eq} = \frac{\sum_i d_i}{\sum_i \frac{d_i}{\lambda_i}} \tag{C.2}$$

where the summations are over each material through which the screw passes.

Example:

The following example shows the principle of the calculation of the equivalent thermal conductivity of a smoothed screw  $\lambda_{s,eq}$ . The screws used are made of stainless steel ( $\lambda = 15 \text{ W/(m}\cdot\text{K)}$ ) with a diameter  $d_s = 5,5 \text{ mm}$ . The distance between the screws is  $l_s = 200 \text{ mm}$ .

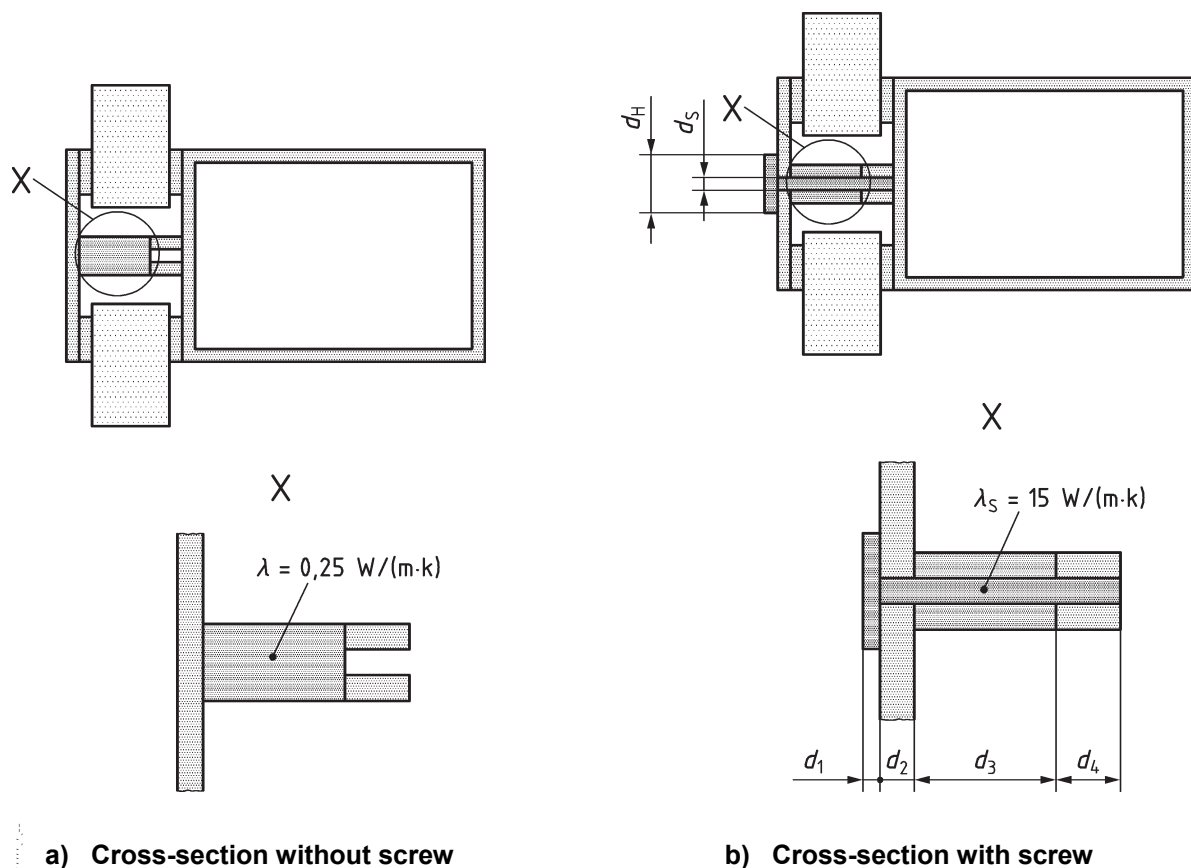

**Figure C.2 — Example for the calculation of the equivalent thermal conductivity of a screw**



- $d_1$  2 mm, screw replaces air cavity with  $\lambda_1 = 0,050 \text{ W/(m}\cdot\text{K)}$   
 $d_2$  4 mm, screw replaces aluminium with  $\lambda_2 = 160 \text{ W/(m}\cdot\text{K)}$   
 $d_3$  25 mm, screw replaces Polyamide with  $\lambda_2 = 0,25 \text{ W/(m}\cdot\text{K)}$   
 $d_4$  15 mm, screw replaces air cavity with  $\lambda_2 = 0,030 \text{ W/(m}\cdot\text{K)}$

$$\lambda_{r,eq} = \frac{\sum_i d_i}{\sum_i \frac{d_i}{\lambda_i}} = \frac{2 \text{ mm} + 4 \text{ mm} + 25 \text{ mm} + 15 \text{ mm}}{\frac{2 \text{ mm}}{0,050 \frac{\text{W}}{\text{m}\cdot\text{K}}} + \frac{4 \text{ mm}}{160 \frac{\text{W}}{\text{m}\cdot\text{K}}} + \frac{25 \text{ mm}}{0,25 \frac{\text{W}}{\text{m}\cdot\text{K}}} + \frac{15 \text{ mm}}{0,030 \frac{\text{W}}{\text{m}\cdot\text{K}}}} = \frac{0,046 \text{ m}}{0,64 \frac{\text{m}^2 \cdot \text{K}}{\text{W}}} = 0,072 \frac{\text{W}}{\text{m}\cdot\text{K}}$$

$$\lambda_{s,eq} = \frac{\pi \cdot d_s}{4 \cdot l_s} \cdot (\lambda_s - \lambda_{r,eq}) + \lambda_{r,eq} = \frac{\pi \cdot 5,5 \text{ mm}}{4 \cdot 0,2 \text{ m}} \cdot (15 \frac{\text{W}}{\text{m}\cdot\text{K}} - 0,072 \frac{\text{W}}{\text{m}\cdot\text{K}}) + 0,072 \frac{\text{W}}{\text{m}\cdot\text{K}} = 0,394 \frac{\text{W}}{\text{m}\cdot\text{K}}$$

### C.3 Consideration of screw heads and washers

Screw heads shall be considered in the 2-dimensional calculation using their actual diameters and the equivalent thermal conductivity of the screw  $\lambda_{s,eq}$ .

Washers shall be considered in the 2-dimensional calculation with their actual diameters and their actual thermal conductivity.

## Annex D (normative)

### Ventilated and unventilated air spaces

Air spaces (ventilated and unventilated) in a curtain wall, e.g. double skin façade, can be taken into account using the data for air layers given in ISO 6946:2007:

- an unventilated air layer is assigned to an effective thermal resistance (ISO 6946:2007, 5.3.2);
- for a ventilated air layer the thermal resistance of the air layer and all other layers between the air layer and external environment are disregarded and the external surface resistance is that corresponding to still air (ISO 6946:2007, 5.3.4 and Annex A);
- a slightly ventilated air layer is intermediate according to the size and distribution of ventilation openings (ISO 6946:2007, 5.3.3).

EXAMPLE Calculation of  $U_{cw}$  for a double skin façade.

The following example shows how  $U_{cw}$  is calculated taking into account the thermal resistance of a slightly ventilated layer (see Figure D.1).

The  $U$ -value of the inner façade (primary façade) is:  $U_{cw,1} = 1,8 \text{ W}/(\text{m}^2 \cdot \text{K})$ .

The  $U$ -value of the outer façade (secondary façade) is:  $U_{cw,2} = 6,0 \text{ W}/(\text{m}^2 \cdot \text{K})$ .

The cavity is slightly ventilated with ventilation openings of  $1200 \text{ mm}^2$  per metre length and the thickness of the air layer is  $300 \text{ mm}$ .

Dimensions in millimetres

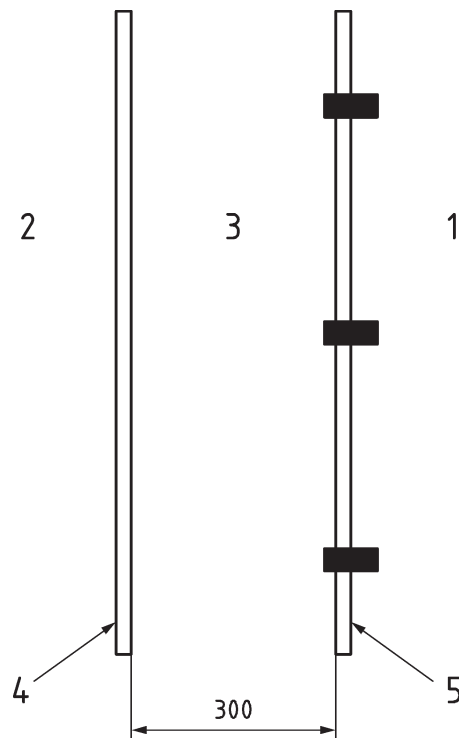
**Key**

- 1 internal
- 2 external
- 3 slightly ventilated layer
- 4 secondary façade  $U_{cw,2} = 6,0 \text{ W/(m}^2\cdot\text{K)}$
- 5 primary façade  $U_{cw,1} = 1,8 \text{ W/(m}^2\cdot\text{K)}$

**Figure D.1 — Example: Calculation of  $U_{cw}$  for a double skin façade**

The total thermal resistance of the overall façade is calculated for the unventilated and ventilated cases.

Unventilated:

$$\begin{aligned}
 R_{cw,u} &= \frac{1}{U_{cw,1}} - R_{si} + R_s - R_{se} + \frac{1}{U_{cw,2}} & (D.1) \\
 &= \frac{1}{1,8} - 0,13 + 0,18 - 0,04 + \frac{1}{6,0} \\
 &= 0,732 \text{ m}^2\cdot\text{K/W}
 \end{aligned}$$

Ventilated:

$$\begin{aligned}
 R_{cw,v} &= \frac{1}{U_{cw,1}} + R_{si} - R_{se} & (D.2) \\
 &= \frac{1}{1,8} + 0,13 - 0,04 \\
 &= 0,646 \text{ m}^2\cdot\text{K/W}
 \end{aligned}$$

The thermal resistance of the curtain wall with a slightly ventilated air layer is

$$R_{cw} = \frac{1500 - A_v}{1000} R_{cw,u} + \frac{A_v - 500}{1000} R_{cw,v} \quad (D.3)$$

where  $A_v$  is the area of external ventilation openings in square millimetres per metre length of wall. Thus:

$$\begin{aligned} R_{cw} &= \frac{1500 - 1200}{1000} \times 0,732 + \frac{1200 - 500}{1000} \times 0,645 \\ &= 0,672 \text{ m}^2 \cdot \text{K/W} \end{aligned}$$

and

$$U_{cw} = \frac{1}{R_{cw}} = 1,5 \text{ W}/(\text{m}^2 \cdot \text{K})$$

.....

## Annex E (informative)

### Component method: Calculation example

#### E.1 Data for examples

This Annex gives an example for the calculation of a curtain walling element according to the component method described in 6.3.

Dimensions in millimetres

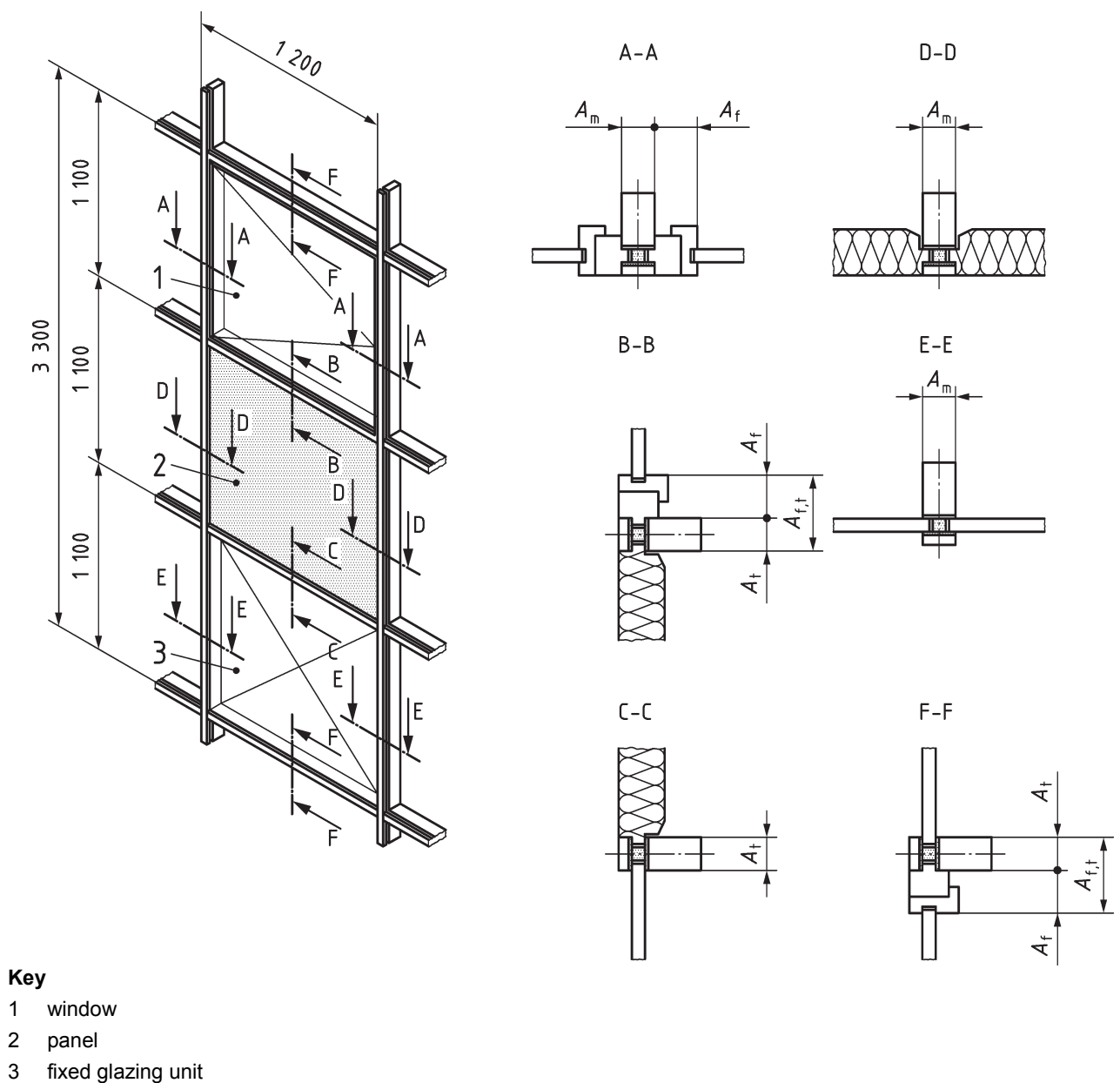

**Figure E.1 — Element of a curtain wall seen from the exterior**

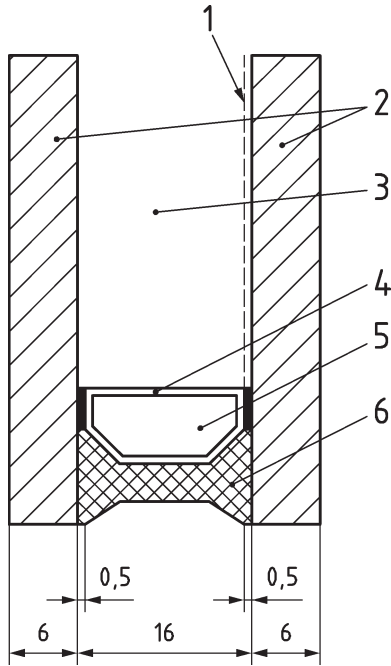

**Key**

- 1 low E coating  $\varepsilon_n = 0,05$
- 2 glass with  $\lambda = 1,0 \text{ W/(m}\cdot\text{K)}$
- 3 argon 90 %
- 4 aluminium with a thickness of 0,5 mm and  $\lambda = 160 \text{ W/(m}\cdot\text{K)}$
- 5 molecular sieve with  $\lambda = 0,13 \text{ W/(m}\cdot\text{K)}$
- 6 polysulfide with  $\lambda = 0,40 \text{ W/(m}\cdot\text{K)}$

**Figure E.2 — Detail of glazing unit**

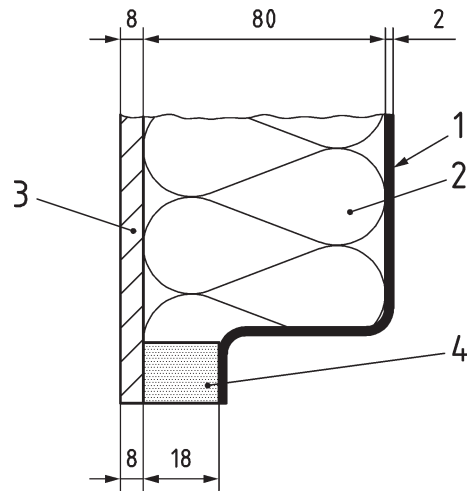

**Key**

- 1 steel
- 2 insulation with  $\lambda = 0,04 \text{ W/(m}\cdot\text{K)}$
- 3 glass with  $\lambda = 1,0 \text{ W/(m}\cdot\text{K)}$
- 4 spacer with  $\lambda = 0,4 \text{ W/(m}\cdot\text{K)}$

**Figure E.3 — Detail of panel**

For the module illustrated in Figures E.1 to E.3, the calculation procedure is in accordance with E.2 to E.4.

E.2 Frames

E.2.1 Definition and evaluation of areas

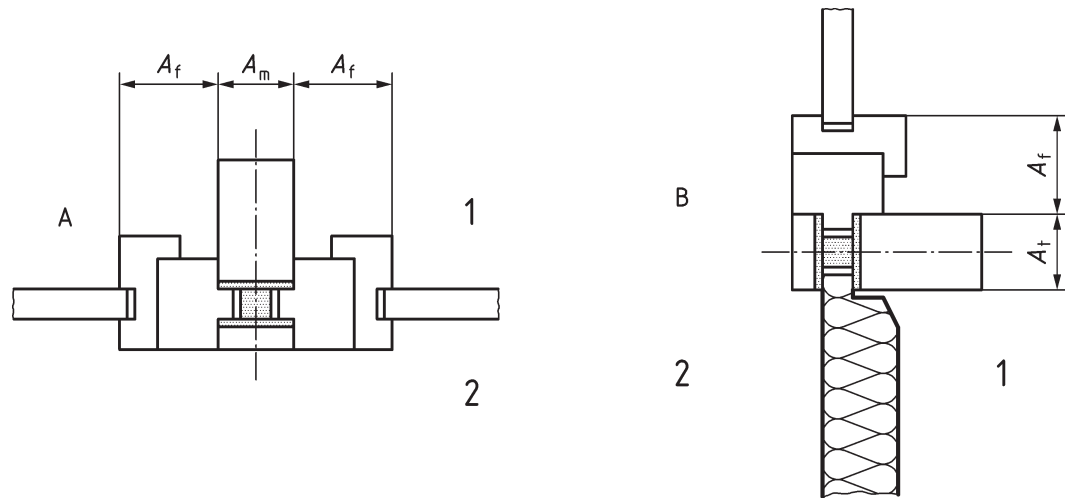

Key

- A mullion – frame
- B transom – frame
- 1 internal
- 2 external

Figure E.4 — Definition of areas

Mullion	$2 \times 3,3 \text{ m} \times 0,025 \text{ m}$	$= 0,165 0 \text{ m}^2$
Area	$A_m$	$= 0,165 0 \text{ m}^2$
Transom	$2 \times (1,20 \text{ m} - 2 \times 0,025 \text{ m}) \times 0,025 \text{ m}$	$= 0,057 5 \text{ m}^2$
	$2 \times (1,20 \text{ m} - 2 \times 0,025 \text{ m}) \times 0,050 \text{ m}$	$= 0,115 0 \text{ m}^2$
Area	$A_t$	$= 0,172 5 \text{ m}^2$
Frame	$2 \times (1,20 \text{ m} - 2 \times 0,025 \text{ m}) \times 0,080 \text{ m}$	$= 0,184 0 \text{ m}^2$
	$2 \times (1,10 \text{ m} - 2 \times 0,025 \text{ m} - 2 \times 0,08 \text{ m}) \times 0,08 \text{ m}$	$= 0,142 4 \text{ m}^2$
Area	$A_f$	$= 0,326 4 \text{ m}^2$
$A_m$	50 mm width	
$A_t$	50 mm width	
$A_f$	80 mm width	

**E.2.2 Evaluation of  $U_f$  values**

$U_f$  values can be taken from measurement according to EN 12412-2:2003 or can be calculated according to ISO 10077-2:2012 (the effect of the screws has to be considered according to 6.3.4). For further calculations in this example it is assumed:

mullion	$U_m$	2,2 W/(m <sup>2</sup> ·K) <sup>a</sup>
transom	$U_t$	1,9 W/(m <sup>2</sup> ·K) <sup>a</sup>
frame	$U_f$	2,4 W/(m <sup>2</sup> ·K)

<sup>a</sup> Measured value according to EN 12412-2:2003.

**E.3 Glazing units**

**E.3.1 Definition and evaluation of areas**

Movable part	width	1,20 m – 2 × 0,025 m – 2 × 0,08 m	= 0,99 m
	height	1,10 m – 2 × 0,025 m – 2 × 0,08 m	= 0,89 m
	$A_g$	0,99 m × 0,89 m	= 0,881 1 m <sup>2</sup>
Fixed part	width	1,20 m – 2 × 0,025 m	= 1,15 m
	height	1,10 m – 2 × 0,025 m	= 1,05 m
	$A_g$	1,15 m × 1,05 m	= 1,207 5 m <sup>2</sup>

**E.3.2 Evaluation of  $U_g$  values**

For further calculations, it is assumed:

$$U_g = 1,2 \text{ W/(m}^2\cdot\text{K)}$$

**E.3.3 Definition of  $l_g$  and evaluation of  $\Psi_g$ ,  $\Psi_{m,f}$  and  $\Psi_{t,f}$**

perimeter			
movable part	$l_{f,g}$	2 × 0,99 m + 2 × 0,89 m	= 3,76 m
fixed part	$l_{t,g} + l_{m,g}$	2 × 1,15 m + 2 × 1,05 m	= 4,40 m

$\Psi$ -values can be taken from Annex A of this International Standard or can be calculated according to ISO 10077-2:2012 (see Tables B.1, B.3 and B.5 of this International Standard)



$\Psi_{f,g}$	movable part	0,11 W/(m·K)
$\Psi_{m,g}$ $\Psi_{t,g}$	fixed part	0,17 W/(m·K)
$\Psi_{m,f}$	Type D2	0,07 W/(m K)
$\Psi_{t,f}$	Type D2	0,07 W/(m K)

## E.4 Panels

### E.4.1 Definition and evaluation of areas

width	$1,20 \text{ m} - 2 \times 0,025 \text{ m}$	= 1,15 m
height	$1,10 \text{ m} - 2 \times 0,025 \text{ m}$	= 1,05 m
area, $A_p$	$1,15 \text{ m} \times 1,05 \text{ m}$	= 1,207 5 m <sup>2</sup>

### E.4.2 Evaluation of $U_p$ values

The  $U$ -value of a panel can be evaluated according to ISO 6946:2007. The panel shown in Figure E.2 gives

$$U_p = 0,46 \text{ W}/(\text{m}^2 \cdot \text{K})$$

### E.4.3 Definition of $l_p$ and evaluation of the $\Psi_p$ values

perimeter	$l_p$	$2 \times 1,15 \text{ m} + 2 \times 1,05 \text{ m}$	= 4,40 m
-----------	-------	---	----------

$\Psi_p$  values can be taken from Annex B, Table B.5 or can be calculated according to ISO 10077-2:2012. A panel shown in Figure E.3 gives

$$\Psi_p = 0,18 \text{ W}/(\text{m} \cdot \text{K})$$

E.4.4 Calculation of a complete element

Table E.1 — Presentation of values of calculation example

	<i>A</i> m <sup>2</sup>	<i>U</i> W/(m <sup>2</sup> ·K)	<i>l</i> m	<i>Ψ</i> W/(m·K)	<i>A·U</i> W/K	<i>Ψ·l</i> W/K
mullion	<i>A<sub>m</sub></i> 0,165 0	<i>U<sub>m</sub></i> 2,2			0,363	
transom	<i>A<sub>t</sub></i> 0,172 5	<i>U<sub>t</sub></i> 1,9			0,328	
frame	<i>A<sub>f</sub></i> 0,326 4	<i>U<sub>f</sub></i> 2,4			0,783	
mullion - frame			<i>l<sub>m,f</sub></i> 2,1	<i>Ψ<sub>m,f</sub></i> 0,07		0,154
transom - frame			<i>l<sub>t,f</sub></i> 2,3	<i>Ψ<sub>t,f</sub></i> 0,07		0,154
glazing						
– movable part	<i>A<sub>g</sub></i> 0,881 1	<i>U<sub>g</sub></i> 1,2	<i>l<sub>f,g</sub></i> 3,76	<i>Ψ<sub>g</sub></i> 0,11	1,057	0,414
– fixed part	<i>A<sub>g</sub></i> 1,207 5	<i>U<sub>g</sub></i> 1,2	<i>l<sub>m,g</sub></i> 4,40 <i>l<sub>t,g</sub></i>	<i>Ψ<sub>g</sub></i> 0,17	1,449	0,748
panel	<i>A<sub>p</sub></i> 1,207 5	<i>U<sub>p</sub></i> 0,46	<i>l<sub>p</sub></i> 4,40	<i>Ψ<sub>p</sub></i> 0,18	0,556	0,792
total	<i>A<sub>CW</sub></i> 3,96				4,536	2,262
$A_{cw} \cdot U_{cw} = \sum A \cdot U + \sum \Psi \cdot l =$					6,80	
$U_{cw} = \frac{\sum A \cdot U + \sum \Psi \cdot l}{A_{cw}} = 6,80/3,96 =$					1,7 (1,72)	

www.iso.org

## Annex F (informative)

### Single assessment method: Calculation example

#### F.1 General description of examples

This Annex gives an example for the calculation of a curtain walling module according to the single assessment method in 6.2. For this example a structural silicone glazing is used.

The calculations are based on the given panel dimensions.

Dimensions in millimetres

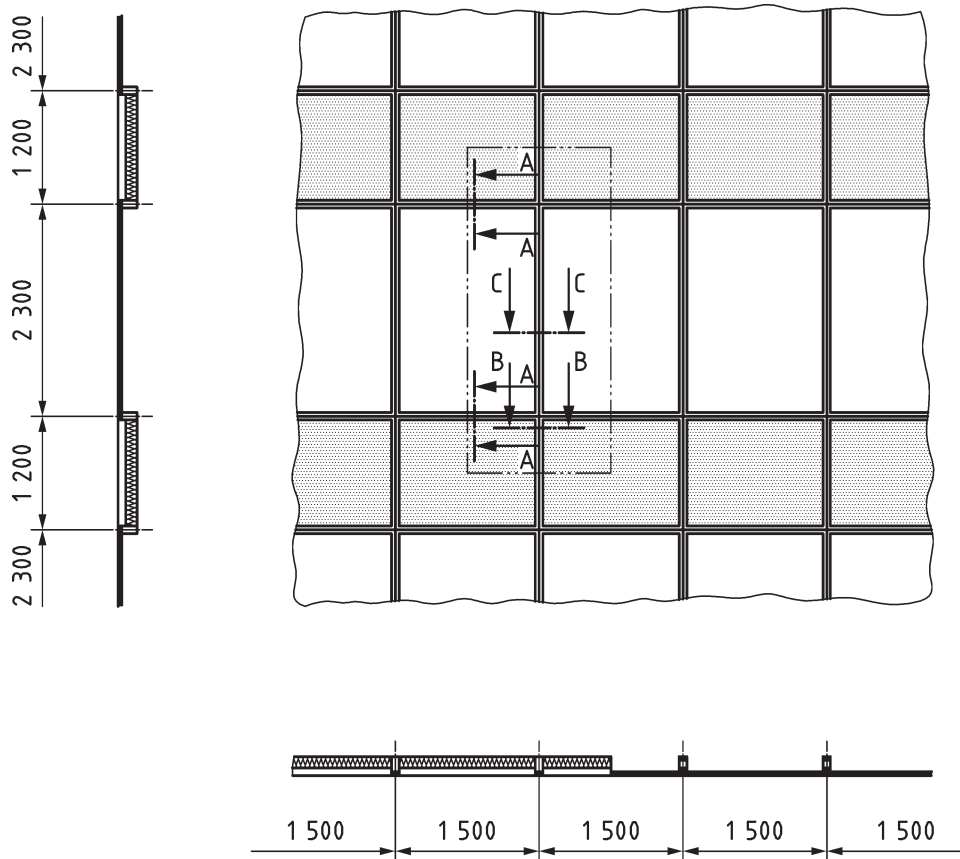

**Key**

- A-A sill/ceiling transom joint
- B-B mullion panel joint
- C-C mullion glass joint

**Figure F.1 — Façade module geometry**

Table F.1 — Panel dimensions

Panel	Dimensions
	mm
Façade module height	3 500
Façade module width	1 500
Spandrel panel height	1 200

## F.2 Centre $U$ -value of the glazing unit

The glazing unit chosen for this calculation is the following:

Outer-light: 8 mm Low E glass ( $\varepsilon_n = 0,04$ );

Cavity: 16 mm air filled;

Inner-light: 5 mm clear glass.

One-dimensional centre  $U$ -value calculation has been performed for this glazing unit in accordance with EN 673: 2011. The one-dimensional thermal transmittance of this glazing unit is found to be:

$$U_g = 1,4 \text{ W/(m}^2\cdot\text{K)}$$

## F.3 Centre $U$ -value of the spandrel panel

The one-dimensional panel thermal transmittance is  $U_p = 0,38 \text{ W/(m}^2\cdot\text{K)}$ , in accordance with ISO 6946:2007.

## F.4 $U$ -values of thermal joints

The thermal joints have been modelled by means of 2-dimensional FEA analysis. Material properties have been taken from ISO 10077-2:2012, Annex A.

The glazing unit has been modelled with aluminium spacers.

The assessed joint  $U$ -value  $U_{TJ}$  represents the heat flow rate through the frame plus all thermal effects due to the thermal interaction between the glass, frame and panel. The projected width of the joint (perpendicular to the filling element direction) excluding the glazing gaskets is measured between the two filling elements. For each of the models, the area of the joints is stated along with the joint  $U$ -value.

Table F.2 — *U*-values of thermal joints

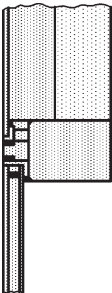
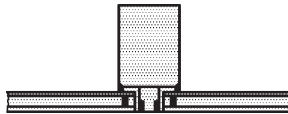
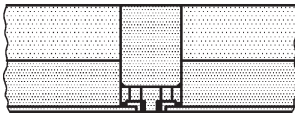
Component	Ceiling transom joint (equal to sill transom joint in this example)	Mullion panel joint	Mullion glass joint
			
$U_{TJ}$ [W/m <sup>2</sup> ·K]	$U_{TJ} = 9,97$ W/(m <sup>2</sup> ·K)	$U_{TJ} = 9,66$ W/(m <sup>2</sup> ·K)	$U_{TJ} = 9,71$ W/(m <sup>2</sup> ·K)
$A_{TJ}$	$A_{TJ} = 0,13$ m <sup>2</sup>	$A_{TJ} = 0,11$ m <sup>2</sup>	$A_{TJ} = 0,21$ m <sup>2</sup>

### F.5 Overall *U*-value of the curtain wall

Area weighting of the *U*-values of all frames, glass and panels is used to calculate the overall *U*-value.

$$U_{cw} = \frac{\sum A_g U_g + \sum A_p U_p + \sum A_{TJ} U_{TJ}}{\sum A_g + \sum A_p + \sum A_{TJ}} \tag{F.1}$$

Table F.3 — Overall *U*-value of the curtain wall

Components	<i>U</i> -value W/(m <sup>2</sup> ·K)	<i>A</i> m <sup>2</sup>	<i>U·A</i> W/K
Ceiling transom joint	9,97	0,13	1,29
Sill transom joint	9,97	0,13	1,29
Mullion glass joint	9,71	0,21	2,05
Mullion panel joint	9,66	0,11	1,07
Spandrel panel centre	0,37	1,56	0,58
Glazing centre	1,40	3,11	4,35
	TOTAL	5,25	10,63
Overall <i>U</i> -value curtain wall $U_{cw} = 2,0$ W/(m <sup>2</sup> ·K)			

## Annex G (normative)

### Parallel routes in normative references

This International Standard contains specific parallel routes in referencing to other international standards, in order to take into account existing national and/or regional regulations and/or legal environments while maintaining global relevance.

The standards that shall be used as called for in the successive clauses are given in Table G.1.

**Table G.1 — Normative references**

Clause (in this International Standard)	Subject	CEN area <sup>a</sup>	Elsewhere
Introduction	Thermal transmission: - glazing	EN 673:2011 EN 674:2011 EN 675:2011	ISO 10292:1994 ISO 10291:1994 ISO 10293:1997
6.2.1	Thermal transmission: - glazing	EN 673:2011 EN 674:2011 EN 675:2011	ISO 10292:1994 ISO 10291:1994 ISO 10293:1997
6.3.3	Thermal transmission: - glazing	EN 673:2011 EN 674:2011 EN 675:2011	ISO 10292:1994 ISO 10291:1994 ISO 10293:1997
7	Thermal transmission: - glazing	EN 673:2011 EN 674:2011 EN 675:2011	ISO 10292:1994 ISO 10291:1994 ISO 10293:1997
Annex A	Thermal transmission: - glazing	EN 673:2011 EN 674:2011 EN 675:2011	ISO 10292:1994 ISO 10291:1994 ISO 10293:1997
<sup>a</sup> CEN area = Countries whose national standards body is a member of CEN. Attention is drawn to the need for observance of EU Directives transposed into national legal requirements. Existing national regulations with or without reference to national standards may restrict, for the time being, the implementation of European standards			

## Bibliography

- [1] ISO 10456:2007, *Building materials and products — Hygrothermal properties — Tabulated design values and procedures for determining declared and design thermal values*
- [2] *U<sub>F</sub>-values for thermal break metal profiles of window systems*, ift Guideline WA-01engl/2, ift Rosenheim, February 2005
- [3] *U<sub>F</sub>-values for PVC profile sections of window systems*, ift Guideline WA-02engl/3, ift Rosenheim, February 2005
- [4] *U<sub>F</sub>-values for thermal break metal profile of facade systems*, ift Guideline WA-03engl/3, ift Rosenheim, February 2005

---

---

**ICS 91.120.10**

Price based on 49 pages