**Glass in building — Laminated glass and
laminated safety glass —**

**Part 5:
Dimensions and edge finishing**

*Verre dans la construction — Verre feuilleté et verre feuilleté de
sécurité —*

Partie 5: Dimensions et façonnage des bords



Reference number
ISO 12543-5:2011(E)



COPYRIGHT PROTECTED DOCUMENT

© ISO 2011

All rights reserved. Unless otherwise specified, no part of this publication may be reproduced or utilized in any form or by any means, electronic or mechanical, including photocopying and microfilm, without permission in writing from either ISO at the address below or ISO's member body in the country of the requester.

ISO copyright office
Case postale 56 • CH-1211 Geneva 20
Tel. + 41 22 749 01 11
Fax + 41 22 749 09 47
E-mail copyright@iso.org
Web www.iso.org

Published in Switzerland

Foreword

ISO (the International Organization for Standardization) is a worldwide federation of national standards bodies (ISO member bodies). The work of preparing International Standards is normally carried out through ISO technical committees. Each member body interested in a subject for which a technical committee has been established has the right to be represented on that committee. International organizations, governmental and non-governmental, in liaison with ISO, also take part in the work. ISO collaborates closely with the International Electrotechnical Commission (IEC) on all matters of electrotechnical standardization.

International Standards are drafted in accordance with the rules given in the ISO/IEC Directives, Part 2.

The main task of technical committees is to prepare International Standards. Draft International Standards adopted by the technical committees are circulated to the member bodies for voting. Publication as an International Standard requires approval by at least 75 % of the member bodies casting a vote.

Attention is drawn to the possibility that some of the elements of this document may be the subject of patent rights. ISO shall not be held responsible for identifying any or all such patent rights.

ISO 12543-5 was prepared by Technical Committee ISO/TC 160, *Glass in building*, Subcommittee SC 1, *Product considerations*.

This second edition cancels and replaces the first edition (ISO 12543-5:1998), which has been technically revised.

ISO 12543 consists of the following parts, under the general title *Glass in building — Laminated glass and laminated safety glass*:

- *Part 1: Definitions and description of component parts*
- *Part 2: Laminated safety glass*
- *Part 3: Laminated glass*
- *Part 4: Test methods for durability*
- *Part 5: Dimensions and edge finishing*
- *Part 6: Appearance*

Copyright International Organization for Standardization

Glass in building — Laminated glass and laminated safety glass —

Part 5: Dimensions and edge finishing

1 Scope

This part of ISO 12543 specifies dimensions, limit deviations and edge finishes of laminated glass and laminated safety glass for use in building.

This part of ISO 12543 is not applicable to panes having an area less than 0,05 m².

2 Normative references

The following referenced documents are indispensable for the application of this document. For dated references, only the edition cited applies. For undated references, the latest edition of the referenced document (including any amendments) applies.

ISO 12543-1, *Glass in building — Laminated glass and laminated safety glass — Part 1: Definitions and description of component parts*

3 Terms and definitions

For the purposes of this document, the terms and definitions given in ISO 12543-1 and the following apply.

3.1 displacement

d
misalignment at any one edge of the constituent glass panes or plastic glazing sheet material making up the laminated glass

See Figure 2.

4 Dimensions and limit deviations

4.1 Thickness

4.1.1 Nominal thickness

The nominal thickness of laminated glass shall be the sum of the nominal thicknesses of the constituent panes of glass, plastic glazing sheet material and the interlayers.

4.1.2 Limit deviation on thickness

4.1.2.1 Limit deviation on thickness of folio laminated products

The limit deviations on thickness of laminated glass shall not exceed the sum of the limit deviations of the constituent glass panes specified in the basic products standards; see ISO 12543-1:2011, Annex A.

NOTE 1 For the appropriate CEN standards, see ISO 12543-1:2011, Annex B.

If the total interlayer thickness is less than or equal to 2 mm, an additional limit deviation of $\pm 0,1$ mm applies. If the total interlayer thickness is greater than 2 mm, an additional limit deviation of $\pm 0,2$ mm shall apply.

The thickness limit deviation for plastic glazing sheet material shall be assumed to be the same as a float glass of the same nominal thickness.

NOTE 2 If the plastic glazing sheet material is covered by a standard, the actual limit deviations on thickness can be used.

EXAMPLE A laminated glass made from two sheets of float glass of 3 mm nominal thickness and a folio interlayer of 0,5 mm. The limit deviation of 3 mm float glass is given as $\pm 0,2$ mm and the limit deviation of the folio interlayer is $\pm 0,1$ mm. Therefore, the nominal thickness is 6,5 mm and the limit deviation is $\pm 0,5$ mm.

4.1.2.2 Limit deviations on thickness of cast-in-place products

The limit deviations on thickness of cast-in-place laminated glass shall not exceed the sum of the limit deviations of the constituent glass panes specified in the basic products standards and the limit deviations of the cast-in-place interlayers.

The thickness limit deviation for plastic glazing sheet material shall be assumed to be the same as a float glass of the same nominal thickness.

NOTE If the plastic glazing sheet material is covered by a standard, the actual limit deviations on thickness can be used.

The thickness limit deviations of cast-in-place interlayers shall be in accordance with Table 1.

Table 1 — Limit deviations on thickness of cast-in-place interlayers

Dimensions in millimetres	
Interlayer thickness	Limit deviation
<1	$\pm 0,4$
≥ 1 to <2	$\pm 0,5$
≥ 2 to <3	$\pm 0,6$
≥ 3	$\pm 0,7$

EXAMPLE A laminated glass made from two sheets of float glass of 3 mm nominal thickness and a cast-in-place interlayer of 1,5 mm. The limit deviation of 3 mm float glass is given as $\pm 0,2$ mm and from Table 1 the interlayer tolerance is $\pm 0,5$ mm. Therefore, the nominal thickness is 7,5 mm and the limit deviation is $\pm 0,9$ mm.

4.1.2.3 Limit deviations on thickness of fire-resistant laminated glass

The limit deviations on thickness of fire-resistant laminated glass shall not exceed the sum of the limit deviations of the constituent glass panes specified in the basic products standards and the limit deviations of the fire-resistant interlayers.

The thickness limit deviation for plastic glazing sheet material shall be assumed to be the same as a float glass of the same nominal thickness.

NOTE If the plastic glazing sheet material is covered by a standard, the actual limit deviations on thickness can be used.

For the fire-resistant interlayers of fire-resistant laminated glass, the limit deviations shall be in accordance with Table 2.

Table 2 — Limit deviations on thickness of fire-resistant interlayer

Dimensions in millimetres	
Interlayer thickness	Limit deviation
<1	±0,4
≥1 to <2	±0,5
≥2 to <5	±0,6
≥5	±1,0

4.1.2.4 Limit deviations on thickness of combinations

For laminated glass comprising different kinds of interlayers the limit deviation on thickness of the laminated glass shall be the sum of the allowed limit deviations of the constituent glass panes and the square root of the sum of the squares of the interlayer limit deviations, rounded to the nearest 0,1 mm.

EXAMPLE A laminated glass made from four sheets of float glass of nominal thickness 3 mm, a folio interlayer of 0,5 mm thickness and two fire-resistant interlayers of 1,5 mm thickness:

Nominal thickness: $4 \times 3 \text{ mm} + 0,5 \text{ mm} + 2 \times 1,5 \text{ mm} = 15,5 \text{ mm}$

Limit deviation: $4 \times (\pm 0,2 \text{ mm}) \pm \sqrt{0,1^2 \text{ mm} + 0,5^2 \text{ mm} + 0,5^2 \text{ mm}} = \pm 0,8 \text{ mm} \pm 0,714 \text{ mm} = \pm 1,5 \text{ mm}$

4.1.3 Measurement of thickness

The thickness of the pane shall be calculated as the mean of measurements taken at the centres of the four sides. The measurements shall be taken to an accuracy of 0,01 mm and the mean is then rounded to the nearest 0,1 mm.

The individual measurements, when rounded to the nearest 0,1 mm, shall also be within the limit deviations.

For laminated glass incorporating patterned glass, the measurement shall be made by means of an instrument of the plate gauge type with a diameter of $55 \text{ mm} \pm 5 \text{ mm}$.

4.2 Width, L , and length, H

4.2.1 General

When laminated glass sizes are quoted for rectangular panes, the first dimension shall be the width, L , and the second dimension the length, H , as shown in Figure 1.

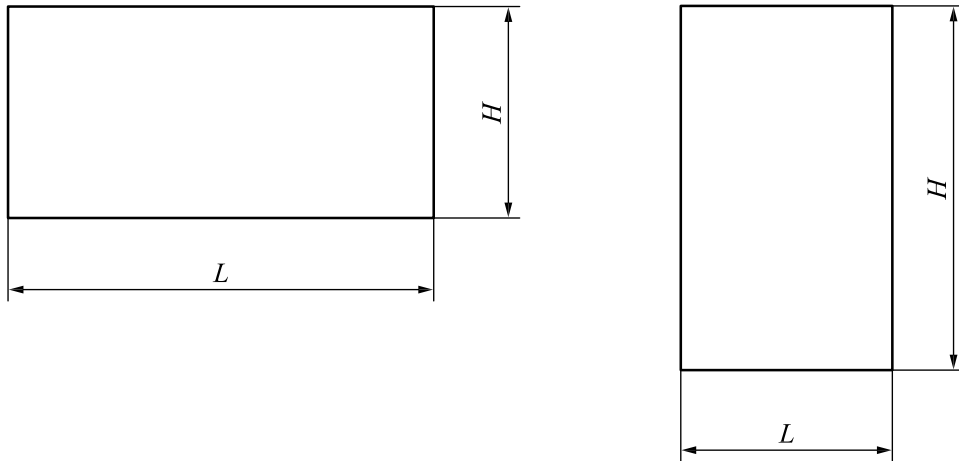

Figure 1 — Width and length relative to pane shape

The maximum width and length of laminated glass are dependent on the constituent glass and interlayers used in its composition and on the manufacturing plant of each individual manufacturer. Each manufacturer should indicate the maximum and minimum size they can produce.

Dimensions shall be given in millimetres. Each dimension shall be within the specified limit deviations.

4.2.2 Methods of measuring dimensions and squareness

The pane of glass shall not be larger than the nominal dimensions, given in accordance with 4.2.1, either increased by the upper limit deviation, t_1 , or smaller than the nominal dimensions decreased by the lower limit deviation, t_2 .

The squareness of rectangular glass panes is expressed by the difference between its diagonals.

The difference between the two diagonals shall not be larger than the limit deviation, v , as specified in Table 4.

4.2.3 Limit deviations on width, L , and length, H

Limit deviations on width, L , and length, H , are given in Table 3 for finished sizes and stock sizes. Any displacement shall be included in these limit deviations.

NOTE Displacement is covered in 4.2.4.

If one component of the laminated glass is a toughened or heat-strengthened glass an additional tolerance of ± 3 mm shall be taken into account.

Table 3 — Limit deviations, t_1 and t_2 , on width, L , and length, H , for finished and stock sizes

Dimensions in millimetres

Nominal dimension L or H	Nominal thickness of laminated glass ≤ 8 mm	Nominal thickness of laminated glass > 8 mm	
		Each glass pane < 10 mm nominal thickness	At least one glass pane ≥ 10 mm nominal thickness
$\leq 2\ 000$	+3,0	+3,5	+5,0
	-2,0	-2,0	-3,5
$\leq 3\ 000$	+4,5	+5,0	+6,0
	-2,5	-3,0	-4,0
$> 3\ 000$	+5,0	+6,0	+7,0
	-3,0	-4,0	-5,0

The limit deviations given in Table 3 do not apply for fire-resistant laminated glass and fire-resistant laminated safety glass. In these cases, the manufacturer shall specify the limit deviations. The limit deviations, v , for the difference between diagonals are given in Table 4.

Table 4 — Limit deviations, v , on the difference between diagonals

Dimensions in millimetres

Nominal dimension L or H	Nominal thickness of laminated glass ≤ 8 mm	Nominal thickness of laminated glass > 8 mm	
		Each glass pane < 10 mm nominal thickness	At least one glass pane ≥ 10 mm nominal thickness
$< 2\ 000$	6	7	9
$< 3\ 000$	8	9	11
$> 3\ 000$	10	11	13

4.2.4 Displacement

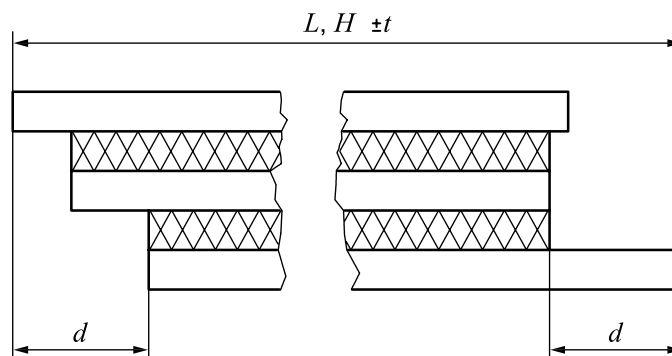

Figure 2 — Displacement

The maximum displacement, d , shall be as specified in Table 5. Width, L , and length, H , shall be considered separately.

Table 5 — Maximum displacement, d , for cut sizes and stock sizes

Dimensions in millimetres

Nominal dimension L or H	Maximum permissible displacement d
$L, H \leq 1\ 000$	2,0
$1\ 000 < L, H \leq 2\ 000$	3,0
$2\ 000 < L, H \leq 4\ 000$	4,0
$L, H > 4\ 000$	6,0

5 Edge finishes

5.1 General

Thermally treated glasses shall not be cut, sawn, drilled or edge worked after making into a laminate.

NOTE Thermally toughened safety glass, heat-soaked thermally toughened safety glass and heat-strengthened glass can be individually worked prior to thermal treatment in accordance with an applicable standard. The edges of fire-resistant laminated glass and fire-resistant laminated safety glass can be protected by an adhesive tape.

5.2 Cut edge

These are either originally cut edges of the constituent glass panes not subsequently worked (see Figure 3), or the edges of the laminated glass which have been cut and not subsequently worked (see Figure 4).

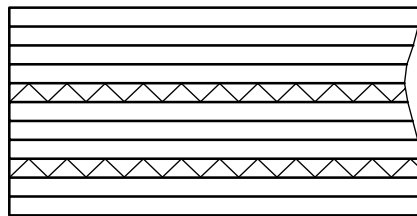

Figure 3 — Cut edge produced by the individual cut edges of the constituent glass panes which are not subsequently worked

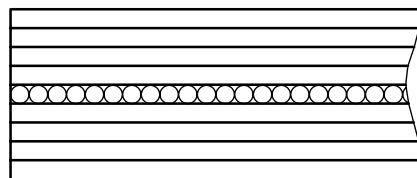

Figure 4 — Cut edge of cut laminated glass which is not subsequently worked

5.3 Worked edges

5.3.1 Arrissed edge

The originally cut edges of the outer glass panes of the laminated glass shall be ground off (see Figure 5).

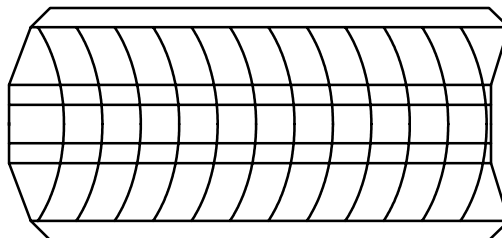

Figure 5 — Arrissed edge

5.3.2 Ground edge

The glass shall be arrissed and flat ground (see Figure 6).

NOTE Some bright areas can still exist on the edge face.

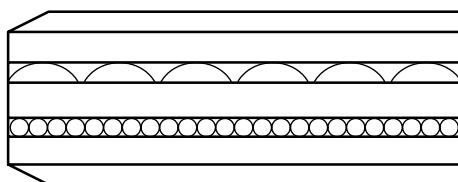

Figure 6 — Ground edge

5.3.3 Smooth ground edge

The edge face of the arrissed glass shall be ground and then smoothed with a finer grit than is used for ground edges and all bright areas shall be removed (see Figure 7).

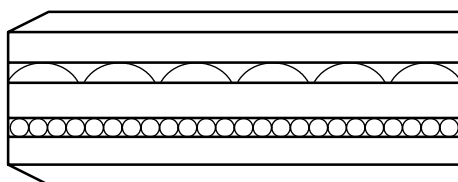

Figure 7 — Smooth ground edge

5.3.4 Polished edge

The previously smooth ground edge shall be polished in order to obtain a high lustre on the arressed and smoothed edges' surface (see Figure 8).

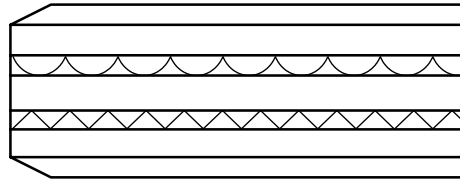

Figure 8 — Polished edge

5.3.5 Bevel edge

A bevel edge shall be a smooth ground or polished edge with an angle not exceeding 60°. The limit deviation on a bevel angle shall be ±3° (see Figure 9).

For greater angles and their limit deviations, the manufacturer should be contacted.

The nominal dimension, *L* or *H*, shall be reduced by 2 mm to 3 mm to cater for an arressed edge.

Dimensions in millimetres

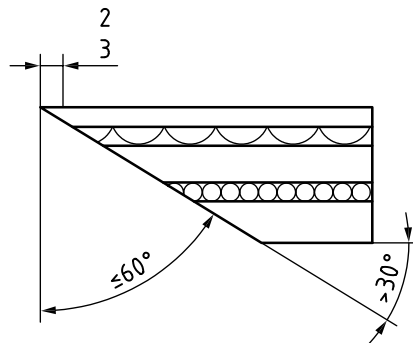

Figure 9 — Bevel edge

5.3.6 Sawn edge

A sawn edge shall be obtained by cutting with a saw.

NOTE The appearance is similar to ground edges, but without bright spots and arissing.

5.3.7 Water jet cut edge

A water jet cut edge shall be obtained by cutting with a water jet.

NOTE The appearance is similar to ground edges, but without bright spots and arissing.

6 Flatness

The flatness of laminated glass is dependent on the flatness of the constituent parts and can be influenced by the manufacturing conditions.

For the flatness of final cut sizes of folio laminated glass, ask the manufacturer.

ICS 81.040.20

Price based on 9 pages