Plywood — Bonding quality —
Part 1:
Test methods

Contreplaqué — Qualité du collage —
Partie 1: Méthodes d'essai



PDF disclaimer

This PDF file may contain embedded typefaces. In accordance with Adobe's licensing policy, this file may be printed or viewed but shall not be edited unless the typefaces which are embedded are licensed to and installed on the computer performing the editing. In downloading this file, parties accept therein the responsibility of not infringing Adobe's licensing policy. The ISO Central Secretariat accepts no liability in this area.

Adobe is a trademark of Adobe Systems Incorporated.

Details of the software products used to create this PDF file can be found in the General Info relative to the file; the PDF-creation parameters were optimized for printing. Every care has been taken to ensure that the file is suitable for use by ISO member bodies. In the unlikely event that a problem relating to it is found, please inform the Central Secretariat at the address given below.



COPYRIGHT PROTECTED DOCUMENT

© ISO 2007

All rights reserved. Unless otherwise specified, no part of this publication may be reproduced or utilized in any form or by any means, electronic or mechanical, including photocopying and microfilm, without permission in writing from either ISO at the address below or ISO's member body in the country of the requester.

ISO copyright office
Case postale 56 • CH-1211 Geneva 20
Tel. + 41 22 749 01 11
Fax + 41 22 749 09 47
E-mail copyright@iso.org
Web www.iso.org

Published in Switzerland



Contents

Page

Foreword.....	iv
1 Scope	1
2 Normative references	1
3 Test pieces	1
3.1 Sampling.....	1
3.2 Shape and size	1
4 Apparatus	5
4.1 Pre-treatment.....	5
4.2 Shear test.....	5
5 Pre-treatment.....	5
5.1 Sequence of pre-treatment	5
5.2 Positioning of test pieces	5
6 Procedure	6
6.1 Determination of behaviour of ply bonding by shear test.....	6
6.2 Determination of percentage of apparent cohesive wood failure	6
6.3 Alternative procedure.....	6
7 Expression of results	6
8 Test report	7
Annex A (normative) Determination of percentage of apparent cohesive wood failure by comparison with reference illustrations.....	8
Annex B (normative) Bond testing and evaluation using the chisel/knife testing procedures (suitable for quality control purposes only)	12
Bibliography	16



Foreword

ISO (the International Organization for Standardization) is a worldwide federation of national standards bodies (ISO member bodies). The work of preparing International Standards is normally carried out through ISO technical committees. Each member body interested in a subject for which a technical committee has been established has the right to be represented on that committee. International organizations, governmental and non-governmental, in liaison with ISO, also take part in the work. ISO collaborates closely with the International Electrotechnical Commission (IEC) on all matters of electrotechnical standardization.

International Standards are drafted in accordance with the rules given in the ISO/IEC Directives, Part 2.

The main task of technical committees is to prepare International Standards. Draft International Standards adopted by the technical committees are circulated to the member bodies for voting. Publication as an International Standard requires approval by at least 75 % of the member bodies casting a vote.

Attention is drawn to the possibility that some of the elements of this document may be the subject of patent rights. ISO shall not be held responsible for identifying any or all such patent rights.

ISO 12466-1 was prepared by Technical Committee ISO/TC 89, *Wood-based panels*, Subcommittee SC 3, *Plywood*.

This second edition cancels and replaces the first edition (ISO 12466-1:1999), which has been technically revised.

ISO 12466 consists of the following parts, under the general title *Plywood — Bonding quality*:

- *Part 1: Test methods*
- *Part 2: Requirements*



Plywood — Bonding quality —

Part 1: Test methods

1 Scope

This part of ISO 12466 specifies methods for determining the bonding quality of plywood, blockboard, battenboard, and laminboard, bonded with thermosetting resin, by shear testing.

NOTE If it is possible to demonstrate a correlation between the methods defined in this part of ISO 12466 and other methods, these may be used.

2 Normative references

The following referenced documents are indispensable for the application of this document. For dated references, only the edition cited applies. For undated references, the latest edition of the referenced document (including any amendments) applies.

ISO 12466-2, *Plywood — Bonding quality — Part 2: Requirements*

ISO 16999, *Wood-based panels — Sampling and cutting of test pieces*

3 Test pieces

3.1 Sampling

Sampling shall be in accordance with ISO 16999.

Test pieces shall be without any visible defect in the testing area.

3.2 Shape and size

The test pieces shall be prepared as shown in Figures 1, 2 and 3.

Each test piece shall be cut so that the grain direction of the layer (ply) between the glue lines under test is perpendicular to the length of the test piece.

The test pieces shall be prepared and nicking (saw cuts) made to allow the examination of each glue line of the panel. The saw cuts shall extend inside the layer.

Test pieces of full-panel thickness may be used for panels with three to nine layers (plies). For panels of more than nine layers, excess layers shall be removed by planing, cutting or sanding.



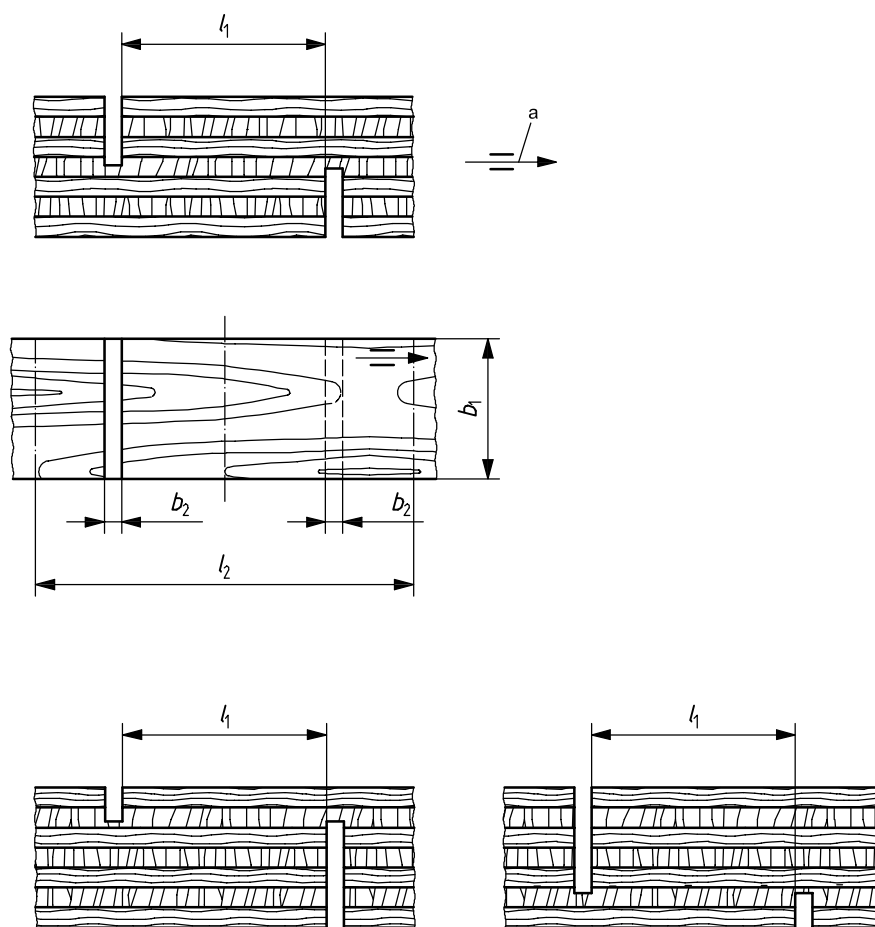

Key

- $b_1 = (25 \pm 0,5)$ mm shear width (width of test piece)
- $b_2 = 2,5$ mm to 4 mm saw cut width
- $l_1 = (25 \pm 0,5)$ mm shear length
- $l_2 = 50$ mm minimum distance between clamps
- thickness = panel thickness

^a Along the grain direction.

Figure 1 — Test piece example for a 7-ply veneer plywood



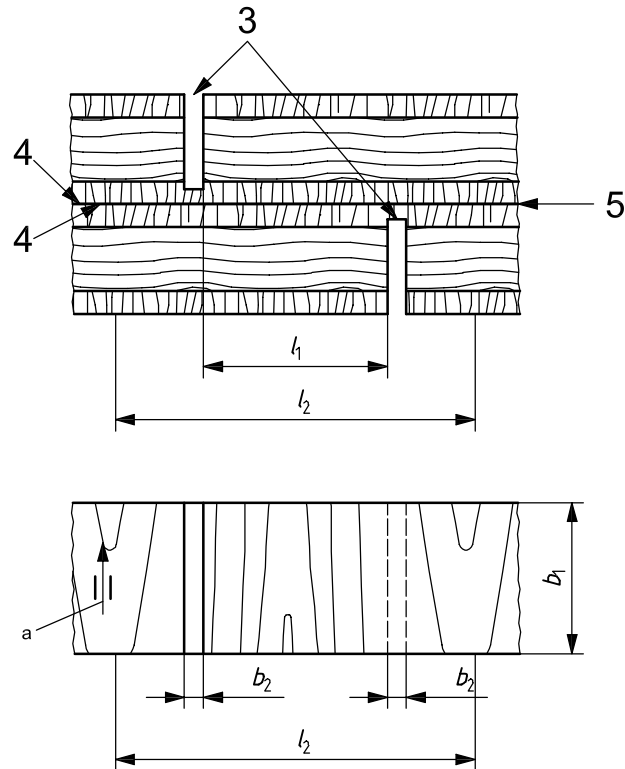
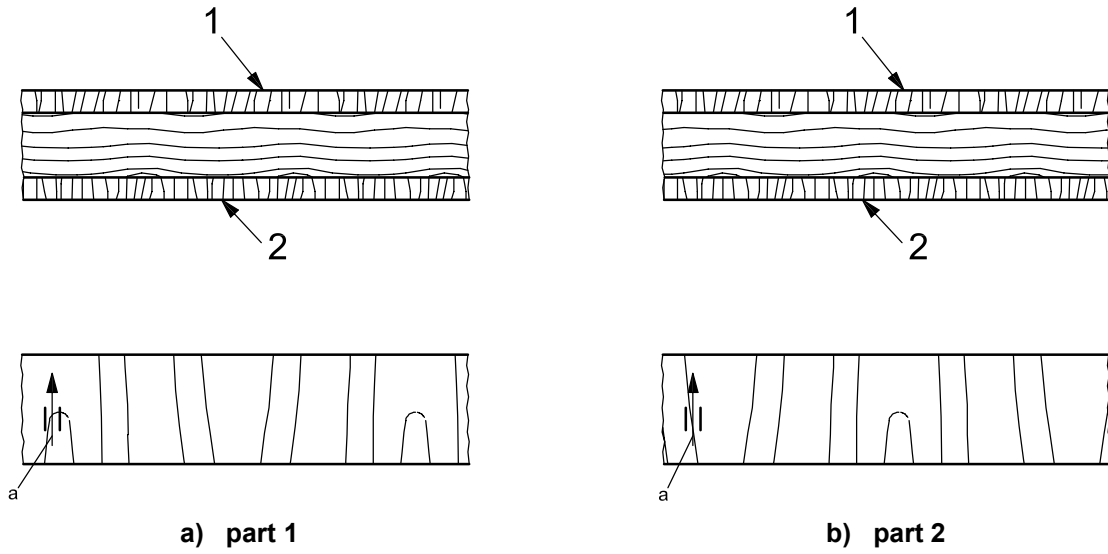

Key

- 1 face
- 2 back face
- 3 saw cuts throughout the face layers
- 4 faces of part 1 and part 2^b
- 5 glue-line not subject to the shear test
- $b_1 = (25 \pm 0,5)$ mm shear width
- $b_2 = 2,5$ mm to 4 mm saw cut width
- $l_1 = (25 \pm 0,5)$ mm shear length
- $l_2 = 50$ mm minimum distance between clamps

a Along the grain direction.

b The same set up shall be made for the back face of part 1 and part 2.

Figure 2 — Composite test piece for blockboard and laminboard

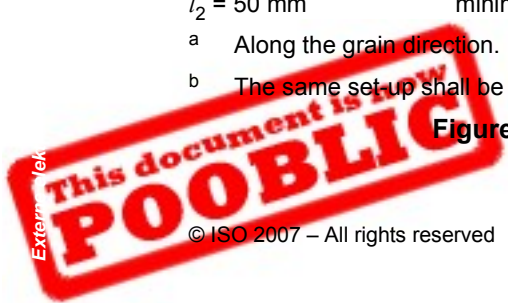

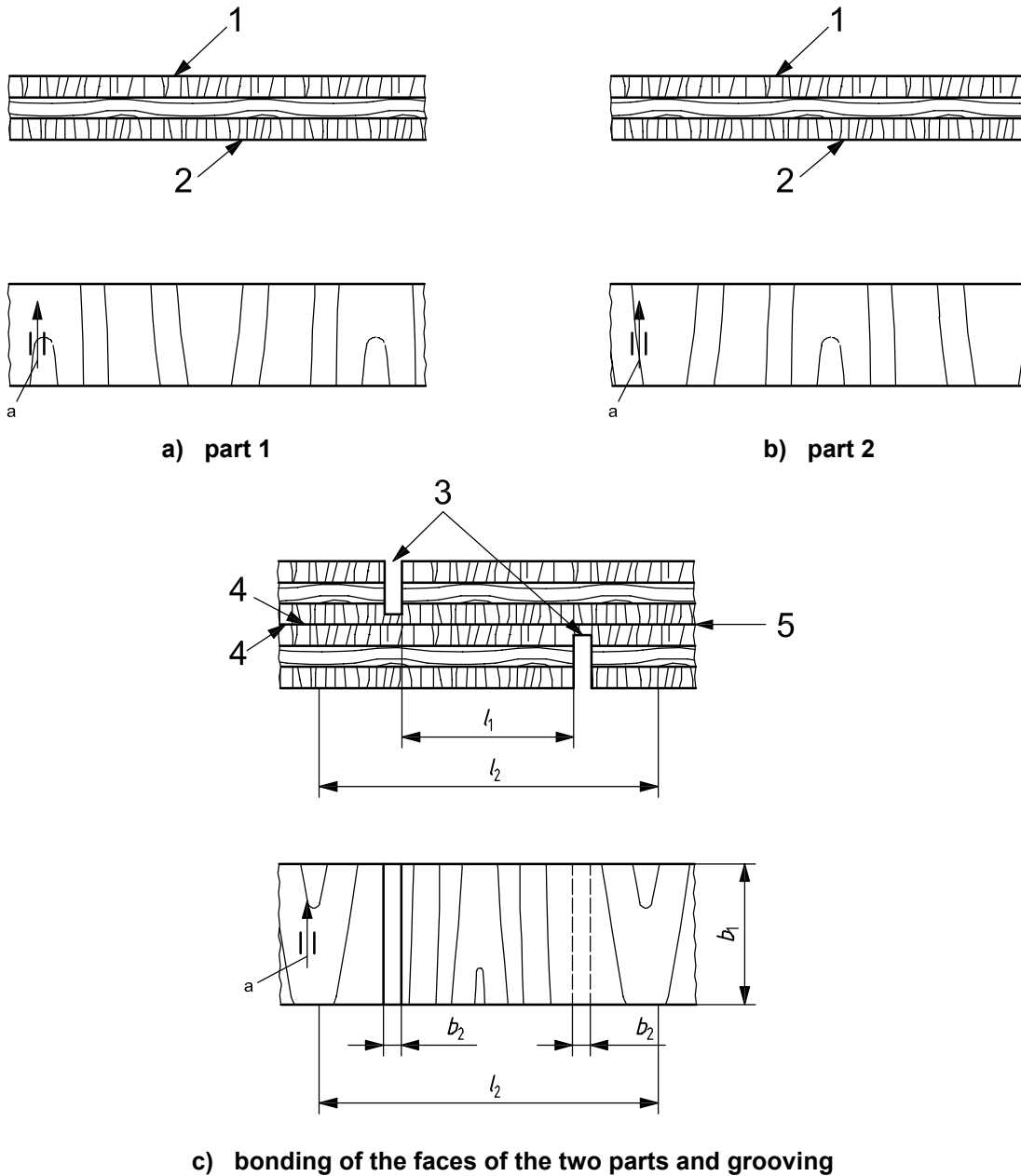

Key

- 1 face
- 2 back face
- 3 saw cuts throughout the face layers
- 4 faces of part 1 and part 2^b
- 5 glue-line not subject to the shear test
- $b_1 = (25 \pm 0,5)$ mm shear width
- $b_2 = 2,5$ mm to 4 mm saw cut width
- $l_1 = (25 \pm 0,5)$ mm shear length
- $l_2 = 50$ mm minimum distance between clamps

a Along the grain direction.

b The same set-up shall be made for the back face of part 1 and part 2.

Figure 3 — Composite test piece for thin-face plywood panel



4 Apparatus

4.1 Pre-treatment

4.1.1 Temperature-controlled water bath suitable for immersing test pieces and capable of maintaining a minimum temperature of 17 °C.

4.1.2 Boiling tank enabling test pieces to be immersed in boiling water.

4.1.3 Ventilated drying oven capable of maintaining a temperature of (60 ± 3) °C at all points.

4.1.4 Vacuum pressure chamber capable of maintaining in water at room temperature a vacuum of 85 kPa for 30 min followed immediately by application of pressure of 450 kPa to 480 kPa for 30 min.

4.1.5 Autoclave capable of maintaining steam pressure at (200 ± 7) kPa for $6 \text{ h} \pm 15 \text{ min}$.

4.2 Shear test

Tensile testing machine fitted with serrated wedge action grips, capable of operating continuously and measuring the load to an accuracy: $\pm 1 \%$.

5 Pre-treatment

5.1 Sequence of pre-treatment

The choice of pre-treatment, described in 5.1.1 to 5.1.6, for particular plywood classes, shall be made in accordance with ISO 12466-2.

5.1.1 24 h Cold soak: immersion for 24 h in water at a temperature not lower than 17 °C.

NOTE (20 ± 3) °C can be considered as a test reference temperature.

5.1.2 6 h Boil: immersion for 6 h in boiling water, followed by cooling in water at less than 30 °C for at least 1 h.

5.1.3 BDB: immersion for 4 h in boiling water, then drying in the ventilated drying oven for 16 h to 20 h at (60 ± 3) °C, then immersion in boiling water for 4 h, followed by cooling in water at less than 30 °C for at least 1 h.

5.1.4 VP: test specimens are immersed in water at room temperature and a vacuum of 85 kPa is applied for 30 min followed by the immediate application of a pressure of 450 kPa to 480 kPa for 30min.

5.1.5 72 h Boil: immersion for (72 ± 1) h in boiling water, followed by cooling in water at less than 30 °C for at least 1 h.

5.1.6 Steam: specimens are placed in steam at (200 ± 7) kPa pressure for $6 \text{ h} \pm 15 \text{ min}$ followed by cooling for at least 1 h in water at less than 30 °C.

5.2 Positioning of test pieces

The test pieces shall be placed, well separated and free to move, in a wire basket. During soaking, each test piece shall remain completely immersed in water.



6 Procedure

6.1 Determination of behaviour of ply bonding by shear test

Before the water treatment, measure the length and width of the shear area to an accuracy of 0,1 mm and record.

Arrange the shear test pieces in the centre of the clamping device in such a way that the load can be transmitted from the testing machine, via the ends of the test pieces, to the shear area without any transverse load. If slipping occurs, it shall only be allowed in the initial stage of the loading.

Apply the load at a constant speed so that failure occurs within (30 ± 10) s.

Determine and record the load at failure, to an accuracy of 1 %. Calculate the shear strength, in megapascals, in accordance with Clause 7.

After the shear test, determine the apparent cohesive wood failure in accordance with 6.2.

6.2 Determination of percentage of apparent cohesive wood failure

Allow the test pieces to dry before determination of apparent cohesive wood failure.

The percentage of apparent cohesive wood failure shall be determined by comparison with the standard illustrations in Annex A, by 10 % increments from 0 % to 100 %, and recorded.

Failure should normally occur in the wood or in the glue lines between the saw cuts, i.e. within the shear test area. If failure occurs outside the test area, or by cross-grain breaking within 50 % or more of the surface of a face veneer, reject the result and repeat the test with a shear length of 10 mm.

Failures resulting from the presence of strength-reducing defects shall also be excluded, with the exception of test pieces containing tape. Test pieces with such defects should normally be identified and replaced during the cutting operation. If the number of test pieces rejected exceeds 20 %, it is necessary to resample. If the re-sampling is also rejected on this basis, then the batch shall be rejected.

6.3 Alternative procedure

An alternative procedure for bond testing and evaluation, the knife or chisel test, is provided in Annex B. This procedure is deemed suitable for quality control purposes only.

7 Expression of results

Calculate the shear strength, τ , in megapascals, of each test piece, from Equation (1):

$$\tau = \frac{F}{lb} \quad (1)$$

where

F is the force (load), in newtons, at failure of the test piece;

l is the length, in millimetres, of the shear area;

b is the width, in millimetres, of the shear area.

Calculate the mean shear strength, to the nearest 0,01 MPa, and the standard deviation.

Also, determine the average percentage cohesive wood failure, to an accuracy of 10 %.

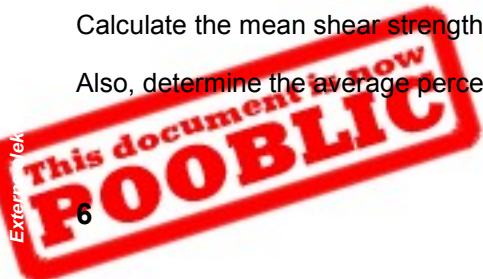

8 Test report

The test report shall be in accordance with ISO 16999, and shall also contain the following information:

- a) mean shear strength, in megapascals, and the standard deviation;
- b) average percentage apparent cohesive wood failure;
- c) details of pre-treatment (see 5.1);
- d) a reference to this part of ISO 12466.



Annex A (normative)

Determination of percentage of apparent cohesive wood failure by comparison with reference illustrations

Determine the percentage of apparent cohesive wood failure of the dried individual specimen to the nearest 10 % by comparison to the reference illustrations (see Figures A.1, A.2, and A3). The determination consists of an area assessment and a determination of the texture of the failure surface.

For photo technical reasons, the illustrations are intended for use only with plywood bonded with a brown glue.

In the determination of failure texture of both deep and superficial failures in the veneers, the same weighting shall be assigned as to apparent cohesive wood failures.

The texture of the broken surfaces shall be determined using the following guidelines:

- a) sufficient light should be available to appreciate the correct texture of the failure surfaces — a magnifying lens may also be of assistance;
- b) areas of the broken surfaces lying entirely in the veneer adjacent to the tested glue lines or areas of the tested glue lines covered with opaque bundles of fibres should count as apparent cohesive wood failure;
- c) a failure surface having a shaggy/downy appearance due to covering of the glue lines with fine fibres should count as apparent cohesive wood failure;
- d) a thin transparent layer of fibres on the glue line should also be counted as apparent cohesive wood failure, as long as the general appearance shows covering with fibres;
- e) glue visible through a covering of fine fibres should not be recorded as apparent cohesive wood failure;
- f) areas of the glue line, where no glue has been present at the time of bonding, should not be counted as apparent cohesive wood failure.

The determination of percentage of wood-fibre failure is subjective and is a skill not instantly acquired. While trained and experienced operators obtain accurate and reproducible results, differences between operators and laboratories may occur. To minimise this possibility, the above guidelines shall be observed.

NOTE Dispersion in interpretation of visual examination results can exceed 10 % in usual practice.



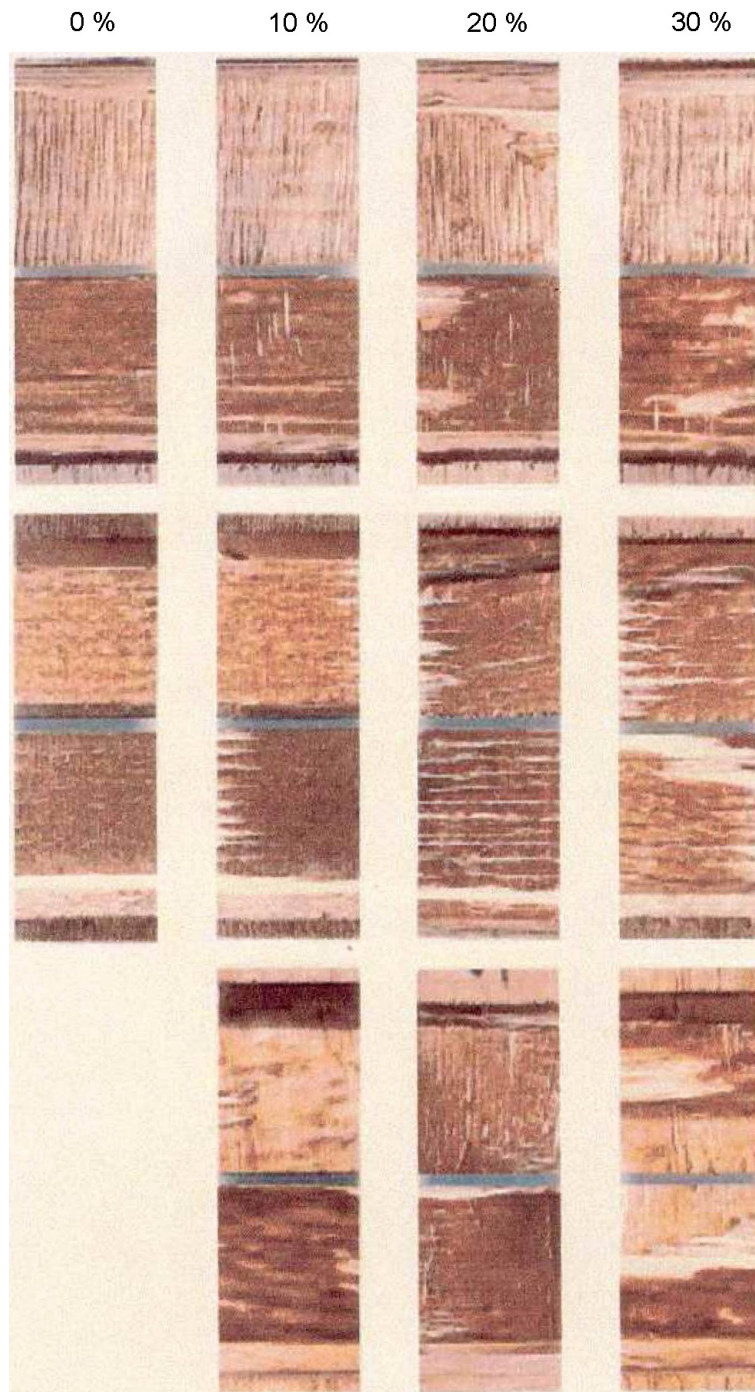

Figure A.1 — Reference illustrations — Wood fibre failure 0 % to 30 %

External
This document is now
POOBLIC
© ISO 2007 – All rights reserved

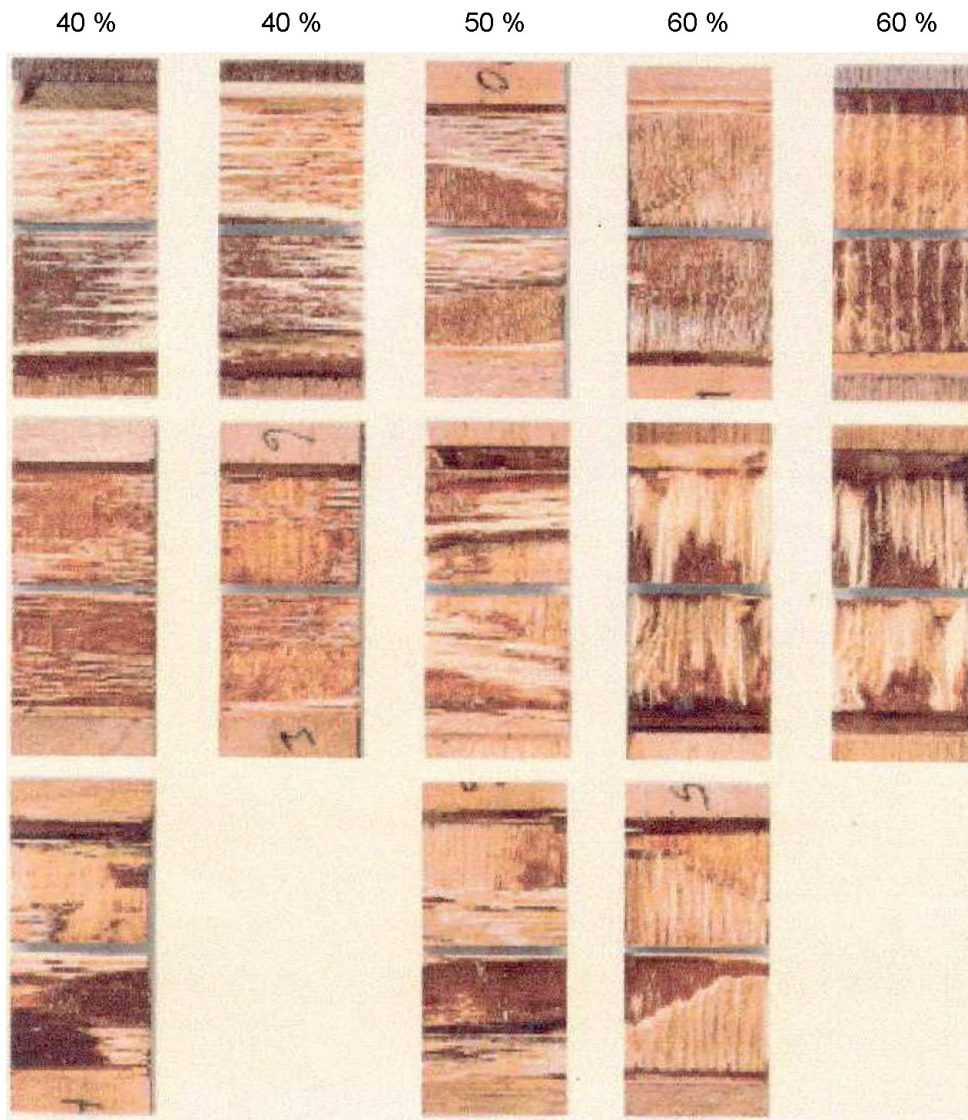

Figure A.2 — Reference illustrations — Wood fibre failure 40 % to 60 %

External
This document is now
POOBLIC
10

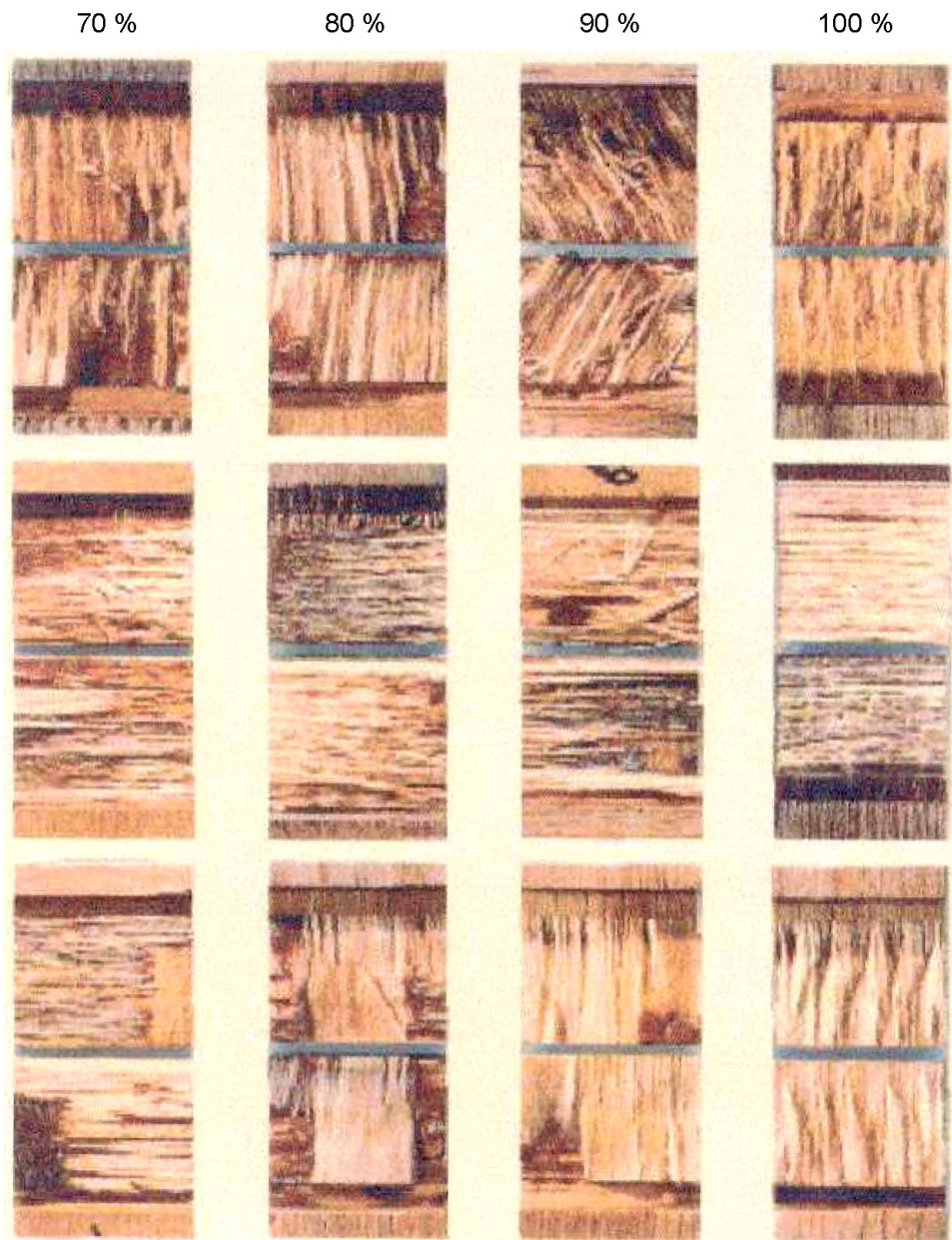

Figure A.3 — Reference illustrations — Wood fibre failure 70 % to 100 %

External
This document is now
POOBLIC
© ISO 2007 – All rights reserved

Annex B (normative)

Bond testing and evaluation using the chisel/knife testing procedures (suitable for quality control purposes only)

B.1 General

This alternative procedure for bond testing and evaluation (chisel/knife test) is deemed suitable for quality control purposes only. It is a stand-alone procedure and shall be used in full. The procedure cannot be combined with that specified in 6.1 and 6.2.

B.2 Principle

In a well-made glue line, the separation of plies occurs, predominantly, through breaking of the wood itself and not by separation of the plies along the glue line. A satisfactory glue line will therefore include a substantial amount of adhering wood fibre when the plies are forcibly separated. Consequently, the proportion of fractured wood adhering to both plies will provide a measure of the quality of the bond.

B.3 Test pieces

Each test piece shall be the full thickness of the sheet and a minimum of 150 mm long and 65 mm wide. Each test piece shall be marked to identify it with the sample sheet from which it was cut.

B.4 Apparatus

The following apparatus is required for all tests:

B.4.1 Chisel (knife), examples of which are shown in Figure B.1 and Figure B.2. The shape of the chisel or knife is not specified, but shall be such as to allow the implement to penetrate through the veneer into the glue line in a manner that will place the glue line under stress and cause a fracture in the vicinity of the glue line in the adhesive or the wood fibre.

NOTE The percussion chisel shown in Figure B.1 requires a percussion mechanism to assist in forcing the chisel along the glue line.

B.4.2 Bench with a timber backstop.

B.4.3 Light source fitted with a minimum clear incandescent 150 W lamp or a 15 W fluorescent tube.

If a fluorescent tube is used, a dual, cool white, and daylight tube is recommended.

B.4.4 Oven.

Either B.4.4.1. or B.4.4.2 may be used.

B.4.4.1 Oven, well-ventilated, with heat-emitting element(s), wire mesh shelves or other open material that allows free internal circulation of air, and capable of maintaining a temperature above 100 °C without degrading the specimen.



B.4.4.2 Microwave oven, equipped with a cooling fan and cavity air exhaust.

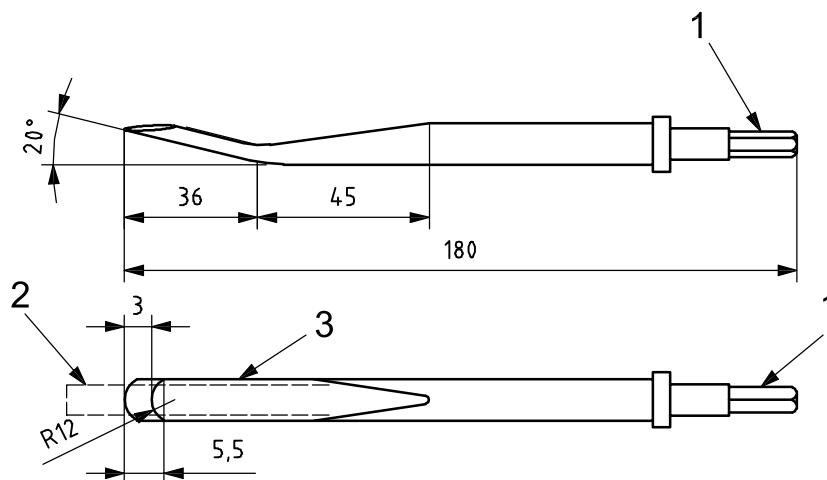

Key

- 1 hexagon shall have this orientation
- 2 original outline (see Note to B.4.1)
- 3 blade to be hot forged and hardened

Figure B.1 — Example of percussion chisel for bond testing of plywood

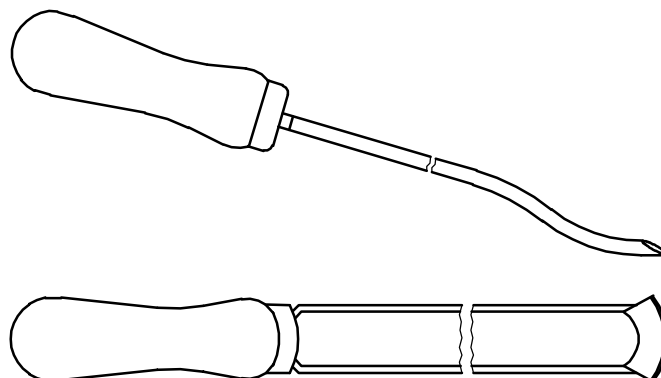

Figure B.2 — Example of hand chisel for bond testing of plywood

B.5 Procedure

The procedure shall take place while the plywood is in the wet state after the pre-treatment.

B.5.1 Remove the uppermost veneer of the test piece (see note 1) by forcing the chisel along the glue line in a direction perpendicular to the grain of that veneer by guiding the chisel forward 25 mm to 50 mm as nearly as practicable along the glue line (see note 2 and note 3).

NOTE 1 Instead of separating all the veneers of the one test piece, individual test pieces may be used for each glue line; thus for 3-ply, two test pieces should be cut from the sample sheet.

NOTE 2 The chisel may be applied to the surface of the test piece or to its edge at the glue line.

NOTE 3 A slight wriggle in the motion of the chisel should assist penetration.

B.5.2 Break the veneer with a lever action of the chisel.

NOTE When using a percussion chisel, the percussion action to penetrate the glue line may be used. Use the chisel in the 'dead' condition for the lever action for lifting and breaking the veneer.

B.5.3 Separate all the veneers of the test piece by repeating the procedures specified in B.5.1 and B.5.2, taking care not to remove any wood fibre adhering to previously exposed glue lines.

B.5.4 For wet test pieces, after exposing all of the glue lines as specified in B.5.1, B.5.2, and B.5.3, reassemble the separated plies in their original order and dry in an oven until all their surfaces appear dry, then evaluate the percentage of wood failure as described.

Rapid drying is necessary to avoid microbiological attack.

B.5.5 For dry test pieces, after exposing all of the glue lines as specified in B.5.1, B.5.2, and B.5.3, evaluate the percentage of wood failure as described.

B.5.6 Clearly record (if practicable, on the test piece) the assessment of the percentage wood failure in each glue line by the appropriate numeral.

B.6 Determination of apparent cohesive wood failure (bonding quality)

B.6.1 Lighting

The glue line to be evaluated shall be well lit with oblique light to show the full wood failure.

The angle of the incidence of the illumination should be 10° to 15°. A light source as specified in B.4.3 should be placed so that the incandescent lamp is between 125 mm and 275 mm from the test pieces or the fluorescent tube is between 25 mm and 75 mm from the test piece.

B.6.2 Examination

The percentage area of the glue line covered by wood, irrespective of the depth of wood failure, shall be evaluated. Areas where the chisel goes through the glue line and makes a clean cut in the ply, areas where the chisel obviously failed to find the glue line, and areas where faulty bond is due to permitted imperfections, e.g. knots and holes, shall be disregarded.

Any test piece containing more than 40 % of excluded area shall not be considered in the evaluation of bond quality, and such test piece shall be replaced.

In assessing wood failure, both sides of the glue line shall be evaluated.

B.6.3 Bonding quality scale

After evaluation of wood failure in accordance with B.6.2, a bonding quality value shall be allocated to each glue line as specified in Table B.1.



Table B.1 — Bonding quality scale

Estimated wood failure %	Bonding quality value
< 10	0
10	1
20	2
30	3
40	4
50	5
60	6
70	7
80	8
90	9
> 90	10

B.6.4 Calculation

The average bonding quality of each glue line in all test pieces from the same test sample shall be calculated.

B.7 Test report

The test report shall contain at least the following information:

- a) average bonding quality of each glue line of the test sample and the overall average bonding quality of the test sample;
- b) details of the pre-treatment (see 5.1);
- c) a reference to this part of ISO 12466;
- d) product source and description of test material;
- e) number of pieces tested per test sample;
- f) number of glue lines tested per test sample;
- g) any other information deemed relevant to bonding quality.



Bibliography

- [1] ISO 2074, *Plywood — Vocabulary*
- [2] ISO 12465, *Plywood — Specifications*



This page is intentionally blank.



This page is intentionally blank.



This page is intentionally blank.



ICS 79.060.10

Price based on 16 pages

© ISO 2007 – All rights reserved

