

---

---

**Wood-based panels — Determination of  
formaldehyde release —**

**Part 1:  
Formaldehyde emission by  
the 1-cubic-metre chamber method**

*Panneaux à base de bois — Détermination du dégagement de  
formaldéhyde —*

*Partie 1: Méthode du dégagement de formaldéhyde en chambre de  
1 mètre cube*



Reference number  
ISO 12460-1:2007(E)

© ISO 2007

**PDF disclaimer**

This PDF file may contain embedded typefaces. In accordance with Adobe's licensing policy, this file may be printed or viewed but shall not be edited unless the typefaces which are embedded are licensed to and installed on the computer performing the editing. In downloading this file, parties accept therein the responsibility of not infringing Adobe's licensing policy. The ISO Central Secretariat accepts no liability in this area.

Adobe is a trademark of Adobe Systems Incorporated.

Details of the software products used to create this PDF file can be found in the General Info relative to the file; the PDF-creation parameters were optimized for printing. Every care has been taken to ensure that the file is suitable for use by ISO member bodies. In the unlikely event that a problem relating to it is found, please inform the Central Secretariat at the address given below.



**COPYRIGHT PROTECTED DOCUMENT**

© ISO 2007

All rights reserved. Unless otherwise specified, no part of this publication may be reproduced or utilized in any form or by any means, electronic or mechanical, including photocopying and microfilm, without permission in writing from either ISO at the address below or ISO's member body in the country of the requester.

ISO copyright office  
Case postale 56 • CH-1211 Geneva 20  
Tel. + 41 22 749 01 11  
Fax + 41 22 749 09 47  
E-mail [copyright@iso.org](mailto:copyright@iso.org)  
Web [www.iso.org](http://www.iso.org)

Published in Switzerland

# Contents

Page

Foreword.....	iv
Introduction .....	v
1 Scope .....	1
2 Normative references .....	1
3 Terms and definitions.....	1
4 Principle .....	2
5 Reagents .....	3
6 Apparatus .....	3
7 Test pieces .....	9
8 Procedure .....	10
9 Determination of formaldehyde emission.....	12
10 Determination of steady-state emission value .....	15
11 Expression of results .....	15
12 Test report .....	16
<b>Annex A (informative) Analytical procedure for the fluorimetric determination of formaldehyde content .....</b>	<b>17</b>
<b>Bibliography .....</b>	<b>19</b>

## Foreword

ISO (the International Organization for Standardization) is a worldwide federation of national standards bodies (ISO member bodies). The work of preparing International Standards is normally carried out through ISO technical committees. Each member body interested in a subject for which a technical committee has been established has the right to be represented on that committee. International organizations, governmental and non-governmental, in liaison with ISO, also take part in the work. ISO collaborates closely with the International Electrotechnical Commission (IEC) on all matters of electrotechnical standardization.

International Standards are drafted in accordance with the rules given in the ISO/IEC Directives, Part 2.

The main task of technical committees is to prepare International Standards. Draft International Standards adopted by the technical committees are circulated to the member bodies for voting. Publication as an International Standard requires approval by at least 75 % of the member bodies casting a vote.

Attention is drawn to the possibility that some of the elements of this document may be the subject of patent rights. ISO shall not be held responsible for identifying any or all such patent rights.

ISO 12460-1 was prepared by Technical Committee ISO/TC 89, *Wood-based panels*.

ISO 12460 consists of the following parts, under the general title *Wood-based panels — Determination of formaldehyde release*:

- *Part 1: Formaldehyde emission by the 1-cubic-metre chamber method*
- *Part 2: Small-scale chamber method*
- *Part 3: Gas analysis method*
- *Part 4: Desiccator method*

## Introduction

The 1 m<sup>3</sup>-chamber is the reference method for the determination of formaldehyde release. For factory production control, the following regional or national derived test methods are used:

- perforator method, as described in EN 120;
- dessicator method, as described in ISO 12460-4;
- gas analysis method, as described in ISO 12460-3;
- flask method, as described in EN 717-3;
- small-chamber method, as described in ISO 12460-2 (ASTM D6007).

Round-robin tests have shown good correlations between the 1 m<sup>3</sup> chamber, and large and small test chambers.

\*\*\*\*\*

# Wood-based panels — Determination of formaldehyde release —

## Part 1: Formaldehyde emission by the 1-cubic-metre chamber method

### 1 Scope

This part of ISO 12460 specifies a 1 m<sup>3</sup> chamber method for the determination of the formaldehyde emission from wood-based panels under defined conditions, relating to typical conditions in real-life.

### 2 Normative references

The following referenced documents are indispensable for the application of this document. For dated references, only the edition cited applies. For undated references, the latest edition of the referenced document (including any amendments) applies.

ISO 16000-3, *Indoor air — Determination of formaldehyde and other carbonyl compounds — Active sampling method*

ISO 16999, *Wood-based panels — Sampling and cutting of test pieces*

### 3 Terms and definitions

For the purposes of this document, the following terms and definitions apply.

#### 3.1

##### **volume of the chamber**

total air volume of the unloaded chamber, including recirculating ventilation ducts

NOTE The volume of the chamber is expressed in units of cubic metres.

#### 3.2

##### **loading factor**

ratio of the total surface area of the test piece, excluding the area of the edges, to the volume of the chamber

NOTE The loading factor is expressed in units of square metres per cubic metre.

#### 3.3

##### **air exchange rate**

quotient of air volume going through the chamber per hour and the volume of the chamber

NOTE The air exchange rate is expressed in units of cubic metres of air per hour per cubic metre of volume of the chamber.

### 3.4

#### air velocity

velocity of the air near the surface of tested pieces in the chamber

NOTE The air velocity is expressed in units of metres per second.

### 3.5

#### steady-state

condition reached when the formaldehyde emission of the wood-based panels is quasi-constant under the test condition such that the formaldehyde concentration in the chamber remains constant

NOTE In practice, a true steady-state is not achievable because formaldehyde is emitted irreversibly. This part of ISO 12460 defines steady-state condition for the purpose of the test.

### 3.6

#### emission value

steady-state formaldehyde concentration in the chamber, obtained under constant temperature, relative humidity, loading factor and air exchange rate after a defined period of preconditioning

NOTE 1 The emission value is expressed in units of milligrams of formaldehyde per cubic metre air.

NOTE 2 At 23 °C and 1 013 hPa, the following relationships exist for the formaldehyde concentrations:

$$1 \text{ ppm}^1 \text{ (parts per million)} = 1,24 \text{ mg/m}^3;$$

$$1 \text{ mg/m}^3 = 0,81 \text{ ppm (parts per million)}.$$

## 4 Principle

Preconditioned test pieces of known surface area, are placed in a 1 m<sup>3</sup> chamber, in which the temperature, relative humidity, air velocity and exchange rate are controlled at defined values. Formaldehyde emitted from the test pieces mixes with the air in the chamber. The air in the chamber is sampled periodically over a defined period. The formaldehyde concentration is determined by drawing air from the chamber through gas washing bottles containing water, which absorbs the formaldehyde. The formaldehyde concentration in the water is determined. The concentration of formaldehyde in the chamber atmosphere is calculated from the concentration in the water in the gas washing bottles and the volume of the sampled air. It is expressed in milligrams per cubic metre (mg/m<sup>3</sup>). Sampling is periodically continued until the formaldehyde concentration in the chamber has reached a steady-state.

NOTE 1 The chamber method can also be used for the testing of formaldehyde emitting products other than wood-based panels.

NOTE 2 The influences of temperature, relative humidity, loading factor and air exchange rate on the formaldehyde concentration in the chamber atmosphere can be described by the Andersen formula<sup>[10]</sup>. An interrelation between the structure of the test pieces, especially of their surfaces and the air velocity is also apparent but cannot be exactly described by a formula.

---

1) "ppm" is a unit deprecated by ISO.



## 5 Reagents

Reagents and water of recognized analytical purity shall be used for the analysis.

### 5.1 Acetylacetone solution.

4 ml acetyl acetone are added to a 1 000 ml volumetric flask and made up to the mark with water.

### 5.2 Ammonium acetate solution.

200 g ammonium acetate are dissolved in water in a 1 000 ml volumetric flask and made up to the mark.

Commercially prepared solutions may be used.

### 5.3 Standard iodine solution, $c(I_2) = 0,05 \text{ mol/l}$ .

### 5.4 Standard sodium thiosulfate solution, $c(\text{Na}_2\text{S}_2\text{O}_3) = 0,1 \text{ mol/l}$ .

### 5.5 Standard sodium hydroxide solution, $c(\text{NaOH}) = 1 \text{ mol/l}$ .

### 5.6 Standard sulfuric acid solution, $c(\text{H}_2\text{SO}_4) = 1 \text{ mol/l}$ .

### 5.7 Starch solution, 1 % by mass.

## 6 Apparatus

### 6.1 Test chamber construction

#### 6.1.1 Chamber volume and operation

Chambers of this type have a total volume of  $1 \text{ m}^3$  and are operated with intensive circular air flow; see Figures 1, 2 and 3.

The climatic test conditions (temperature and relative humidity) are established by using preconditioned inlet air. It is necessary that chambers operated in this way have effective wall insulation.

The conditioning devices and the chamber should be operated under conditions, where condensation of water cannot occur on surfaces, i.e. the air temperature is kept above its dew point.

The temperature within the test chamber can also be established by placing the chamber in a larger compartment with controlled temperature. Test chambers operated in this way shall have no insulation.

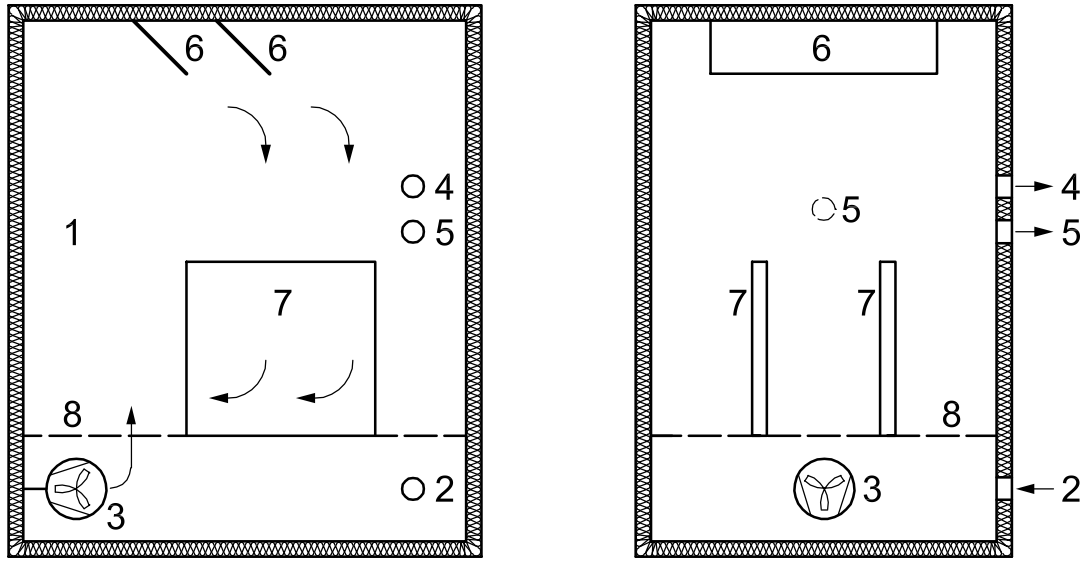

**Key**

- |   |  |   |                   |
|---|--|---|-------------------|
| 1 | 1 m <sup>3</sup> test chamber          | 5 | air outlet        |
| 2 | air inlet                              | 6 | baffle plates     |
| 3 | ventilation fan                        | 7 | test pieces       |
| 4 | inlet for monitoring equipment/sensors | 8 | perforated bottom |

**Figure 1 — Construction scheme for a 1 m<sup>3</sup> test chamber — Example 1**

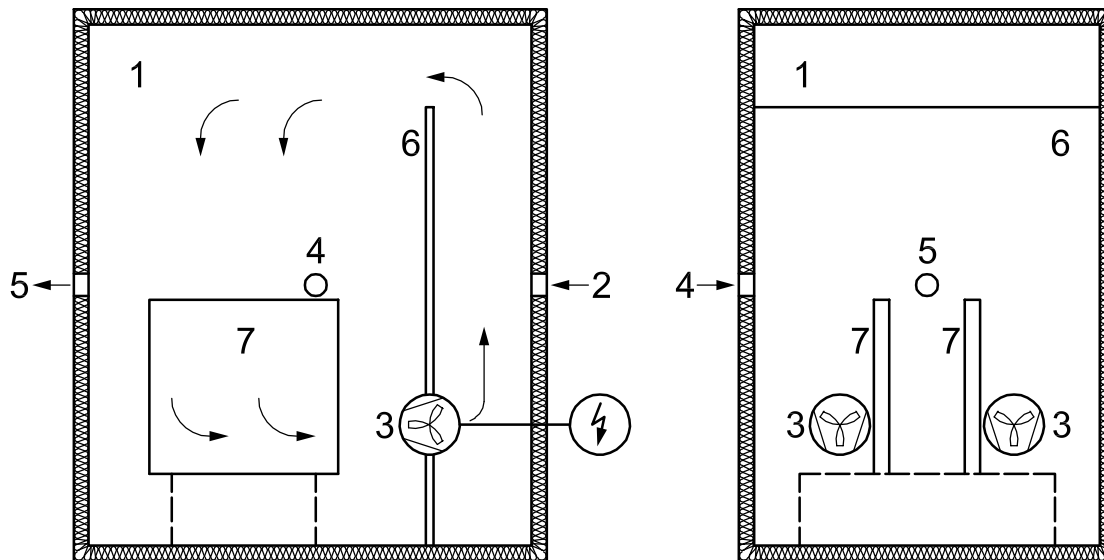

**Key**

- |   |  |   |             |
|---|--|---|-------------|
| 1 | 1 m <sup>3</sup> test chamber              | 5 | air outlet  |
| 2 | air inlet                                  | 6 | partition   |
| 3 | ventilation fan with electric power supply | 7 | test pieces |
| 4 | inlet for monitoring equipment/sensors     |   |             |

**Figure 2 — Construction scheme for a 1 m<sup>3</sup> test chamber — Example 2**

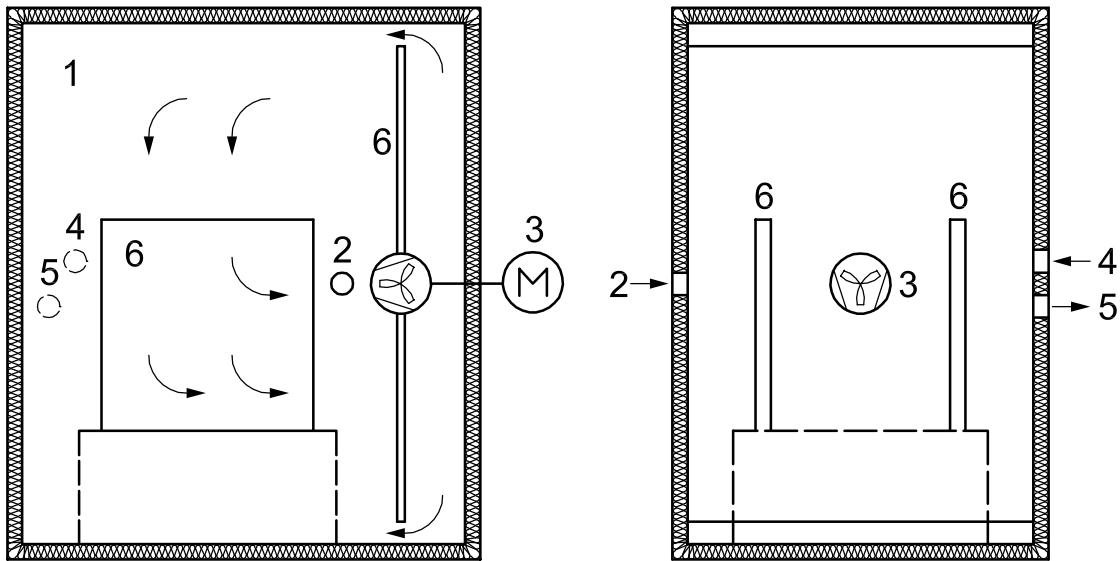

**Key**

- |   |  |   |  |
|---|--|---|--|
| 1 | 1 m <sup>3</sup> test chamber                | 4 | inlet for monitoring equipment/sensors |
| 2 | air inlet                                    | 5 | air outlet                             |
| 3 | ventilation fan with external electric power | 6 | test pieces                            |

**Figure 3 — Construction scheme for a 1 m<sup>3</sup> test chamber — Example 3**

Figure 4 shows an apparatus suitable to establish a relative humidity of (50 ± 3) %.

The volume of the inlet air is measured and adjusted by a gas pump or a compressed air system in connection with gas flow meters (see Figure 4) and can be measured by a calibrated gas meter in the outlet. The effective air exchange rate shall be regularly checked; see 8.3.4.

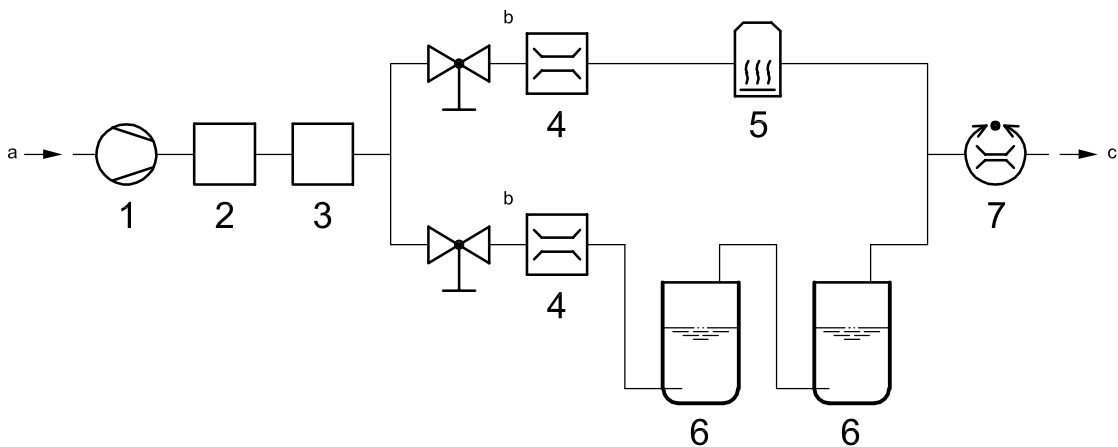

**Key**

- |   |  |   |   |
|---|--|---|---|
| 1 | gas pump                                     | 6 | washing bottle (humidification) with a minimum volume of 1 000 ml |
| 2 | activated alumina filter (optional, see 8.4) | 7 | flow controller or gas meter                                      |
| 3 | charcoal filter                              | a | Air (in).   |
| 4 | gas flow meter and gas flow control          | b | 50 % air flow.  |
| 5 | silica gel filter                            | c | To the chamber.   |

**Figure 4 — Example of a device for establishing a controlled air flow with a relative humidity of 50 %**

## 6.1.2 Construction principle

The test apparatus comprises the following components; see Figures 1, 2 and 3 (the numbers in brackets refer to the key items in Figures 1, 2 and 3):

**6.1.2.1 Chamber**, with a total volume of  $(1 \pm 0,01) \text{ m}^3$  (1).

NOTE The  $1 \text{ m}^3$  test chambers shown in the Figures 1, 2 and 3 as examples are constructed of metal, glass or plastic plates.

**6.1.2.2 Air inlet** (2); if necessary, the inlet air should be cleaned and preconditioned to near the test temperature.

NOTE The volume of the air flow through the test chamber is measured by a gas meter.

**6.1.2.3 Ventilation fan**, at least one (3).

NOTE The ventilation fan mixes the air in the chamber by intensive circulation.

**6.1.2.4 Inlet** (4), for the introduction of sensors for continuous or frequent monitoring of temperature and air relative humidity.

**6.1.2.5 Air outlet** (5).

**6.1.2.6 Baffle plates or partition or perforated bottom.**

**6.1.2.7 Test pieces.**

## 6.1.3 General

### 6.1.3.1 Test chamber materials

Materials used for the inner walls and ducts of test chambers shall have a smooth surface, which, prior to testing, can be effectively cleaned with water. The surface shall be as inert and non-absorptive as possible to formaldehyde.

Proven materials are stainless steel or aluminium (sandblasted or polished), glass and some types of plastics (PVC, PMMA). Plastic materials shall not be used if volatile organic compounds (VOCs) are to be tested together with formaldehyde.

### 6.1.3.2 Air-tightness of the chamber

The test chamber shall be air-tight in order to avoid uncontrolled air exchange. The criteria of air-tightness are given in 8.3.2.

### 6.1.3.3 Air circulation in the test chamber

The test chamber shall contain facilities (such as fan systems) capable of maintaining

- intensive air mixing in the chamber, and
- an air velocity of 0,1 m/s to 0,3 m/s at the surface of the test pieces (see 8.3.5).

### 6.1.3.4 Air exchange facilities

The test chamber shall contain air inlet and/or outlet facilities capable of regulating the air flow and thus the rate of air exchange (replacement of chamber air by clean, conditioned air) with an error limit of 5 % at an air exchange rate of 1/h.

Precautions shall be taken to ensure that the clean air inlet and the air circulation system are adequately placed to ensure sufficient mixing and that ambient air cannot enter into the air outlet, not even during sampling.

#### 6.1.3.5 Clean air supply of the test chamber

Equipment capable of providing clean air with a maximum formaldehyde content of 0,006 mg/m<sup>3</sup>.

#### 6.1.3.6 Temperature- and relative-humidity-regulating systems

Equipment capable of maintaining the temperature and the relative humidity in the test chamber within the following limits:

- temperature: (23 ± 0,5) °C;
- relative humidity: (50 ± 3) %.

NOTE Formaldehyde concentrations at 45 % relative humidity can be estimated from the values measured at 50 % relative humidity using the Andersen equation. For most materials, the concentration at 45 % relative humidity will be 5 % to 10 % lower.

#### 6.1.3.7 Equipment for monitoring of test conditions

Measuring equipment and recording facilities capable of continuous or frequent monitoring of the specified test conditions with an error limit as follows:

- temperature: 0,1 °C;
- relative humidity: 1 %;
- air exchange rate: 3 %;
- air velocity: 0,05 m/s.

## 6.2 Air sampling system

### 6.2.1 General

Figure 5 shows the principle of a sampling system for the determination of the formaldehyde concentration in the chamber air. The sampling tube shall be placed either in the air outlet, or inside the chamber, close to the air outlet.

Other sampling systems may be used, provided it can be shown that they give equivalent results.

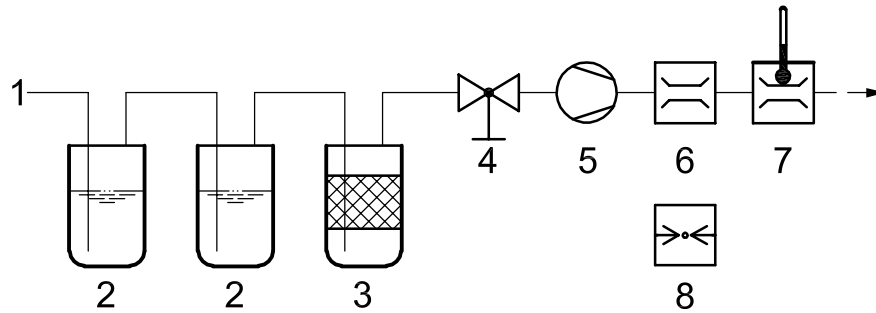

**Key**

- |   |                    |   |                            |
|---|--------------------|---|----------------------------|
| 1 | sampling tube      | 5 | gas sampling pump          |
| 2 | gas washing bottle | 6 | gas flow meter             |
| 3 | silica absorber    | 7 | gas meter with thermometer |
| 4 | gas flow valve     | 8 | air pressure meter         |

**Figure 5 — Example of a sampling system for the determination of formaldehyde concentration in air**

**6.2.2 Apparatus**

The air sampling system consists of the following components, which are shown in Figure 5. The numbers in brackets refer to the key items in Figure 5:

- 6.2.2.1 Gas washing bottles**, two, 100 ml, containing water, for absorption and subsequent determination of formaldehyde (2).
- 6.2.2.2 Silica absorber**, for drying of the air (3).
- 6.2.2.3 Gas flow valve** (4).
- 6.2.2.4 Gas sampling pump** (5).
- 6.2.2.5 Gas flow meter** (6).
- 6.2.2.6 Gas meter** (including a thermometer) for measuring the volume of air (7).
- 6.2.2.7 Air-pressure meter** (8).

**6.3 Equipment for chemical analysis**

- 6.3.1 Spectrophotometer**, suitable for use with cells with a path-length of at least 50 mm and capable of measuring absorbance at 412 nm.
- 6.3.2 Water bath**, capable of maintaining a temperature of  $(60 \pm 1) ^\circ\text{C}$ .
- 6.3.3 Volumetric flasks**, six, 100 ml (calibrated at  $20 ^\circ\text{C}$ ).
- 6.3.4 Volumetric flasks**, two, 1 000 ml (calibrated at  $20 ^\circ\text{C}$ ).
- 6.3.5 Bulb pipettes**, 5 ml, 10 ml, 15 ml, 20 ml, 25 ml, 50 ml and 100 ml (calibrated at  $20 ^\circ\text{C}$ ).
- 6.3.6 Micro burette**.
- 6.3.7 Flasks**, six, 50 ml, with stoppers.
- 6.3.8 Balance**, scale interval 0,001 g.

## 6.4 Equipment for verification of air exchange rate

### 6.4.1 Air meter.

## 6.5 Conditioning cabinet

Cabinet, capable of maintaining a relative humidity of  $(50 \pm 5) \%$ , a temperature of  $(23 \pm 1) ^\circ\text{C}$  and an air exchange rate of at least 1/h.

## 7 Test pieces

### 7.1 Sampling

Sampling and cutting of the test pieces shall be carried out in accordance with ISO 16999. If test pieces are not to commence the conditioning and testing procedure immediately, they may be wrapped in plastic and stored for a maximum time of 7 days.

### 7.2 Dimensions

The test pieces shall be  $(0,5 \pm 0,005)$  m in length and width.

### 7.3 Number of test pieces

The surface area of the test pieces shall be  $1 \text{ m}^2$ , usually two pieces of  $0,5 \text{ m} \times 0,5 \text{ m}$  are used.

### 7.4 Conditioning

The test pieces shall be conditioned for  $(15 \pm 2)$  days in an atmosphere with a relative humidity of  $(50 \pm 5) \%$  and a temperature of  $(23 \pm 1) ^\circ\text{C}$ . The test pieces to be conditioned shall be separated by at least 25 mm and positioned so that free circulation of air occurs over all surfaces. The air in the conditioning cabinet shall be exchanged at least 1/h. The formaldehyde concentration of the air in the conditioning cabinet shall not exceed  $0,10 \text{ mg/m}^3$ , when measured in accordance with Clause 9.

NOTE A cabinet with less ventilation can also be used if an air purification system is used to maintain the background concentration  $< 0,10 \text{ mg/m}^3$ .

### 7.5 Sealing of test pieces edges

After conditioning, test piece edges shall be partly sealed using self adhesive aluminium tape to give a constant ratio of the length,  $l$ , of the open (unsealed) edges to the surface area,  $A$ , so that  $l/A = 1,5 \text{ m/m}^2$ . For the dimensions specified in 7.2, each test piece shall have 1,25 m of the edges sealed and 0,75 m of the edges unsealed.

NOTE As a result of the constant ratio  $l/A = 1,5 \text{ m/m}^2$ , the percentage of open edges area related to the surface area depends on the thickness of the test piece, as shown in the following examples:

Panel thickness	Percentage of open edges area
10 mm	1,5 %
19 mm	2,8 %
32 mm	4,8 %

Flooring material shall be tested with the face exposed only. This can be achieved either by gluing two pieces back-to-back or by sealing the back of the test piece with aluminium tape. In both cases, all edges should also be sealed with aluminium tape.

## 8 Procedure

### 8.1 General

Prior to loading test pieces, the correct test conditions should be established and the “background level” formaldehyde concentration measured in the empty chamber.

### 8.2 Test conditions

The following conditions shall be maintained in the chamber throughout the test:

- temperature:  $(23 \pm 0,5) ^\circ\text{C}$ ;
- relative humidity:  $(50 \pm 3) \%$ ;
- loading factor:  $(1,0 \pm 0,02) \text{ m}^2/\text{m}^3$ ;
- air exchange rate:  $(1,0 \pm 0,05)/\text{h}$ ;
- air velocity at the surface of the test pieces (see 8.3.5):  $(0,1 \text{ to } 0,3) \text{ m/s}$ .

### 8.3 Verification of test conditions

#### 8.3.1 Clean air supply of the test chamber

When determined in accordance with Clause 9, the formaldehyde content of the air supplied to the chamber shall not exceed  $0,006 \text{ mg}/\text{m}^3$ .

#### 8.3.2 Air-tightness of the test chamber

In order to avoid uncontrolled air exchange by intrusion of ambient air, the test chamber shall be operated at a slight over-pressure.

Air-tightness shall be checked regularly, either by pressure-drop measurements or by comparison of simultaneous measurement of flow rates at the inlet and the outlet ports, or by measuring tracer gas dilution.

The test chamber is considered sufficiently air-tight if at least one of the following requirements is fulfilled.

- The air leakage is less than  $10^{-2}$  times the chamber volume per minute at an overpressure of 1 000 Pa.
- The inlet and outlet air flow differ by less than 10 %.
- The recovery in the chamber is  $> 90 \%$ .

NOTE This can be tested by putting a vial containing formaldehyde in the chamber, see Reference [9].

#### 8.3.3 Temperature and relative humidity control system

Control of temperature shall be made either by placing the test chamber within a location controlled to the appropriate temperature, or by controlling the temperature within the chamber.

In the latter case, the chamber walls shall be insulated effectively to avoid condensation of moisture on their inner surface.

Control of relative humidity shall be made either by external humidity control of the clean air supply, or internal humidity control of the air within the chamber. In the latter case, precautions shall be taken to avoid condensation, or spray of water, inside the chamber.



Temperature and relative humidity shall be monitored either continuously, or frequently, and independently of the air conditioning system. Sensors shall be placed in a representative position inside the chamber.

After loading the chamber, any initial deviations of temperature and relative humidity due to ambient air and unconditioned test pieces shall be recorded.

#### 8.3.4 Air exchange

The effective air exchange rate shall be regularly checked by using a calibrated gas meter.

#### 8.3.5 Air velocity in the chamber

Prior to testing, the air velocity in the test chamber loaded with test pieces shall be set to a value of 0,1 m/s to 0,3 m/s, measured at representative positions not more than 20 mm from the surface of the test pieces.

Hot-wire or film anemometers calibrated in the range of 0 m/s to 0,5 m/s are suitable for air velocity measurement. Air velocity should be measured at a minimum of two positions in the chamber.

### 8.4 Chamber preparation

Set the chamber to the conditions given in 8.2. The determination (see 8.6) of the formaldehyde concentration in the empty chamber ("background-level") shall be carried out not less than 1 h after establishing the test conditions according to 8.2.

If the formaldehyde concentration in the chamber atmosphere is 0,006 mg/m<sup>3</sup> or lower, the chamber can be loaded with the test pieces.

If the formaldehyde concentration is higher than 0,006 mg/m<sup>3</sup>, the following possibilities should be considered.

- Install an activated alumina filter to remove formaldehyde from inlet air.
- Clean all interior surfaces of the chamber, followed by purging by running the chamber empty.

### 8.5 Loading and starting procedure

Within 1 h of the test pieces completing conditioning, place them in the test chamber. They shall be vertical and approximately near to the centre of the chamber, with their surfaces parallel to the direction of the air flow, and separated by not less than 200 mm; see Figures 1, 2 and 3.

### 8.6 Air sampling and analysis

Add at least 25 ml of water to each of the two gas washing bottles and connect it to the apparatus; see 6.2 and Figure 5). Sample the air from the chamber periodically by passing a minimum of 120 l, at a rate of approximately 2 l/min, through the gas washing bottle. The mass of the absorption solution has to be determined after each sampling. If the mass lost is higher than 3 % this shall be corrected for. Mix the contents of the two gas washing bottles together and then pipette 10 ml of each of the absorption solutions into a 50 ml flask and add 10 ml acetylacetone solution (see 5.1) and 10 ml of ammonium acetate solution (see 5.2). Stopper the flasks and determine the formaldehyde content of the solutions according to Clause 9.

The volume of air to be sampled depends on its formaldehyde concentration. With photometric determination, the procedure described above is suitable for concentrations higher than 0,005 mg/m<sup>3</sup>. For determination of lower concentrations, the volume of the sampled air volume should be increased and/or the volume of the air sample solution reduced. The sensitivity of the analysis can also be increased by using a fluorimetric determination of the reaction product (diacetyldihydrolutidine) instead of a photometric determination. Furthermore, the mass loss of the absorption solution should be determined by weighing and a sufficient water level above the gas wash bottle inserts should be ensured.

### 8.7 Test duration

On the first day of the test, no sampling is required; then for days 2 to 5, sampling is conducted twice per day. The time interval between the two samplings should be greater than 3 h.

The sampling can be stopped any time after the first three days if steady state is reached. For this purpose, steady state is defined as when the deviation of the mean value of the last four measured formaldehyde concentrations and the highest or lowest measurement during that time is below 5 % or 0,005 mg/m<sup>3</sup>, i.e.:

- Mean value:  $v = (B_n + B_{n-1} + B_{n-2} + B_{n-3})/4$
- Deviation:  $d = \text{abs. maximum} [(v - B_n), (v - B_{n-1}), (v - B_{n-2}), (v - B_{n-3})]$
- Steady-state condition when:  $d \times 100/v < 5 \%$ , or  $d < 0,005 \text{ mg/m}^3$ .

where

$B_n$  is the last concentration measurement;

$B_{n-1}$  is second last concentration measurement, etc.

Sampling may be omitted on certain days (e.g. weekends), but the steady-state determination shall be extended back to include the last four measurements.

If no steady state is reached during the first five days, sampling is reduced to once per day until steady state is achieved or the test has continued for 28 days, then the test is stopped.

## 9 Determination of formaldehyde emission

### 9.1 General

The formaldehyde content of the aqueous solutions from each sampling period shall be determined photometrically by the acetyl acetone method. The method should be able to provide a determination limit of 0,005 mg/m<sup>3</sup>.

NOTE To enhance the sensitivity of the analysis, the formaldehyde content can also be determined fluorimetrically (see Annex A) or using the 2,4-DNPH method according to ISO 16000-3. These techniques can be necessary if low-emitting materials are tested.

### 9.2 Principle

The determination is based on the Hantzsch reaction in which formaldehyde reacts with ammonium ions and acetylacetone to yield diacetyldihydrolutidine (DDL); see Figure 6. DDL has an absorption maximum at 412 nm. The reaction is specific to formaldehyde; see Reference [11].

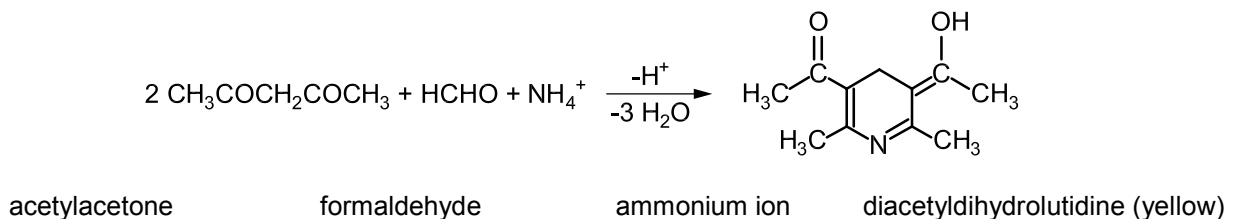

Figure 6 — Reaction scheme of the acetylacetone method

### 9.3 Procedure

Heat the stoppered flask (see 8.6) for 10 min in a water bath at  $(60 \pm 1) ^\circ\text{C}$ . The solution is then stored at room temperature for about 1 h, protected against the influence of light. The absorbance of the solution is determined at a wavelength of 412 nm against water, using a spectrophotometer with a cell of 50 mm path-length (see 6.3.1).

Cells with greater path-length can be used, but these give different calibration curves and, in this case, a modified evaluation procedure is necessary. Cells with 10 mm path length may be used as long as the lower limit of  $0,005 \text{ mg/m}^3$  can be reached.

A blank value is determined in parallel, using a solution made up of 10 ml water, 10 ml acetylacetone solution (see 5.1) and 10 ml ammonium acetate solution (see 5.2) and is taken into consideration when calculating the formaldehyde content of the sample solution.

### 9.4 Calibration curve

#### 9.4.1 General

The calibration curve (see Figure 7) is produced from a standard formaldehyde solution, the concentration of which has been determined by iodometric titration. This calibration curve shall be checked at least once a month.

Other analytical procedures may be used to determine the concentration of formaldehyde in the standard formaldehyde solution provided such methods give results comparable to those obtained by using the iodometric titration method. For other analytical procedures to be employed, the test results and test report shall be properly qualified and the analytical procedure used shall be accurately described.

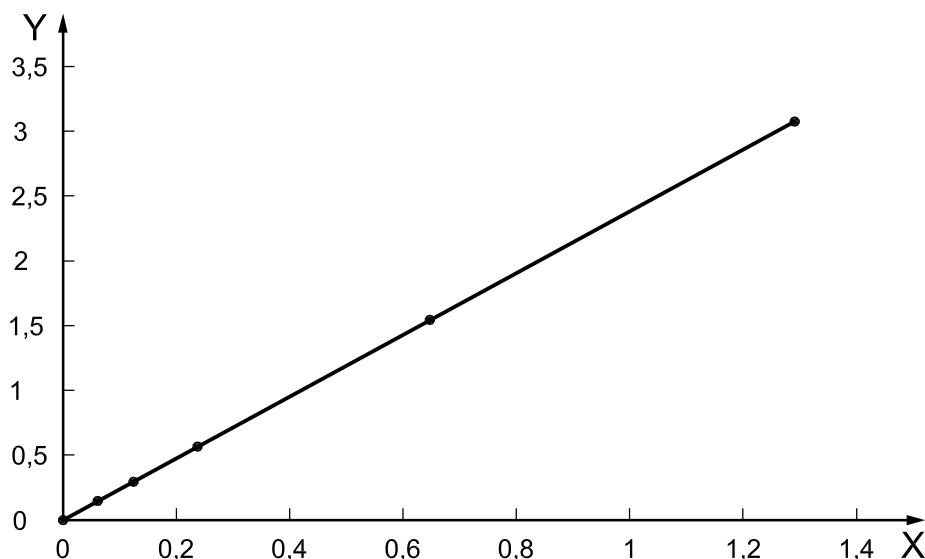

$$C = f \cdot (\alpha_s - \alpha_b)$$

#### Key

X absorbance,  $\alpha_s - \alpha_b$

Y concentration,  $C$ ,  $\times 10^{-3} \text{ mg/ml}$ , of the diluted calibration solution

**Figure 7 — Example of a calibration curve for formaldehyde determined by acetylacetone method (path length 50 mm)**

### 9.4.2 Formaldehyde standard solution

Reagents:

- standard iodine solution,  $c(I_2) = 0,05 \text{ mol/l}$ ;
- standard sodium thiosulfate solution,  $c(\text{Na}_2\text{S}_2\text{O}_3) = 0,1 \text{ mol/l}$ ;
- standard sodium hydroxide solution,  $c(\text{NaOH}) = 1 \text{ mol/l}$ ;
- standard sulfuric acid solution,  $c(\text{H}_2\text{SO}_4) = 1 \text{ mol/l}$ ;

The above solutions shall be standardized before use.

- starch solution, 1 % by mass

Dilute about 1 g formaldehyde solution (concentration 35 % to 40 %) in a 1 000 ml volumetric flask with water and make up to the mark. Determine the exact formaldehyde concentration as follows:

Mix 20 ml of the formaldehyde standard solution with 25 ml iodine solution and 10 ml sodium hydroxide solution. After 15 min standing protected from light add 15 ml of sulfuric acid solution. Titrate back the excess iodine with the sodium thiosulfate solution. Near the end of the titration, add some drops of the starch solution as an indicator. Carry out in parallel a blank test with 20 ml of water.

The formaldehyde concentration,  $C_{\text{HCHO}}$ , expressed in milligrams per litre, is calculated as given in Equation (1):

$$C_{\text{HCHO}} = (V_0 - V) \times 15 \times c(\text{Na}_2\text{S}_2\text{O}_3) \times 1\,000/20 \quad (1)$$

where

$V$  is the volume of the consumed thiosulfate titration solution, expressed in millilitres;

$V_0$  is the volume of the consumed thiosulfate titration solution for blank, expressed in millilitres;

$c(\text{Na}_2\text{S}_2\text{O}_3)$  is the thiosulfate concentration, expressed in moles per litre.

NOTE 1 ml of 0,1 mol/l thiosulfate corresponds to 1 ml of 0,05 mol/l iodine solution and 1,5 mg formaldehyde.

### 9.4.3 Formaldehyde calibration solution

Using the concentration value determined in 9.4.2, calculate the volume of the formaldehyde solution that contains 3 mg formaldehyde. Transfer this volume, using a microburette, to a 1 000 ml volumetric flask and make up to the mark with water. 1 ml of this calibration solution contains 3 µg formaldehyde.

### 9.4.4 Determination of the calibration curve

Pipette either 0 ml, 5 ml, 10 ml, 20 ml, 50 ml or 100 ml of the formaldehyde calibration solution (see 9.4.3) into a 100 ml volumetric flask and make up to the mark with water. 10 ml of each dilution are analysed photometrically by the same procedure as described in 9.3. The absorbance values are plotted against the formaldehyde concentrations,  $C_{\text{HCHO}}$ , (between 0 mg/ml and 0,003 mg/ml, see example in Figure 7). The slope,  $f$ , of the graph is either determined graphically or calculated.

### 9.5 Calculation of the amount of formaldehyde trapped in the gas washing bottle

The mass,  $m$ , expressed in milligrams, of formaldehyde in the air drawn through the gas washing bottle is calculated as given in Equation (2):

$$m = (\alpha_s - \alpha_b) \cdot f \cdot V_{\text{sol}} \quad (2)$$

where

$\alpha_s$  is the absorbance of the solution from the gas washing bottle;

$\alpha_b$  is the absorbance of the blank (see 9.3);

$f$  is the slope of the calibration curve for the standard formaldehyde solution, expressed in milligrams per millilitre;

$V_{\text{sol}}$  is the volume of the trapping solution, expressed in millilitres;

### 9.6 Calculation of the formaldehyde emission

The formaldehyde emission,  $B$ , expressed in milligrams per cubic metre, from the wood-based panels being tested is expressed as the concentration in the air of the test chamber and is calculated as given in Equation (3):

$$B = m/V_{\text{air}} \quad (3)$$

where

$m$  is the mass of formaldehyde trapped, expressed in milligrams;

$V_{\text{air}}$  is the volume of the air sample, expressed in cubic metres.

The volume of the sampled air should be corrected to a standard temperature of 23 °C (296 K) and a standard air pressure of 1 013 hPa.

The sampling and calculation procedure shall consider the principles of ISO 16000-3.

## 10 Determination of steady-state emission value

When steady state is achieved (see 8.7), the formaldehyde emission value is the mean of the last four concentration measurements.

If steady state is not reached within 28 days of testing, a formaldehyde emission value cannot be reported. In this case, the average of the final four concentration measurements should be reported as an "interim formaldehyde emission value", followed by the statement "steady state not reached".

## 11 Expression of results

The steady-state emission value is expressed in milligrams per cubic metre rounded to the next 0,01 mg/m<sup>3</sup>. The test duration (in hours) to establish the steady-state emission value shall be indicated in brackets after the value.

## 12 Test report

The test report shall be in accordance with ISO 16999. Additionally, the test report shall include the following information:

- a) type of the chamber (option);
- b) if appropriate and known, the name of the producer, the date and place of production, as well as the manner of shipment, the handling between arrival at the test laboratory and the start of the test;
- c) date of starting and ending of the preconditioning procedure;
- d) date of starting and ending of the test procedure;
- e) short description of the test conditions and the analytical procedure used;
- f) steady-state emission value, expressed in milligrams formaldehyde per cubic meter;
- g) number of hours required to achieve the steady-state emission value;
- h) description of further items (e.g. report on procedures that are not in accordance with this part of ISO 12460).

## Annex A (informative)

### Analytical procedure for the fluorimetric determination of formaldehyde content

#### A.1 Reagents

Reagents and water of recognized analytical purity shall be used for the analysis.

##### A.1.1 Acetylacetone solution.

4 ml acetyl acetone are added to a 1 000 ml volumetric flask and made up to the mark with water.

##### A.1.2 Ammonium acetate solution.

200 g ammonium acetate are dissolved in water in a 1 000 ml volumetric flask and made up to the mark.

Commercially prepared solutions may be used.

#### A.2 Air sampling and analysis

Add 25 ml water to each of the two gas washing bottles. Sample the air from the chamber by passing a minimum of 30 l, at a rate of approximately 1,5 l/min to 2,0 l/min through the gas washing bottles. Mix the contents of the two gas washing bottles together and then pipette 10 ml of each of the absorption solutions into a 50 ml flask and add 10 ml acetylacetone solution (see A.1.1) and 10 ml of ammonium acetate solution (see A.1.2).

Heat the stoppered flasks for 15 min in a water bath at  $(40 \pm 1) ^\circ\text{C}$ . The solutions are then stored at room temperature for 1 h, protected against the influence of light. A blank value is determined in parallel, using a solution made up of 10 ml water, 10 ml acetylacetone solution and 10 ml ammonium acetate solution and is taken into consideration when calculating the formaldehyde content of the sample solution.

#### A.3 Equipment for chemical analysis

##### A.3.1 Fluorimetric spectrophotometer.

##### A.3.2 Water bath, capable of maintaining a temperature of $(40 \pm 1) ^\circ\text{C}$ .

##### A.3.3 Volumetric flasks, 1 000 ml (calibrated at $20 ^\circ\text{C}$ ).

##### A.3.4 Pipettes, 1 ml, 3 ml, 5 ml, 10 ml, 20 ml and 50 ml (calibrated at $20 ^\circ\text{C}$ ).

##### A.3.5 Volumetric flasks, 100 ml (calibrated at $20 ^\circ\text{C}$ ).

##### A.3.6 Flasks, with stoppers (50 ml).

##### A.3.7 Balance, scale interval 0,1 mg.

## A.4 Calibration curve

### A.4.1 General

The calibration curve is produced from a formaldehyde solution, the concentration of which has been determined by iodometric titration. This calibration curve is checked at least once a week.

### A.4.2 Formaldehyde standard solution

A formaldehyde solution is made containing by adding 1,000 g formaldehyde in water to a 1 000 ml volumetric flask and making up to the mark with water. 1 ml of this solution contains 1 mg formaldehyde.

### A.4.3 Formaldehyde calibration solution

Transfer 1 ml of the formaldehyde standard solution to a 1 000 ml volumetric flask and make up to the mark with water. 1 ml of this calibration solution contains 1 µg formaldehyde.

### A.4.4 Determination of the calibration curve

Pipette either 1 ml, 3 ml, 5 ml, 10 ml, 20 ml or 50 ml of the formaldehyde calibration solution (see A.4.3) into a 100 ml volumetric flask and made up to the mark with water.

10 ml of each are added to a 50 ml flask to which is added 10 ml acetylacetone solution (see A.1.1) and 10 ml of ammonium acetate solution (see A.1.2). Heat the stoppered flasks for 15 min in a water bath at  $(65 \pm 2) ^\circ\text{C}$ . The solutions are then stored at room temperature for 1 h, protected against the influence of light. The fluorescence intensity is determined at a wavelength of excitation  $\lambda_{\text{ex}} = 410 \text{ nm}$  and a wavelength of emission  $\lambda_{\text{em}} = 510 \text{ nm}$ . The intensity values are plotted against the formaldehyde concentrations between 0 µg/ml and 1 µg/ml. The slope of the graph is either determined graphically or calculated.

## A.5 Calculation of the amount of absorbed formaldehyde and calculation of the formaldehyde emission

See 9.5 and 9.6.



## Bibliography

- [1] CEC Project: *Investigation an comparability of large chamber test for formaldehyde emission from wood based panels, Part 1: Main programme*, Wilhelm-Klauditz-Institute, Braunschweig, November 1992
- [2] CEC Project: *Investigation an comparability of large chamber test for formaldehyde emission from wood based panels, Part II: Accompanying programme*, Wilhelm-Klauditz-Institute, Braunschweig, December 1993
- [3] HOETJER, J.J. and KOERTS, F. *A Model for Formaldehyde Release from Wood Products*, in: CEN Report CR 213
- [4] COLOMBO, A., JANN, O. and MARUTZKY, R. The estimation of the steady state formaldehyde-concentration in large chambers, *Staub-Reinhaltung der Luft*, **54** (1994), pp. 143-146
- [5] COST Project 613: *Indoor Air Quality and its Impact an Man. Report No. 2: Formaldehyde emission from wood based materials: Guideline for the determination of steady state concentrations in test chambers*
- [6] COST Project 613: *Indoor Air Quality and its Impact an Man. Report No. 8: Guideline for the characterisation of volatile organic compounds emitted from indoor materials and products, using small test chambers*
- [7] ASTM E1333-96 (2002), *Standard Test Method for Determining Formaldehyde Concentration in Air and Emission Rates from Wood Products Using a Large Chamber*
- [8] Swedish Standard SS 270236, *Building boards — Determination of formaldehyde emission*
- [9] *Indoor Air*, 1999:9, pp. 268-272
- [10] ANDERSEN, I., LUNDQUIST, G.R. and MOLHAVE, L. Liberation of formaldehyde from particleboard. A mathematical model, *Ugesr. Laeg.*, **136** (174), pp. 2145-2150
- [11] BELMAN, S. The fluorimetric determination of formaldehyde, *Analytica Chimica Acta*, **29** (1963), pp. 120-126
- [12] EN 120, *Wood based panels — Determination of formaldehyde content — Extraction method called the perforator method*
- [13] ISO 12460-2, *Wood-based panels — Determination of formaldehyde release — Part 2: Small-scale chamber method*
- [14] ISO 12460-3, *Wood-based panels — Determination of formaldehyde release — Part 3: Gas analysis method*
- [15] ISO 12460-4, *Wood-based panels — Determination of formaldehyde release — Part 4: Desiccator method*
- [16] ASTM D6007, *Standard Test Method for Determining Formaldehyde Concentration in Air from Wood Products Using a Small Scale Chamber*

---

---

**ICS 79.060.01**

Price based on 19 pages