

---

---

**Electrically propelled road vehicles —  
Test specification for lithium-ion traction  
battery packs and systems —**

**Part 1:  
High-power applications**

*Véhicules routiers à propulsion électrique — Spécifications d'essai pour  
packs et systèmes de batterie de traction aux ions lithium —*

*Partie 1: Applications à haute puissance*



Reference number  
ISO 12405-1:2011(E)

© ISO 2011



**COPYRIGHT PROTECTED DOCUMENT**

© ISO 2011

All rights reserved. Unless otherwise specified, no part of this publication may be reproduced or utilized in any form or by any means, electronic or mechanical, including photocopying and microfilm, without permission in writing from either ISO at the address below or ISO's member body in the country of the requester.

ISO copyright office  
Case postale 56 • CH-1211 Geneva 20  
Tel. + 41 22 749 01 11  
Fax + 41 22 749 09 47  
E-mail [copyright@iso.org](mailto:copyright@iso.org)  
Web [www.iso.org](http://www.iso.org)

Published in Switzerland

# Contents

Page

Foreword .....	iv
Introduction.....	v
<b>1 Scope .....</b>	<b>1</b>
<b>2 Normative references .....</b>	<b>1</b>
<b>3 Terms and definitions .....</b>	<b>2</b>
<b>4 Symbols and abbreviated terms .....</b>	<b>4</b>
<b>4.1 Symbols.....</b>	<b>4</b>
<b>4.2 Abbreviated terms .....</b>	<b>5</b>
<b>5 General requirements .....</b>	<b>5</b>
<b>5.1 General conditions .....</b>	<b>5</b>
<b>5.2 Test sequence plan .....</b>	<b>6</b>
<b>5.3 Tests .....</b>	<b>6</b>
<b>5.4 Battery pack — Typical configuration.....</b>	<b>8</b>
<b>5.5 Battery system — Typical configuration.....</b>	<b>8</b>
<b>5.6 Preparation of battery pack and system for bench testing.....</b>	<b>11</b>
<b>6 General tests .....</b>	<b>11</b>
<b>6.1 Preconditioning cycles .....</b>	<b>11</b>
<b>6.2 Standard cycle.....</b>	<b>12</b>
<b>7 Performance tests .....</b>	<b>12</b>
<b>7.1 Energy and capacity at room temperature .....</b>	<b>12</b>
<b>7.2 Energy and capacity at different temperatures and discharge rates.....</b>	<b>14</b>
<b>7.3 Power and internal resistance .....</b>	<b>17</b>
<b>7.4 No-load SOC loss .....</b>	<b>22</b>
<b>7.5 SOC loss at storage .....</b>	<b>24</b>
<b>7.6 Cranking power at low temperature .....</b>	<b>26</b>
<b>7.7 Cranking power at high temperature.....</b>	<b>27</b>
<b>7.8 Energy efficiency.....</b>	<b>29</b>
<b>7.9 Cycle life .....</b>	<b>31</b>
<b>8 Reliability tests .....</b>	<b>38</b>
<b>8.1 Dewing — Temperature change.....</b>	<b>38</b>
<b>8.2 Thermal shock cycling.....</b>	<b>40</b>
<b>8.3 Vibration .....</b>	<b>40</b>
<b>8.4 Mechanical shock.....</b>	<b>45</b>
<b>9 Abuse tests .....</b>	<b>46</b>
<b>9.1 Information .....</b>	<b>46</b>
<b>9.2 Short-circuit protection.....</b>	<b>46</b>
<b>9.3 Overcharge protection .....</b>	<b>47</b>
<b>9.4 Overdischarge protection.....</b>	<b>48</b>
<b>Annex A (informative) Battery pack and system and overview on tests .....</b>	<b>49</b>
<b>Annex B (informative) Examples of data sheet for battery pack and system testing.....</b>	<b>53</b>
<b>Annex C (informative) Example of test conditions .....</b>	<b>57</b>
<b>Bibliography.....</b>	<b>58</b>

## Foreword

ISO (the International Organization for Standardization) is a worldwide federation of national standards bodies (ISO member bodies). The work of preparing International Standards is normally carried out through ISO technical committees. Each member body interested in a subject for which a technical committee has been established has the right to be represented on that committee. International organizations, governmental and non-governmental, in liaison with ISO, also take part in the work. ISO collaborates closely with the International Electrotechnical Commission (IEC) on all matters of electrotechnical standardization.

International Standards are drafted in accordance with the rules given in the ISO/IEC Directives, Part 2.

The main task of technical committees is to prepare International Standards. Draft International Standards adopted by the technical committees are circulated to the member bodies for voting. Publication as an International Standard requires approval by at least 75 % of the member bodies casting a vote.

Attention is drawn to the possibility that some of the elements of this document may be the subject of patent rights. ISO shall not be held responsible for identifying any or all such patent rights.

ISO 12405-1 was prepared by Technical Committee ISO/TC 22, *Road vehicles*, Subcommittee SC 21, *Electrically propelled road vehicles*.

ISO 12405 consists of the following parts, under the general title *Electrically propelled road vehicles — Test specification for lithium-ion traction battery systems*:

- *Part 1: High-power applications*
- *Part 2: High-energy applications*

## Introduction

Lithium-ion-based battery systems are an efficient alternative energy storage system for electrically propelled vehicles. The requirements for lithium-ion based battery systems for use as a power source for the propulsion of electric road vehicles are significantly different from those batteries used for consumer electronics or stationary usage.

This part of ISO 12405 provides specific test procedures for lithium-ion battery packs and systems specially developed for propulsion of road vehicles. This part of ISO 12405 specifies such tests and related requirements to ensure that a battery pack or system is able to meet the specific needs of the automobile industry. It enables vehicle manufactures to choose test procedures to evaluate the characteristics of a battery pack or system for their specific requirements.

A coordination of test specifications for battery cells, packs and systems for automotive application is necessary for the practical usage of standards.

For specifications for battery cells, see IEC 62660-1 and IEC 62660-2.

Some tests as prescribed within this specification are based on existing specifications, i.e. *USABC*, *EUCAR*, *FreedomCAR* and other sources.

.....

# Electrically propelled road vehicles — Test specification for lithium-ion traction battery packs and systems —

## Part 1: High-power applications

### 1 Scope

This part of ISO 12405 specifies test procedures for lithium-ion battery packs and systems for use in electrically propelled road vehicles.

The specified test procedures enable the determination of the essential characteristics of performance, reliability and abuse of lithium-ion battery packs and systems. They assist the user of this part of ISO 12405 to compare the test results achieved for different battery packs or systems.

Therefore, this part of ISO 12405 specifies standard test procedures for basic characteristics of performance, reliability and abuse of lithium-ion battery packs and systems.

This part of ISO 12405 enables the setting up of a dedicated test plan for an individual battery pack or system subject to agreement between the customer and supplier. If required, the relevant test procedures and/or test conditions of lithium-ion battery packs and systems can be selected from the standard tests provided in this part of ISO 12405 to configure a dedicated test plan.

This part of ISO 12405 specifies tests for high-power battery packs and systems.

NOTE 1 Typical applications for high-power battery packs and systems are hybrid electric vehicles (HEVs) and fuel cell vehicles (FCVs).

NOTE 2 Testing on cell level is specified in IEC 62660-1 and IEC 62660-2.

### 2 Normative references

The following referenced documents are indispensable for the application of this document. For dated references, only the edition cited applies. For undated references, the latest edition of the referenced document (including any amendments) applies.

ISO 6469-1, *Electrically propelled road vehicles — Safety specifications — Part 1: On-board rechargeable energy storage system (RESS)*

ISO 6469-3, *Electrically propelled road vehicles — Safety specifications — Part 3: Protection of persons against electric shock*

ISO 16750-1, *Road vehicles — Environmental conditions and testing for electrical and electronic equipment — Part 1: General*

ISO 16750-3, *Road vehicles — Environmental conditions and testing for electrical and electronic equipment — Part 3: Mechanical loads*

ISO 16750-4: *Road vehicles — Environmental conditions and testing for electrical and electronic equipment — Part 4: Climatic loads*

IEC 60068-2-30, *Environmental testing — Part 2-30: Tests — Test Db: Damp heat, cyclic (12 h + 12 h cycle)*

IEC 60068-2-47 *Environmental testing — Part 2-47: Test — Mounting of specimens for vibration, impact and similar dynamic tests*

IEC 60068-2-64:2008, *Environmental testing — Part 2-64: Tests — Test Fh: Vibration, broadband random and guidance*

### 3 Terms and definitions

For the purposes of this document, the following terms and definitions apply.

#### 3.1

##### **battery control unit**

##### **BCU**

electronic device that controls, manages, detects or calculates electric and thermal functions of the battery system and that provides communication between the battery system and other vehicle controllers

NOTE See 5.5.1 for further explanation.

#### 3.2

##### **battery pack**

energy storage device that includes cells or cell assemblies normally connected with cell electronics, voltage class B circuit and overcurrent shut-off device, including electrical interconnections, interfaces for external systems

NOTE 1 For further explanation, see 5.4 and A.2.

NOTE 2 Examples of external systems are cooling, voltage class B, auxiliary voltage class A and communication.

#### 3.3

##### **battery system**

energy storage device that includes cells or cell assemblies or battery pack(s) as well as electrical circuits and electronics

NOTE 1 For further explanation, see 5.5.2, 5.5.3, A.3.1 and A.3.2. Battery system components can also be distributed in different devices within the vehicle.

NOTE 2 Examples of electronics are the BCU and contactors.

#### 3.4

##### **capacity**

*C*  
electrical charge that can be delivered from a battery pack or system under specified conditions

NOTE The capacity is often expressed in ampere-hours (A·h), where 1 A·h = 3 600 *C*.

#### 3.5

##### **cell electronics**

electronic device that collects and possibly monitors thermal and electric data of cells or cell assemblies and contains electronics for cell balancing, if necessary

NOTE The cell electronics may include a cell controller. The functionality of cell balancing may be controlled by the cell electronics or by the BCU.



**3.6****customer**

party that is interested in using the battery pack or system and, therefore, orders or performs the test

EXAMPLE A vehicle manufacturer.

**3.7****energy density**

amount of stored energy related to the battery pack or system volume

NOTE 1 The battery pack or system includes the cooling system, if any, to the point of a reversible attachment of the coolant lines or air ducts, respectively.

NOTE 2 Energy density is expressed in watt hours per litre (W·h/l).

**3.8****energy round-trip efficiency**

ratio of the net d.c. energy delivered by a DUT during a discharge test to the total d.c. energy required to restore the initial SOC by a standard charge

NOTE The net d.c. energy is expressed as watt hours (W·h) discharge and the total d.c. energy is expressed as watt hours (W·h) charge.

**3.9****high-energy application**

characteristic of device or application, for which the numerical ratio between maximum allowed electric power output and electric energy output at a 1 C discharge rate at room temperature for a battery pack or system is typically lower than 10

NOTE 1 Typically high-energy battery packs and systems are designs for applications in BEVs.

NOTE 2 The allowed electric power output is expressed as power in watts (W) and the electric energy output is expressed as energy in watt hours (W·h).

**3.10****high-power application**

characteristic of device or application, for which the numerical ratio between maximum allowed electric power output and electric energy output at a 1 C discharge rate at room temperature for a battery pack or system is typically equal to or higher than 10

NOTE 1 Typically high-power battery packs and systems are designs for applications in HEVs and FCVs.

NOTE 2 The allowed electric power output is expressed as power in watts (W) and the electric energy output is expressed as energy in watt hours (W·h).

**3.11****maximum working voltage**

highest value of a.c. voltage (r.m.s) or of d.c. voltage which may occur in an electrical system under any normal operating conditions according to the manufacturer's specifications, disregarding transients

**3.12****rated capacity**

supplier's specification of the total number of ampere hours that can be withdrawn from a fully charged battery pack or system for a specified set of test conditions, such as discharge rate, temperature and discharge cut-off voltage

**3.13****room temperature**

$T_{\text{room}}$

temperature of  $(25 \pm 2) \text{ }^\circ\text{C}$

**3.14**

**sign of battery current**

discharge current is specified as positive and the charge current as negative

**3.15**

**specific energy**

amount of stored energy related to the battery pack or system mass

NOTE 1 The battery pack or system includes the cooling system, if any, to the point of a reversible attachment of the coolant lines or air ducts, respectively. For liquid-cooled systems, the coolant mass inside the battery pack or system is included.

NOTE 2 Specific energy is expressed in watt hours per kilogram (W·h/kg).

**3.16**

**state of charge**

**SOC**

available capacity in a battery pack or system

NOTE State of charge is expressed as a percentage of rated capacity.

**3.17**

**supplier**

party that provides battery systems and packs

EXAMPLE A battery manufacturer.

**3.18**

**voltage class A**

classification of an electric component or circuit with a maximum working voltage of  $\leq 30$  V a.c. or  $\leq 60$  V d.c., respectively

NOTE For more details, see ISO 6469-3.

**3.19**

**voltage class B**

classification of an electric component or circuit with a maximum working voltage of ( $> 30$  and  $\leq 1000$ ) V a.c. or ( $> 60$  and  $\leq 1500$ ) V d.c., respectively

NOTE For more details, see ISO 6469-3.

**4 Symbols and abbreviated terms**

**4.1 Symbols**

Symbol	Description	Unit
$C_{fade}$	Capacity fade	percentage
$C_{rttx}$	1 C (rated) capacity at current test	A·h
$C_{rtt0}$	Rated 1 C capacity at BOL	A·h
$I_{charge}$	Charge current	A
$I_{discharge}$	Discharge current	A
$I_{d,max}$	Maximum discharge current, specified by the manufacturer for energy and capacity testing	A
$I_{dp,max}$	Maximum discharge pulse current, specified by the manufacturer for power, internal resistance and energy efficiency testing	A

$T_{\max}$	Maximum operating temperature	°C
$T_{\min}$	Minimum operating temperature	°C
$T_{\text{room}}$	Room temperature	°C
$t$	Time	s
$\eta$	Efficiency	%

## 4.2 Abbreviated terms

BOL	Beginning of life
DUT	Device under test
EODV	End of discharge voltage
EUCAR	European Council for Automotive Research and Development
IEC	International Electrotechnical Commission
ISO	International Organization for Standardization
OCV	Open circuit voltage
PNGV	Partnership for a New Generation of Vehicles
PSD	Power spectral density
RESS	Rechargeable energy storage system
r.m.s	root-mean-square
SC	Standard cycle
SCH	Standard charge
SDCH	Standard discharge
SOC	State of charge
USABC	United States Advanced Battery Consortium

## 5 General requirements

### 5.1 General conditions

#### 5.1.1 Prerequisites

A battery pack or system tested in accordance with this part of ISO 12405 shall fulfil the following requirements.

- The electrical safety design shall be approved in accordance with the requirements given in ISO 6469-1 and ISO 6469-3.
- The necessary documentation for operation and required interface parts for connection to the test equipment (i.e. connectors, plugs, including cooling) shall be delivered together with the DUT.

A battery system shall enable the specified tests, i.e. via specified test modes implemented in the BCU, and shall be able to communicate with the test bench via common communication buses.

The battery pack subsystem as a DUT shall comprise all parts specified by the customer (e.g. including mechanical and electrical connecting points for mechanical test).

## ISO 12405-1:2011(E)

If not otherwise specified, before each test, the DUT shall be equilibrated at the test temperature. The thermal equilibration is reached, if during a period of 1 h without active cooling, the deviations between test temperature and temperature of all cell temperature measuring points are lower than  $\pm 2$  K.

If not otherwise specified, each charge and each SOC change shall be followed by a rest period of 30 min.

### 5.1.2 Accuracy of measurement equipment and measured values

The accuracy of external measurement equipment shall be at least within the following tolerances:

- a) voltage  $\pm 0,5$  %;
- b) current  $\pm 0,5$  %;
- c) temperature  $\pm 1$  K.

The overall accuracy of externally controlled or measured values, relative to the specified or actual values, shall be at least within the following tolerances:

- voltage  $\pm 1$  %;
- current  $\pm 1$  %;
- temperature  $\pm 2$  K;
- time  $\pm 0,1$  %;
- mass  $\pm 0,1$  %;
- dimensions  $\pm 0,1$  %.

All values (time, temperature, current and voltage) shall be noted at least every 5 % of the estimated discharge and charge time, except if it is noted otherwise in the individual test procedure.

### 5.2 Test sequence plan

The test sequence for an individual battery pack or system, or a battery pack subsystem shall be based on agreement between the customer and supplier with consideration of tests in 5.3.

An example of a list of test conditions to be agreed between the customer and supplier is provided in Table C.1.

### 5.3 Tests

An overview of the tests is given in Figure 1, where the references to the specific subclauses are also given.

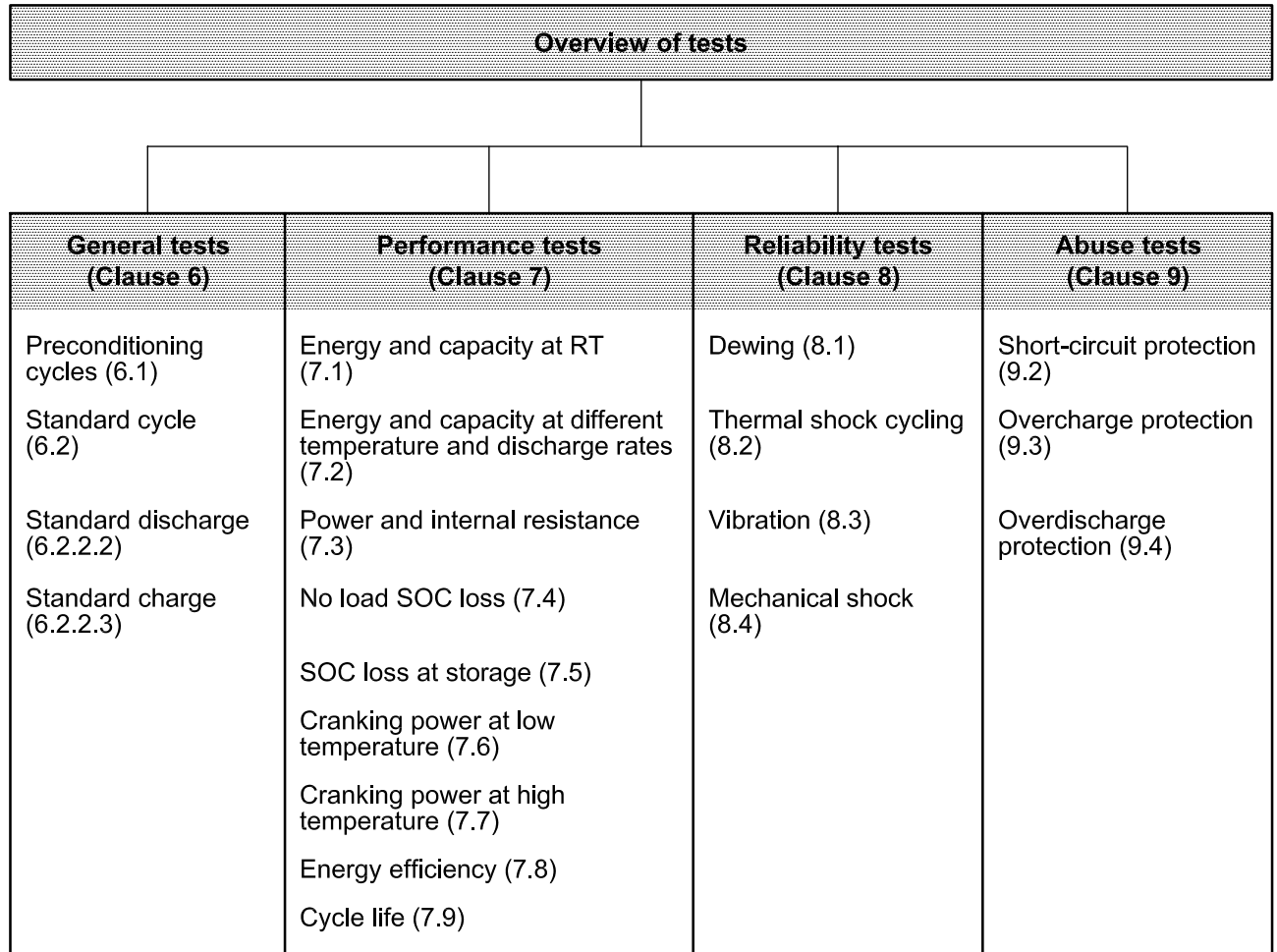

**Figure 1 — Test plan — Overview**

## 5.4 Battery pack — Typical configuration

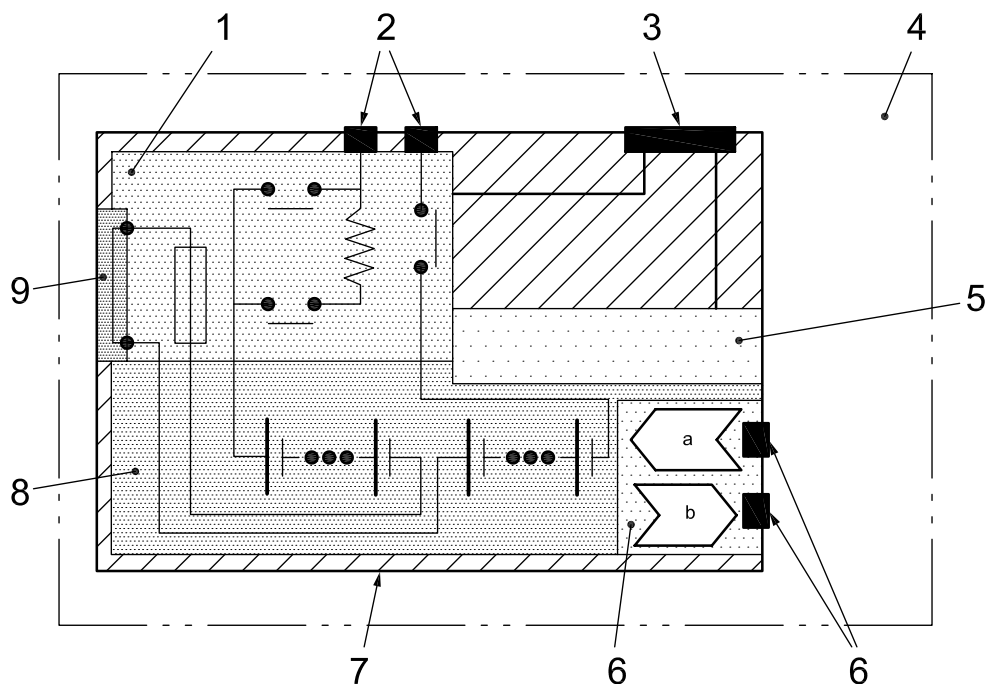

### Key

- 1 voltage class B electric circuit (connectors, fuses, wiring)
- 2 voltage class B connections
- 3 voltage class A connections
- 4 battery pack
- 5 cell electronics
- 6 cooling device and connections (optional)
- 7 normal use impact-resistant case
- 8 cell assembly (cells, sensors, cooling equipment)
- 9 service disconnect

a In.

b Out.

**Figure 2 — Typical configuration of battery pack**

A battery pack represents an energy storage device, which includes cells or cell assemblies, cell electronics, voltage class B circuit and overcurrent shut-off device, including electrical interconnections, interfaces for cooling, voltage class B, auxiliary voltage class A and communication. The voltage class B circuit of the battery pack may include contactors and a manual shut-off function (service disconnect). All components are typically placed in a normal use impact-resistant case.

## 5.5 Battery system — Typical configuration

### 5.5.1 BCU

The BCU calculates SOC and state of health, and provides battery system operational limits to the vehicle management unit. The BCU may have direct access to the main contactors of the battery system in order to interrupt the voltage class B circuit under specified conditions, e.g. overcurrent, overvoltage, low voltage and high temperature. The BCU may vary in design and implementation; it may be a single electronic unit integrated into the battery system or it may be placed outside the battery pack and connected via a communication bus or input/output lines to the battery pack. The BCU functionalities may be integrated functions of one or more vehicle control units.

## 5.5.2 Battery system with integrated BCU

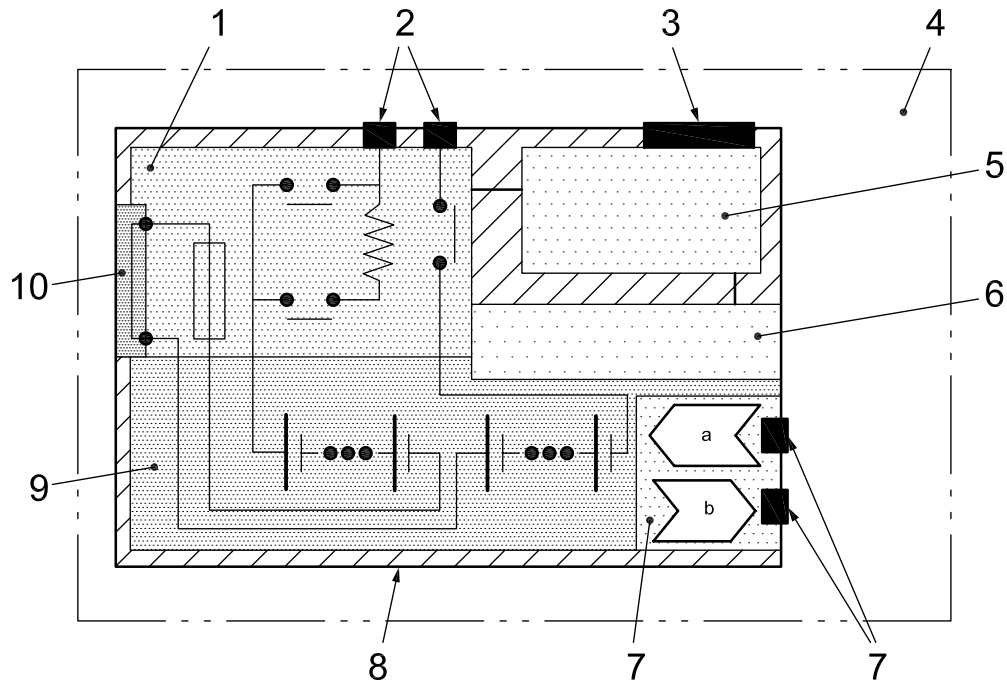
**Key**

- 1 voltage class B electric circuit (connectors, fuses, wiring)
  - 2 voltage class B connections
  - 3 voltage class A connections
  - 4 battery system
  - 5 BCU
  - 6 cell electronics
  - 7 cooling device and connections (optional)
  - 8 normal use impact-resistant case
  - 9 cell assembly (cells, sensors, cooling equipment)
  - 10 service disconnect
- a In.
- b Out.

**Figure 3 — Typical configuration of battery system with integrated BCU**

A battery system represents an energy storage device, which includes cells or cell assemblies, cell electronics, a BCU, voltage class B circuit with contactors and overcurrent shut-off device, including electrical interconnections, interfaces for cooling, voltage class B, auxiliary voltage class A and communication. The voltage class B circuit may include a manual shut-off function (service disconnect). All components are typically placed in a normal use impact-resistant case. In this example, the BCU is integrated inside the normal use impact-resistant case and connected via its control functionalities to the battery pack.

5.5.3 Battery system with external BCU

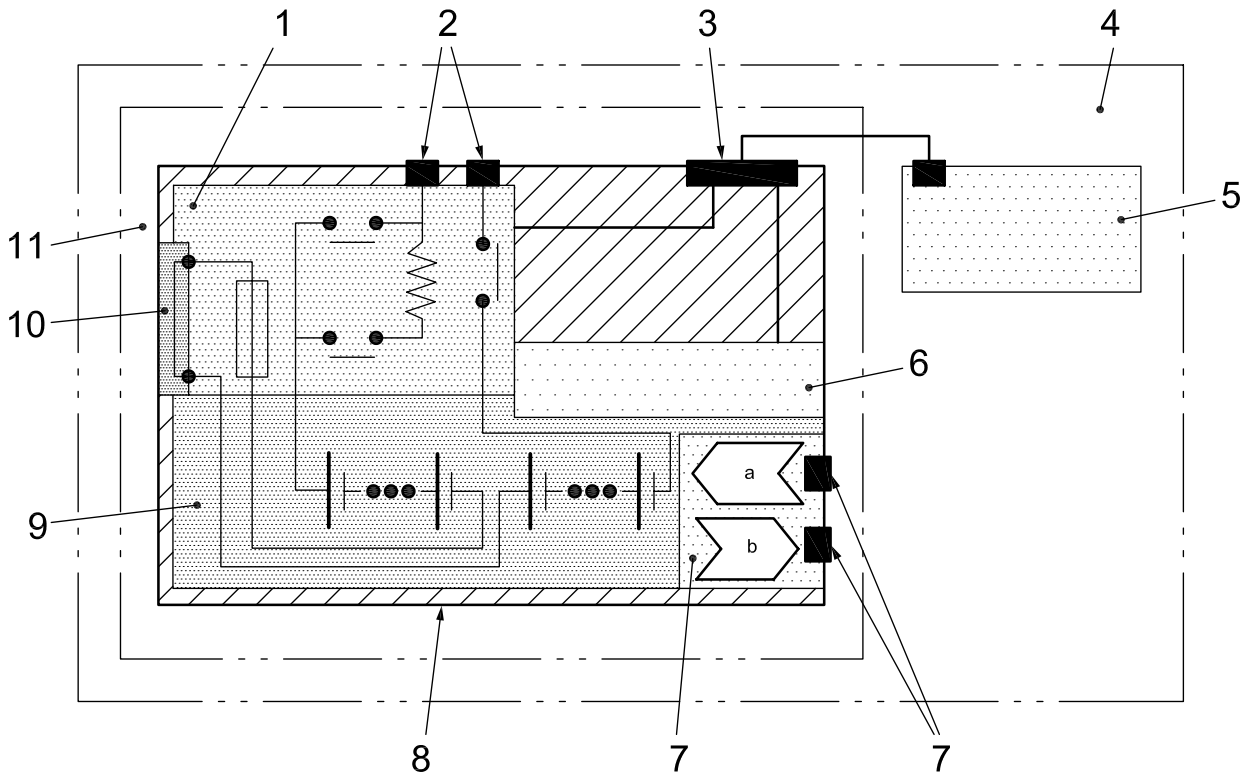

Key

- 1 voltage class B electric circuit (connectors, fuses, wiring)
  - 2 voltage class B connections
  - 3 voltage class A connections
  - 4 battery system
  - 5 BCU
  - 6 cell electronics
  - 7 cooling device and connections (optional)
  - 8 normal use impact-resistant case
  - 9 cell assembly (cells, sensors, cooling equipment)
  - 10 service disconnect
  - 11 battery pack
- a In.  
b Out.

Figure 4 — Typical configuration of battery system with external BCU

A battery system represents an energy storage device, which includes cells or cell assemblies, cell electronics, a BCU, voltage class B circuit with contactors and overcurrent shut-off device, including electrical interconnections, interfaces for cooling, voltage class B, auxiliary voltage class A and communication. The voltage class B circuit may include a manual shut-off function (service disconnect). All components are typically placed in a normal use impact-resistant case. In this example, the BCU is placed outside the normal use impact-resistant case and connected via its control functionalities to the battery pack.



## 5.6 Preparation of battery pack and system for bench testing

### 5.6.1 Preparation of battery pack

If not otherwise specified, the battery pack shall be connected with voltage class B and voltage class A connections to the test bench equipment. Contactors, available voltage, current and temperature data shall be controlled according to the battery pack supplier's requirements and according to the test specification given by the test bench equipment. The passive overcurrent protection device shall be operational in the battery pack. Active overcurrent protection shall be maintained by the test bench equipment, if necessary, via disconnection of the battery pack main contactors. The cooling device may be connected to the test bench equipment and operated according to the supplier's requirements.

### 5.6.2 Preparation of battery system

If not otherwise specified, the battery system shall be connected with voltage class B, voltage class A and cooling connections to the test bench equipment. The battery system shall be controlled by the BCU, the test bench equipment shall follow the operational limits provided by the BCU via bus communication. The test bench equipment shall maintain the on/off requirements for the main contactors and the voltage, current and temperature profiles according to the requirements of the given test procedure. The battery system cooling device and the corresponding cooling loop at the test bench equipment shall be operational according to the controls by the BCU, unless otherwise specified in the given test procedure. The BCU shall enable the test bench equipment to perform the requested test procedure within the battery system operational limits. If necessary, the BCU programme shall be adapted by the supplier for the requested test procedure. The active and passive overcurrent protection device shall be operational by the battery system. Active overcurrent protection shall be maintained also by the test bench equipment, if necessary, via request of disconnection of the battery system main contactors.

## 6 General tests

### 6.1 Preconditioning cycles

#### 6.1.1 Purpose

The DUT shall be conditioned by performing some electrical cycles before starting the real testing sequence, in order to ensure an adequate stabilization of the battery pack or system performance.

This test applies to battery packs and systems.

#### 6.1.2 Test procedure

The procedure shall be the following.

- The test shall be performed at room temperature.
- The discharges shall be performed at 2 C or at a different current if suggested and/or used by the supplier in testing before delivery. The charging shall be performed according to the recommendations of the supplier.
- Five consecutive preconditioning cycles shall be performed. Fewer cycles may be agreed between the customer and supplier.
- At the end of discharge, the battery pack or system voltage shall not go below the minimum voltage recommended by the supplier. (The minimum voltage is the lowest voltage under discharge without irreversible damage.)

- The battery pack or system shall be considered “preconditioned” if the discharged capacity during two consecutive discharges does not change by a value greater than 3 % of the rated capacity (30 min discharge or other discharge regime adopted during test according to battery supplier indications). If the discharge regime is equal to that used by the supplier on the same battery pack or system during factory tests, the data from the second cycle may be compared directly with the data from the supplier.
- If the precondition requirements cannot be fulfilled, the customer and supplier shall agree on further procedure.

NOTE The discharge rate of 2 C is used in order to shorten the preconditioning.

## 6.2 Standard cycle

### 6.2.1 Purpose

The purpose of the standard cycle (SC) is to ensure the same initial condition for each test of a battery pack or system. An SC, as described in 6.2.2.1, shall be performed prior to each test.

This test applies to battery packs and systems.

### 6.2.2 Test procedure

#### 6.2.2.1 General

The SC shall be performed at  $T_{room}$ . The SC shall comprise an SDCH (see 6.2.2.2), followed by an SCH (see 6.2.2.3).

If, for any reason, the time interval between the end of the SC and the start of a new test is longer than 3 h, the SC shall be repeated.

#### 6.2.2.2 Standard discharge

Discharge rate: 1 C or other specific discharge regime according to the specifications given by the supplier.

Discharge limit: according to the specifications given by the supplier.

Rest period after discharge to reach a stable condition: 30 min or a thermal equilibration at  $T_{room}$  of the DUT is reached.

#### 6.2.2.3 Standard charge

Charge procedure and end of charge criteria: according to the specifications given by the supplier; the specifications shall cover end of charge criteria and time limits for the overall charging procedure.

Rest period after charge to reach a stable condition: 30 min.

## 7 Performance tests

### 7.1 Energy and capacity at room temperature

#### 7.1.1 Purpose

This test measures DUT capacity in ampere hours (A·h), at constant current discharge rates corresponding to the supplier's rated 1 C capacity in ampere hours (A·h) (e.g., if the rated one-hour discharge capacity is 10 A·h, the discharge rate is 10 A). The one-hour rate (1 C) is used as reference for static capacity and energy

measurement and as a standard rate for pack and system level testing. In addition, if applicable, the 10 C and the maximum permitted C rate shall be performed for capacity determination to meet the high-power system application requirements. Discharge is terminated on supplier-specified discharge voltage limits depending on discharge rates.

This test applies to battery packs and systems.

### 7.1.2 Test procedure

The test shall be performed at  $T_{room}$ , with the discharge rates of 1 C, 10 C and the maximum C rate as permitted by the supplier (the maximum C rate corresponds to  $I_{d,max}$ ).

The test sequence shall be performed as specified in Table 1.

**Table 1 — Test sequence energy and capacity test at room temperature**

Step	Procedure	Test temperature
1.1	Thermal equilibration	$T_{room}$
1.2	Standard charge (SCH)	$T_{room}$
1.3	Standard cycle (SC)	$T_{room}$
2.1	Discharge at 1 C	$T_{room}$
2.2	Standard charge (SCH)	$T_{room}$
2.3	Discharge at 1 C	$T_{room}$
2.4	Standard charge (SCH)	$T_{room}$
2.5	Discharge at 10 C	$T_{room}$
2.6	Standard charge (SCH)	$T_{room}$
2.7	Discharge at 10 C	$T_{room}$
2.8	Standard charge (SCH)	$T_{room}$
2.9	Discharge at $I_{d,max}$	$T_{room}$
2.10	Standard charge (SCH)	$T_{room}$
2.11	Discharge at $I_{d,max}$	$T_{room}$
2.12	Standard charge (SCH)	$T_{room}$
3.1	Standard cycle (SC)	$T_{room}$

- The SCH procedure shall follow 6.2.2.3.
- The SC procedure shall follow 6.2.
- All discharge tests shall be terminated at the supplier's discharge voltage limits.
- After discharge, the DUT shall rest at least for 30 min or shall be thermally equilibrated at the required ambient temperature or a fixed time period shall be used to allow for thermal equilibration before starting the next step in the test sequence.

### 7.1.3 Requirement

If the 1 C capacity obtained during testing at 7.1.2 step no. 2.3 differs more than 5 % from the supplier's 1 C specification, this measured 1 C capacity shall be used as rated capacity and shall be the basis value for all further discharge current requirements, i.e. the value for C in each discharge current calculation,  $nC$ , shall be based on the measured 1 C capacity.

The following data shall be reported:

- current, voltage, DUT temperature and ambient temperature versus time at each discharge test and the following standard charge;
- discharged capacity, in ampere hours (A·h); energy, in watt hours (W·h) and average power, in watts (W), at each discharge test;
- charged capacity, in ampere hours (A·h); energy, in watt hours (W·h) and average power, in watts (W), followed each discharge test;
- energy round-trip efficiency at each discharge test;
- discharged energy, in watt hours (W·h), as a function of SOC at each discharge test [in per cent (%) of rated capacity];
- EODV of all available cell voltage measuring points for all performed discharge tests;
- determined 1 C rated capacity which is taken as basic value for all further discharge current requirements.

NOTE Capacity data are also used for the later calculation of capacity fades (see 7.9.2.8).

## 7.2 Energy and capacity at different temperatures and discharge rates

### 7.2.1 Purpose

This test determines the capacity at different temperatures at three different constant current discharge rates. The different discharge rates shall be performed in a sequence before the ambient temperature is changed and the test shall be repeated after the new temperature is achieved.

This test applies to battery packs and systems.

### 7.2.2 Test procedure

The test shall be performed at three different temperatures (40 °C, 0 °C and –18 °C) with the discharge rates 1 C, 10 C and the maximum C rate as permitted by the supplier (the maximum C rate corresponds to  $I_{d,max}$ ).

The test sequence shall be performed as specified in Table 2.

Table 2 — Test sequence energy and capacity test at different temperature and discharge rates

Step	Procedure	Test temperature
1.1	Thermal equilibration	$T_{\text{room}}$
1.2	Standard charge (SCH)	$T_{\text{room}}$
1.3	Standard cycle (SC)	$T_{\text{room}}$
2.1	Thermal equilibration	40 °C
2.2	Standard charge (SCH) for top off	40 °C
2.3	Discharge at 1 C	40 °C
2.4	Standard charge (SCH)	40 °C
2.5	Discharge at 1 C	40 °C
3.1	Thermal equilibration	$T_{\text{room}}$
3.2	Standard charge (SCH)	$T_{\text{room}}$
3.3	Standard cycle (SC)	$T_{\text{room}}$
4.1	Thermal equilibration	40 °C
4.2	Standard charge (SCH) for top off	40 °C
4.3	Discharge at 10 C	40 °C
4.4	Standard charge (SCH)	40 °C
4.5	Discharge at 10 C	40 °C
5.1	Thermal equilibration	$T_{\text{room}}$
5.2	Standard charge (SCH)	$T_{\text{room}}$
5.3	Standard cycle (SC)	$T_{\text{room}}$
6.1	Thermal equilibration	40 °C
6.2	Standard charge (SCH) for top off	40 °C
6.3	Discharge at $I_{d,\text{max}}$	40 °C
6.4	Standard charge (SCH)	40 °C
6.5	Discharge at $I_{d,\text{max}}$	40 °C
7.1	Thermal equilibration	$T_{\text{room}}$
7.2	Standard charge (SCH)	$T_{\text{room}}$
7.3	Standard cycle (SC)	$T_{\text{room}}$
8.1	Thermal equilibration	0 °C
8.2	Standard charge (SCH) for top off	0 °C
8.3	Discharge at 1 C	0 °C
8.4	Standard charge (SCH)	0 °C
8.5	Discharge at 1 C	0 °C
9.1	Thermal equilibration	$T_{\text{room}}$
9.2	Standard charge (SCH)	$T_{\text{room}}$
9.3	Standard cycle (SC)	$T_{\text{room}}$
10.1	Thermal equilibration	0 °C
10.2	Standard charge (SCH) for top off	0 °C

Table 2 (continued)

10.3	Discharge at 10 C	0 °C
10.4	Standard charge (SCH)	0 °C
10.5	Discharge at 10 C	0 °C
11.1	Thermal equilibration	$T_{room}$
11.2	Standard charge (SCH)	$T_{room}$
11.3	Standard cycle (SC)	$T_{room}$
12.1	Thermal equilibration	0 °C
12.2	Standard charge (SCH) for top off	0 °C
12.3	Discharge at $I_{d,max}$	0 °C
12.4	Standard charge (SCH)	0 °C
12.5	Discharge at $I_{d,max}$	0 °C
13.1	Thermal equilibration	$T_{room}$
13.2	Standard charge (SCH)	$T_{room}$
13.3	Standard cycle (SC)	$T_{room}$
14.1	Thermal equilibration	-18 °C
14.2	Standard charge (SCH) for top off	-18 °C
14.3	Discharge at 1 C	-18 °C
14.3	Standard charge (SCH)	-18 °C
14.4	Discharge at 1 C	-18 °C
15.1	Thermal equilibration	$T_{room}$
15.2	Standard charge (SCH)	$T_{room}$
15.3	Standard cycle (SC)	$T_{room}$
16.1	Thermal equilibration	-18 °C
16.2	Standard charge (SCH) for top off	-18 °C
16.3	Discharge at 10 C	-18 °C
16.4	Standard charge (SCH)	-18 °C
16.5	Discharge at 10 C	-18 °C
17.1	Thermal equilibration	$T_{room}$
17.2	Standard charge (SCH)	$T_{room}$
17.3	Standard cycle (SC)	$T_{room}$
18.1	Thermal equilibration	-18 °C
18.2	Standard charge (SCH) for top off	-18 °C
18.3	Discharge at $I_{d,max}$	-18 °C
18.4	Standard charge (SCH)	-18 °C
18.5	Discharge at $I_{d,max}$	-18 °C
19.1	Thermal equilibration	$T_{room}$
19.2	Standard charge (SCH)	$T_{room}$
19.3	Standard cycle (SC)	$T_{room}$

- The SCH procedure at the different temperatures shall follow 6.2.2.3.
- The SC procedure shall follow 6.2
- The value for the C discharge rate shall be based on the rated capacity provided by the supplier and according to the 1 C test results, as described in test procedure 7.1, respectively.
- All discharge tests shall be terminated at the supplier's discharge voltage limits.
- After discharge, the DUT shall rest at least for 30 min or shall be thermally equilibrated at the required ambient temperature or a fixed time period shall be used to allow for thermal equilibration before starting the next step in the test sequence.

NOTE The SCH for top-off enables recharging of the DUT in order to compensate for energy losses that can occur during temperature equilibration.

### 7.2.3 Requirements

The following data shall be reported:

- current, voltage, DUT temperature and ambient temperature versus time at each discharge test and the following standard charge;
- discharged capacity, in ampere hours (A·h); energy, in watt hours (W·h), and average power, in watts (W), at each discharge test;
- charged capacity, in ampere hours (A·h); energy, in watt hours (W·h), and average power, in watts (W), followed each discharge test;
- energy round-trip efficiency at each discharge test;
- discharged energy, in watt hours (W·h), as a function of SOC at each discharge test [in per cent (%) of rated capacity];
- EODV of all available cell voltage measuring points for all performed discharge tests.

## 7.3 Power and internal resistance

### 7.3.1 Purpose

The power and internal resistance test is intended to determine the dynamic power capability, the ohmic resistance for discharge and charge conditions, as well as the OCV of the DUT as a function of SOC and temperatures according to a realistic load profile derived from vehicle driving operation. The test procedure combines the FreedomCAR “Hybrid Pulse Power Characterization Test” (see Reference [6]) and the EUCAR “Internal Resistance, Open Circuit Voltage and Power Determination Test” (see Reference [5]).

This test applies to battery packs and systems.

### 7.3.2 Pulse power characterization profile

The objective of this profile is to demonstrate the discharge pulse power (0,1 s, 2 s, 10 s and 18 s) and regenerative charge pulse power (0,1 s, 2 s and 10 s) capabilities at various SOC. The test protocol uses constant current at levels derived from the supplier's maximum rated discharge pulse current,  $I_{dp,max}$ . In agreement with the customer, this value may be reduced. Only in the case where the DUT reaches the discharge voltage limit during discharge, shall the current be reduced such that the battery terminal voltage is maintained at the discharge voltage limit throughout the 18 s discharge pulse. The current of the regenerative charge pulse shall be kept constant and shall be calculated as 75 % of the discharge pulse current. Only in the case where the DUT reaches during charging the charge voltage limit, shall the current be reduced such that the battery terminal voltage is maintained at the charge voltage limit throughout the 10 s regenerative charge pulse.

The test profile shall consist of an 18 s discharge pulse followed by a 40 s rest period to allow the measurement of the cell polarization resistance. After the 40 s rest period, a 10 s charge pulse with 75 % current rate of the discharge pulse shall be performed to determine the regenerative charge capabilities. After the charge pulse, a rest period of 40 s shall follow (for timing and current, see Table 3 and Figure 5).

NOTE For the testing of battery systems, the BCU delivers, e.g. depending on actual temperature and SOC of the DUT, the maximum allowed operating limits of the DUT via bus communication to enable the test bench equipment to maintain the DUT at all times in specified operating conditions. For the testing of battery packs, the supplier is requested to deliver all necessary operating limits for the DUT in order to adjust the test bench equipment to maintain the DUT at all times in specified operating conditions.

**Table 3 — Pulse power characterization profile**

Time increment s	Time cumulative s	Current
0	0	0
18	18	$I_{dp,max}$
40	58	0
10	68	$-0,75 I_{dp,max}$
40	108	0

Figure 5 shows an example where the maximum rated discharge pulse current,  $I_{dp,max}$ , is 20 C. The discharge current is specified as positive and the charge current as negative. The maximum rated discharge pulse current,  $I_{dp,max}$ , for the pulse power characterization profile shall be specified by the supplier.

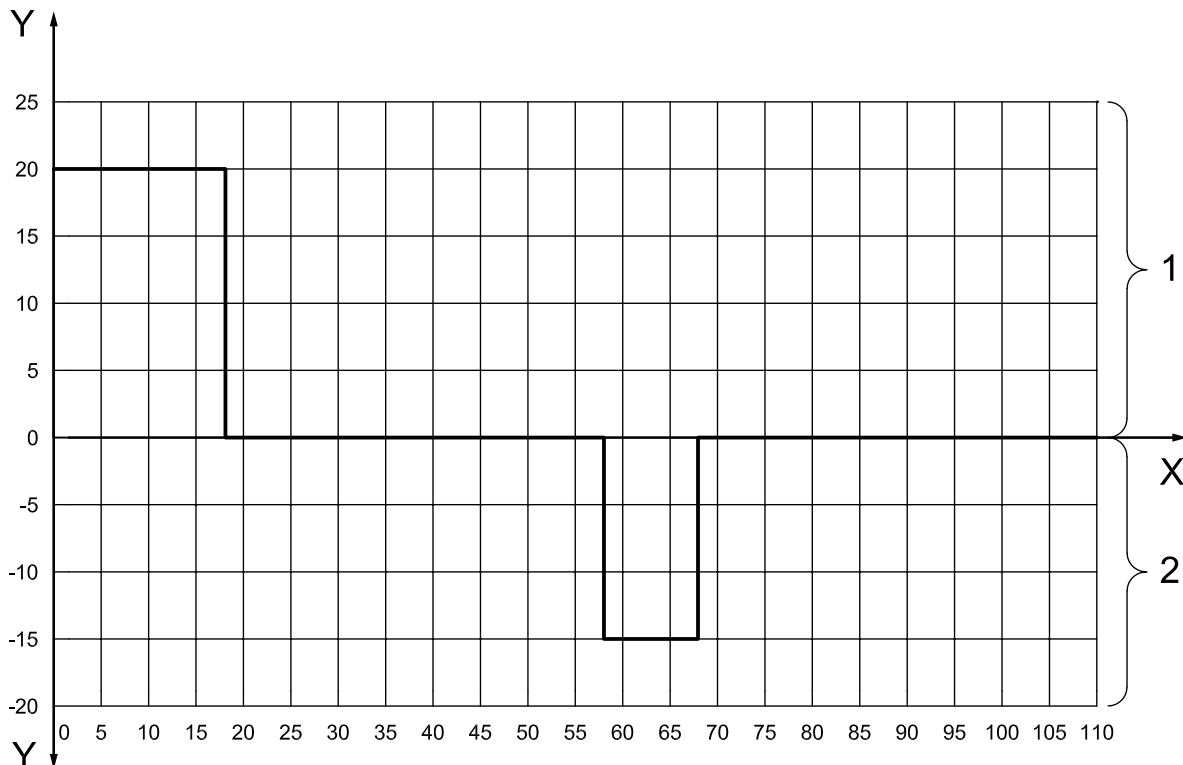

- Key**
- X time (s)
  - Y current (C rate)
  - 1 discharge
  - 2 charge

**Figure 5 — Pulse power characterization profile — Current**



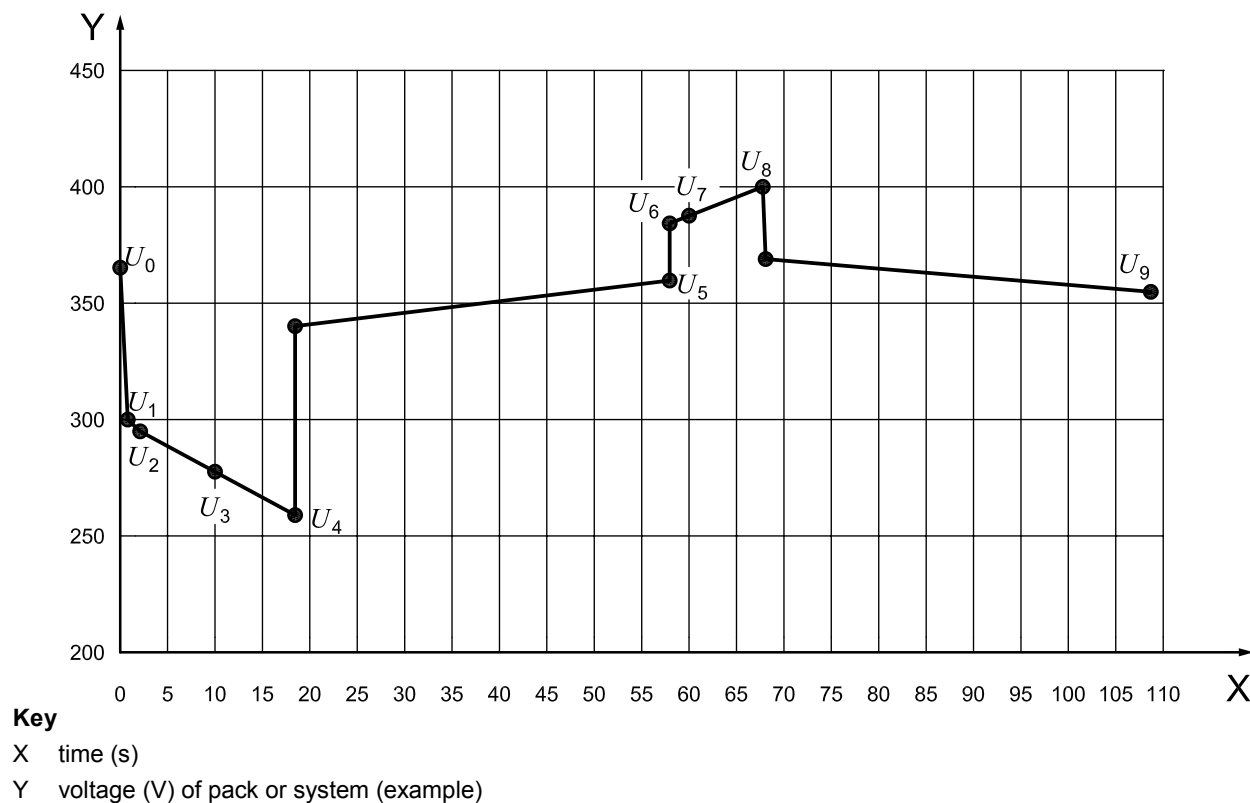

**Figure 6 — Pulse power characterization profile — Voltage**

**NOTE** The voltage values in Figure 6 are an example and expressed for pack or system level. Values can differ depending on battery chemistry, temperature, SOC, etc.

For the peak power, regenerative power and resistance determination, the battery terminal voltage and current shall be measured at the times given in Table 4.

If the test equipment cannot provide the current value with the requested accuracy at the time of 100 ms after a change in the current profile, no related values for power and resistance shall be calculated for this specific test step.

**Table 4 — Measured voltages and currents**

Time, $t$ s	Voltage	Current	Current value
0	$U_0$	$I_0$	0
0,1	$U_1$	$I_1$	$I_{dp,max}$
2	$U_2$	$I_2$	$I_{dp,max}$
10	$U_3$	$I_3$	$I_{dp,max}$
18	$U_4$	$I_4$	$I_{dp,max}$
58	$U_5$	$I_5$	0
58,1	$U_6$	$I_6$	$-0,75 I_{dp,max}$
60	$U_7$	$I_7$	$-0,75 I_{dp,max}$
68	$U_8$	$I_8$	$-0,75 I_{dp,max}$
108	$U_9$	$I_9$	0

The following calculations for resistance and power shall be performed according to Table 5:

**Table 5 — Calculation of resistance and power**

Value	Equation	$\Delta t$ s
0,1 s discharge resistance	$Ri_{0,1s,dch} = (U_0 - U_1)/I_1$	0,1
2 s discharge resistance	$Ri_{2s, ch} = (U_0 - U_2)/I_2$	2
10 s discharge resistance	$Ri_{10s,dch} = (U_0 - U_3)/I_3$	10
18 s discharge resistance	$Ri_{18s,dch} = (U_0 - U_4)/I_4$	18
overall discharge resistance	$Ri_{dch} = (U_5 - U_4)/I_4$	40
0,1 s charge resistance	$Ri_{0,1s,cha} = (U_5 - U_6)/I_6$	0,1
2 s charge resistance	$Ri_{2s,cha} = (U_5 - U_7)/I_7$	2
10 s charge resistance	$Ri_{10s,cha} = (U_5 - U_8)/I_8$	10
overall charge resistance	$Ri_{cha} = (U_9 - U_8)/I_8$	40
0,1 s discharge power	$P_{0,1s,dch} = U_1 \times I_1$	0,1
2 s discharge power	$P_{2s,dch} = U_2 \times I_2$	2
10 s discharge power	$P_{10s,dch} = U_3 \times I_3$	10
18 s discharge power	$P_{18s,dch} = U_4 \times I_4$	18
0,1 s regenerative power	$P_{0,1s,cha} = U_6 \times I_6$	0,1
2 s regenerative power	$P_{2s,cha} = U_7 \times I_7$	2
10 s regenerative power	$P_{10s,cha} = U_8 \times I_8$	10
open circuit voltage	$U_{OCV} = U_0$	

**7.3.3 Test procedure**

The test shall be performed at five different temperatures (40 °C,  $T_{room}$ , 0 °C, -10 °C and -18 °C) and shall cover an SOC range of 80 % to 20 % within five steps (80 %, 65 %, 50 %, 35 %, 20 %), whereas the last step at 20 % SOC shall only be performed if the maximum discharge current of the DUT is equal to or less than a 10 C current rate in order to avoid a deep discharge of the DUT.

- Prior to each test temperature, the DUT shall be conditioned at  $T_{room}$  in accordance with the thermal equilibration requirements provided in 5.1, followed by an SCH as provided in 6.2.2.3 for top off and an SC as provided in 6.2.
- Then, the DUT shall be conditioned at the specified test temperature in accordance with the thermal equilibration requirements provided in 5.1, followed by an SCH as provided in 6.2.2.3. The SCH is required in order to condition the DUT to 100 % SOC at the specified test temperature prior to the pulse power characterization test profile.
- In the next step, the fully charged DUT shall be discharged with a 1 C rate to the initial SOC of 80 % followed by a minimum 30 min rest period.
- Then, the pulse power characterization profile as described in 7.3.2 shall be performed.
- The next SOC steps (65 %, 50 %, 35 % and 20 %) shall be reached by a 1 C discharge followed by a 30 min rest period. Then, the pulse power characterization profile as described in 7.3.2 shall be performed at each mentioned SOC step.

NOTE The last step at 20 % SOC is performed only if possible.

- At the end of the pulse power characterization profile, at the 20 % SOC level, the SCH shall be performed.

Data sampling, especially for DUT voltage and current shall be performed with an adequate sampling rate, e.g. 10 ms.

The complete test sequence shall be performed as specified in Table 6.

**Table 6 — Test sequence power and internal resistance test**

Step	Procedure	Test temperature
1.1	Thermal equilibration	$T_{\text{room}}$
1.2	Standard charge (SCH) for top off	$T_{\text{room}}$
1.3	Standard cycle (SC)	$T_{\text{room}}$
2.1	Thermal equilibration	$T_{\text{room}}$
2.2	Standard charge (SCH) for top off	$T_{\text{room}}$
2.3	Pulse power characterization	$T_{\text{room}}$
2.4	Standard charge (SCH)	$T_{\text{room}}$
3.1	Thermal equilibration	$T_{\text{room}}$
3.2	Standard charge (SCH) for top off	$T_{\text{room}}$
3.3	Standard cycle (SC)	$T_{\text{room}}$
4.1	Thermal equilibration	40 °C
4.2	Standard charge (SCH) for top off	40 °C
4.3	Pulse power characterization	40 °C
4.4	Standard charge (SCH)	40 °C
5.1	Thermal equilibration	$T_{\text{room}}$
5.2	Standard charge (SCH) for top off	$T_{\text{room}}$
5.3	Standard cycle (SC)	$T_{\text{room}}$
6.1	Thermal equilibration	0 °C
6.2	Standard charge (SCH) for top off	0 °C
6.3	Pulse power characterization	0 °C
6.4	Standard charge (SCH)	0 °C
7.1	Thermal equilibration	$T_{\text{room}}$
7.2	Standard charge (SCH) for top off	$T_{\text{room}}$
7.3	Standard cycle (SC)	$T_{\text{room}}$
8.1	Thermal equilibration	-10 °C
8.2	Standard charge (SCH) for top off	-10 °C
8.3	Pulse power characterization	-10 °C
8.4	Standard charge (SCH)	-10 °C
9.1	Thermal equilibration	$T_{\text{room}}$
9.2	Standard charge (SCH) for top off	$T_{\text{room}}$
9.3	Standard cycle (SC)	$T_{\text{room}}$
10.1	Thermal equilibration	-18 °C
10.2	Standard charge (SCH) for top off	-18 °C
10.3	Pulse power characterization	-18 °C
10.4	Standard charge (SCH)	-18 °C

Table 6 (continued)

Step	Procedure	Test temperature
11.1	Thermal equilibration	$T_{room}$
11.2	Standard charge (SCH) for top off	$T_{room}$
11.3	Standard cycle (SC)	$T_{room}$
12.1	Thermal equilibration	$T_{room}$
12.2	Standard charge (SCH) for top off	$T_{room}$
12.3	Pulse power characterization	$T_{room}$
12.4	Standard charge (SCH)	$T_{room}$

- The SCH procedure at the different temperatures shall follow 6.2.2.3.
- The SC procedure shall follow 6.2
- All discharge tests shall be terminated at the supplier's discharge voltage limits.

NOTE The SCH for top off enables the recharging of the DUT in order to compensate for energy losses that can occur during temperature equilibration

**7.3.4 Requirements**

The following data shall be delivered by using the equations described in Table 5:

- discharge power for 0,1 s, 2 s, 10 s and 18 s peaks as a function of the SOC and temperature;
- regenerative power for 0,1 s, 2 s and 10 s peaks as a function of the SOC and temperature;
- discharge resistance for 0,1 s, 2 s, 10 s and 18 s peaks as well as the overall resistance as a function of SOC and temperature;
- charge resistance for 0,1 s, 2 s and 10 s peaks as well as the overall resistance as a function of the SOC and temperature;
- open circuit voltage as a function of the SOC and temperature;
- deviation from first and last test at  $T_{room}$ , if any;
- if it was necessary to reduce the charge or discharge current due to voltage limits, the calculated internal resistance values shall be marked clearly in the test report and in the result tables.

**7.4 No-load SOC loss**

**7.4.1 Purpose**

The purpose of this test is to measure the SOC loss of a battery system if it is not used for an extended period of time. This test refers to a scenario in which a vehicle is not driven for a long time period and, therefore, the battery system could not be placed on charge. The no-load SOC loss, if it occurs, may be due to self discharge, which is normally temporary, or to other mechanisms that can produce permanent or semi-permanent loss of SOC.

This test applies to battery systems only.

### 7.4.2 Test procedure

The no-load SOC loss shall be measured with a complete and fully operational battery system. The BCU shall be supplied with the necessary auxiliary power (e.g. 12 V d.c. power supply) in order to be able to control necessary battery system functions during the rest period, for example

- a) battery system cell balancing, and
- b) periodical BCU wake-up activities.

The no-load SOC loss rate(s) shall include any possible parasitic or operational discharge contribution of the cell balancing circuitry itself beyond the inherent self-discharge rate of the battery cells themselves.

The no-load SOC loss rate of the battery system shall be measured for three different rest periods and at two different temperatures. The battery system is discharged to 80 % SOC (or to an SOC agreed between the supplier and customer) and then left at open circuit for a certain time. The BCU shall be able to perform control activities (e.g. cell balancing and regular wake-up activities). After the rest period, the remaining SOC shall be determined by a 1 C discharge at  $T_{room}$ .

The tests shall be performed in a temperature-controlled test chamber at the given temperatures. Before each test cycle at a given temperature, the battery shall be kept at the test temperature for a minimum of 12 h. This period can be reduced if thermal equilibration is reached, specified as less than 4 K change among individual cell temperatures during an interval of 1 h.

- Temperatures:  $T_{room}$  and 40 °C;
- Standard cycle: to ensure that each test is done with the battery system in the same initial condition, an SC (see 6.2) shall be performed prior to each test;
- Discharge rate: discharge the battery system to 80 % SOC (or to an SOC agreed between the supplier and customer) at 1 C rate;
- Rest period: 24 h (1 day), 168 h (7 days) and 720 h (30 days);
- Auxiliary energy: auxiliary energy consumption (e.g. 12 V d.c. level) for the BCU and, if required, for other battery system electronics shall be measured continuously and expressed in watt hours (W·h) for each rest period.

### 7.4.3 Test sequence

- a) First test sequence: rest period at  $T_{room}$ .

**Table 7 — Test sequence no-load SOC loss at room temperature**

Step	Procedure	Test temperature
1.1	Thermal equilibration	$T_{room}$
1.2	Standard charge (SCH)	$T_{room}$
1.3	Standard cycle (SC)	$T_{room}$
1.4	Discharge 1 C to 80 % SOC	$T_{room}$
1.5	Rest period with open voltage class B circuit for 24 h	$T_{room}$
1.6	Standard cycle (SC)	$T_{room}$
1.7	Discharge 1 C to 80 % SOC	$T_{room}$
1.8	Rest period with open voltage class B circuit for 168 h	$T_{room}$
1.9	Standard cycle (SC)	$T_{room}$
1.10	Discharge 1 C to 80 % SOC	$T_{room}$
1.11	Rest period with open voltage class B circuit for 720 h	$T_{room}$
1.12	Standard cycle (SC)	$T_{room}$

All discharge tests shall be terminated if the supplier's requested discharge voltage limits are reached.

- b) Second test sequence: rest period at 40 °C (or higher according to agreement between the supplier and customer)

**Table 8 — Test sequence no-load SOC loss at 40 °C (or higher)**

Step	Procedure	Test temperature
2.1	Thermal equilibration	$T_{room}$
2.2	Standard charge (SCH)	$T_{room}$
2.3	Standard cycle (SC)	$T_{room}$
2.4	Discharge 1 C to 80 % SOC	$T_{room}$
2.5	Rest period with open voltage class B circuit for 24 h	40 °C (or higher)
2.6	Thermal equilibration	$T_{room}$
2.7	Standard cycle (SC)	$T_{room}$
2.8	Discharge 1 C to 80 % SOC	$T_{room}$
2.9	Rest period with open voltage class B circuit for 168 h	40 °C (or higher)
2.10	Thermal equilibration	$T_{room}$
2.11	Standard cycle (SC)	$T_{room}$
2.12	Discharge 1 C to 80 % SOC	$T_{room}$
2.13	Rest period with open voltage class B circuit for 720 h	40 °C (or higher)
2.14	Thermal equilibration	$T_{room}$
2.15	Standard cycle (SC)	$T_{room}$

All discharge tests shall be terminated if the supplier's requested discharge voltage limits are reached.

**7.4.4 Requirement**

The remaining 1 C energy and SOC from the initial 80 % SOC shall be reported. The loss of energy and the SOC after each rest period shall be expressed as a percentage of the initial 80 % SOC.

The auxiliary energy consumption (12 V d.c. level) for the BCU and, if required for other battery system electronics, shall be expressed in watt hours (W·h) for each rest period.

A graph, including data for the three rest periods and the two test temperatures, showing residual capacity versus rest period, shall be presented.

**7.5 SOC loss at storage**

**7.5.1 Purpose**

The purpose of this test is to measure the SOC loss at storage of a battery system if it is stored for an extended period of time. This test refers to a scenario in which the battery system is shipped from a supplier to a customer. This SOC loss at storage, if it occurs, may be due to self-discharge, which is normally temporary, or to other mechanisms which can produce permanent or semi-permanent loss of the SOC.

This test applies to battery systems only.

### 7.5.2 Test procedure

The SOC loss at storage behaviour shall be measured with a complete and fully operational battery system. During the storage period, all battery system terminals shall be disconnected (e.g. voltage class B connections, voltage class A connection and cooling). The service disconnect device, if any, shall be disconnected.

The SOC loss at storage of the battery system shall be measured after a 720 h (30 days) rest period at 45 °C ambient temperature with an initial SOC of 50 %. The remaining capacity after the storage period shall be determined by a 1 C discharge.

The SOC loss at storage test shall be performed in a temperature controlled test chamber.

- Temperature: 45 °C;
- Standard cycle: to ensure that each test is done with the battery system in the same initial condition, an SC (see 6.2) shall be performed prior to the capacity loss at storage test;
- Discharge rate: discharge the battery system to 50 % SOC at 1 C rate;
- Rest period: 720 h (30 days);
- Auxiliary energy: during the storage period, all connections at the battery system are disconnected;
- Service disconnect: service disconnect device, if any, shall be disconnected.

### 7.5.3 Test sequence

**Table 9 — Test sequence SOC loss at storage**

Step	Procedure	Test temperature
1	Thermal equilibration	$T_{\text{room}}$
2	Standard charge (SC)	$T_{\text{room}}$
3	Standard cycle (SC)	$T_{\text{room}}$
4	Discharge 1 C to 50 % SOC	$T_{\text{room}}$
5	Rest period for 720 h, all voltage class B and voltage class A terminals are disconnected, service disconnect is disconnected	45 °C
6	Thermal equilibration	$T_{\text{room}}$
7	Standard cycle (SC)	$T_{\text{room}}$

All discharge tests shall be terminated if the supplier's requested discharge voltage limits are reached.

NOTE The remaining SOC is measured within step 7 during the SDCH test, which is the first part of the SC test.

### 7.5.4 Requirement

The remaining 1 C energy and the SOC from the initial 50 % SOC shall be reported. The loss of energy and the SOC after the rest period shall be expressed as a percentage of the initial 50 % SOC.

## 7.6 Cranking power at low temperature

### 7.6.1 Purpose

The cranking power test at low temperatures is intended to measure the power capability at low temperatures. The relevant temperatures shall be  $-18\text{ °C}$  and, if agreed between the supplier and customer, also  $-30\text{ °C}$ . The aim is to generate a database of time-dependent power output at low temperatures.

This test applies to battery systems only.

### 7.6.2 Test procedure

The test for cranking power at  $-18\text{ °C}$  shall be performed at the lowest SOC level permitted, as specified by the supplier according to the test sequence in Table 10.

**Table 10 — Test sequence cranking power at low temperature ( $-18\text{ °C}$ )**

Step	Procedure	Test temperature
1.1	Thermal equilibration	$T_{\text{room}}$
1.2	Standard charge (SCH)	$T_{\text{room}}$
1.3	Standard cycle (SC)	$T_{\text{room}}$
1.4	Discharge the fully charged DUT at a 1 C discharge rate to 20 % SOC or the lowest SOC level allowable as specified by the supplier (minimum SOC)	$T_{\text{room}}$
1.5	Thermal equilibration	$-18\text{ °C}$
1.6	Set constant voltage of test bench to the lowest permitted system discharge voltage level according to the supplier's recommendation for 5 s and monitor the power versus time profile. The maximum current shall not exceed the supplier's specification.	$-18\text{ °C}$
1.7	Rest period with open voltage class B circuit for 10 s	$-18\text{ °C}$
1.8	Repeat steps 1.6 to 1.7 twice	$-18\text{ °C}$
1.9	Thermal equilibration	$T_{\text{room}}$
1.10	Standard charge (SCH)	$T_{\text{room}}$

The sampling rate for test data during testing shall be  $\leq 50\text{ ms}$ .

If agreed between the supplier and customer, the test for cranking power shall also be performed at  $-30\text{ °C}$  at the lowest SOC level permitted, as specified by the supplier according to the test sequence in Table 11.

**Table 11 — Test sequence cranking power at low temperature ( $-30\text{ °C}$ )**

Step	Procedure	Test temperature
2.1	Thermal equilibration	$T_{\text{room}}$
2.2	Standard charge (SCH)	$T_{\text{room}}$
2.3	Standard cycle (SC)	$T_{\text{room}}$
2.4	Discharge the fully charged DUT at a 1 C discharge rate to 20 % SOC or the lowest SOC level allowable as specified by the supplier (minimum SOC)	$T_{\text{room}}$
2.5	Thermal equilibration	$-30\text{ °C}$



Table 11 (continued)

Step	Procedure	Test temperature
2.6	Set constant voltage of test bench to the lowest permitted system discharge voltage level according to the supplier's recommendation for 5 s and monitor the power versus time profile. The maximum current shall not exceed the supplier's specification.	-30 °C
2.7	Rest period with open voltage class B circuit for 10 s	-30 °C
2.8	Repeat steps 2.6 to 2.7 twice	-30 °C
2.9	Thermal equilibration	$T_{\text{room}}$
2.10	Standard charge (SCH)	$T_{\text{room}}$

The sampling rate for test data during testing shall be  $\leq 50$  ms.

Table 12 — Voltage limits for cranking power at low temperature

Time increment s	Cumulative time s	Applicable DUT voltage V
5	5	Lowest permitted system discharge voltage
10	15	Open voltage class B circuit
5	20	Lowest permitted system discharge voltage
10	30	Open voltage class B circuit
5	35	Lowest permitted system discharge voltage
10	45	Open voltage class B circuit

The profile pulses shall be performed for the full 5 s duration (even if the test power has to be limited to stay within the minimum permitted discharge voltage) to permit the later calculation of low-temperature cranking power capability (see Table 12).

### 7.6.3 Requirement

The results shall be delivered as graphic representations of power versus time profiles, including current, voltage and temperature values.

## 7.7 Cranking power at high temperature

### 7.7.1 Purpose

The test for cranking power at high temperature is intended to measure power capabilities at a high temperature of 50 °C or the maximum temperature specified by the supplier. The aim is to generate a database of time-dependent power output at high temperatures.

This test applies to battery systems only.

### 7.7.2 Test procedure

The test for cranking power at 50 °C shall be performed at the lowest SOC level permitted as specified by the supplier according to the test sequence in Table 13.

**Table 13 — Test sequence cranking power at high temperature (50 °C)**

Step	Procedure	Test temperature
1.1	Thermal equilibration	$T_{room}$
1.2	Standard charge (SCH)	$T_{room}$
1.3	Standard cycle (SC)	$T_{room}$
1.4	Discharge the fully charged DUT at a 1 C discharge rate to 20 % SOC or the lowest SOC level allowable as specified by the supplier (minimum SOC).	$T_{room}$
1.5	Thermal equilibration	50 °C (or max. temperature specified by the supplier)
1.6	Set constant voltage of test bench to the lowest permitted system discharge voltage level according to the supplier's recommendation for 5 s and monitor the power versus time profile. The maximum current shall not exceed the supplier's specification.	50 °C (or max. temperature specified by the supplier)
1.7	Rest period with open voltage class B circuit for 10 s	50 °C (or max. temperature specified by the supplier)
1.8	Repeat steps 1.6 to 1.7 twice	50 °C (or max. temperature specified by the supplier)
1.9	Thermal equilibration	$T_{room}$
1.10	Standard charge (SCH)	$T_{room}$
1.11	Standard cycle (SC)	$T_{room}$

The sampling rate for test data during testing shall be  $\leq 50$  ms.

**Table 14 — Voltage limits for cranking power at high temperature**

Time increment s	Time cumulative s	Applicable DUT voltage and current V and A
5	5	Lowest permitted system discharge voltage and maximum permitted discharge current
10	15	Open circuit
5	20	Lowest permitted system discharge voltage and maximum permitted discharge current
10	30	Open circuit
5	35	Lowest permitted system discharge voltage and maximum permitted discharge current

The profile pulses according to Table 13 shall be performed for the full 5 s duration (even if it is necessary to limit the test power to stay within the minimum permitted discharge voltage) to permit the later calculation of the cranking power capability at high temperature.

### 7.7.3 Requirement

The results shall be delivered as graphic representations of power versus time profiles including current, voltage and temperature values.

## 7.8 Energy efficiency

### 7.8.1 Purpose

The purpose of the energy efficiency test is to determine the battery system round-trip efficiency by calculation from a charge balanced pulse profile. For high-power application, the energy efficiency of the used battery system has a significant influence on the overall vehicle efficiency. It directly affects the fuel consumption and emission levels of a vehicle equipped with a battery system for high-power application.

This test applies to battery systems only.

### 7.8.2 Test description

The test simulates the following driving situation: for acceleration, for example on to a highway or during the overtaking process, the vehicle driver requests the maximum vehicle power (max. battery discharge power). Following that, there is a cruising phase without battery performance for an assumed time of 40 s. After that, there is a regenerative braking period assumed for 10 s to recharge the battery. Of course, the actual demands are different because the drive systems of the vehicle suppliers differ, but for reasons of comparison and evaluation of battery pack and systems, it is a common base.

### 7.8.3 Test procedure

The following conditions apply:

- $T_{\text{room}}$ , 40 °C, 0 °C;
- three different SOC: 65 %, 50 %, 35 %;
- 30 min rest period before each power pulse sequence application for equilibrium;
- adequate rest period (see general conditions in 5.1) after temperature change for thermal equilibration;
- current profile for energy efficiency characterization as described in Table 15.

**Table 15 — Energy efficiency test profile**

Time increment s	Time cumulative s	Current A
0	0	0
12	12	20 C or $I_{\text{dp,max}}$
40	52	0
16	68	-15 C or $-0,75 I_{\text{dp,max}}$
40	108	0

The charge balance (A·h) during this current profile pulse sequence shall be neutral. That means the recharged capacity shall be exactly the same as the discharged capacity before. In case of voltage limitations and current degradations during the power pulse sequence, only the charge neutral periods shall be evaluated. This case shall be indicated clearly in the reported results.

Evaluation:

- energy during discharge pulse: integration of voltage and discharge current over time;
- energy during charge pulse: integration of voltage and charge current over time.

The efficiency,  $\eta$ , expressed as a percentage, is calculated as the ratio of the energy during the discharge pulse divided by the energy of the charge pulse, as given in Equation (1):

$$\eta = \frac{\left| \int_{t_{\text{start}}}^{t_{\text{end}}} U \times I_{\text{discharge}} \times dt \right|}{\left| \int_{t_{\text{start}}}^{t_{\text{end}}} U \times I_{\text{charge}} \times dt \right|} \times 100 \tag{1}$$

Expected values are between 75 % and 90 %, depending on chemistry and system.

**Table 16 — Test sequence energy efficiency test**

Step	Procedure	Test temperature
1.1	Thermal equilibration	$T_{\text{room}}$
1.2	Standard charge (SCH)	$T_{\text{room}}$
1.3	Standard cycle (SC)	$T_{\text{room}}$
2.1	Discharge with 1 C to SOC 65 %	$T_{\text{room}}$
2.2	Rest period for 30 min with open voltage class B circuit	$T_{\text{room}}$
2.3	Energy efficiency test at SOC 65 %	$T_{\text{room}}$
2.4	Discharge with 1 C to SOC 50 %	$T_{\text{room}}$
2.5	Rest period for 30 min with open voltage class B circuit	$T_{\text{room}}$
2.6	Energy efficiency test at SOC 50 %	$T_{\text{room}}$
2.7	Discharge with 1 C to SOC 35 %	$T_{\text{room}}$
2.8	Rest period for 30 min with open voltage class B circuit	$T_{\text{room}}$
2.9	Energy efficiency test at SOC 35 %	$T_{\text{room}}$
3.1	Standard cycle (SC)	$T_{\text{room}}$
3.2	Thermal equilibration	40 °C
4.1	Discharge with 1 C to SOC 65 %	40 °C
4.2	Rest period for 30 min with open voltage class B circuit	40 °C
4.3	Energy efficiency test at SOC 65 %	40 °C
4.4	Discharge with 1 C to SOC 50 %	40 °C
4.5	Rest period for 30 min with open voltage class B circuit	40 °C
4.6	Energy efficiency test at SOC 50 %	40 °C
4.7	Discharge with 1 C to SOC 35 %	40 °C
4.8	Rest period for 30 min with open voltage class B circuit	40 °C
4.9	Energy efficiency test at SOC 35 %	40 °C
5.1	Thermal equilibration	$T_{\text{room}}$
5.2	Standard cycle (SC)	$T_{\text{room}}$
5.3	Thermal equilibration	0 °C

Table 16 — (Continued)

Step	Procedure	Test temperature
6.1	Discharge with 1 C to SOC 65 %	0 °C
6.2	Rest period for 30 min with open voltage class B circuit	0 °C
6.3	Energy efficiency test at SOC 65 %	0 °C
6.4	Discharge with 1 C to SOC 50 %	0 °C
6.5	Rest period for 30 min with open voltage class B circuit	0 °C
6.6	Energy efficiency test at SOC 50 %	0 °C
6.7	Discharge with 1 C to SOC 35 %	0 °C
6.8	Rest period for 30 min with open voltage class B circuit	0 °C
6.9	Energy efficiency test at SOC 35 %	0 °C
7.1	Thermal equilibration	$T_{\text{room}}$
7.2	Standard charge (SCH)	$T_{\text{room}}$
7.3	Standard cycle (SC)	$T_{\text{room}}$

The sampling rate for test data during testing shall be  $\leq 50$  ms.

#### 7.8.4 Requirement

The following data shall be reported: energy efficiency at SOC 65 %, 50 % and 35 % for the test temperatures  $T_{\text{room}}$ , 40 °C and 0 °C.

#### 7.8.5 Calculation example for energy efficiency test

Based on a fictive 300 V battery with 6 A·h capacity, the results shall correspond (estimated) to the following data:

— discharge/charge during 12 s discharge at 20C:	0,4 A·h;
— electrical power assist (e.g.):	32,40 kW;
— regenerative power (e.g.):	39,60 kW;
— SOC swing:	6,667 %;
— energy output during 12 s discharge at 20C (e.g.):	108 W·h;
— energy input during 16 s charge at 15C (e.g.):	132 W·h;
— energy efficiency	81,8 %.

NOTE These values seem realistic, appearing during typical acceleration or boost phases during driving.

### 7.9 Cycle life

#### 7.9.1 Purpose

In addition to other ageing factors (i.e. time, temperature), the energy throughput has a significant influence on the lifetime of a battery.

In order to choose a relevant ageing profile relating to the energy throughput, real driving conditions shall be considered. That means the applied high C rates and SOC swing shall cover the vehicle demands in a realistic way. Further, the usable SOC range shall be covered by the energy cycling test. This is important in order to get reliable and significant data for lifetime prediction.

On the other hand, the battery system shall not be stressed excessively. Therefore, the thermal management and monitoring of the battery system is mandatory; in addition, certain rest phases are needed for equilibrium and cell balancing.

This test applies to battery systems only.

## 7.9.2 Test procedure

### 7.9.2.1 Preparation

During the test, it is necessary to maintain the DUT temperature, using its cooling equipment, within a temperature range of between  $T_{room}$  and 40 °C (i.e.  $T_{room}$  during rest periods, certain higher temperatures during operation). If requested by the supplier, additional rest periods may be placed between the cycles in order to keep the DUT within the designated temperature range.

The cycle life test is performed by combining two test profiles, one is the “discharge-rich profile”, where the discharge amount is slightly larger than the charge amount, as shown in Table 18 and Figure 7, and another one is the “charge-rich profile”, where the charge amount is slightly larger than the discharge amount, as shown in Table 19 and Figure 8.

The SOC swing range shall be defined by the customer; otherwise, the cycle life test shall be performed between 30 % and 80 % SOC.

By combining the two profiles, the SOC swing range can be utilized over the cycling test. The cycle life test shall be started from the upper limit of SOC with the discharge-rich profile and once the SOC reaches the lower limit or the battery voltage reaches the lower voltage limit specified by the supplier, the profile shall be switched to the charge-rich profile and continued until the upper SOC limit or voltage limit is reached (see Figure 9).

The SOC limit for altering the profiles can be detected by one of the following:

- SOC calculated, i.e. by the BCU;
- number of cycles ( $\Delta$ SOC per cycle equal to 1,944 %);
- ampere hours (A·h), counted by external measurement;
- battery voltage upper and lower limit defined by the supplier.

After 22 h of cycling, 2 h of rest shall be taken to allow certain equilibrium within the cell chemistry and to bring all cells to a voltage balanced status (this is normally performed by the integrated cell voltage balancing circuitry), followed by the performance check.

7.9.2.2 Test profile cycle life test

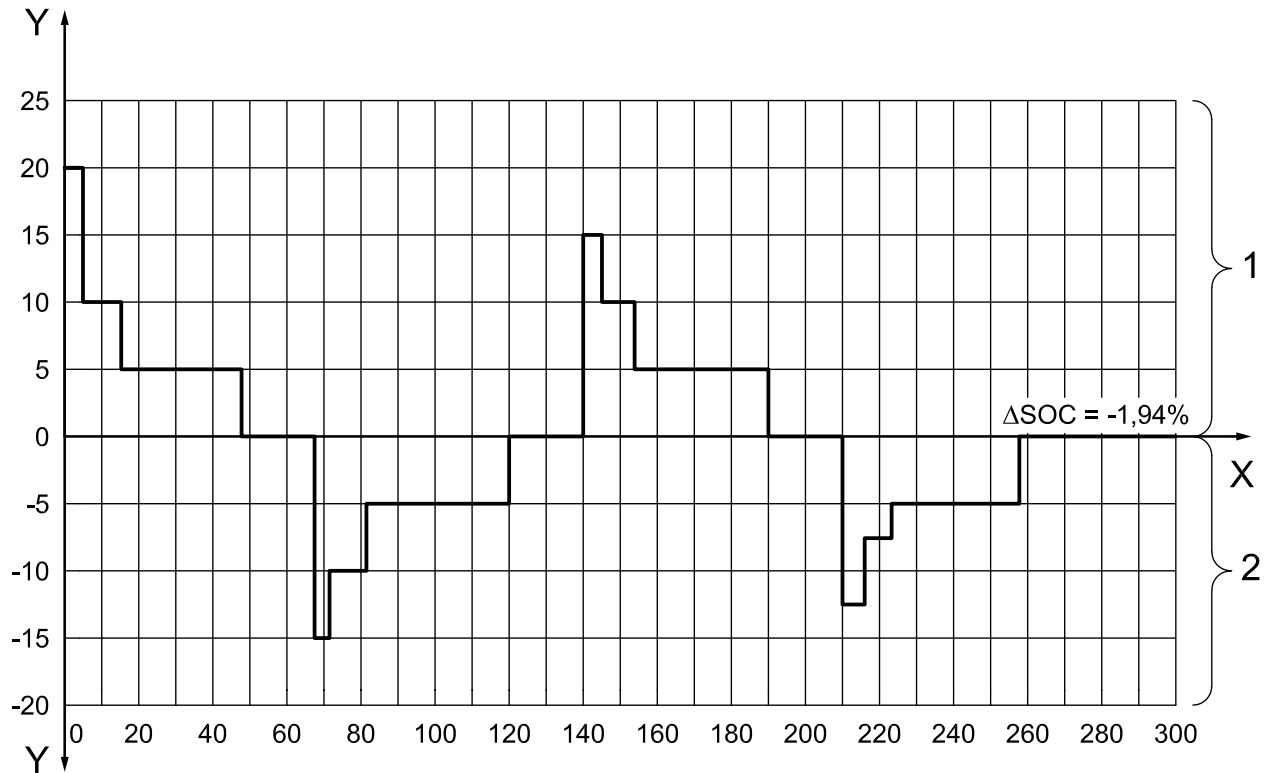

Key

- X time (s)
- Y current (C rate)
- 1 discharge
- 2 charge

Figure 7 — Current profile for cycle life test — Discharge-rich profile

Table 17 — Times and current profile — Discharge-rich profile

Time increment s	Time cumulative s	Current C rate	Accumulated ΔSOC %
5	5	20	-2,778
10	15	10	-5,556
32	47	5	-10,000
20	67	0	-10,000
5	72	-15	-7,917
10	82	-10	-5,139
37	119	-5	0,000
20	139	0	0,000
5	144	15	-2,083
10	154	10	-4,861
37	191	5	-10,000
20	211	0	-10,000
5	216	-12,5	-8,264
7	223	-7,5	-6,806
35	258	-5	-1,944
42	300	0	-1,944

NOTE 1 Because of different time delays and slow rates of various battery testers which are used, no pulses shorter than 5 s are defined.

A requested C rate according to Table 18 shall be limited to the maximum current specified by the manufacturer. If so, the corresponding time increment shall be increased in order to achieve the requested  $\Delta$ SOC value. This results in an increased cumulative time for the discharge-rich profile.

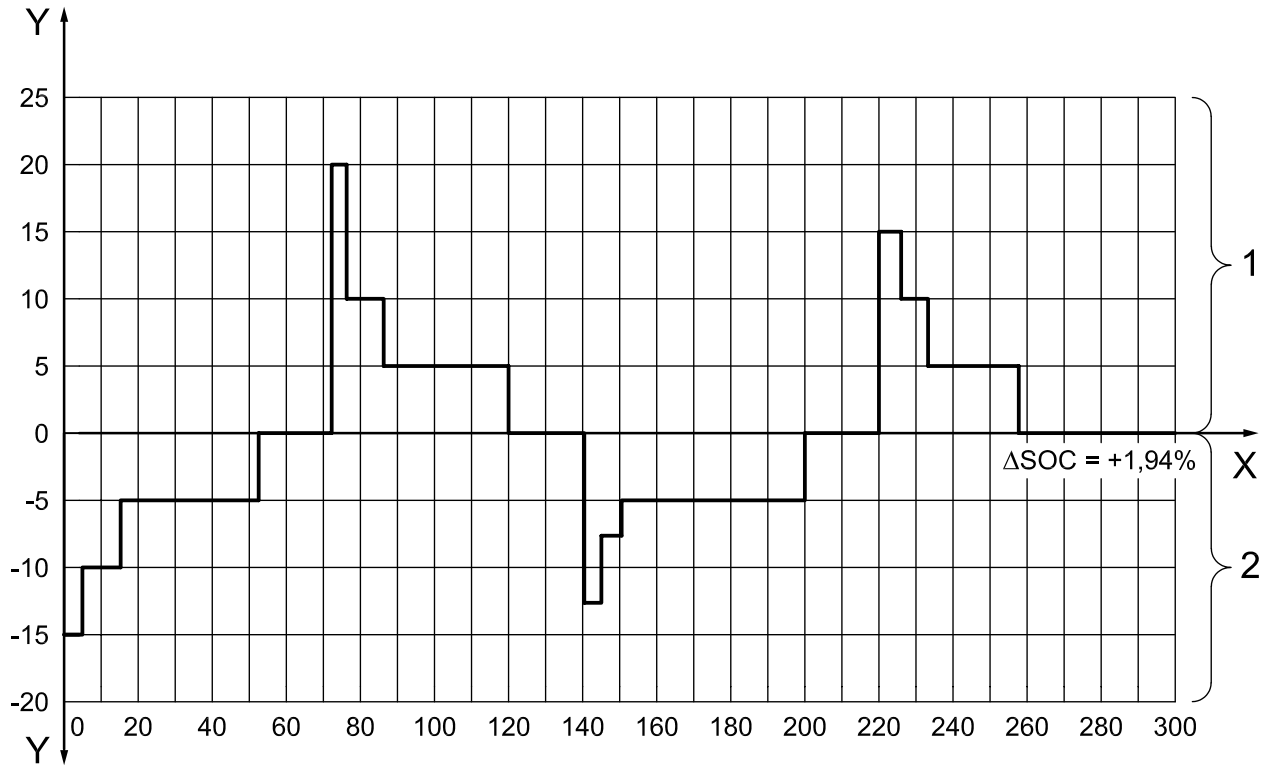

**Key**

- X time (s)
- Y current (C rate)
- 1 discharge
- 2 charge

**Figure 8 — Current profile for cycle life test — Charge-rich profile**

**Table 18 — Times and current profile — Charge-rich profile**

Time increment s	Time cumulative s	Current C rate	Accumulated $\Delta$ SOC %
5	5	-15	2,083
10	15	-10	4,861
37	52	-5	10,000
20	72	0	10,000
5	77	20	7,222
10	87	10	4,444
32	119	5	0,000
20	139	0	0,000
5	144	-12,5	1,736
7	151	-7,5	3,194
49	200	-5	10,000
20	220	0	10,000
5	226	15	7,917
10	235	10	5,139
23	258	5	1,944
42	300	0	1,944



NOTE 2 Because of different time delays and slow rates of various battery testers which are used, no pulses shorter than 5 s are defined.

A requested C rate according to Table 19 shall be limited to the maximum current specified by the manufacturer. If so, the corresponding time increment shall be increased in order to achieve the requested  $\Delta$ SOC value. This results in an increased cumulative time for the charge-rich profile.

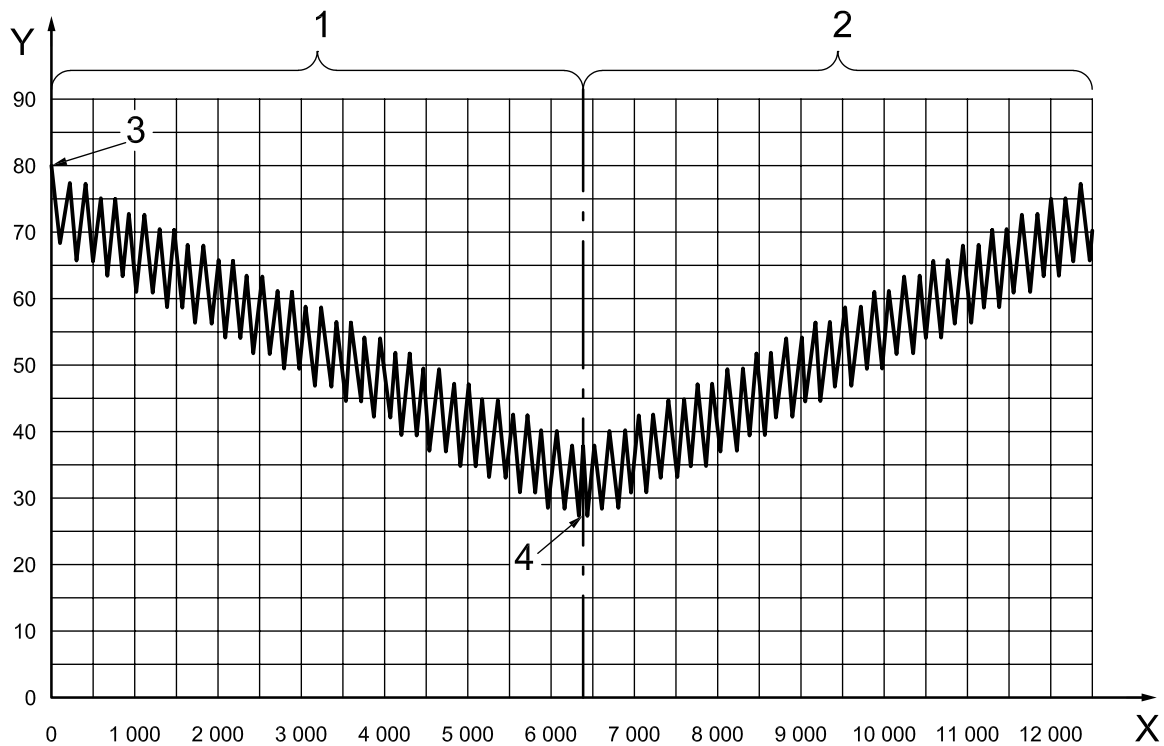

**Key**

X time (s)

Y SOC (%)

1 discharge-rich profiles

2 charge-rich profiles

3 Initial SOC = 80 %

4 cycle turning point at SOC = 30 %

NOTE At SOC = 30% is the cycle turn point.

**Figure 9 — Typical SOC swing by combination of discharge-rich and charge-rich profiles**

7.9.2.3 Test sequence cycle life test

Table 19 — Test sequence for cycle life test

Step	Procedure	Test temperature
1	Thermal equilibration	$T_{room}$
2	Standard cycle (SC)	$T_{room}$
3	Standard cycle (SC) for 1 C capacity determination	$T_{room}$
4	Standard discharge (SCH) to 80 % SOC or other upper limit SOC defined by the customer	$T_{room}$
5	Cycling by the discharge-rich profile until: <ul style="list-style-type: none"> <li>— SOC 30 % or other lower limit SOC defined by the customer;</li> <li>— battery voltage reaches lower limit defined by the supplier</li> </ul>	$T_{room}$
6	Cycling by the charge-rich profile until: <ul style="list-style-type: none"> <li>— SOC 80 % or other upper limit SOC defined by the customer;</li> <li>— battery voltage reaches upper limit defined by the supplier</li> </ul>	$T_{room}$
7	Repeat steps 5 and 6 for 22 h	$T_{room}$
8	Each day after 22 h of cycling and at the end of the charge-rich profile: <ul style="list-style-type: none"> <li>— the rest period for equilibration of cell voltages and temperature shall be agreed between the supplier and customer</li> </ul>	$T_{room}$
9	Every week after 7 days of cycling, perform power test with the following test sequence: <ul style="list-style-type: none"> <li>— thermal equilibration;</li> <li>— standard charge (SCH);</li> <li>— standard cycle (SC);</li> <li>— pulse power characterization;</li> <li>— standard charge (SCH)</li> </ul>	$T_{room}$
10	Continue with step 4, but every two weeks continue with step 2 in order to perform 1 C capacity determination	$T_{room}$

7.9.2.4 Conditions

The following apply.

- Ambient: start at  $T_{room}$  in a temperature chamber with adequate safety equipment.
- SOC range should be 30 % to 80 % or in a range agreed between the customer and supplier.
- 2 h rest period after 22 h of cycling for equilibrium and cell balancing.
- It is necessary that the designated (or comparable) battery system cooling operate.
- During cycling, the DUT electronic shall assure that no cell limits are exceeded, by achieving voltage limits as specified by the supplier. The current shall be reduced automatically to avoid any abuse operation.

### 7.9.2.5 Monitoring and data logging

All available voltage and temperature sensor data shall be monitored and logged. The amount of stored data may be reduced by logging only during selected (critical) parts of the test sequences.

Cumulated capacity which corresponds to the  $\Delta$ SOC shall be recorded in order to compare with the SOC value given by the BCU.

### 7.9.2.6 SOC determination

Due to ageing during the cycling test, a capacity loss is expected. Therefore, it is very important to provide a clear procedure to determine the SOC over the whole test period. The rated capacity, determined in 5.1 specifies the range between 100 % SOC (fully charged) and 0 % SOC (fully discharged). For adjustment of the SOC values, the 100 % value shall be taken as the basis.

### 7.9.2.7 End of test criteria

The cycle life test shall be terminated according to any of the following end-of-test criteria:

- the cycle life test profile cannot be performed any longer, for instance because limits are reached;
- the requirements of the parameter check between the life cycle test profile sequences according to Table 19 step 9 can no longer be fulfilled;
- by agreement between the supplier and customer.

### 7.9.2.8 Capacity fade

The change of dischargeable capacity from the BOL value (measured according to energy and capacity test at  $T_{\text{room}}$ ; see 7.1) to some later point in time shall be reported periodically as capacity fade. The capacity fade,  $C_{\text{fade}}$ , shall be expressed as a percentage of the initial BOL capacity (1 C at  $T_{\text{room}}$ ) as shown in Equation (2):

$$C_{\text{fade}} = 100 \times \left( 1 - \frac{C_{\text{rt,tx}}}{C_{\text{rt,t0}}} \right) \quad (2)$$

where

- $C_{\text{fade}}$  is the capacity fade, in per cent;
- $C_{\text{rt,tx}}$  is the 1 C capacity at current test;
- $C_{\text{rt,t0}}$  is the rated 1 C capacity at BOL.

### 7.9.3 Requirement

The following data shall be reported:

- initial 1 C capacity;
- internal resistances, peak power and OCV versus time from the weekly power test sequence;
- 1 C capacity versus cycling time (from bi-weekly 1C capacity determination);
- capacity fade versus cycling time.

#### 7.9.4 Calculation example for cycle life test

Concerning the energy throughput, the resulting values are the following:

- assumption: average speed of 60 km/h
- roughly calculated by “ $300 V \times I \times t$ ” and summing of all steps
- energy output each 5-min cycle: 0,36 kW·h 5 km;
- energy output each hour: 4,32 kW·h 60 km;
- energy output each day (22 h operation): 95,04 kW·h 1.320 km;
- energy output each week: 665,28 kW·h 9 240 km;
- energy output every 6 weeks: 3 991,68 kW·h 55 440 km;
- energy output every 12 weeks (1 848 h operation): 7 983,36 kW·h 110 880 km.

### 8 Reliability tests

#### 8.1 Dewing — Temperature change

##### 8.1.1 Purpose

This test simulates the use of the system/component under high ambient humidity. The failure modes addressed are electrical malfunction(s) caused by moisture (e.g. leakage current caused by a printed circuit board, which is soaked with moisture). An additional failure mode can be a breathing effect which transports moisture inside the housing when the air inside the system/components cools down and ambient air with high humidity is drawn into the system/components.

This test applies to battery packs and systems.

##### 8.1.2 Test procedure

Perform the test in accordance with IEC 60068-2-30, Db, with the following modifications:

- humidity and temperature profiles according to Figure 10;
- number of cycles: five.

Use operating mode 2.1 in accordance with ISO 16750-1 during the complete test sequence.

If the temperature of the DUT exceeds the limits given by the supplier, the DUT should be operated in an operating mode as agreed between the customer and supplier.

NOTE The temperature and humidity profile is specified to generate dewing effects approximating the vehicle environment.

##### 8.1.3 Requirement

The functional status shall be class A as specified in ISO 16750-1.

Measured data shall include isolation resistance between the DUT case and the positive and negative terminals before and after the test.

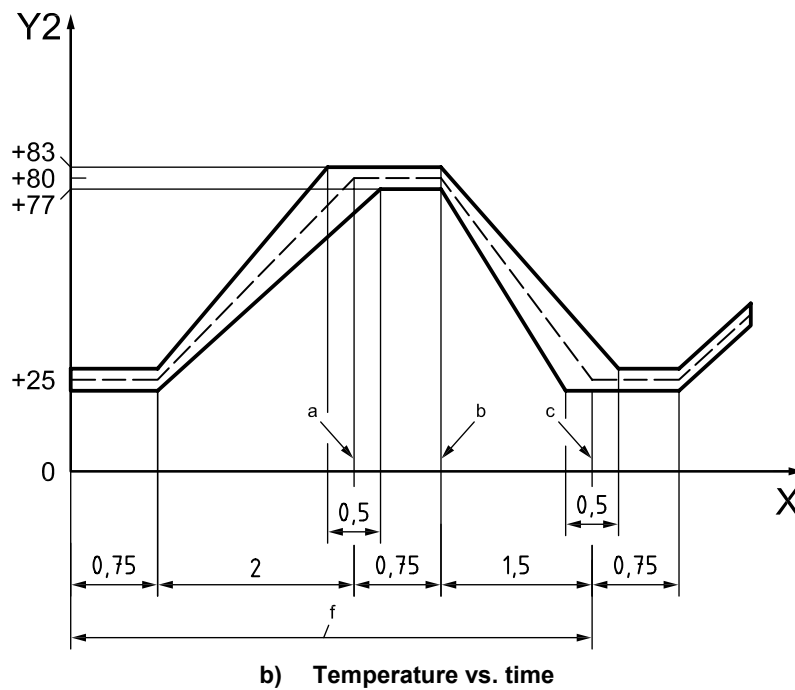
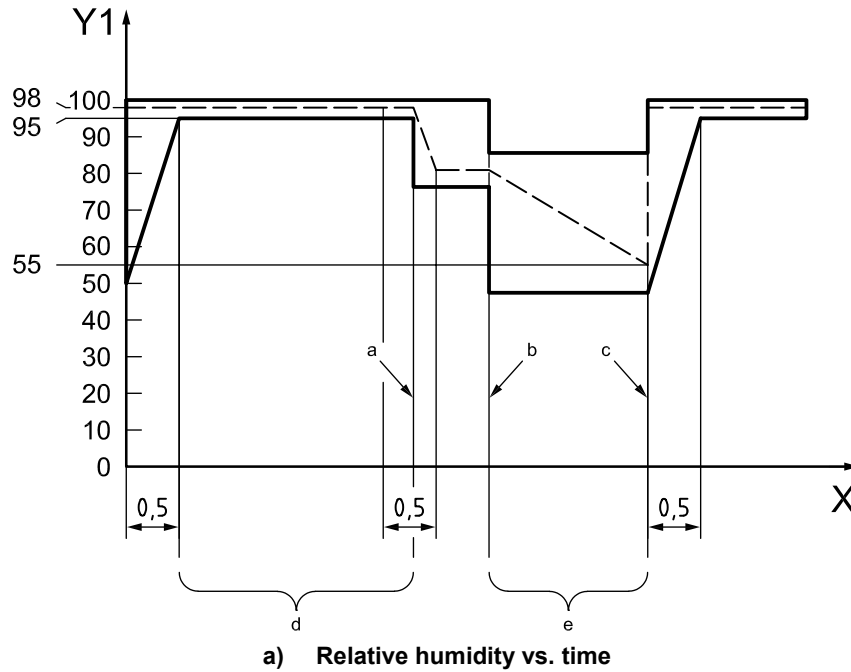

**Key**

- Y1 relative humidity (%)
- Y2' temperature (°C)
- X time, in hours
- a End of temperature rise.
- b Start of temperature fall.
- c Recommended set value humidity / temperature.
- d Condensation.
- e Drying.
- f One cycle.

**Figure 10 — Dewing cycle**

A detailed test description is given in ISO 16750-4.

## 8.2 Thermal shock cycling

### 8.2.1 Purpose

Thermal shock cycling is performed to determine the resistance of the DUT to sudden changes in temperature. The DUT undergo a specified number of temperature cycles, which start at  $T_{\text{room}}$ , followed by high- and low-temperature cycling. The failure modes addressed are electrical and mechanical malfunction(s) caused by the accelerated temperature cycling.

This test applies to battery packs and systems.

### 8.2.2 Test

Before thermal shock cycling, the DUT capacity shall be evaluated by performing two SCs according to 6.2. Adjust the SOC with a 1 C discharge to 50 % before starting the thermal shock cycling profile.

With the DUT at 50 % SOC and at  $T_{\text{room}}$ , contained in a closed volume and with all thermal controls disabled, thermally cycle the DUT with ambient temperature between 85 °C or  $T_{\text{max}}$  as specified between the supplier and customer to –40 °C (the ambient temperature should be measured in close proximity to the DUT). The time to reach each temperature extreme shall be 30 min or less. If it is logistically possible, given equipment limitations and safety considerations, the DUT can be moved between two test chambers each set at the opposite end of the temperature range. The DUT shall remain at each extreme for a minimum of 1 h. A total of five thermal cycles shall be performed. After thermal cycling, inspect the DUT for any damage, paying special attention to any seals that can exist. Verify that control circuitry is operational.

Operating mode shall be the continuous monitoring of temperatures and voltages of all available measuring points of the DUT.

After thermal shock cycling, the DUT capacity shall be evaluated by performing two SCs according to 6.2.

Measured data shall include:

- temperatures and voltages of all available measuring points of the DUT during the test;
- isolation resistance between the DUT case and the positive and negative terminals before and after the test;
- 1 C capacity at  $T_{\text{room}}$  before and after thermal shock cycling test (in each case 1 C capacity of second standard cycle).

### 8.2.3 Requirement

The functional status shall be class A as specified in ISO 16750-1.

## 8.3 Vibration

### 8.3.1 Purpose

This test checks the DUT for malfunctions and breakage caused by vibration. Vibration of the body is random vibration induced by rough-road-driving as well as internal vibration of the power train. The main failures that shall be identified by this test are breakage and loss of electrical contact.

The vibration test is composed of two parts.

- Part 1 of the vibration test procedure is intended to test the behaviour of the overall battery pack or system (see 8.3.2). Due to the big mass of this DUT, the maximum test frequency is limited to 200 Hz, but the vibration test shall be performed in sequence in all three spatial directions.

- Part 2 of the vibration test procedure is intended to test separately the behaviour of the electric and electronic devices with low masses (comparable to electric/electronic devices used in normal vehicle applications) including the mounting devices used in the battery pack or system (see 8.3.3). This test conforms to ISO 16750-3 for mounting areas on sprung masses (vehicle body).

This test applies to battery packs and systems.

NOTE This test can be performed using a battery pack subsystem (see 5.1).

### 8.3.2 Vibration test part 1 — Battery pack and system

#### 8.3.2.1 Test procedure

The test shall be performed in accordance with IEC 60068-2-64:2008, Tables 20 to 23, or according to a test profile determined by the customer and verified to the vehicle application.

The given test parameters are valid for DUT designed for mounting on sprung masses (vehicle body) of a vehicle. The DUT shall be mounted on a shaker test bench according to the designed vehicle mounting position and according to the requirements given in IEC 60068-2-47.

The vibration test shall be performed in a sequence of all three spatial directions, if not otherwise agreed between the customer and supplier, starting with the vertical direction (Z), followed by the transverse direction (Y) and, finally, with the longitudinal direction (X).

The mechanical stresses acting on the DUT are specified by a stochastic acceleration: time function with a test duration per spatial direction of 21 h. The test duration per spatial direction may be reduced to 15 h if the test procedure is performed with two identical DUT, or to 12 h if the test procedure is performed with three identical DUT. For this, one test spectrum between 5 Hz and 200 Hz is defined for each spatial direction as the desired PSD for the vibration controller (PSD\_vertical\_Z, PSD\_horizontal\_transverse\_Y, PSD\_horizontal\_longitudinal\_X). If the DUT is designed for a vehicle mounting position below the vehicle passenger compartment, the reduced spectrum PSD\_horizontal\_transverse\_Y<sub>Passenger\_compartment\_bottom</sub> according to Table 22 shall be used. In case of any doubt, the supplier and customer shall agree which transverse Y profile shall apply.

**Table 20 — Values for PSD\_horizontal\_longitudinal\_X**

Frequency Hz	PSD g <sup>2</sup> /Hz	PSD (m/s <sup>2</sup> ) <sup>2</sup> /Hz
5	0,0125	1,20
10	0,03	2,89
20	0,03	2,89
200	0,000 25	0,02
r.m.s	0,96 g	9,42 m/s <sup>2</sup>

**Table 21 — Values for PSD\_horizontal\_transvers\_Y**

Frequency Hz	PSD g <sup>2</sup> /Hz	PSD (m/s <sup>2</sup> ) <sup>2</sup> /Hz
5	0,04	3,85
20	0,04	3,85
200	0,000 8	0,08
r.m.s	1,23 g	12,07 m/s <sup>2</sup>

Table 22 — Values for PSD\_horizontal\_transvers\_Y<sub>Passenger\_compartment\_bottom</sub>

Frequency Hz	PSD g <sup>2</sup> /Hz	PSD (m/s <sup>2</sup> ) <sup>2</sup> /Hz
5	0,01	0,96
10	0,015	1,44
20	0,015	1,44
50	0,01	0,96
200	0,000 4	0,04
r.m.s	0,95 g	9,32 m/s <sup>2</sup>

Table 23 — Values for PSD\_vertical\_Z

Frequency Hz	PSD g <sup>2</sup> /Hz	PSD (m/s <sup>2</sup> ) <sup>2</sup> /Hz
5	0,05	4,81
10	0,06	5,77
20	0,06	5,77
200	0,000 8	0,08
r.m.s	1,44 g	14,13 m/s <sup>2</sup>

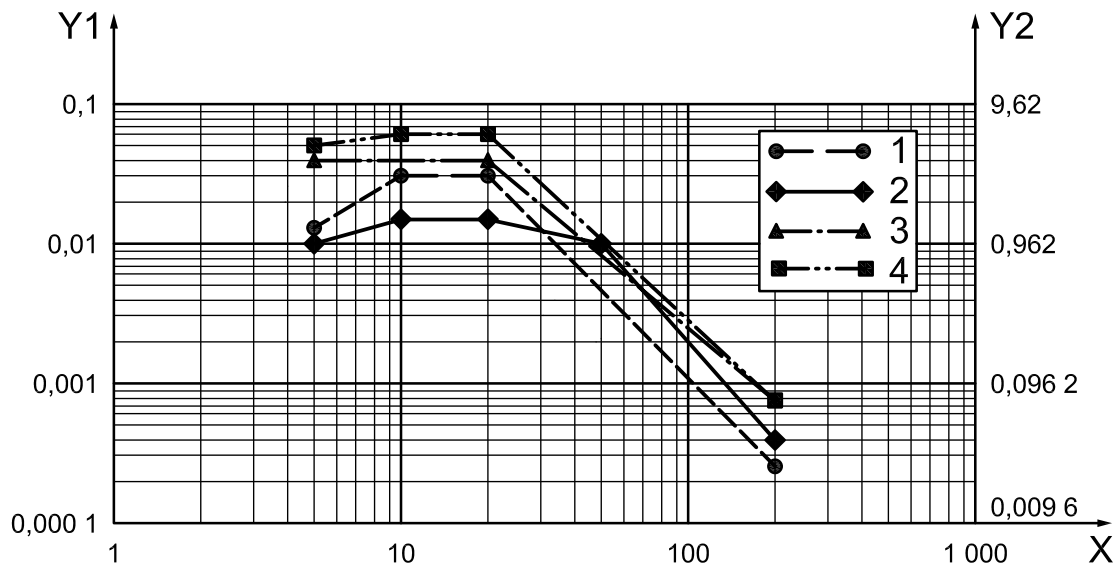

**Key**

- X frequency (Hz)
- Y1 power density (g<sup>2</sup>/Hz)
- Y2 power density (PSD) (m/s<sup>2</sup>)<sup>2</sup>/Hz
- 1 PSD horizontal longitudinal X
- 2 PSD horizontal transverse Y
- 3 PSD horizontal transverse Y
- 4 PSD vertical Z

NOTE Masses are mounted on the vehicle body.

Figure 11 — PSD spectra for sprung masses



The following control parameters shall be ensured:

- delta frequency  $1,25 \pm 0,25$  Hz
- inner range of tolerance  $\pm 3$  dB  
(warning level)
- outer range of tolerance  $\pm 6$  dB  
(shut-down level)

It shall be assumed that the battery pack or system design is especially affected by temperatures over its lifetime; therefore, the vibration testing (test time for each spatial direction) of the battery pack or system shall be superimposed by a temperature profile according to Table 24:

**Table 24 — Values for test duration and ambient temperature**

One test sample time min	Two test samples time min	Three test samples time min	Test temperature
0	0	0	$T_{\text{room}}$
105	75	60	$T_{\text{min}}$
420	300	240	$T_{\text{min}}$
525	375	300	$T_{\text{room}}$
700	500	400	$T_{\text{max}}$
1 085	775	620	$T_{\text{max}}$
1 260	900	720	$T_{\text{room}}$
$\Sigma = 21$ h	$\Sigma = 15$ h	$\Sigma = 12$ h	

$T_{\text{min}}$  and  $T_{\text{max}}$  shall be agreed between the battery pack or system supplier and customer. If not defined, the following values shall be used:  $T_{\text{min}} = -40$  °C;  $T_{\text{max}} = 75$  °C

Before vibration testing, the DUT capacity shall be evaluated by performing two SCs according to 6.2. Adjust the SOC with a 1 C discharge to 50 % before starting the vibration test profile.

After vibration testing, the DUT capacity shall be evaluated by performing two SCs according to 6.2.

### 8.3.2.2 Requirements

Breakage and loss of electrical contact shall not occur according to the requirements of the vibration test procedure.

Operating mode shall be with the main contactors closed.

Functional status class A (see ISO 16750-1) shall be required during operating mode 3.2 as specified in ISO 16750-1, and functional status class C during periods with other operating modes.

Measured data shall include:

- voltage across the positive and negative terminals of the DUT during the test;
- isolation resistance between the DUT case and the positive and negative terminals before and after the test;
- 1 C capacity at  $T_{\text{room}}$  before and after the test (in each case 1 C capacity of second SC).

8.3.3 Vibration test part 2 — Electric/electronic devices of battery pack and system

8.3.3.1 Test procedure

The given test parameters are valid for DUT designed for mounting on sprung masses (vehicle body) of a vehicle. If the specific requirement of the vehicle or the mounting area differs from those requirements given in the following test procedure, the test shall be performed in accordance with ISO 16750-3 or according to data from specific operating load measurements on a vehicle.

Perform the test for random vibration in accordance with IEC 60068-2-64. Use the test duration of 8 h for each plane of the DUT.

The r.m.s acceleration value shall be 27,8 m/s<sup>2</sup>.

For the PSD vs. frequency, see Figure 12 and Table 25.

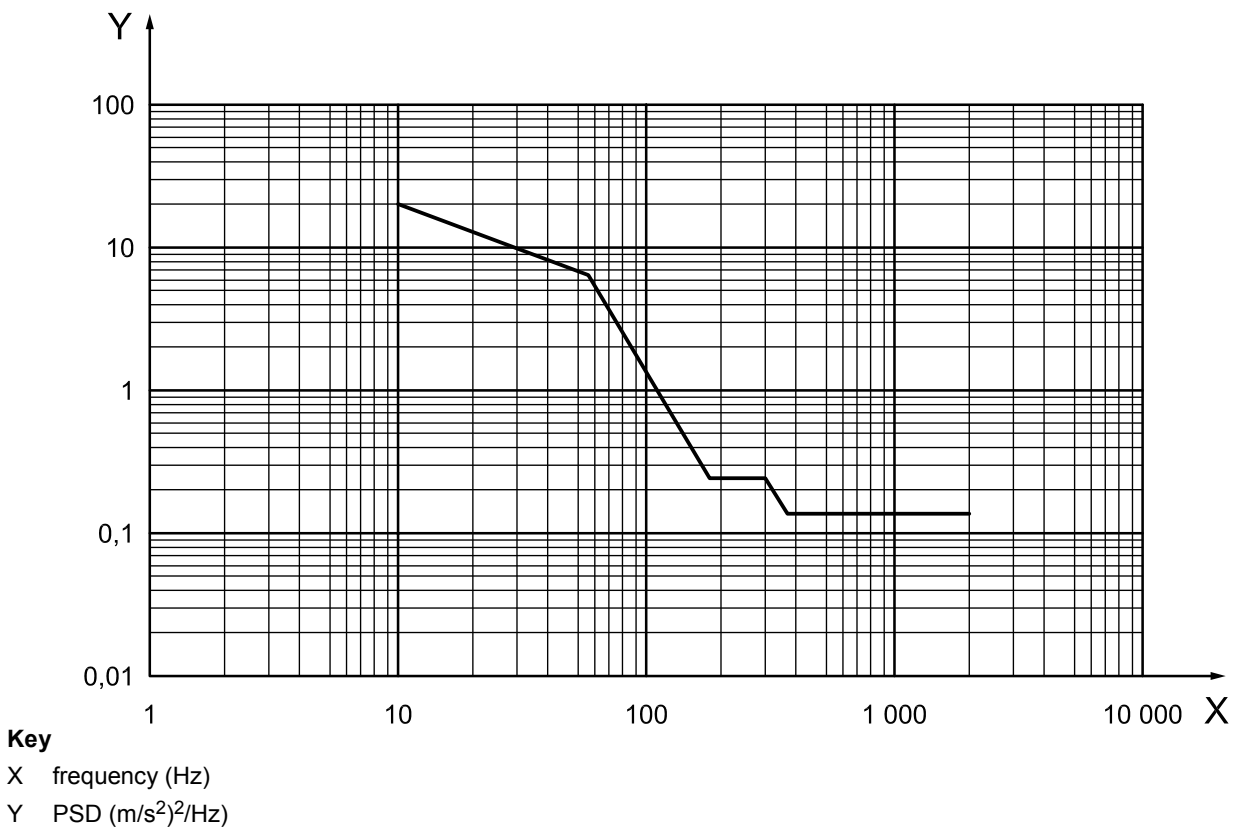

Figure 12 — PSD of acceleration vs. frequency

Table 25 — Values for PSD and frequency

Frequency Hz	PSD (m/s <sup>2</sup> ) <sup>2</sup> /Hz
10	20
55	6,5
180	0,25
300	0,25
360	0,14
1 000	0,14
2 000	0,14

### 8.3.3.2 Requirement

Breakage and loss of electrical contact shall not occur according to the requirements of the vibration test procedure.

Functional status class A (see ISO 16750-1) is required during operating mode 3.2 as specified in ISO 16750-1, and functional status class C during periods with other operating modes.

## 8.4 Mechanical shock

### 8.4.1 Purpose

This test is applicable to packs and systems intended to be mounted at rigid points of the body or on the frame of a vehicle.

The load occurs, for example when driving over a curb stone at high speed. Failure mode is a mechanical damage of components due to the resulting high accelerations.

This test applies to battery packs and systems.

NOTE This test can be performed using a battery pack subsystem (see 5.1).

### 8.4.2 Test

The test shall be performed in accordance with ISO 16750-3, Table 26 (below) or according to a test profile determined by the customer and verified to the vehicle application.

Acceleration from the shock in the test shall be applied in the same direction as the acceleration of the shock that occurs in the vehicle. If the direction of the effect is not known, the DUT shall be tested in all six spatial directions.

**Table 26 — Mechanical shock test — Parameters**

Procedure	Requirement
Operating mode of DUT (see ISO 16750-1)	mode 3.2
Pulse shape	half-sinusoidal
Acceleration	500 m/s <sup>2</sup>
Duration	6 ms
Temperature	$T_{\text{room}}$
Number of shocks	10 per test direction

Before mechanical shock testing, the DUT capacity shall be evaluated by performing two SCs according to 6.2. Adjust the SOC with a 1 C discharge to 50 % before starting the mechanical shock profile.

Operating mode shall be the continuous monitoring of temperatures and voltages of all available measuring points of the DUT.

After mechanical shock testing, the DUT capacity shall be evaluated by performing two SCs according to 6.2.

### 8.4.3 Requirement

The functional status shall be class A as specified in ISO 16750-1.

Measured data shall include:

- temperatures and voltages of all available measuring points of the DUT during the test;
- isolation resistance between the DUT case and the positive and negative terminals before and after the test;
- 1 C capacity at  $T_{\text{room}}$  before and after the test (in each case, 1 C capacity of the second SC).

## 9 Abuse tests

### 9.1 Information

#### 9.1.1 State of charge

Although a high-power battery pack or system may be considered fully charged at 80 % SOC, abuse tests shall be conducted at 100 % SOC, unless specifically stated otherwise.

#### 9.1.2 Conditioning

Unless specifically stated otherwise, the following conditions should apply.

- The test should be conducted at  $T_{\text{room}}$ .
- The DUT should be at its normal operating temperature.
- If the battery system includes thermal control systems, they should be operational.
- If cooling media are necessary for operation, they should be in place.

#### 9.1.3 Test duration

After each test, the DUT shall be observed for a time period of at least 1 h and until the DUT temperature is below 50 °C or until such time that the DUT is deemed safe to handle.

## 9.2 Short-circuit protection

### 9.2.1 Purpose

The purpose of the short-circuit protection test is to check the functionality of the overcurrent protection device. This device shall interrupt the short-circuit current in order to prevent the DUT from further related severe events caused by a short-circuit current.

This test applies to battery packs and systems.

### 9.2.2 Test procedure

The DUT shall be at  $T_{\text{room}}$ , fully charged and under normal operating conditions (main contactors are closed, battery systems are controlled by the BCU). An appropriately sized conductor of  $\left(100 \begin{smallmatrix} +0 \\ -40 \end{smallmatrix}\right)$  m $\Omega$  shall be used to apply a “hard short” in less than 1 s for 10 min, or until another condition occurs that prevents completion of the test (e.g. component melting). The test shall be performed with integrated passive and non-passive short-circuit protection devices operational.

After the DUT has been shorted as described above, the observation of the DUT shall be continued for 2 h.

All functions of the DUT shall be fully operational as designed during the test. At pack level, the overcurrent protecting device (e.g. fuse) shall interrupt the short-circuit current. At system level, the short-circuit current shall be interrupted by the overcurrent protecting device (e.g. fuse) and/or by an automatic disconnect by the main contactors.

Data sampling, especially for DUT voltage and current, shall be performed with an adequate sampling rate, e.g. 0,1 ms, for evaluation of the current shut-off function and the real short-circuit current peak.

### 9.2.3 Requirements

Measured data shall include:

- DUT voltage, current and temperature as a function of time;
- isolation resistance between the DUT case and the positive and negative terminals before and after the test.

## 9.3 Overcharge protection

### 9.3.1 Purpose

The purpose of the overcharge protection test is to check the functionality of the overcharge protection function. This function shall interrupt the overcharge current in order to protect the DUT from any further related severe events caused by an overcharge current.

This test applies to battery systems only.

### 9.3.2 Test procedure

The DUT shall be at  $T_{room}$ , fully charged and under normal operating conditions with the cooling system operating (main contactors are closed, battery system is controlled by the BCU). The test shall be performed with integrated passive circuit protection devices operational. Active charge control of the test equipment shall be disconnected.

- The DUT shall be charged at a constant current rate which is agreed by the supplier and customer. The recommended constant charge current should be 5 C.
- The upper limit for the power-supply voltage should be set not to exceed 20 % of the maximum battery system voltage.
- Charging shall be continued until the DUT interrupts the charging by an automatic disconnect of the main contactors.
- The overcharge test shall be terminated if the SOC level is above 130 % or cell temperature levels are above 55 °C. Limits for SOC and DUT cell temperature levels for terminating the overcharge protection test may be agreed between the supplier and customer.

Data acquisition/monitoring shall be continued for 1 h after charging is stopped.

All functions of the DUT shall be fully operational as designed during the test. The BCU shall interrupt the overcharge current by an automatic disconnect of the main contactors in order to protect the DUT from further related severe effects.

Data sampling, especially for DUT voltage and current, shall be performed with an adequate sampling rate, e.g. 100 ms, for evaluation of the current shut-off function.

### 9.3.3 Requirement

Measured data shall include:

- DUT voltage, current and temperature as a function of time;
- isolation resistance between the DUT case and the positive and negative terminals before and after the test.

## 9.4 Overdischarge protection

### 9.4.1 Purpose

The purpose of the overdischarge protection test is to check the functionality of the overdischarge protection function. This device shall interrupt the overdischarge current in order to protect the DUT from any further related severe events caused by an overdischarge current.

This test applies to battery systems only.

### 9.4.2 Test procedure

The DUT shall be at  $T_{room}$ , fully charged and under normal operating conditions with the cooling system operating (main contactors are closed, battery system is controlled by the BCU). The test shall be performed with integrated passive circuit protection devices operational. Active discharge control of the test equipment shall be disconnected.

- Perform a standard discharge. If the normal discharge limits are reached, discharging with 1 C rate shall be continued.
- Discharging shall be continued until the DUT interrupts the discharging by an automatic disconnect of the main contactors.
- The discharge test shall be terminated manually if 25 % of the nominal voltage level or a time limit of 30 min after passing the normal discharge limits of the DUT have been achieved. Values for time and voltage limits for terminating the overdischarge protection test may be agreed between the supplier and customer.

NOTE Nominal voltage is the voltage given by the supplier as the recommended operating voltage of their battery system. Voltage depends on chemistry, cell numbers and arrangement of cells.

Data acquisition/monitoring shall be continued for 1 h after discharging is stopped.

All functions of the DUT shall be fully operational as designed during the test. The BCU shall interrupt the overdischarge current by an automatic disconnect of the main contactors in order to protect the DUT against further related severe effects.

Data sampling, especially at normal discharge limits and beyond for DUT voltage and current, shall be performed with an adequate sampling rate, e.g. 100 ms, for evaluation of the current shut-off function.

### 9.4.3 Requirements

Measured data shall include:

- DUT voltage, current and temperature as a function of time;
- isolation resistance between the DUT case and the positive and negative terminals before and after the test.

## Annex A (informative)

### Battery pack and system and overview on tests

#### A.1 General

This annex provides information on how to distinguish between a battery pack and a battery system. It recommends assignments of tests to battery packs and systems.

#### A.2 Battery pack

Figure A.1 shows a typical configuration of a battery pack.

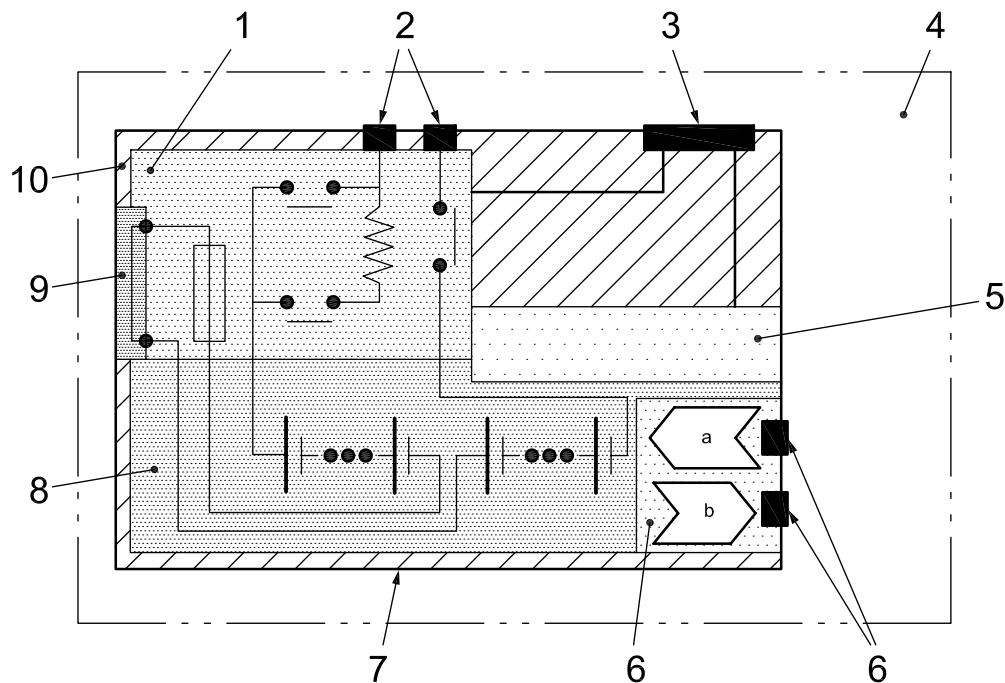

#### Key

- 1 voltage class B electric circuit (connectors, fuses, wiring)
- 2 voltage class B connections
- 3 voltage class A connections
- 4 battery pack
- 5 cell electronics
- 6 cooling device and connections (optional)
- 7 normal use impact-resistant case
- 8 cell assembly (cells, sensors, cooling equipment)
- 9 service disconnect
- 10 bus
- a In.
- b Out.

Figure A.1 — Typical configuration of a battery pack

A battery pack represents an energy storage device, which includes cells or cell assemblies, cell electronics, voltage class B circuit and overcurrent shut-off device, including electrical interconnections, interfaces for cooling, voltage class B, auxiliary voltage class A and communication. The voltage class B circuit of the battery pack may include contactors and a manual shut-off function (service disconnect). All components are typically placed in a normal use impact-resistant case.

### A.3 Battery system

#### A.3.1 Battery system with integrated BCU

Figure A.2 shows a typical configuration of a battery system with integrated BCU.

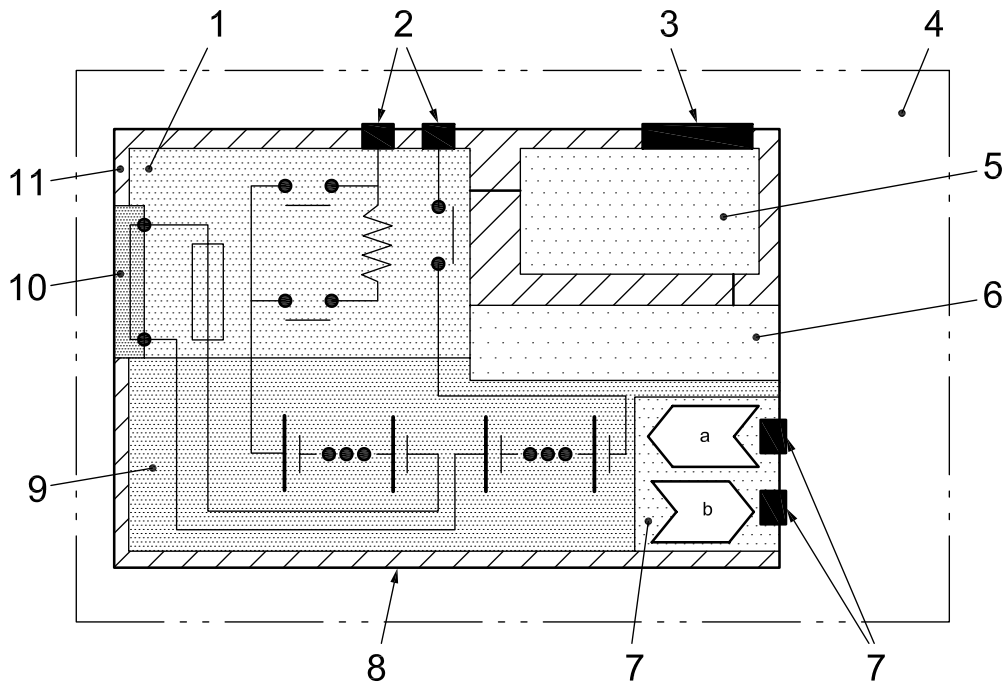

**Key**

- 1 voltage class B electric circuit (connectors, fuses, wiring)
  - 2 voltage class B connections
  - 3 voltage class A connections
  - 4 battery system
  - 5 BCU
  - 6 cell electronics
  - 7 cooling device and connections (optional)
  - 8 normal use impact-resistant case
  - 9 cell assembly (cells, sensors, cooling equipment)
  - 10 service disconnect
  - 11 bus
- a In.  
b Out.

**Figure A.2 — Typical configuration of a battery system with integrated BCU**



A battery system represents an energy storage device that includes cells or cell assemblies, cell electronics, a BCU, voltage class B circuit with contactors and overcurrent shut-off device, including electrical interconnections, interfaces for cooling, voltage class B, auxiliary voltage class A and communication. The voltage class B circuit may include a manual shut-off function (service disconnect). All components are typically placed in a normal use impact-resistant case. In this example, the BCU is integrated into the normal use impact-resistant case and connected via its control functionalities to the battery pack.

### A.3.2 Battery system with external BCU

Figure A.3 shows the typical configuration of a battery system with external BCU.

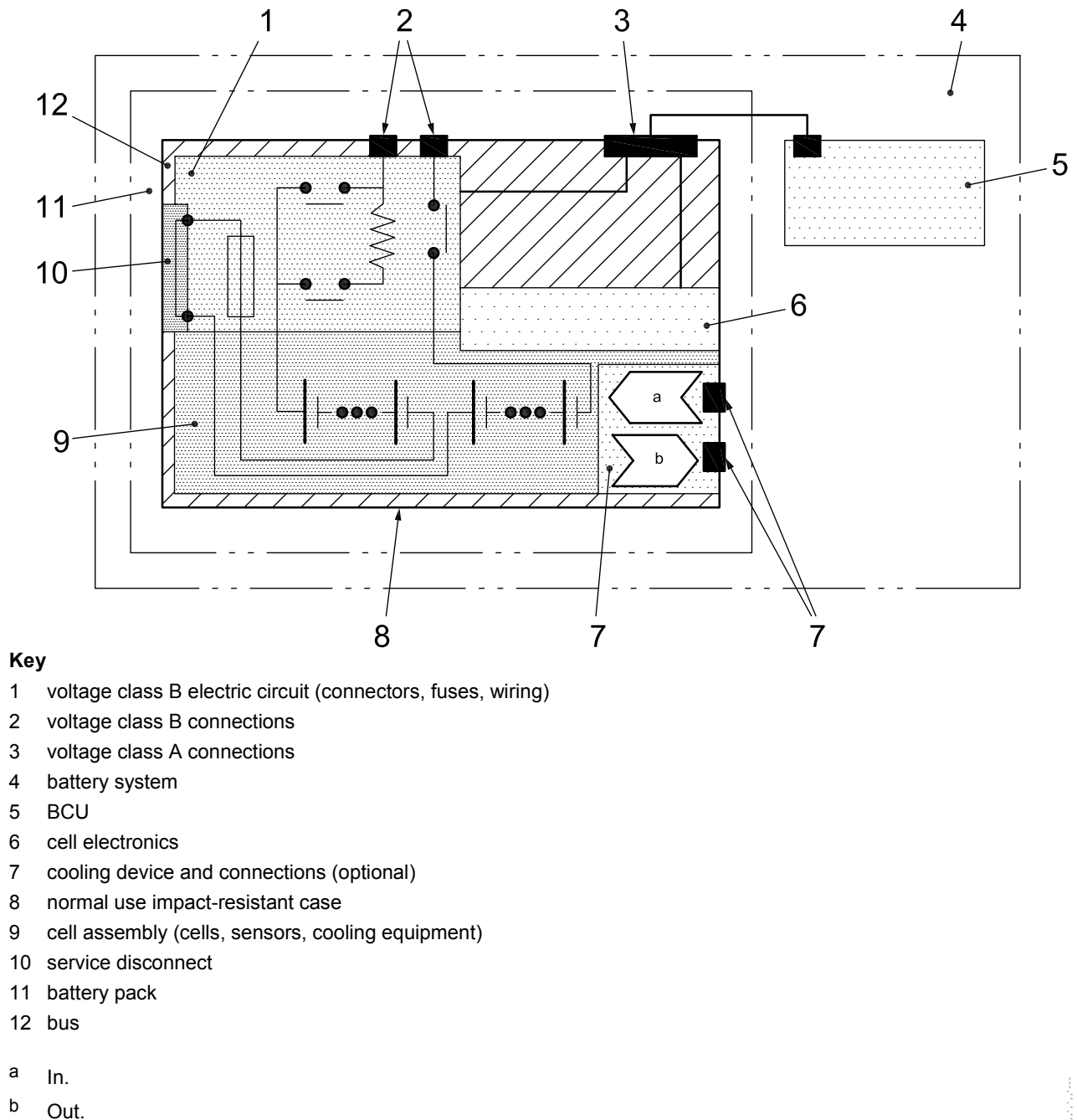

**Figure A.3 — Typical configuration of a battery system with external BCU**

A battery system represents an energy storage device that includes cells or cell assemblies, cell electronics, a BCU, voltage class B circuit with contactors and overcurrent shut-off device, including electrical interconnections, interfaces for cooling, voltage class B, auxiliary voltage class A and communication. The voltage class B circuit may include a manual shut-off function (service disconnect). All components are typically placed in a normal use impact-resistant case. In this example, the BCU is placed outside the normal use impact-resistant case and connected via its control functionalities to the battery pack.

### A.4 Overview on tests

Table A.1 recommends which tests should be carried out on which level.

**Table A.1 — Assignment of tests to battery pack and system**

Test procedure	Performance								Reliability				Abuse		
	Energy and capacity	Power and internal resistance	No-load SOC loss	SOC loss at storage	Cranking power at low temperatures	Cranking power at high temperatures	Energy efficiency	Cycle life	Dewing	Thermal shock cycling	Vibration	Mechanical shock	Short circuit	Overcharge protection	Overdischarge protection
<b>Battery system (battery pack with integrated BCU)</b>															
System	X	X	X	X	X	X	X	X	X	X	X	X	V	V	V
<b>Battery system (battery pack with external BCU)</b>															
System	X	X	X	X	X	X	X	X	—	—	—	—	V	V	V
Pack <sup>a</sup>	U	U	—	—	—	—	—	—	X	X	X	X	W	—	—
X relevant test — test not relevant U adapted/reduced procedure V functional test including active BCU W fuse test															
<sup>a</sup> BCU not included, external BCU not operating, cooling not operating, main contactors controlled manually															

## Annex B (informative)

### Examples of data sheet for battery pack and system testing

Tables B.1 to B.5 can be taken as examples for reporting the test results. They should be filled in by the test institute and included in the test report. In addition, diagrams of capacity versus constant current discharge (at different ambient temperatures) and power versus constant power discharge (at different ambient temperatures) can also be included in the test report. The battery supplier should provide all the necessary information and technical data to support the test itself.

**Table B.1 — Battery pack/system — General supplier data**

<b>Supplier</b>	
Company	
Address	
Internet address	
<b>Contact person</b>	
Name	
Tel.	
E-mail	
Fax	

**Table B.2 — Battery pack/system**

Type of chemistry			
Manufacturer's trade name			
Date of manufacturing			
Nominal pack/system voltage [V]			
Nominal capacity @ 1 C [A·h]			
Nominal cell voltage [V]			
Number of cells			
Number of cell assemblies			
Type of cathode material			
Type of anode material			
Type of separator material			
Type of electrolyte			
	Cell:	Cell assembly (module):	Pack/system:
Mass [kg]			
Volume [dm <sup>3</sup> ]			
Length [mm]			
Width [mm]			
Height [mm]			
<b>Date battery pack/system received by customer [YYYY-MM-DD]:</b>			
<b>Peripherals and instruction</b>			
BCU	Yes:	No:	
Thermal management	Yes:	No:	
Safety devices	Yes:	No:	
Operating manual	Yes:	No:	

**Table B.3 — Battery pack/ system — Auxiliary equipment**

	BCU	Cooling	Connectors	Other	Tray	Total
Mass [kg]						
Volume [dm <sup>3</sup> ]						
Length [mm]						
Width [mm]						
Height [mm]						
Power consumption [W]						

Table B.4 — Battery pack/system — Operating conditions

Charging	
Method	
Charging time	
Temperature limits [°C]	min:                      max:
Max. continuous charge current [A]	
Max. charge current [A], duration [s]	
Max. battery temperature during charge [°C]	
Max. voltage during charge [V]	
Full description of the charging procedure including a charge diagram shall be given in an appendix/annex.	
Discharging	
Temperature limit [°C]	min:                      max:
Max. continuous discharge current [A]	
Max. discharge current [A], duration [s]	
Min. voltage during discharge [V]	
Cut-off voltage [V]	
Full description of the requirements for current and voltage limits depending on SOC and temperature during discharging shall be given in an appendix/annex.	

Table B.5 — Battery pack/system — Performance characteristics

Test temperature [°C]					
Capacity [A·h]	1 C:	2 C:	10 C:	C at $I_{d,max}$ :	
Energy [W·h]	1 C:	2 C:	10 C:	C at $I_{d,max}$ :	
Specific energy [W·h/kg]	1 C:	2 C:	10 C:	C at $I_{d,max}$ :	
Energy density [W·h/l]	1 C:	2 C:	10 C:	C at $I_{d,max}$ :	
	80 % SOC:	65 % SOC:	50 % SOC:	35 % SOC:	20 % SOC:
0,1 s discharge resistance [mΩ]					
2 s discharge resistance [mΩ]					
10 s discharge resistance [mΩ]					
18 s discharge resistance [mΩ]					
0,1 s discharge power [W]					
2 s discharge power [W]					
10 s discharge power [W]					
18 s discharge power [W]					
0,1 s charge resistance [mΩ]					
2 s charge resistance [mΩ]					
10 s charge resistance [mΩ]					
0,1 s regenerative power [W]					
2 s regenerative power [W]					
10 s regenerative power [W]					
Open-circuit voltage [V]					

## Annex C (informative)

### Example of test conditions

As described in the Scope, relevant test procedures and test conditions may be selected from this part of ISO 12405 based on the agreement between the customer and supplier.

This annex provides the users of this part of ISO 12405 with an example of test conditions; see Table C.1.

**Table C.1 — Example of a list of test conditions**

Test	Condition	
7.1 Energy and capacity at $T_{room}$	Discharge rate	1C, 10C
7.3 Power and internal resistance	Temperature	40 °C, $T_{room}$ , 0 °C at 50 % SOC
	SOC	80 %, 50 %, 20 % at $T_{room}$
7.4 No-load SOC loss	Temperature	$T_{room}$
7.5 SOC loss at storage	All conditions specified in 7.5	
7.6 Cranking power at low temperature	Temperature	-18 °C
7.7 Cranking power at high temperature	All conditions specified in 7.7	
7.8 Energy efficiency	Temperature	$T_{room}$ , 40 °C, 0 °C at 50 % SOC
	SOC	80 %, 50 %, 20 % at $T_{room}$
	Discharge rate	$I_{d,max}$
	Charge rate	-0,75 $I_{d,max}$
7.9 Life cycle	End of test criteria	As specified in 7.9.2.7, or after 3 months
8.1 Dewing — temperature change	All conditions specified in 8.1	
8.2 Thermal shock cycling	All conditions specified in 8.2	
8.3 Vibration	Temperature	$T_{room}$
8.4 Mechanical shock	All conditions specified in 8.4	
9.2 Short-circuit protection	All conditions specified in 9.2	
9.3 Overcharge protection	All conditions specified in 9.3	
9.4 Overdischarge protection	All conditions specified in 9.4	

## Bibliography

- [1] IEC 62660-1, *Secondary lithium-ion cells for the propulsion of electric road vehicles — Part 1: Performance testing*
- [2] IEC 62660-2, *Secondary lithium-ion cells for the propulsion of electric road vehicles — Part 2: Reliability and abuse testing*
- [3] SAE J2464: Electric and Hybrid Vehicle Rechargeable Energy Storage System (RESS) Safety and Abuse Testing, November 2009
- [4] EUCAR (European Council for Automotive Research): Specification of Test Procedures for Safety Testing of Traction Batteries; Traction Battery Working Group, March 2003
- [5] EUCAR (European Council for Automotive Research): Specification of test procedures for high voltage hybrid electric vehicle traction batteries; Traction Battery Working Group, Draft April 2004
- [6] FreedomCAR: Battery Test Manual for power-assist Hybrid Electric Vehicles, October 2003
- [7] FreedomCAR: Battery technology life verification test manual, February 2005
- [8] FreedomCAR: Electrical energy storage system — Abuse test manual for electric and hybrid electric vehicle applications; June 2005
- [9] USABC (United States Advanced Battery Consortium): Development of advanced high power batteries for hybrid electric vehicle applications
- [10] USABC (United States Advanced Battery Consortium): Electrochemical storage system — Abuse test procedure manual
- [11] System design requirements specification (VDA Initiative Circle “Energy Storage System”, Source: VDA)



.....

---

---

**ICS 43.120**

Price based on 58 pages