

---

---

**Commercial road vehicles — Drawbar  
couplings and eyes for rigid drawbars —**

**Part 2:**

**Strength tests for special applications**

*Véhicules routiers commerciaux — Pivot et anneaux pour barres  
d'attelage rigides —*

*Partie 2: Essais de résistance pour applications spéciales*



Reference number  
ISO 12357-2:2007(E)

© ISO 2007

**PDF disclaimer**

This PDF file may contain embedded typefaces. In accordance with Adobe's licensing policy, this file may be printed or viewed but shall not be edited unless the typefaces which are embedded are licensed to and installed on the computer performing the editing. In downloading this file, parties accept therein the responsibility of not infringing Adobe's licensing policy. The ISO Central Secretariat accepts no liability in this area.

Adobe is a trademark of Adobe Systems Incorporated.

Details of the software products used to create this PDF file can be found in the General Info relative to the file; the PDF-creation parameters were optimized for printing. Every care has been taken to ensure that the file is suitable for use by ISO member bodies. In the unlikely event that a problem relating to it is found, please inform the Central Secretariat at the address given below.



**COPYRIGHT PROTECTED DOCUMENT**

© ISO 2007

All rights reserved. Unless otherwise specified, no part of this publication may be reproduced or utilized in any form or by any means, electronic or mechanical, including photocopying and microfilm, without permission in writing from either ISO at the address below or ISO's member body in the country of the requester.

ISO copyright office  
Case postale 56 • CH-1211 Geneva 20  
Tel. + 41 22 749 01 11  
Fax + 41 22 749 09 47  
E-mail [copyright@iso.org](mailto:copyright@iso.org)  
Web [www.iso.org](http://www.iso.org)

Published in Switzerland

## Foreword

ISO (the International Organization for Standardization) is a worldwide federation of national standards bodies (ISO member bodies). The work of preparing International Standards is normally carried out through ISO technical committees. Each member body interested in a subject for which a technical committee has been established has the right to be represented on that committee. International organizations, governmental and non-governmental, in liaison with ISO, also take part in the work. ISO collaborates closely with the International Electrotechnical Commission (IEC) on all matters of electrotechnical standardization.

International Standards are drafted in accordance with the rules given in the ISO/IEC Directives, Part 2.

The main task of technical committees is to prepare International Standards. Draft International Standards adopted by the technical committees are circulated to the member bodies for voting. Publication as an International Standard requires approval by at least 75 % of the member bodies casting a vote.

Attention is drawn to the possibility that some of the elements of this document may be the subject of patent rights. ISO shall not be held responsible for identifying any or all such patent rights.

ISO 12357-2 was prepared by Technical Committee ISO/TC 22, *Road vehicles*, Subcommittee SC 15, *Interchangeability of components of commercial vehicles and buses*.

ISO 12357 consists of the following parts, under the general title *Commercial road vehicles — Drawbar couplings and eyes for rigid drawbars*:

- *Part 1: Strength tests for general cargo centre-axle trailers*
- *Part 2: Strength tests for special applications*



# Commercial road vehicles — Drawbar couplings and eyes for rigid drawbars —

## Part 2: Strength tests for special applications

### 1 Scope

This International Standard lays down test conditions and strength requirements to be met by:

a) Case A (see Figure 1 a): Drawbar couplings and corresponding drawbar eyes for rigid drawbars which are provided for use on rigid drawbar trailers (see 3.2) with a maximum design total mass,  $C+S$ , exceeding 3,5 tonnes and:

- a vertical static load  $S$  (see 3.1) exceeding 10 % of their design total mass, and/or
- a vertical static load  $S$  greater than 1 000 kg and up to 2 000 kg.

**EXAMPLE** Examples of couplings and corresponding drawbar eyes include drawbar couplings according to ISO 3584 combined with drawbar eyes according to ISO 1102.

**NOTE** This International Standard does not apply if both values, 10 % and 1 000 kg, are not exceeded. Such towed vehicles are defined as centre-axle trailers and are subject to ISO 12357-1.

b) Case B (see Figure 1 b): Drawbar couplings and corresponding drawbar eyes for use on vehicle transport combinations, provided for a technical mass  $C$  exceeding 3,5 tonnes.

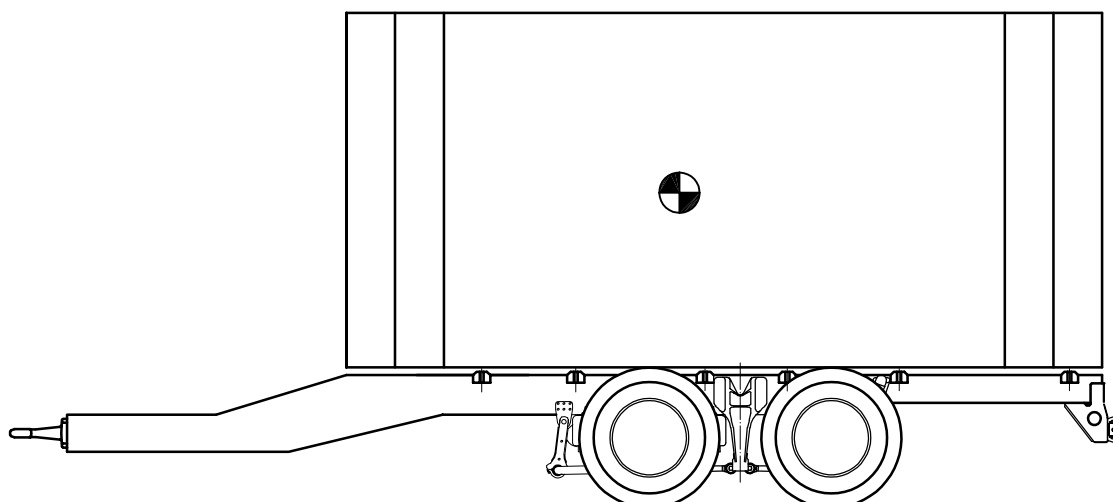

a) Case A

Figure 1 — Examples

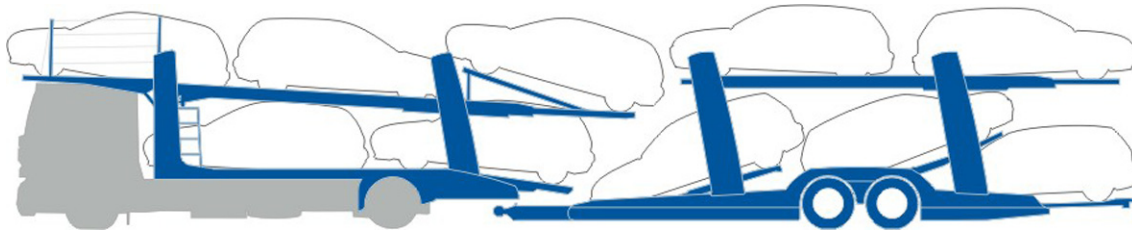

b) Case B

Figure 1 (continued)

## 2 Normative references

The following referenced documents are indispensable for the application of this document. For dated references, only the edition cited applies. For undated references, the latest edition of the referenced document (including any amendments) applies.

ISO 1176, *Road vehicles — Masses — Vocabulary and codes*

UNECE Regulation R55-01

## 3 Terms and definitions

For the purposes of this document, the following terms and definitions apply.

**3.1**  
**S-value**  
mass imposed vertically on the coupling under static conditions at rigid drawbar trailer/dolly loaded to its maximum design total mass

**3.2**  
**rigid drawbar trailer**  
towed vehicle equipped with a towing device which cannot move vertically (in relation to the trailer), and in which the axle(s) is(are) positioned less close to the centre of gravity of the vehicle (when uniformly loaded) such that a vertical static load  $S$  exceeding 10 % of the load corresponding to the maximum design total mass of the trailer and/or vertical static load  $S$  greater than 1 000 kg and up to 2 000 kg is transmitted to the towing vehicle

## 4 General test requirements

**4.1** The test may be carried out with drawbeams, drawbar couplings and drawbar eyes/special coupling devices having corresponding functional dimensions.

**4.2** The strength tests described in this International Standard are static and dynamic tests to be performed on a test bed.

**4.3** The fixing arrangements for the drawbar coupling/special coupling device and the drawbar eye/special drawbar device on the test bed shall be those intended for their attachment to the vehicles in accordance with the coupling manufacturer's fitting instructions.

**4.4** Drawbeams, drawbar couplings and drawbar eyes may be tested either separately or together. Special coupling devices intended only for vehicle transport combinations (see class T defined in ECE R 55-01) are to be tested together.

**4.5** Preferably, couplings are tested in the original condition as being foreseen for use on the road. At the discretion of the manufacturer and in agreement with the test laboratory, flexible components may be neutralized if this is necessary for the test procedure and if there is no concern about unrealistic influence on the test result.

**4.6** Flexible components being apparently overstressed due to this accelerated test procedure are allowed to be replaced during the test.

**4.7** The test loads may be applied by means of special slack-free devices.

## 5 Determination of $D_c$ - and $V$ -value — Vehicle demands

### 5.1 General

The  $D_c$ -value is a comparative value determined by calculation for the longitudinal forces occurring between towing vehicle and trailer.

The  $V$ -value is a comparative value determined by calculation for the vertical forces occurring between towing vehicle and trailer.

### 5.2 Case A

**5.2.1**  $D_c$ , expressed in kN, shall be calculated with the following equation:

$$D_c = g \times \frac{T \times C}{T + C}$$

where

$T$  is the maximum design total mass of the towing vehicle, including  $S$ , to which the drawbar coupling is to be attached, in tonnes;

$C$  is the mass transmitted to the ground by the axle(s) of the rigid drawbar trailer loaded to its maximum design total mass, in tonnes;

$g$  is the acceleration due to gravity:  $g = 9,81 \text{ m/s}^2$ .

Terminology for the different masses shall be taken with the meanings given in the corresponding definitions in ISO 1176.

**5.2.2**  $V$ , expressed in kN, shall be calculated with the following equation:

$$V = a \times \frac{x^2}{L^2} \times (0,95 \times C + S/1000)$$

where

$a$  is an equivalent vertical acceleration in the coupling point, depending on the kind of suspension on the rear axle(s) of the towing vehicle, including a constant factor:

$a = 1,8 \text{ m/s}^2$  for towing vehicles with air suspension (or systems with equivalent damping characteristics),

$a = 2,4 \text{ m/s}^2$  for towing vehicles with other types of suspension systems;

$C$  is the mass transmitted to the ground by the axle(s) of the rigid drawbar trailer loaded to its maximum design total mass, in tonnes;

$x$  is the length of the loading area of the trailer, in metres (see Figure 2);

$L$  is the theoretical drawbar length, i.e. the distance between the centre of the drawbar eye and the centre of the axle assembly, in metres (see Figure 2);

$S$  is the S-value, as defined in 3.1, in kilograms.

If calculation  $\left(\frac{x^2}{L^2}\right)$  is less than 1, the value 1 shall be used.

Terminology for the different masses shall be taken with the meanings given in the corresponding definitions in ISO 1176.

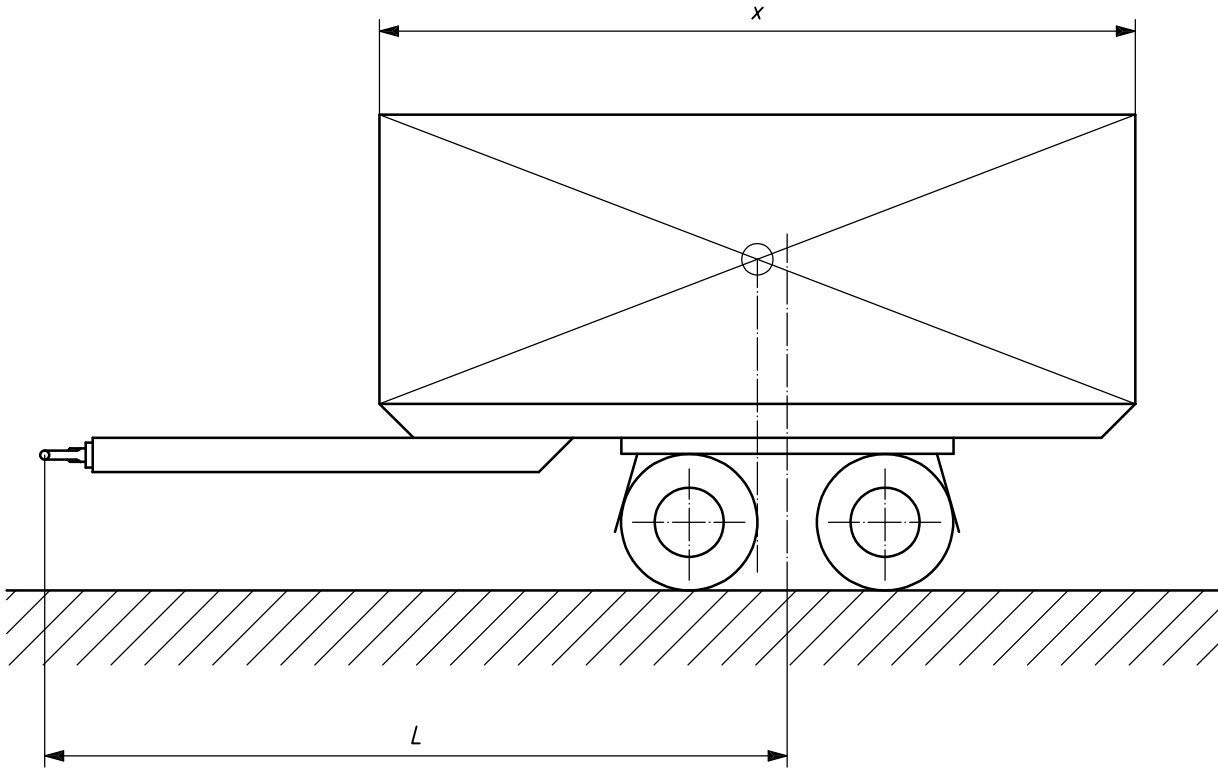

Figure 2 — Dimensions of the rigid drawbar trailer

### 5.3 Case B

5.3.1  $D_c$ , expressed in kN, shall be calculated with the following equation:

$$D_c = 0,8 \times g \times \frac{T \times C}{T + C}$$

where

$T$  is the maximum design total mass of the towing vehicle, including  $S$ , to which the drawbar coupling is to be attached, in tonnes;

$C$  is the mass transmitted to the ground by the axle(s) of the rigid drawbar trailer loaded to its maximum design total mass, in tonnes;

$g$  is the acceleration due to gravity:  $g = 9,81 \text{ m/s}^2$ .

Terminology for the different masses shall be taken with the meanings given in the corresponding definitions in ISO 1176.

5.3.2  $V$ , expressed in kN, shall be calculated with the following equation:



$$V = 0,8 \times a \times \frac{x^2}{L^2} \times C$$

where

*a* is an equivalent vertical acceleration in the coupling point, depending on the kind of suspension on the rear axle(s) of the towing vehicle, including a constant factor:

*a* = 1,8 m/s<sup>2</sup> for towing vehicles with air suspension (or systems with equivalent damping characteristics),

*a* = 2,4 m/s<sup>2</sup> for towing vehicles with other types of suspension systems;

*C* is the mass transmitted to the ground by the axle(s) of the rigid drawbar trailer loaded to its maximum design total mass, in tonnes;

*x* is the length of the loading area of the trailer, in metres (see Figure 2);

*L* is the theoretical drawbar length, i.e. the distance between the centre of the drawbar eye and the centre of the axle assembly, in metres (see Figure 2);

If calculation  $\left(\frac{x^2}{L^2}\right)$  is less than 1, the value 1 shall be used.

Terminology for the different masses shall be taken with the meanings given in the corresponding definitions in ISO 1176.

## 6 Dynamic tests — Coupling equipment performance

6.1 The dynamic test loads given in Table 1, simulating practical loads under driving conditions, shall be applied to the coupling point.

Table 1 — Dynamic test loads

Test load	Mean value kN	Amplitude kN
Horizontal load, $F_h, t$	0	$\pm 0,6 \times D_c$
Vertical load, $F_v, t$	$g \times S / 1\,000$	$\pm 0,6 \times V$
where		
<i>D<sub>c</sub></i> is determined according to 5.2.1 or 5.3.1, as applicable;		
<i>V</i> is determined according to 5.2.2 or 5.3.2, as applicable;		
<i>S</i> is defined in 3.1.		

6.2 The dynamic test forces are the vectorial sum of the vertical and horizontal component as specified in Table 1. This can be achieved by the test bed configuration shown in Figure 3. The vertical and the horizontal components shall have a sinusoidal shape (see Figure 4) and shall be applied asynchronously, where the difference between their frequencies shall be between 1 % and 3 %, so that resulting test forces in all directions are created.

6.3 For steel materials, the dynamic test shall be carried out for  $2 \times 10^6$  cycles. For other materials, the number of cycles should be agreed between the coupling manufacturer and the test laboratory.

6.4 The selected frequency shall not exceed 25 Hz, and shall not coincide with the natural frequency of the system.

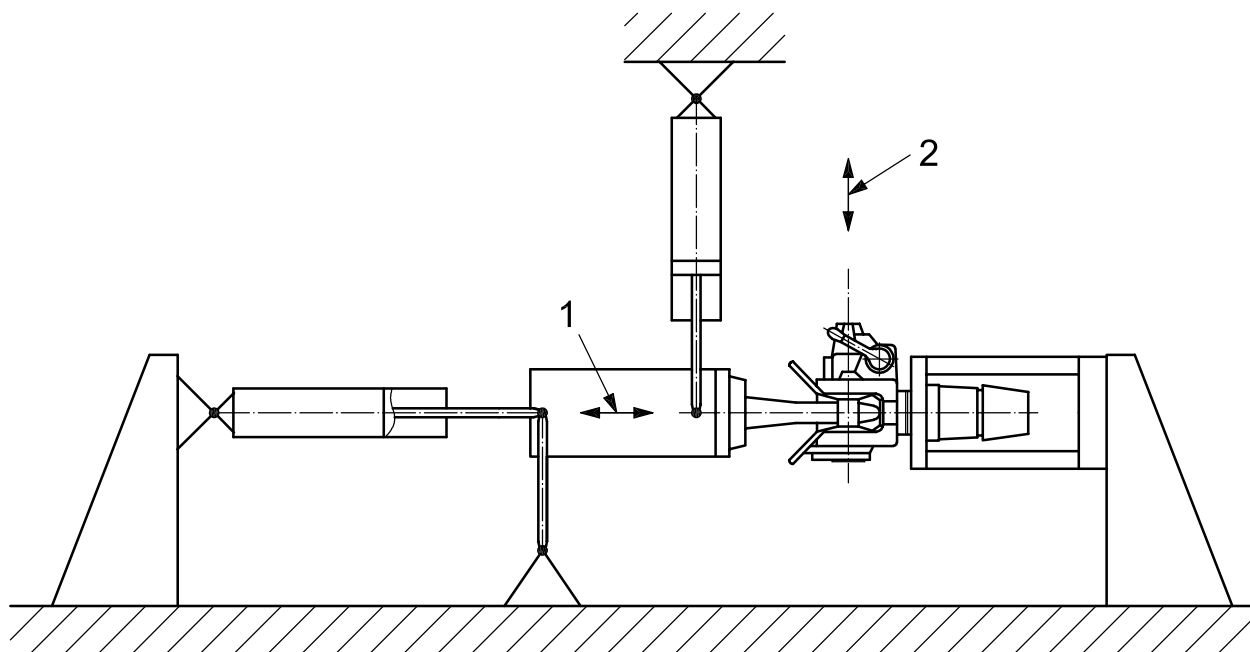

**Key**

- 1 horizontal test load
- 2 vertical test load

**Figure 3 — Example of test bed configuration**

**7 Static test**

With drawbar couplings or special coupling devices, it is also necessary to test the closure and any locking devices by means of a static force  $0,25 D_c$  acting in the direction of opening.

A test force of  $0,1 D_c$  is sufficient in the case of cylindrical coupling pins.

**8 Strength criteria**

The dynamic tests shall not cause permanent deformation, fractures or cracks. The static test shall not cause the closure to open and it shall not cause any damage.

<http://www.iso.org/iso/12357-2.htm>

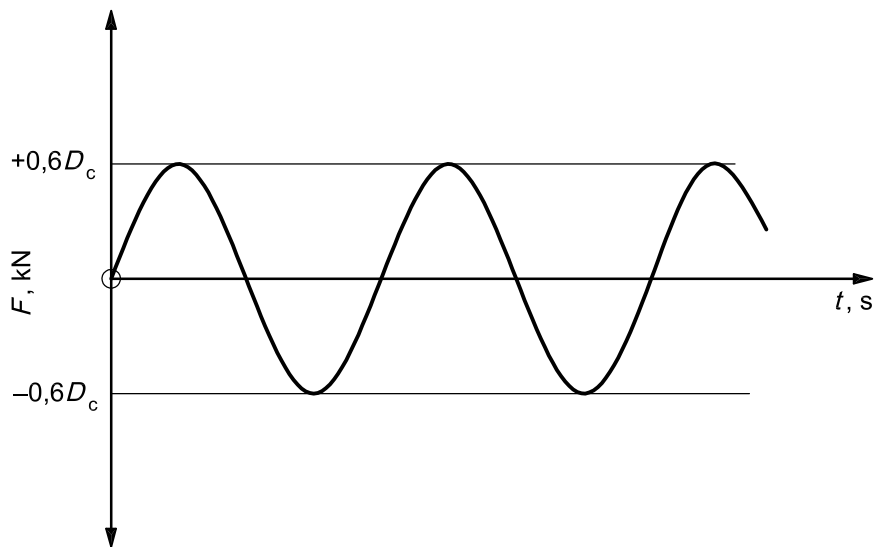

a) Horizontal load

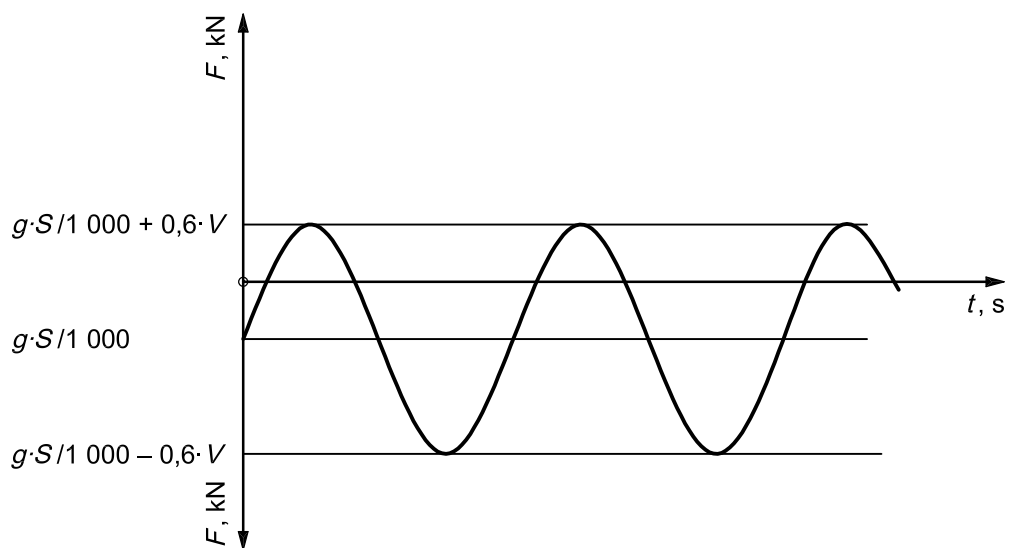

b) Vertical load

Figure 4 — Dynamic test loads

## Bibliography

- [1] ISO 1102, *Commercial road vehicles — 50 mm drawbar eye — Interchangeability*
- [2] ISO 3584, *Road vehicles — Drawbar couplings — Interchangeability*
- [3] European Directive 94/20/EC

.....

---

---

**ICS 43.040.70**

Price based on 8 pages