

INTERNATIONAL  
STANDARD

ISO  
12290

First edition  
2000-03-01

---

---

**Aerospace — Rivets, solid, in titanium or  
titanium alloy — Procurement specification**



Reference number  
ISO 12290:2000(E)

© ISO 2000

**PDF disclaimer**

This PDF file may contain embedded typefaces. In accordance with Adobe's licensing policy, this file may be printed or viewed but shall not be edited unless the typefaces which are embedded are licensed to and installed on the computer performing the editing. In downloading this file, parties accept therein the responsibility of not infringing Adobe's licensing policy. The ISO Central Secretariat accepts no liability in this area.

Adobe is a trademark of Adobe Systems Incorporated.

Details of the software products used to create this PDF file can be found in the General Info relative to the file; the PDF-creation parameters were optimized for printing. Every care has been taken to ensure that the file is suitable for use by ISO member bodies. In the unlikely event that a problem relating to it is found, please inform the Central Secretariat at the address given below.

© ISO 2000

All rights reserved. Unless otherwise specified, no part of this publication may be reproduced or utilized in any form or by any means, electronic or mechanical, including photocopying and microfilm, without permission in writing from either ISO at the address below or ISO's member body in the country of the requester.

ISO copyright office  
Case postale 56 CH-1211 Geneva 20  
Tel. + 41 22 749 01 11  
Fax + 41 22 734 10 79  
E-mail [copyright@iso.ch](mailto:copyright@iso.ch)  
Web [www.iso.ch](http://www.iso.ch)

Printed in Switzerland

## Contents

Page

Foreword.....	iv
1 Scope .....	1
2 Normative references .....	1
3 Terms and definitions .....	1
4 Quality assurance .....	3
4.1 General.....	3
4.1.1 Approval of manufacturers.....	3
4.1.2 Acceptance of solid rivets .....	3
4.2 Acceptance inspection and test conditions .....	3
4.3 Use of "Statistical process control (SPC)" .....	4
5 Requirements and test methods .....	4
6 Records and test reports .....	10
7 Certificate of compliance .....	11

## **Foreword**

ISO (the International Organization for Standardization) is a worldwide federation of national standards bodies (ISO member bodies). The work of preparing International Standards is normally carried out through ISO technical committees. Each member body interested in a subject for which a technical committee has been established has the right to be represented on that committee. International organizations, governmental and non-governmental, in liaison with ISO, also take part in the work. ISO collaborates closely with the International Electrotechnical Commission (IEC) on all matters of electrotechnical standardization.

International Standards are drafted in accordance with the rules given in the ISO/IEC Directives, Part 3.

Draft International Standards adopted by the technical committees are circulated to the member bodies for voting. Publication as an International Standard requires approval by at least 75 % of the member bodies casting a vote.

Attention is drawn to the possibility that some of the elements of this International Standard may be the subject of patent rights. ISO shall not be held responsible for identifying any or all such patent rights.

International Standard ISO 12290 was prepared by Technical Committee ISO/TC 20,  
Subcommittee SC 4,

# Aerospace — Rivets, solid, in titanium or titanium alloy — Procurement specification

## 1 Scope

This International Standard specifies the characteristics and quality assurance requirements for solid rivets made in titanium or titanium alloy for aerospace construction.

It is applicable whenever it is referenced in a definition document.

## 2 Normative references

The following normative documents contain provisions which, through reference in this text, constitute provisions of this International Standard. For dated references, subsequent amendments to, or revisions of, any of these publications do not apply. However, parties to agreements based on this International Standard are encouraged to investigate the possibility of applying the most recent editions of the normative documents indicated below. For undated references, the latest edition of the normative document referred to applies. Members of ISO and IEC maintain registers of currently valid International Standards.

ISO 2859-1:1999,

ISO 7870:1993,

ISO 7966:1993,

ISO 8258:1991,

ISO 9002:1994,

ISO 17057:1999,

ISO/TR 13425:1995,

## 3 Terms and definitions

For the purposes of this International Standard, the following terms and definitions apply.

### 3.1

#### **batch**

quantity of finished rivets, using the same process, from a single material cast (single heat of alloy), having the same number of definition document, diameter and length code, heat treated together to the same specified condition and produced as one continuous run

**3.2**

**rivet wire sample**

length of wire, sampled at one end of the coil used for the manufacture of rivets of the batch

NOTE The rivet wire samples should undergo the same heat treatments as the rivets of the batch, at the same time.

**3.3**

**rivet sample**

rivet sampled at random from the batch

**3.4**

**definition document**

document specifying directly or indirectly all the requirements for rivets

NOTE The definition document may be an International Standard, an in-house standard or a drawing.

**3.5**

**crack**

rupture in the material which may extend in any direction and which may be intercrystalline or transcrystalline in character

**3.6**

**seam**

longitudinal open surface defect

**3.7**

**lap**

surface defect caused by folding over metal fins or sharp corners and then forming them into the surface

**3.8**

**cold shut**

doubling over of metal which may occur during the cold heading operation

**3.9**

**blistering**

defect in the metal on or near the surface, resulting from expansion of gas in a sub-surface zone

**3.10**

**pit**

small sharp cavity in a metal surface caused by non-uniform electrodeposition or by corrosion

**3.11**

**critical defect**

defect that, according to judgement and experience, is likely to result in hazardous or unsafe conditions for individuals using, maintaining, or depending upon the considered product, or that is likely to prevent performance of the function of a major end item

**3.12**

**major defect**

defect, other than critical, that is likely to result in a failure or to reduce materially the usability of the considered product for its intended purpose

**3.13**

**minor defect**

defect that is not likely to reduce materially the usability of the considered product for its intended purpose, or that represents a departure from established specification having little bearing on the effective use or operation of this product

**3.14****sampling plan**

plan according to which one or more samples are taken in order to obtain information and to reach a decision, if possible

**3.15****acceptance quality limit****AQL**

maximum percent defective (or the maximum number of defects per hundred units) that, for purposes of sampling inspection, can be considered satisfactory as a process average

NOTE Variant: quality limit which in a sampling plan corresponds to a specified but relatively high probability of acceptance.

**4 Quality assurance****4.1 General****4.1.1 Approval of manufacturers**

The manufacturer shall conform to the quality assurance and approval procedures defined in ISO 9002. The purpose of these procedures is to ensure that a manufacturer has a quality system and is capable of continuous production of solid rivets complying with the specified quality requirements.

The approval of the manufacturer shall be granted by the Certification Authorities, or their appointed representative, who may be the prime contractor.

**4.1.2 Acceptance of solid rivets**

The purpose of acceptance inspection and tests of a solid rivet is to check, as simply as possible, using a method which is inexpensive but the most representative of the actual conditions of use, with the uncertainty inherent in statistical sampling, that the solid rivets satisfy the requirements of this International Standard.

Acceptance inspections and tests shall be carried out by the manufacturer, or under his responsibility.

The manufacturer is responsible for the quality of the solid rivets manufactured.

**4.2 Acceptance inspection and test conditions**

Acceptance inspections and tests (requirements, methods, numbers of solid rivets) are specified in Table 1. They shall be carried out on each batch. Solid rivets shall be selected from the batch to be tested by simple random sampling.

Each solid rivet may be submitted to several inspections or tests, provided that none of its characteristics to be verified has been previously altered during any of these inspections or tests.

The solid rivets to be subjected to destructive inspections or tests may be those on which non-destructive inspections or tests have been carried out.

Batches declared unacceptable after the acceptance inspection shall be resubmitted for acceptance only after all the defective units have been removed and/or defects have been corrected.

In this case, the attribute(s) which caused the rejection shall be verified using a sample of twice the normal size with the same acceptance limit.

If the reason for rejection results from the method, the test apparatus or from faulty heat treatment which can be rectified in a satisfactory manner, the tests may be repeated after elimination of the cause, provided that any

surface treatment be removed prior to heat treatment, without being detrimental to rivet final use. A note to this effect shall be added to the corresponding inspection documents.

Unless otherwise specified, the test temperature shall be the ambient temperature.

**4.3 Use of "Statistical process control (SPC)"**

When a characteristic is obtained by a controlled statistical process, the manufacturer has the possibility, in order to declare conformity of the characteristic, of refraining from the final systematic sampling provided for in this International Standard, if he is capable of **formally justifying** this choice by using ISO/TR 13425 and the standards quoted in it as a basis.

This justification will include the following phases:

- analysis of the product's key characteristics;
- analysis of the risks for each implemented process;
- determination of the parameters and/or characteristics to be respected under SPC;
- determination of the capabilities of each process;
- drawing up an inspection plan and integration in the manufacturing process;
- drawing up of routes and control charts (ISO 7966, ISO 7870, ISO 8258);
- use of control charts for data consolidation;
- determination of the audits to be run and the control to be carried out to ensure reliability of the device.

To be usable in production, this process shall be or should be validated beforehand by the qualifying body, either during the qualification phase, or according to the case, by analysing the justificatory file and the results of the qualification inspections such as provided for in clause 5.

**5 Requirements and test methods**

See Table 1.

**Table 1 — Requirements and test methods**

Clause	Characteristic	Requirement	Inspection and test method	Classification of defects and sampling
5.1	Material	In accordance with the product standard or definition document	See material standard.	
5.2	Dimensions	In accordance with the product standard or definition document	Usual instruments  In case of dispute, the projection method at a magnification of 25 times for diameters 6 mm and 10 times for diameters 6 mm, shall be used as the reference method. Checks shall be made at three equidistant points around the rivet.	Table 2



Table 1

Clause	Characteristic	Requirement	Inspection and test method	Classification of defects and sampling
5.3	<b>Manufacturing</b>			
5.3.1	<b>Heat treatment</b>	As specified in the material standard.		
5.3.2	<b>Workmanship</b>	No cracks or blistering.  Localized, non-continuous seams, laps, cold shuts, tool marks and pits having a maximum depth of 0,07 mm are permissible.	Visual examination with or without magnification. The magnification shall be limited to six times.  Defect depth shall be measured perpendicular to a line tangent with the surface.  In the event of any doubt, the test specified in 5.4.2 shall be used as the reference method.	Table 2
5.3.3	<b>Surface treatment</b>	Treatment: — in accordance with the product standard or definition document; — anodizing thickness is not mandatory.	See applicable surface treatment standard.	Table 2
5.4	<b>Mechanical properties</b>			
5.4.1	<b>Double shear strength</b>	See Table 3.	ISO 17057	Table 4
5.4.2	<b>Drivability</b>	No cracks permitted	Test device: see Figure 1.  Test method: a) progressively upset the protruding end, until the values specified in Figure 2 are obtained; b) examine visually without magnification.  Sample definition: see Figure 3.  Test carried out at delivery condition.	Table 2
5.5	<b>Metallurgical properties</b>			
5.5.1	<b>Hydrogen</b>	Rivets shall not have hydrogen content that exceeds 85 g/g.	Procedures and equipment capable of analysing hydrogen to an accuracy of 0,001 0 % (10 g/g)	One test per batch
5.6	<b>Product identification marking</b>	In accordance with the product standard or definition document.	Visual examination	Table 2

Table 1

Clause	Characteristic	Requirement	Inspection and test method	Classification of defects and sampling
5.7	<b>Delivery</b>			
5.7.1	<b>Packaging</b>	<p>The packaging shall:</p> <ul style="list-style-type: none"> <li>— prevent any damage or corrosion from occurring during handling, transportation and storage;</li> <li>— only contain rivets from the same batch, the number of which is left to the manufacturer's discretion; however, the maximum mass is 25 kg;</li> <li>— contain a copy of the manufacturer's delivery note relating to the batch. Furthermore, this note may be sent separately upon request.</li> </ul> <p>Any particular or additional packaging requirements shall be specified with the order.</p>	Visual examination	
5.7.2	<b>Labelling</b>	<p>Durable labels, secured to the packaging, bearing the following information:</p> <ul style="list-style-type: none"> <li>— designation;</li> <li>— quantity (mass or number);</li> <li>— manufacturer's name;</li> <li>— batch number.</li> </ul>	Visual examination	

Table 2 — Classification of defects

Category of defects	Acceptance quality limit (AQL)	Characteristics
<b>Major</b>	See Table 5.	Head diameter Head angle Head protrusion Product identification marking <sup>a</sup> Shank diameter Length Cracks Blistering
	See Table 6.	Drivability during installation
<b>Minor</b>	See Table 6.	All other dimensions, appearance items and miscellaneous defects

<sup>a</sup> Including legibility.

Table 3 — Double shear strength

Rivet diameter <sup>a</sup>		Minimum double shear strength (N) <sup>b</sup>	
$D_1$ mm		Alloy designation (minimum shear stress)	
nom.	min.	T40 (330 MPa)	55Ti-45Cb (345 MPa)
1,6	1,52	1 197	1 252
2	1,92	1 911	1 998
2,5	2,42	3 036	3 174
3	2,92	4 420	4 621
3,5	3,395	5 974	6 246
4	3,895	7 864	8 222
5	4,895	12 420	12 985
6	5,895	18 013	18 832
8	7,87	32 105	33 565
10	9,87	50 498	52 793

<sup>a</sup> For other diameters, use the formula given in footnote <sup>b</sup>.

<sup>b</sup> Values calculated using the following formula:

$$(D_1 \text{ min.})^2 \frac{2}{4} (\text{min. shear stress})$$

**Table 4 — Sampling plans for the inspection of double shear strength**

Batch size	Sample size	Inspection level	Sampling plan <sup>a,b</sup>			AQL %
			Sampling number	Acceptance	Rejection	
500	2	S-1	First	0	2	15
			Second	1		
501 to 35 000	3		First	0		10
			Second	1		
35 001	5		First	0		6,5
			Second	1		

<sup>a</sup> In accordance with ISO 2859-1, double sampling, normal inspection.

<sup>b</sup> Other sampling plans of ISO 2859-1 may be used, provided that they ensure an equivalent quality limit.

**Table 5 — Sampling plans for visual inspection and inspection of dimensional characteristics**

Batch size	Sample size	Inspection level	Sampling plan <sup>a,b</sup>			AQL %
			Sampling number	Acceptance	Rejection	
91 to 150	5	I	First	0	3	10
			Second	3	4	
151 to 280	8		First	0	3	6,5
			Second	3	4	
281 to 500	13		First	1	4	
			Second	4	5	
501 to 1 200			First	0	3	4
			Second	3	4	
1 201 to 10 000	20		First	2	5	6,5
			Second	6	7	
10 001 to 35 000		First	1	3	4	
		Second	4	5		
35 001 to 500 000	50	First	3	6		
		Second	9	10		
500 001	80	First	3	6	2,5	
		Second	9	10		

<sup>a</sup> In accordance with ISO 2859-1, double sampling, normal inspection.

<sup>b</sup> Other sampling plans of ISO 2859-1 may be used, provided that they ensure an equivalent quality limit.

Table 6 — Sampling plans for the inspection of mechanical and metallurgical characteristics

Batch size	Sample size	Inspection level	Sampling plan <sup>a,b</sup>			AQL %
			Sampling number	Acceptance	Rejection	
91 to 150	5	I	First	1	3	15
			Second	4	5	
151 to 500	8	S-4	First	1	3	10
501 to 3 200			Second	4	5	
	3 201 to 35 000	13	S-3	First	0	
Second				3	4	
35 001 to 500 000	20	First		2	5	
		Second		6	7	
500 001	32		First	3	6	6,5
			Second	9	10	

<sup>a</sup> In accordance with ISO 2859-1, double sampling, normal inspection.

<sup>b</sup> Other sampling plans of ISO 2859-1 may be used, provided that they ensure an equivalent quality limit.

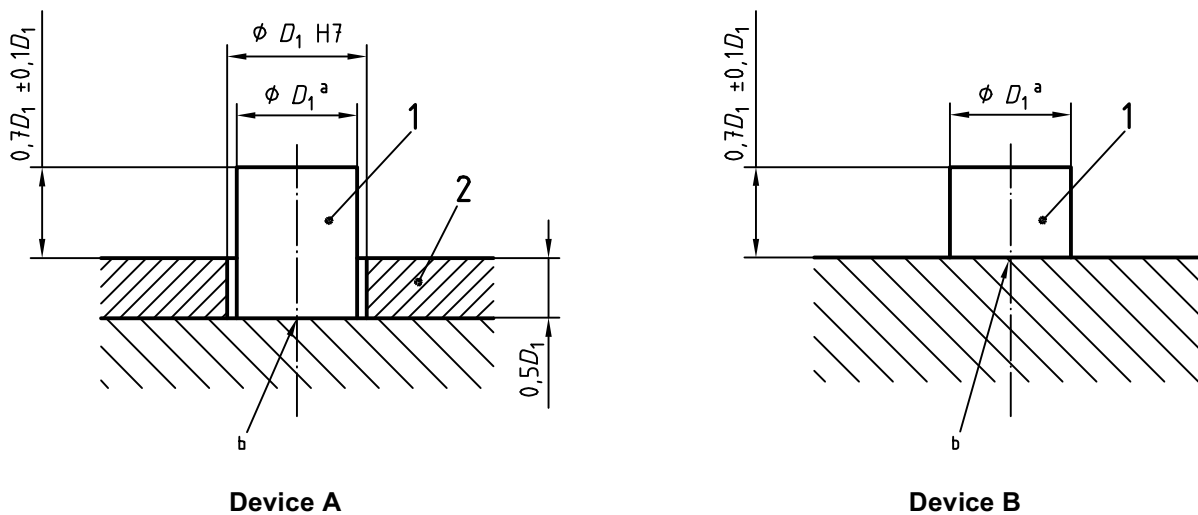

**Key**

- 1 Rivet sample (see Figure 3)
- 2 Steel plate

NOTE Test device A or B at discretion, device A to be used as the reference method in case of dispute.

- <sup>a</sup>  $D_1$  = rivet nominal diameter.
- <sup>b</sup> Preformed face.

Figure 1

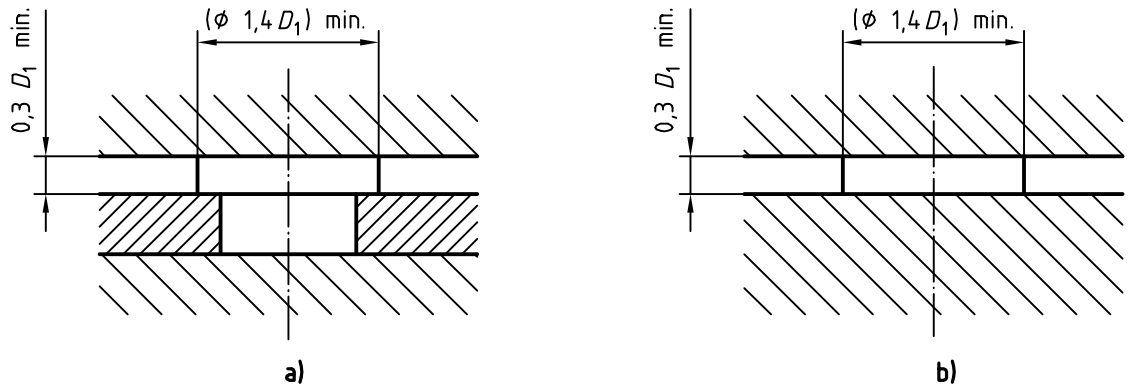

NOTE Figures 2 a) and 2 b) correspond to devices A and B in Figure 1, respectively.

Figure 2

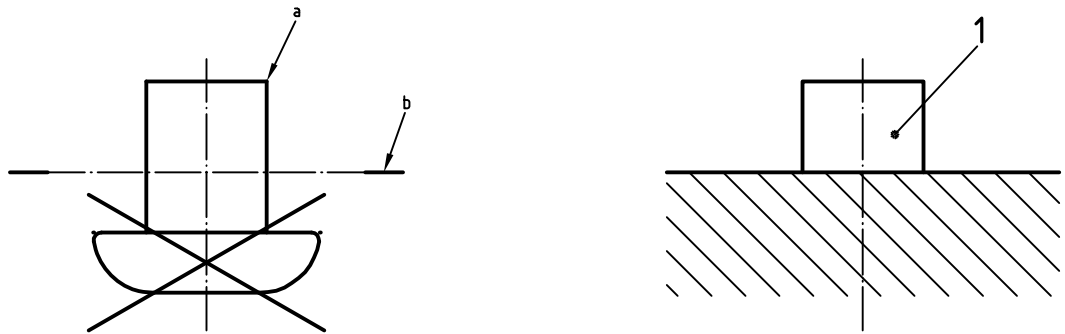

**Key**

- 1 Rivet sample
- a Tail end of rivet in delivery condition.
- b Cutting plane.

Figure 3

**6 Records and test reports**

For each batch, the manufacturer shall have on file, for at least five years, documentation which can be communicated to a user upon request. This documentation shall include at least:

- a) a copy of documents concerning the material batch and the test references;
- b) the documents concerning the heat treatment of the batch;
- c) the inspection results and tests of the batch.

## **7 Certificate of compliance**

Each shipment shall be accompanied by a certificate of compliance stating that the product satisfies the requirements of this International Standard.

