

---

---

**Aerospace — Nuts, anchor, self-locking, floating, self-aligning, two lug, with MJ threads, classifications: 900 MPa (at ambient temperature)/235 °C, 900 MPa (at ambient temperature)/315 °C and 900 MPa (at ambient temperature)/425 °C — Dimensions**

*Aéronautique et espace — Écrous à river, à freinage interne, flottants, orientables, double patte, à filetage MJ, classifications: 900 MPa (à température ambiante)/235 °C, 900 MPa (à température ambiante)/315 °C et 900 MPa (à température ambiante)/425 °C — Dimensions*



**PDF disclaimer**

This PDF file may contain embedded typefaces. In accordance with Adobe's licensing policy, this file may be printed or viewed but shall not be edited unless the typefaces which are embedded are licensed to and installed on the computer performing the editing. In downloading this file, parties accept therein the responsibility of not infringing Adobe's licensing policy. The ISO Central Secretariat accepts no liability in this area.

Adobe is a trademark of Adobe Systems Incorporated.

Details of the software products used to create this PDF file can be found in the General Info relative to the file; the PDF-creation parameters were optimized for printing. Every care has been taken to ensure that the file is suitable for use by ISO member bodies. In the unlikely event that a problem relating to it is found, please inform the Central Secretariat at the address given below.



**COPYRIGHT PROTECTED DOCUMENT**

© ISO 2010

All rights reserved. Unless otherwise specified, no part of this publication may be reproduced or utilized in any form or by any means, electronic or mechanical, including photocopying and microfilm, without permission in writing from either ISO at the address below or ISO's member body in the country of the requester.

ISO copyright office  
Case postale 56 • CH-1211 Geneva 20  
Tel. + 41 22 749 01 11  
Fax + 41 22 749 09 47  
E-mail [copyright@iso.org](mailto:copyright@iso.org)  
Web [www.iso.org](http://www.iso.org)

Published in Switzerland

## Foreword

ISO (the International Organization for Standardization) is a worldwide federation of national standards bodies (ISO member bodies). The work of preparing International Standards is normally carried out through ISO technical committees. Each member body interested in a subject for which a technical committee has been established has the right to be represented on that committee. International organizations, governmental and non-governmental, in liaison with ISO, also take part in the work. ISO collaborates closely with the International Electrotechnical Commission (IEC) on all matters of electrotechnical standardization.

International Standards are drafted in accordance with the rules given in the ISO/IEC Directives, Part 2.

The main task of technical committees is to prepare International Standards. Draft International Standards adopted by the technical committees are circulated to the member bodies for voting. Publication as an International Standard requires approval by at least 75 % of the member bodies casting a vote.

Attention is drawn to the possibility that some of the elements of this document may be the subject of patent rights. ISO shall not be held responsible for identifying any or all such patent rights.

ISO 12273 was prepared by Technical Committee ISO/TC 20, *Aircraft and space vehicles*, Subcommittee SC 4, *Aerospace fastener systems*.

This second edition cancels and replaces the first edition (ISO 12273:1997), of which it constitutes a minor revision.

## Introduction

The dimensions specified in this International Standard have been determined to satisfy the requirements of the procurement specification of ISO 5858.

# Aerospace — Nuts, anchor, self-locking, floating, self-aligning, two lug, with MJ threads, classifications: 900 MPa (at ambient temperature)/235 °C, 900 MPa (at ambient temperature)/315 °C and 900 MPa (at ambient temperature)/425 °C — Dimensions

## 1 Scope

This International Standard specifies the dimensions of floating, self-aligning, two lug anchor nuts, with MJ threads and a self-locking feature achieved by forming the upper portion out-of-round, of the following classifications:

900 MPa/235 °C;

900 MPa/315 °C;

900 MPa/425 °C.

NOTE 1 The first element in the classifications (900 MPa) corresponds to the minimum tensile stress that the nut is able to withstand at ambient temperature without breaking or cracking when tested with a bolt of a higher strength class.

NOTE 2 The second element in the classifications is the maximum temperature that the nut is able to withstand, without permanent alteration to its original characteristics, after ambient temperature has been restored. The maximum temperature is conditioned by the material or by the surface treatment.

This International Standard is only applicable for the compilation of aerospace product standards.

## 2 Normative references

The following referenced documents are indispensable for the application of this document. For dated references, only the edition cited applies. For undated references, the latest edition of the referenced document (including any amendments) applies.

ISO 5855-2, *Aerospace — MJ threads — Part 2: Limit dimensions for bolts and nuts*

ISO 8788, *Aerospace — Nuts, metric — Tolerances of form and position*

## 3 Configuration and dimensions

See Figure 1 and Table 1.

Dimensions and tolerances are expressed in millimetres. They apply after any surface coating(s) but before the application of any lubricant.

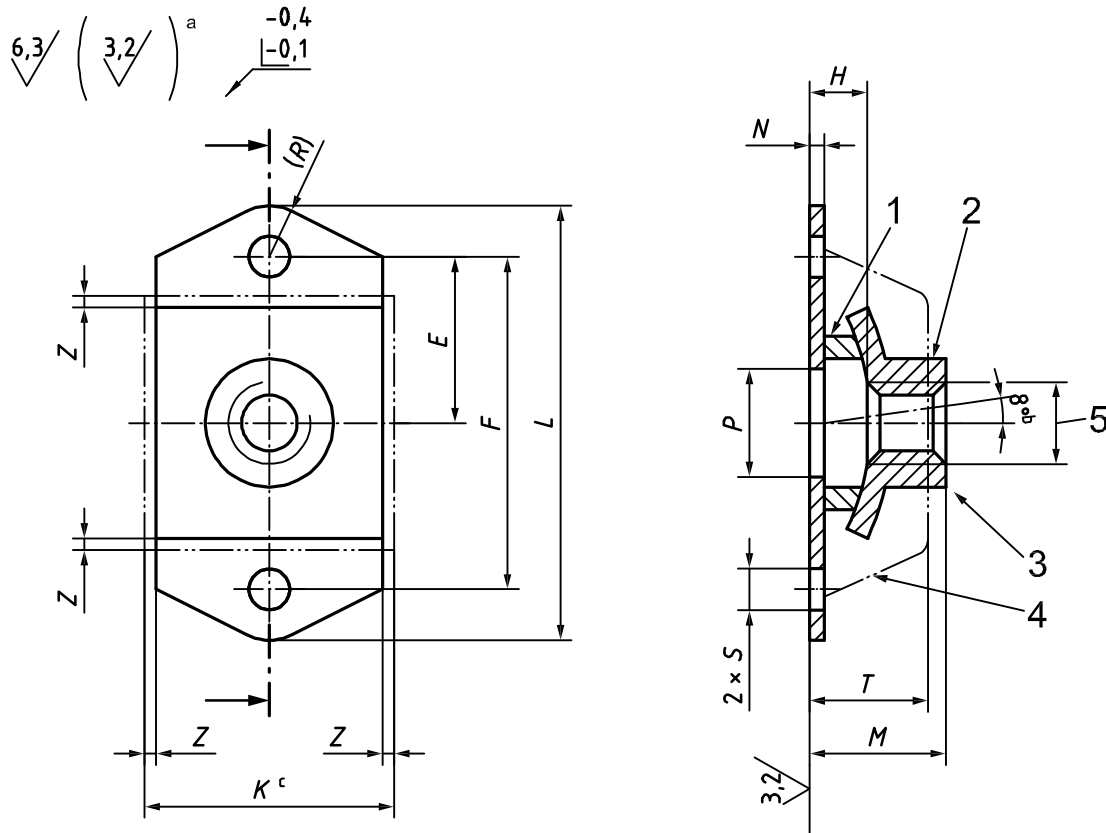

Tolerances of form and position shall conform to those specified in ISO 8788.

**Key**

- 1 convex washer
- 2 threaded element
- 3 form out-of-round in this area to achieve the self-locking torque requirement (tooling marks permissible)
- 4 cage
- 5 thread

a These values, in micrometers, apply before any surface coating(s) is(are) applied. The values do not apply to threads and sheared edges, the surface texture of which will be as achieved by the usual manufacturing methods.

b Axial misalignment: 8° minimum in any direction from central position.

c Float inclusive.

**Figure 1**

**Table 1**

Diameter code	Thread <sup>a</sup>	E	F	H	K	L	M	N <sup>b</sup>	P	R	S	T	Radial floating
				min.	max.	max.	max.					max.	min.
050	MJ5 × 0,8 – 4H6H	8,75	17,5	3,5	15,2	23,7	8,3	0,9	6,6	3	2,5	7,2	0,7
060	MJ6 × 1 – 4H5H	12,7	25,4	4	17	31,6	10,2		7,6			7,8	
080	MJ8 × 1 – 4H5H			5	20,5	32,6	11,8	1,1	11	3,5	8,4	0,75	

<sup>a</sup> In accordance with ISO 5855-2. In the self-locking zone, the tolerances apply before forming out-of-round.

<sup>b</sup> Is applicable at the rivet hole location.

## Bibliography

- [1] ISO 5858, *Aerospace — Nuts, self-locking, with maximum operating temperature less than or equal to 425 °C — Procurement specification*

