

INTERNATIONAL STANDARD

ISO 12268

First edition
1997-08-01

Aerospace — Nuts, hexagonal, plain, reduced height, reduced across flats, with MJ threads, classifications: 450 MPa (at ambient temperature)/425 °C, 600 MPa (at ambient temperature)/235 °C, 600 MPa (at ambient temperature)/315 °C, 600 MPa (at ambient temperature)/650 °C, 900 MPa (at ambient temperature)/235 °C, 900 MPa (at ambient temperature)/730 °C and 1 100 MPa (at ambient temperature)/600 °C — Dimensions

Aéronautique et espace — Écrous hexagonaux ordinaires, hauteur réduite, surplats réduits, à filetage MJ, classifications: 450 MPa (à température ambiante)/425 °C, 600 MPa (à température ambiante)/235 °C, 600 MPa (à température ambiante)/315 °C, 600 MPa (à température ambiante)/650 °C, 900 MPa (à température ambiante)/235 °C, 900 MPa (à température ambiante)/730 °C et 1 100 MPa (à température ambiante)/600 °C — Dimensions



Reference number
ISO 12268:1997(E)

Foreword

ISO (the International Organization for Standardization) is a worldwide federation of national standards bodies (ISO member bodies). The work of preparing International Standards is normally carried out through ISO technical committees. Each member body interested in a subject for which a technical committee has been established has the right to be represented on that committee. International organizations, governmental and non-governmental, in liaison with ISO, also take part in the work. ISO collaborates closely with the International Electrotechnical Commission (IEC) on all matters of electrotechnical standardization.

Draft International Standards adopted by the technical committees are circulated to the member bodies for voting. Publication as an International Standard requires approval by at least 75 % of the member bodies casting a vote.

International Standard ISO 12268 was prepared by Technical Committee ISO/TC 20, *Aircraft and space vehicles*, Subcommittee SC 4, *Aerospace fastener systems*.

© ISO 1997

All rights reserved. Unless otherwise specified, no part of this publication may be reproduced or utilized in any form or by any means, electronic or mechanical, including photocopying and microfilm, without permission in writing from the publisher.

International Organization for Standardization
Case postale 56 • CH-1211 Genève 20 • Switzerland
Internet central@iso.ch
X.400 c=ch; a=400net; p=iso; o=isocs; s=central

Printed in Switzerland

Introduction

The dimensions specified in this International Standard have been determined to satisfy the requirements of the procurement specification of ISO 9139.

1

Aerospace — Nuts, hexagonal, plain, reduced height, reduced across flats, with MJ threads, classifications: 450 MPa (at ambient temperature)/425 C, 600 MPa (at ambient temperature)/235 C, 600 MPa (at ambient temperature)/315 C, 600 MPa (at ambient temperature)/650 C, 900 MPa (at ambient temperature)/235 C, 900 MPa (at ambient temperature)/730 C and 1 100 MPa (at ambient temperature)/600 C — Dimensions

1 Scope

This International Standard specifies the dimensions of plain, hexagonal nuts, reduced height, reduced across flats, with MJ threads, of classifications: 450 MPa¹/425 C², 600 MPa¹/235 C², 600 MPa¹/315 C², 600 MPa¹/650 C², 900 MPa¹/235 C², 900 MPa¹/730 C² and 1 100 MPa¹/600 C².

Nuts provided with holes are intended to be used with lockwire in conformity with ISO 245.

This International Standard is only applicable for the compilation of aerospace product standards.

2 Normative references

The following standards contain provisions which, through reference in this text, constitute provisions of this International Standard. At the time of publication, the editions indicated were valid. All standards are subject to revision, and parties to agreements based on this International Standard are encouraged to investigate the possibility of applying the most recent editions of the standards indicated below. Members of IEC and ISO maintain registers of currently valid International Standards.

ISO 245:1986, *Aircraft — Lockwire*.

ISO 5855-2:1988, *Aerospace — MJ threads — Part 2: Limit dimensions for bolts and nuts*.

ISO 8788:1987, *Aerospace — Fasteners — Tolerances of form and position for nuts*.

ISO 9139:—³, *Aerospace — Nuts, plain or slotted (castellated) — Procurement specification*.

3 Configuration and dimensions

See figure 1 and table 1. Dimensions and tolerances are expressed in millimetres. They apply after any surface coating(s) but before the application of any lubricant.

- 1) Corresponds to the minimum tensile stress which the nut is able to withstand at ambient temperature without breaking or cracking when tested with a bolt of a higher strength class.
- 2) Maximum temperature that the nut is able to withstand, without permanent alteration to its original characteristics, after ambient temperature has been restored. The maximum temperature is conditioned by the material or by the surface treatment.
- 3) To be published.

$6,3 / (1,6)^n$

Remove sharp edges 0,1 to 0,4

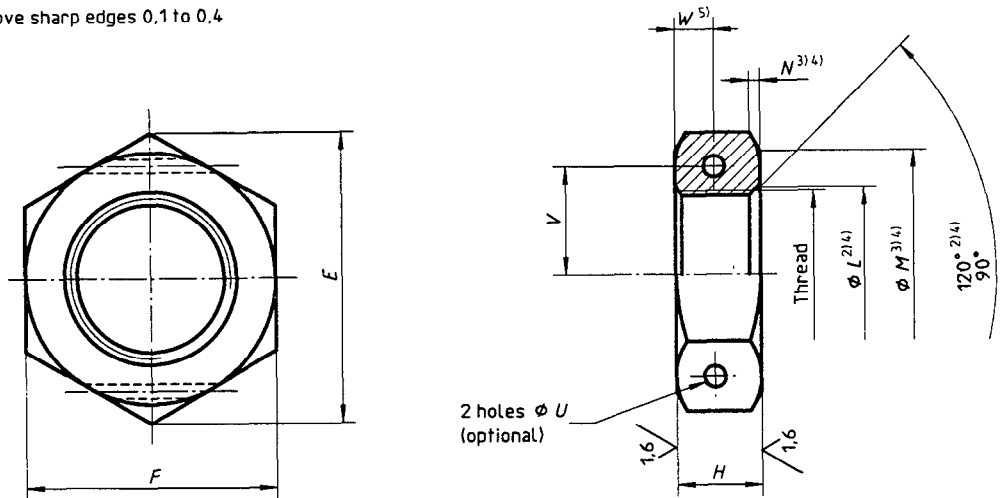

NOTE — Tolerances of form and position shall conform to those specified in ISO 8788.

- 1) These values, in micrometers, apply before any surface coating(s) is (are) applied. The values do not apply to threads the surface texture of which will be as achieved by the usual manufacturing methods.
- 2) All forms of entry (chamfer or radius) permissible within these limiting dimensions.
- 3) Form of contour, within limiting dimensions, is left to the manufacturer's discretion. Diameter *M* may be tangential to, but shall not intrude on the flats.
- 4) Applicable to both faces.
- 5) From either face.

Figure 1

Table 1

Diameter code	Thread ¹⁾	<i>E</i>	<i>F</i>	<i>H</i>	<i>L</i>	<i>M</i>	<i>N</i>	<i>U</i>	<i>V</i>	<i>W</i>	Lockwire diameter ²⁾
		min.	h13	h14	$+0,8 / 0$	min.	$0 / -0,3$	H13	-0,2	min.	
100	MJ10·1,25 - 4H5H	15,5	14	5	10,3	13,2	0,6	1	5,9	2,1	0,8
120	MJ12·1,25 - 4H5H	18,9	17	6	12,3	16		1,5	7,2	2,6	1,25
140	MJ14·1,5 - 4H5H	21,1	19	7	14,4	18			8,2	3,1	
160	MJ16·1,5 - 4H5H	24,5	22	8	16,4	21			9,7	3,6	
180	MJ18·1,5 - 4H5H	26,8	24	9	18,4	23			10,8	4,1	
200	MJ20·1,5 - 4H5H	30,2	27	10	20,4	26			12,5	4,6	
220	MJ22·1,5 - 4H5H	33,6	30	11	22,4	29			13,9	5	
240	MJ24·2 - 4H5H	35,8	32	12	24,5	30,9			14,9	5,5	

1) In accordance with ISO 5855-2
 2) For information, in conformity with ISO 245

ICS 49.030.30

Descriptors: aircraft industry, fasteners, MJ threads, nuts (fasteners), hexagonal nuts, classification, form specifications, dimensions.

Price based on 2 pages
