

---

---

**Small craft — Stability and buoyancy  
assessment and categorization —**

**Part 3:  
Boats of hull length less than 6 m**

*Petits navires — Évaluation et catégorisation de la stabilité et de la flottabilité —*

*Partie 3: Bateaux d'une longueur de coque inférieure à 6 m*





**COPYRIGHT PROTECTED DOCUMENT**

© ISO 2015, Published in Switzerland

All rights reserved. Unless otherwise specified, no part of this publication may be reproduced or utilized otherwise in any form or by any means, electronic or mechanical, including photocopying, or posting on the internet or an intranet, without prior written permission. Permission can be requested from either ISO at the address below or ISO's member body in the country of the requester.

ISO copyright office  
Ch. de Blandonnet 8 • CP 401  
CH-1214 Vernier, Geneva, Switzerland  
Tel. +41 22 749 01 11  
Fax +41 22 749 09 47  
copyright@iso.org  
www.iso.org

# Contents

Page

<b>Foreword</b> .....	<b>v</b>
<b>Introduction</b> .....	<b>vii</b>
<b>1 Scope</b> .....	<b>1</b>
<b>2 Normative references</b> .....	<b>2</b>
<b>3 Terms and definitions</b> .....	<b>2</b>
3.1 Primary.....	2
3.2 Downflooding.....	4
3.3 Condition and mass.....	5
3.4 Other definitions.....	7
<b>4 Symbols</b> .....	<b>9</b>
<b>5 Procedure</b> .....	<b>10</b>
5.1 Maximum load.....	10
5.2 Sailing or non-sailing.....	10
5.3 Tests to be applied.....	11
5.3.1 General.....	11
5.4 Alternatives.....	11
5.5 Variation in input parameters.....	11
<b>6 Tests to be applied to non-sailing boats</b> .....	<b>12</b>
6.1 General.....	12
6.2 Habitable non-sailing multihull boats.....	13
6.3 Downflooding.....	13
6.3.1 Requirements for downflooding openings.....	13
6.3.2 Downflooding height with maximum load.....	15
6.3.3 Downflooding height — outboard boats when starting.....	18
6.4 Recess size.....	18
6.4.1 Application.....	18
6.4.2 Simplified methods.....	19
6.4.3 Direct calculation method.....	20
6.5 Offset-load test.....	20
6.5.1 General.....	20
6.5.2 Simplified procedure for offset-load test.....	22
6.5.3 Full procedure for offset load-test.....	24
6.5.4 Procedure for gunwale load test.....	26
6.6 Heel due to wind action.....	27
6.6.1 General.....	27
6.6.2 Calculation.....	27
6.6.3 Requirement.....	27
6.7 Level flotation test.....	27
6.8 Basic flotation test.....	28
6.9 Capsize-recovery test.....	28
6.10 Detection and removal of water.....	29
<b>7 Tests to be applied to sailing boats</b> .....	<b>29</b>
7.1 General.....	29
7.2 Downflooding.....	30
7.3 Recess size.....	31
7.4 Flotation tests.....	31
7.4.1 Level flotation test.....	31
7.4.2 Basic flotation test.....	31
7.5 Capsize-recovery test.....	31
7.6 Knockdown recovery test.....	32
7.7 Wind stiffness test.....	33
7.7.1 General.....	33

7.7.2	Practical test.....	33
7.7.3	Compliance by calculation.....	34
7.7.4	Requirements.....	35
7.8	Inverted buoyancy.....	36
<b>8</b>	<b>Safety signs.....</b>	<b>37</b>
<b>9</b>	<b>Application.....</b>	<b>37</b>
9.1	Deciding the design category.....	37
9.2	Meaning of the design categories.....	37
<b>Annex A</b>	<b>(normative) Full method for required downflooding height.....</b>	<b>38</b>
<b>Annex B</b>	<b>(normative) Methods for calculating downflooding angle.....</b>	<b>41</b>
<b>Annex C</b>	<b>(normative) Method for flotation tests.....</b>	<b>43</b>
<b>Annex D</b>	<b>(normative) Flotation material and elements.....</b>	<b>48</b>
<b>Annex E</b>	<b>(normative) Calculation method for basic flotation requirement.....</b>	<b>50</b>
<b>Annex F</b>	<b>(normative) Information for owner's manual.....</b>	<b>52</b>
<b>Annex G</b>	<b>(informative) Summary of requirements.....</b>	<b>57</b>
<b>Annex H</b>	<b>(informative) Worksheets.....</b>	<b>59</b>
<b>Annex I</b>	<b>(informative) Illustration of recess retention level.....</b>	<b>76</b>
<b>Bibliography</b>	<b>.....</b>	<b>77</b>

## Foreword

ISO (the International Organization for Standardization) is a worldwide federation of national standards bodies (ISO member bodies). The work of preparing International Standards is normally carried out through ISO technical committees. Each member body interested in a subject for which a technical committee has been established has the right to be represented on that committee. International organizations, governmental and non-governmental, in liaison with ISO, also take part in the work. ISO collaborates closely with the International Electrotechnical Commission (IEC) on all matters of electrotechnical standardization.

The procedures used to develop this document and those intended for its further maintenance are described in the ISO/IEC Directives, Part 1. In particular the different approval criteria needed for the different types of ISO documents should be noted. This document was drafted in accordance with the editorial rules of the ISO/IEC Directives, Part 2 (see [www.iso.org/directives](http://www.iso.org/directives)).

Attention is drawn to the possibility that some of the elements of this document may be the subject of patent rights. ISO shall not be held responsible for identifying any or all such patent rights. Details of any patent rights identified during the development of the document will be in the Introduction and/or on the ISO list of patent declarations received (see [www.iso.org/patents](http://www.iso.org/patents)).

Any trade name used in this document is information given for the convenience of users and does not constitute an endorsement.

For an explanation on the meaning of ISO specific terms and expressions related to conformity assessment, as well as information about ISO's adherence to the WTO principles in the Technical Barriers to Trade (TBT) see the following URL: [Foreword - Supplementary information](#).

The committee responsible for this document is ISO/TC 188, *Small craft*.

This third edition cancels and replaces the second edition (ISO 12217-3:2013), of which it constitutes a minor revision. It incorporates the following modifications:

- Introduction and [Clause 9.2](#): the reference to the European Directive has been updated (2013/53/EU);
- [Clause 1](#), [subclauses 6.2](#), [6.3.1.5 d](#)) [3](#)) and [F.2 g](#)): vulnerable has been replaced with susceptible.
- [Clause 3](#): definitions [3.1.1](#), [3.3.5](#) and [3.4.9](#) have been amended;
- [Subclause 6.3.2.2](#) c): option 5 has been included;
- [Subclauses 6.4.2.3](#) and [6.4.2.4](#): the formulae coefficients have been corrected;
- [Subclauses 6.5.2.5](#) and [6.5.3.3 e](#)) [2](#)) and [Table G.1](#) have been slightly amended to remove inconsistencies.
- [Subclause 6.6.1](#) and [Table G.1](#): the formulae have been harmonised with ISO 12217-1;
- [Subclause 7.5.1 b](#)) has been aligned with the text in ISO 12217-2.
- [Subclause 9.2](#): the text has been amended;
- [Annex H](#): worksheets 2, 4, 6, 8 and 15 have been corrected to align with corrections listed above;
- [Annex I](#) has been added;
- Bibliography: reference to ISO 7010 has been added;
- Editorial and cross-referencing corrections have been made to definitions [3.2.2](#) and [3.2.3](#) and to [subclauses 6.4.1](#), [6.4.2.1](#), [6.4.2.2](#) and [6.4.2.3](#), to [Table G.2](#), and to [Annex H](#), worksheet 6.

ISO 12217 consists of the following parts, under the general title *Small craft — Stability and buoyancy assessment and categorization*:

## ISO 12217-3:2015(E)

- *Part 1: Non-sailing boats of hull length greater than or equal to 6 m*
- *Part 2: Sailing boats of hull length greater than or equal to 6 m*
- *Part 3: Boats of hull length less than 6 m*

## Introduction

This part of ISO 12217 enables the determination of the limiting environmental conditions to be determined for which an individual boat has been designed.

It enables the boat to be assigned to a design category appropriate to its design and maximum load. The design categories used align with those in the Recreational Craft Directive of the European Union, EU Directive 2013/53/EU.

[Annex H](#) provides worksheets to assist in the systematic assessment of a boat according to this part of ISO 12217.





# Small craft — Stability and buoyancy assessment and categorization —

## Part 3: Boats of hull length less than 6 m

**CAUTION** — Compliance with this part of ISO 12217 does not guarantee total safety or total freedom of risk from capsizing or sinking.

**IMPORTANT** — The electronic file of this document contains colours which are considered to be useful for the correct understanding of the document. Users should therefore consider printing this document using a colour printer.

### 1 Scope

This part of ISO 12217 specifies methods for evaluating the stability and buoyancy of intact (i.e. undamaged) boats. The flotation characteristics of craft susceptible to swamping are also encompassed.

The evaluation of stability and buoyancy properties using this part of ISO 12217 will enable the boat to be assigned to a design category (C or D) appropriate to its design and maximum load.

This part of ISO 12217 is applicable to boats of hull length less than 6 m, whether propelled by human or mechanical power, except habitable sailing multihulls. Boats of hull length less than 6 m which are fitted with a full deck and quick-draining cockpit(s) complying with ISO 11812 may alternatively be assessed using ISO 12217-1 or ISO 12217-2 (for non-sailing and sailing boats, respectively), in which case higher design categories may be assigned.

In relation to habitable multihulls, this part of ISO 12217 includes assessment of susceptibility to inversion, definition of viable means of escape and requirements for inverted flotation.

This part of ISO 12217 excludes:

- inflatable and rigid-inflatable boats covered by ISO 6185, except for references made in ISO 6185 to specific clauses of ISO 12217;
- personal watercraft covered by ISO 13590 and other similar powered craft;
- aquatic toys;
- canoes and kayaks;
- gondolas and pedalos;
- sailing surfboards;
- surfboards, including powered surfboards;
- hydrofoils, foil stabilized boats and hovercraft when not operating in the displacement mode; and
- submersibles.

**NOTE** Displacement mode means that the boat is only supported by hydrostatic forces.

It does not include or evaluate the effects on stability of towing, fishing, dredging or lifting operations, which need to be separately considered if appropriate.

## 2 Normative references

The following documents, in whole or in part, are normatively referenced in this document and are indispensable for its application. For dated references, only the edition cited applies. For undated references, the latest edition of the referenced document (including any amendments) applies.

ISO 2896:2001, *Rigid cellular plastics — Determination of water absorption*

ISO 3864-1, *Graphical symbols — Safety colours and safety signs — Part 1: Design principles for safety signs and safety markings*

ISO 8666, *Small craft — Principal data*

ISO 9093-1, *Small craft — Seacocks and through-hull fittings — Part 1: Metallic*

ISO 9093-2, *Small craft — Seacocks and through-hull fittings — Part 2: Non-metallic*

ISO 10240, *Small craft — Owner's manual*

ISO 11812, *Small craft — Watertight cockpits and quick-draining cockpits*

ISO 12216, *Small craft — Windows, portlights, hatches, deadlights and doors — Strength and watertightness requirements*

ISO 12217-1:2015, *Small craft — Stability and buoyancy assessment and categorization — Part 1: Non-sailing boats of hull length greater than or equal to 6 m*

ISO 12217-2:2015, *Small craft — Stability and buoyancy assessment and categorization — Part 2: Sailing boats of hull length greater than or equal to 6 m*

ISO 14946, *Small craft — Maximum load capacity*

ISO 15083, *Small craft — Bilge-pumping systems*

ISO 15085, *Small craft — Man-overboard prevention and recovery*

## 3 Terms and definitions

For the purposes of this document, the following terms and definitions apply.

NOTE The meanings of certain symbols used in the definitions are given in [Clause 4](#).

### 3.1 Primary

#### 3.1.1

##### **design category**

description of the sea and wind conditions for which a boat is assessed to be suitable

Note 1 to entry: See also [9.2](#).

#### 3.1.2

##### **recess**

volume open to the air that might retain water within the range of loading conditions and corresponding trims

EXAMPLE Cockpits, wells, open volumes or areas bounded by bulwarks or coamings.

Note 1 to entry: Cabins, shelters or lockers provided with closures according to the requirements of ISO 12216 are not recesses.

Note 2 to entry: Cockpits that are open aft to the sea are considered to be recesses. Flush decks without bulwarks or coamings are not recesses.

**3.1.3****quick-draining recess**

recess fulfilling all the requirements of ISO 11812 for “quick-draining cockpits and recesses”

Note 1 to entry: ISO 11812 contains requirements with which most sailing dinghies cannot comply.

Note 2 to entry: According to its characteristics, a cockpit may be considered to be quick-draining for one design category, but not for a higher category.

**3.1.4****watertight recess**

recess fulfilling all the requirements of ISO 11812 for “watertight cockpits and recesses”

Note 1 to entry: This term only implies requirements in respect of watertightness and sill heights, but not those for drainage.

**3.1.5****fully enclosed boat**

boat in which the horizontal projection of the sheerline area comprises any combination of:

- watertight deck and superstructure, and/or
- quick-draining recesses complying with ISO 11812, and/or
- watertight recesses complying with ISO 11812 with a combined volume of less than  $(L_H B_H F_M)/40$ , and

all closing appliances having their degree of watertightness in accordance with ISO 12216

Note 1 to entry: The size of recesses permitted for some boats of design category C is restricted by the requirements of [6.4](#).

**3.1.6****partially protected boat**

boat which does not fulfil the definition of a fully-enclosed boat and in which the plan projected area of decking, cabins, shelters, outboard engine wells or other rigid covers which are watertight from above according to ISO 12216 and which immediately shed water directly overboard (i.e. not via drains) and

- comprises at least one-third of the plan projected area of the sheerline, and
- includes all the area within  $L_H/3$  from the bow, and
- includes at least 100 mm inboard from the sheerline,

except that the area of any watertight recesses with a total volume of less than  $(L_H B_H F_M)/40$  may shed water via drains

Note 1 to entry: This is illustrated in [Figure 1](#).

Note 2 to entry: Outboard engine wells are considered to provide a covering suitable for this purpose.

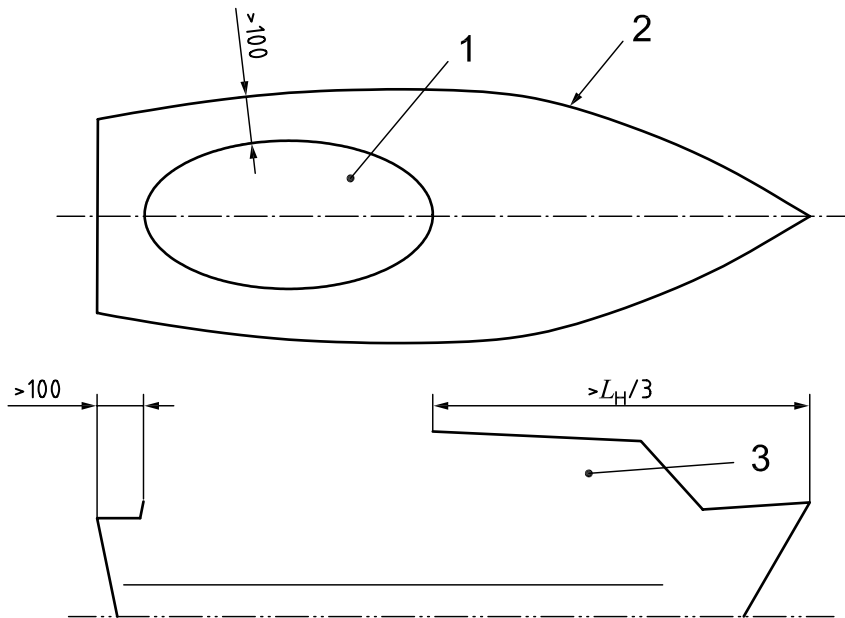

**Key**

- 1 recess area open from above (less than two-thirds of the total sheerline area)
- 2 sheerline
- 3 open shelter or enclosed cabin

**Figure 1 — Partially protected boat**

**3.1.7**

**habitable boat**

boat having a fully enclosed cabin with rigid roof fitted with one or more bunks, benches, pipecots, hammocks or similar locations that can be used for sleeping when the boat is under way

Note 1 to entry: A boat is considered to be “habitable” if a fabric closure is used instead of a rigid door, or the cabin has fabric sides.

Note 2 to entry: The following are not considered to render a boat “habitable”:

- a cockpit tent, or
- an open-sided cuddy intended to provide limited protection from spray, provided it is not fitted with fabric closures all round.

Note 3 to entry: Locations used for sleeping have minimum dimensions of 1,5 m diagonal length, 0,4 m width at the widest point, and with a minimum headroom of 0,4 m over the length. The cabin sole and compartments designated by the builder to be used exclusively for storage and referenced in the owner’s manual are not included.

**3.2 Downflooding**

**3.2.1**

**downflooding opening**

any opening in the hull or deck (including the edge of a recess) that might admit water into the interior or bilge of a boat, or a recess, apart from those excluded in [6.3.1.5](#)

**3.2.2****downflooding height** $h_D$ 

smallest height above the waterline to any downflooding opening (apart from those excluded in [6.3.1.5](#)) when the boat is upright in calm water in the maximum load condition, measured to the critical downflooding point which might be within pipes or ducts inside the hull

Note 1 to entry: Downflooding height is expressed in metres.

**3.2.3****downflooding angle** $\phi_D$ 

angle of heel at which the downflooding openings (apart from those excluded in [6.3.1.5](#)) become immersed, when the boat is in calm water and in the appropriate loading condition at design trim

Note 1 to entry: Downflooding angle may be determined using either of the methods in [Annex B](#).

Note 2 to entry: Where openings are not symmetrical about the centreline of the boat, the case resulting in the smallest angle is used.

Note 3 to entry: Downflooding angle is expressed in degrees.

**3.3 Condition and mass****3.3.1****empty craft condition**

empty boat including fittings and equipment as listed below but excluding all optional equipment and fittings not included in the manufacturer's basic outfit:

- a) structure: comprising all the structural parts, including any fixed ballast keel and/or drop keel/centreboard/daggerboard(s) and rudder(s);
- b) ballast: any fixed ballast installed;
- c) internal structure and accommodation: bulkheads and partitions, insulation, lining, built-in furniture, flotation material, windows, hatches and doors, permanently installed mattresses and upholstery materials;
- d) permanently installed engine(s) and fuel system: comprising inboard engine(s), including all supplies and controls as needed for their operation, permanently installed fuel systems, including tanks;
- e) fluids in permanently installed systems: residual working fluids as needed for their operation (see examples below), but excluding contents of fluid ballast systems and tanks, and main storage tanks which are included in maximum load;

EXAMPLES fluids in hot or cold water, fuel, lubricating or hydraulic oil systems.

- f) internal equipment: including:
  - all items of equipment permanently attached to the craft, e.g. tanks, toilet system(s), water transfer equipment;
  - bilge pumping system(s), cooking and heating devices, cooling equipment, ventilation system(s);
  - electrical installation and equipment, including permanently installed batteries mounted in the position intended by the builder;
  - fixed navigational and electronic equipment;
  - fixed fire fighting equipment, where fitted;

g) external equipment: including:

- all permanently attached standard or specified deck fittings, e.g. guardrails, pulpits and pushpits, bowsprits and their attachments, bathing platforms, boarding ladders, steering equipment, winches, sprayhood(s);
- awning(s), cockpit tables, gratings, signal mast(s), where fitted;
- mast(s), boom(s), standing and running rigging, in the stowed position ready for use; all standing and running rigging in place;

Note 1 to entry: The mass in the empty craft condition is denoted by  $m_{EC}$  and is expressed in kilograms.

### 3.3.2

#### **light craft condition**

empty craft condition plus standard equipment (3.4.10) plus removable ballast (whether solid or liquid) when supplied and/or intended by the manufacturer to be carried when the boat is afloat, with elements positioned as follows:

- a) where provision is made for propulsion by outboard engine(s) of more than 3 kW, the heaviest engine(s) recommended for the boat by the manufacturer, mounted in the working position(s);
- b) where batteries are fitted, they are mounted in the position intended by the builder, and if there is no specific stowage provided for batteries, the mass of one battery for each engine over 7 kW is allowed for, and located within 1,0 m of the engine location;
- c) all upwind sails supplied or recommended by the builder as standard, onboard and rigged ready for use, but not hoisted, e.g. mainsail on boom, roller furling sails furled, hanked foresails on stay stowed on foredeck

Note 1 to entry: For the minimum mass of outboard engines and batteries, refer to [Tables C.1](#) and [C.2](#).

Note 2 to entry: The mass in the light craft condition is denoted by  $m_{LC}$  and is expressed in kilograms.

### 3.3.3

#### **maximum load**

greatest load which the boat is designed to carry in addition to the light craft condition, comprising:

- the crew limit at 75 kg each (adult) or 37,5 kg (child);
- the personal effects of the crew;
- stores and cargo (if any), dry provisions, consumable liquids;
- contents of all permanently installed storage tanks filled to 95 % of their maximum capacity, including fuel, drinking water, black water, grey water, lubricating and hydraulic oil, bait tanks and/or live wells plus ballast water at 100 % capacity;
- consumable liquids in portable tanks (drinking water, fuel) filled to 95 % of the maximum capacity;
- dinghy or other small craft intended to be carried aboard, and any outboard motor associated with them;
- liferaft(s) if carried in excess of the minimum required in essential safety equipment;
- non-edible stores and equipment normally carried on the boat and not included in the manufacturer's list of standard equipment, e.g. loose internal equipment and tools, spare parts, additional anchors or sails, dinghy and outboard if carried aboard;
- an allowance for the maximum mass of optional equipment and fittings not included in the manufacturer's basic outfit

Note 1 to entry: Liferafts are not included in essential safety equipment for Categories C and D.



Note 2 to entry: As a guide, not less than 20 kg/person should be allowed for personal effects on habitable boats

Note 3 to entry: As a guide, the mass of yachting liferafts varies from approximately  $12 + 2CL$  (kg) to double this, according to specification.

Note 4 to entry: The mass of maximum load is denoted by  $m_L$  and is expressed in kilograms.

### 3.3.4 maximum load condition

boat in the light craft condition with the maximum load added so as to produce the design trim

Note 1 to entry: The mass in the maximum load condition is denoted by  $m_{L,DC}$  and is expressed in kilograms.

### 3.3.5 loaded arrival condition

boat in the maximum load condition minus 85 % of the maximum capacity of fixed or portable storage tanks for fuel, oils and drinking water, and minus 90 % of edible stores, but including the worst combination of optional fittings or equipment with respect to stability

Note 1 to entry: In this condition, tanks have 10 % of their maximum capacity remaining.

Note 2 to entry: The mass in the loaded arrival condition is denoted by  $m_{LA}$  and is expressed in kilograms.

## 3.4 Other definitions

### 3.4.1

#### crew

collective description of all persons on board a boat

### 3.4.2

#### crew limit

#### CL

maximum number of persons (with a mass of 75 kg each) used when assessing the design category

Note 1 to entry: A half number denotes a child weighing less than 37,5 kg.

### 3.4.3

#### design trim

longitudinal attitude of a boat when upright, with crew, fluids, stores and equipment in the positions designated by the designer or builder

Note 1 to entry: Crew are assumed to be in positions designated by the builder. In the absence of builder's instructions, crew and gear are assumed to be positioned in a manner most likely to provide a favourable test result, provided that such positions are consistent with the proper operation of the boat and that crew are assumed to be either standing at designated positions fitted with handholds, or seated.

### 3.4.4

#### essential safety equipment

loose equipment considered essential to the safe operation of the boat, which may include distress flares and rockets, lifebuoy with light and battery, first aid box, wire cutters for standing rigging, lifejackets, safety harnesses and lines, portable fire fighting equipment, flashlight, binoculars, radio (e.g. VHF), ball and cone visual signals, charts and navigational publications in the corresponding design category

Note 1 to entry: Quantities carried may vary according to the size of boat, design category and crew limit.

Note 2 to entry: As a guide, the mass allowed for essential safety equipment but excluding any liferaft(s) should not be less than  $3L_H$  (kg).

Note 3 to entry: Liferafts are not considered to be essential safety equipment in design categories C and D.

**3.4.5**

**flotation element**

element which provides “buoyancy” to the boat and thus influences the flotation characteristics

**3.4.5.1**

**air tank**

tank made of hull construction material, and integral with hull or deck structure

**3.4.5.2**

**air container**

container made of stiff material, and not integral with the hull or deck structure

**3.4.5.3**

**low density material**

material with a specific gravity of less than 1,0 primarily incorporated into the boat to enhance the buoyancy when swamped

**3.4.5.4**

**rib collar**

heavy duty tubular collar fitted around the periphery of the boat and always intended to be inflated whenever the boat is being used

**3.4.5.5**

**inflated bag**

bag made of flexible material, not integral with hull or deck, accessible for visual inspection and intended always to be inflated when the boat is being used

Note 1 to entry: Bags intended to be inflated automatically when immersed (e.g. at the masthead as a means to prevent inversion) are not regarded as flotation elements.

**3.4.6**

**length of hull**

$L_H$

length of the hull measured according to ISO 8666

Note 1 to entry: Length of hull is expressed in metres.

**3.4.7**

**loaded waterline**

waterline of the boat when upright in the maximum load condition

**3.4.8**

**reference sail area**

$A_S$

actual profile area of sails set abaft a mast, plus the maximum profile area of all masts, plus reference triangle area(s) forward of each mast as defined in ISO 8666

Note 1 to entry: Sail area is expressed in square metres.

**3.4.9**

**recess retention level**

level of water in recesses, when the boat is at design trim, at which 20% of the uppermost periphery of the surrounding coaming (measured in horizontal plane parallel to waterline at design trim) would be covered by water, assuming that all gates, doors or drainage openings are considered to be sealed.

Note 1 to entry: This definition is illustrated in [Annex I](#).



**3.4.10****standard equipment**

devices including outboard motors (excluding those for tenders), loose furniture and furnishings such as tables, chairs, non-permanently installed mattresses, curtains, etc., portable bilge pumping equipment, anchors, chain, warps, sails, loose external equipment such as fenders, boathook and boarding ladder, oars (if appropriate), and essential safety equipment

Note 1 to entry: Where outboard engine(s) are fitted, the heaviest engine(s) recommended for the boat by the manufacturer is(are) included, the mass allowed for outboard engines and their batteries (if not permanently installed) not being less than that given in columns 1 and 3 of [Tables C.1](#) and [C.2](#).

Note 2 to entry: As a guide, the mass allowed for anchors, anchor chain, warps and fenders should not be less than about  $0,25L_H^{2,2}$  (kg). In some cases up to double this mass may be appropriate.

**3.4.11****watertightness degree**

degree of watertightness as specified in ISO 11812 and ISO 12216

Note 1 to entry: The degree of watertightness is summarized as follows.

Degree 1: Degree of tightness providing protection against effects of continuous immersion in water.

Degree 2: Degree of tightness providing protection against effects of temporary immersion in water.

Degree 3: Degree of tightness providing protection against splashing water.

Degree 4: Degree of tightness providing protection against water drops falling at an angle of up to 15° from the vertical.

**3.4.12****windage area**

$A_{LV}$

projected profile area of hull, superstructures, deckhouses, outboard motors and spars above the waterline at the appropriate loading condition, the boat being upright

Note 1 to entry: Canopies and screens that can be erected when under way in bad weather are included, e.g. cockpit dodgers, pram hoods.

Note 2 to entry: Windage area is expressed in square metres.

**3.4.13****angle of vanishing stability**

$\phi_V$

angle of heel nearest the upright (other than upright) in the appropriate loading condition at which the transverse stability righting moment is zero; determined assuming that there is no offset load, and that all potential downflooding openings are assumed to be watertight

Note 1 to entry: Where a boat has recesses which are not quick-draining,  $\phi_V$  is to be taken as the downflooding angle to these recesses, unless the loss of buoyancy due to such recesses is fully accounted for in determining  $\phi_V$ .

Note 2 to entry: Angle of vanishing stability is expressed in degrees.

**3.4.14****under way**

not at anchor, or made fast to the shore, or aground

**4 Symbols**

For the purposes of this part of ISO 12217, the symbols in [Table 1](#) apply.

Table 1 — Symbols

Symbol	Unit	Meaning
$\phi$	degree (°)	Angle of heel
$\phi_D$	degree (°)	Downflooding angle, see <a href="#">3.2.3</a>
$\phi_O$	degree (°)	Angle of heel measured during offset-load test, see <a href="#">6.5</a>
$\phi_V$	degree (°)	Angle of vanishing stability, see <a href="#">3.4.13</a>
$A_{LV}$	m <sup>2</sup>	Windage area of hull in profile at the appropriate loading condition, see <a href="#">3.4.12</a>
$A_S$	m <sup>2</sup>	Reference sail area, see <a href="#">3.4.8</a>
$A'_S$	m <sup>2</sup>	Standard sail area, see <a href="#">7.7.2.4</a>
$B_H$	m	Beam of hull measured according to ISO 8666
$B_{WL}$	m	Beam waterline according to ISO 8666 on the loaded waterline. In the case of multi-hulls, this is the sum of the maximum waterline beam of each of the hulls
CL	—	Crew limit according to <a href="#">3.4.2</a>
$F_M$	m	Freeboard amidships to the loaded waterline according to ISO 8666
$h_D$	m	Actual downflooding height measured according to <a href="#">3.2.2</a> and <a href="#">6.3.2</a>
$h_{D(R)}$	m	Required downflooding height according to <a href="#">6.3.2</a>
$L_H$	m	Length of hull measured according to ISO 8666
$L_{WL}$	m	Length waterline in relevant load condition measured according to ISO 8666
$m_{EC}$	kg	Mass of the boat in the empty craft condition, see <a href="#">3.3.1</a>
$m_L$	kg	Mass of the maximum load, see <a href="#">3.3.3</a>
$m_{LA}$	kg	Mass of the boat in the loaded arrival condition, see <a href="#">3.3.5</a>
$m_{LC}$	kg	Mass of the boat in light craft condition, see <a href="#">3.3.2</a>
$m_{LDC}$	kg	Mass of the boat in the maximum load condition, see <a href="#">3.3.4</a>

## 5 Procedure

### 5.1 Maximum load

Decide on the crew limit and the maximum load that the boat is intended to carry in accordance with the definitions. The crew limit shall not exceed that determined by the seating or standing space requirements of ISO 14946.

**IMPORTANT — Ensure that the maximum load is not underestimated.**

NOTE If a boat is assessed with different amounts of maximum load, different design categories may be assigned according to the load.

### 5.2 Sailing or non-sailing

Determine whether the boat is sailing or non-sailing. Non-sailing boats are those where

$$A_S < 0,07 \times (m_{LDC})^{2/3} \quad (1)$$

where

$A_S$  is the reference sail area according to [3.4.8](#), expressed in square metres;

$m_{LDC}$  is the mass of the boat in the maximum load condition, as defined in [3.3.4](#) and expressed in kilograms.

All other boats are sailing boats. [Table 2](#) gives values of reference sail area for different maximum load condition masses.

**Table 2 — Minimum reference sail area for sailing boats**

$m_{LDC}$ (kg)	200	300	400	500	600	700	800	900	1 000	1 100	1 200	1 500
$A_S$ (m <sup>2</sup> ) shall be $\geq$	2,4	3,1	3,8	4,4	5,0	5,5	6,0	6,5	7,0	7,5	7,9	9,2

### 5.3 Tests to be applied

#### 5.3.1 General

**5.3.1.1** Non-sailing boats shall be assessed using [Clause 6](#) and [5.3.1.2](#) (if appropriate).

Sailing boats other than habitable multihulls shall be assessed using [Clause 7](#). Habitable multihull sailing boats shall be assessed using ISO 12217-2. For habitable non-sailing multihulls see [6.2](#) below.

NOTE 1 A habitable boat is defined in [3.1.7](#).

NOTE 2 For any given test, the requirements may vary according to the chosen option, e.g. for downflooding height.

**5.3.1.2** If a sailing boat can also be used as a non-sailing boat, e.g. with oars or engine, it shall also generally be assessed as a non-sailing boat, see also [7.1](#). The design category finally given is that for which the boat satisfies all the relevant requirements. See [Annex G](#).

NOTE 1 Boats may be given different crew limits and/or design categories according to whether they are being used as sailing or non-sailing boats.

NOTE 2 Attention is drawn to option 3 in [Table 3](#), which may be appropriate in some cases.

**5.3.1.3** If a sailing boat also used as a non-sailing boat has been assessed using options 7, 8 or 9 of [Table 7](#), if it is unable to pass any non-sail test then the boat is deemed to be acceptable if the safety sign given in [Figure 8](#) is displayed in a prominent position. When this sign is fitted, it shall comply with [Clause 8](#).

### 5.4 Alternatives

If the boat does not reach the desired design category, modify the maximum load and/or the number of crew and repeat the assessment.

Boats which are fully enclosed may alternatively be assessed using ISO 12217-1 or ISO 12217-2, for non-sailing and sailing boats respectively, in which case they may be able to attain design category A or B.

### 5.5 Variation in input parameters

Users of this part of ISO 12217 shall consider the effect on compliance of variations in the empty craft mass within the builder's manufacturing tolerances.

## 6 Tests to be applied to non-sailing boats

### 6.1 General

Non-sailing boats may be assessed by any one of six options according to length of hull, amount of flotation and decking, and whether the boat is fitted with suitable recesses complying with ISO 11812. These options and the corresponding tests to be applied are given in [Table 3](#).

NOTE For any given test, the requirements may vary according to the chosen option, e.g. for downflooding height.

The design category finally given in respect of stability and buoyancy is that for which the boat satisfies all the relevant requirements.

Fully enclosed boats may alternatively be assessed using ISO 12217-1, in which case higher design categories may be assigned.

Where boats are fitted with a bow loading ramp then either the bow ramp must be watertight to degree 2 (see [3.4.11](#)) or the boat must comply with this part of ISO 12217 when the bow ramp is open.

**Table 3 — Tests to be applied to non-sailing boats**

Option	1 <sup>a</sup>	2	3 <sup>a</sup>	4	5	6 <sup>a</sup>
Applicable to	$L_H < 6,0$ m			$L_H \geq 4,8$ m and $L_H < 6,0$ m		
Design categories possible	C and D	C and D	D	C and D	D	C and D
Applicable to engine powers of	Any amount	Any amount	$\leq 3$ kW	Any amount	Any amount	Any amount
Applicable to the following types of engine installation	Any	Any	Any	Any	Any	Inboard engines only
Decking or covering	All boats except “fully enclosed” <sup>b</sup>	Fully enclosed <sup>c</sup>	All boats except “fully enclosed” <sup>b</sup>	Partially protected <sup>d</sup>	All boats except “fully enclosed” <sup>b</sup>	All boats except “fully enclosed” <sup>b</sup>
Downflooding-height test	<a href="#">6.3</a> <sup>e</sup>	<a href="#">6.3</a>	—	<a href="#">6.3</a>	<a href="#">6.3</a>	<a href="#">6.3</a>
Recess size	—	<a href="#">6.4</a> <sup>f</sup>	—	—	—	—
Offset-load test	<a href="#">6.5</a>	<a href="#">6.5</a>	—	<a href="#">6.5</a>	<a href="#">6.5</a>	<a href="#">6.5</a>
Heel due to wind action	<a href="#">6.6</a> <sup>g</sup>	<a href="#">6.6</a> <sup>g</sup>	<a href="#">6.6</a> <sup>g</sup>	<a href="#">6.6</a> <sup>g</sup>	<a href="#">6.6</a> <sup>g</sup>	<a href="#">6.6</a> <sup>g</sup>
Flotation standard	Level	—	See <a href="#">6.9</a>	—	—	Basic
Flotation test	<a href="#">6.7</a>	—	See <a href="#">6.9</a>	—	—	<a href="#">6.8</a>
Flotation elements	<a href="#">Annex D</a>	—	<a href="#">Annex D</a>	—	—	<a href="#">Annex D</a>
Capsize-recovery test	—	—	<a href="#">6.9</a>	—	—	—
Detection and removal of water	<a href="#">6.10</a>	<a href="#">6.10</a>	<a href="#">6.10</a>	<a href="#">6.10</a>	<a href="#">6.10</a>	<a href="#">6.10</a>

<sup>a</sup> Boats using options 1, 3 and 6 are considered to be susceptible to swamping when used in their design category.

<sup>b</sup> That is, any boat that is not “fully enclosed”, thus including boats without any decking.

<sup>c</sup> This term is defined in [3.1.5](#). Option 2 boats may alternatively be assessed using ISO 12217-1.

<sup>d</sup> This term is defined in [3.1.6](#).

<sup>e</sup> The downflooding height test is not required on some boats – see [6.3.2.1](#).

<sup>f</sup> This requirement only applies to design category C.

<sup>g</sup> The application of [6.6](#) is only required for boats where  $A_{LV}$  in the condition used for the offset-load test  $\geq 0,5L_H B_H$ .

## 6.2 Habitable non-sailing multihull boats

**6.2.1** Habitable non-sailing multihull boats, if considered to be susceptible to inversion when used in their design category, in addition to [Clause 6](#) shall also comply with:

- a) the requirements for inverted buoyancy given in ISO 12217-2:2015, 7.12, and
- b) the requirements for escape after inversion given in ISO 12217-2:2015, 7.13.

NOTE A habitable boat is defined in [3.1.7](#).

**6.2.2** Boats of design category C are considered to be susceptible to inversion if:

$$h_C/B_H > 0,22V_D^{1/3} \quad (2)$$

where

$h_C$  is the height of the centroid of the above water profile area above the waterline in the light craft condition, in metres;

$V_D$  is the volume of displacement in the light craft condition, in cubic metres.

**6.2.3** Boats of design category D are considered not to be susceptible to inversion if they comply with [6.5](#) and [6.6](#).

## 6.3 Downflooding

NOTE These requirements are to ensure that a level of watertight integrity appropriate to the design category is maintained.

### 6.3.1 Requirements for downflooding openings

**6.3.1.1** All closing appliances (as defined in ISO 12216) such as windows, portlights, hatches, deadlights and doors shall comply with ISO 12216, according to design category and appliance location area.

Openings to centreboard or drop keel casings fitted to habitable sailing boats shall comply with watertightness degree 3 if their height is less than that corresponding to Area I.

**6.3.1.2** No hatches or opening type windows shall be fitted in the hull with the lowest part of the opening less than 0,2 m (design category C) or 0,1 m (design category D) above the loaded waterline, except for emergency escape hatches on design category C boats, where 0,1 m is allowable.

**6.3.1.3** Seacocks complying with ISO 9093-1 and ISO 9093-2, respectively, together with means of preventing flow into the boat when the seacock is open shall be fitted to through-hull pipe fittings located with any part of the opening below either the heeled or upright waterline when fully loaded, apart from:

- a) engine exhausts, or
- b) drains forming an integral part of the hull and of equal strength and tightness extending from the outlet to above the fully loaded upright waterline by at least 0,06 m for design category C or 0,04 m for design category D; and also above the heeled waterline defined as follows:
  - 1) 0° for non-sailing boats;
  - 2) 7° for sailing multihulls; or
  - 3) 30° or immersion of the sheerline, whichever occurs first, for monohull sailing boats.

NOTE 1 Means of preventing flow into the boat may comprise:

- a pipe or hose extending above the heeled waterline, or
- a pipe or hose leading to a downflooding point above the heeled waterline, or
- a non-return valve, or
- a pipe or hose connected to a system that cannot flood the interior of the boat, or
- for seacocks not connected internally, a permanent cap or means of securing the seacock in the closed position.

Instructions for the correct and safe operation of seacocks shall be included in the owner's manual.

NOTE 2 Special requirements for seacocks on bilge system discharges are given in ISO 15083.

**6.3.1.4** Openings within the boat, such as outboard engine trunks, free-flooding fish bait tanks or openings in centreboard casings, shall be considered as possible downflooding openings.

**6.3.1.5** The requirements given in [6.3.2](#) and [6.3.3](#) apply to all downflooding openings except:

- a) watertight recesses with a combined volume less than  $(L_H B_H F_M)/40$ , or quick-draining recesses;
- b) drains from:
  - quick-draining recesses, or
  - watertight recesses which, if filled, would not lead to downflooding or capsize when the boat is upright,

and which:

- 1) are freeing ports fitted with non-return flap closures which are watertight from the exterior to degree 3 of ISO 12216, or
  - 2) have a combined cross-sectional area smaller than three times the minimum area required to comply with ISO 11812 for quick-draining cockpits;
- c) non-opening appliances;
  - d) opening appliances located in the topsides which comply with ISO 12216 which are:
    - 1) referenced in the owner's manual as watertight closure to be kept shut when under way, and
    - 2) clearly marked on the inboard side "KEEP SHUT WHEN UNDER WAY" in upper case letters not less than 4,8 mm high, and
    - 3) positioned so that the lowest part of the opening is above the loaded waterline by at least 50 % of the minimum downflooding height required by [6.2.2](#) or in the case of means of escape fitted to habitable multihulls considered to be susceptible to inversion (see [6.2](#) and [7.1](#)) positioned with the bottom of the clear opening not less than 0,1 m above the loaded waterline when the boat is upright;
  - e) opening appliances which are fitted in a compartment of such restricted volume that, even if flooded, the boat satisfies all the requirements;
  - f) opening appliances located other than in the topsides which comply with ISO 12216 to tightness degree 2 and which are referenced in the owner's manual as being "KEEP SHUT WHEN UNDER WAY" and clearly marked as such on the appliance on the inboard side in upper case letters not less than 4,8 mm high;



- g) engine exhausts or other openings that are only connected to watertight systems;
- h) discharge pipes fitted with non-return valves;
- i) openings in the sides of outboard engine wells which are of
  - 1) watertightness degree 2 and having the lowest point of downflooding more than 0,1 m above the loaded waterline, or
  - 2) watertightness degree 3 and having the lowest point of downflooding more than 0,2 m above the loaded waterline and also above the top of the transom in way of the engine mounting, provided that well drain holes are fitted, see [Figure 2](#), or
  - 3) watertightness degree 4 and having the lowest point of downflooding more than 0,2 m above the loaded waterline and also above the top of the transom in way of the engine mounting, provided that well drain holes are fitted, and that the part of the interior or non-quick-draining spaces into which water may be admitted has a length less than  $L_H/6$  and from which water up to 0,2 m above the loaded waterline cannot drain into other parts of the interior or non-quick-draining spaces of the boat, see [Figure 2](#).

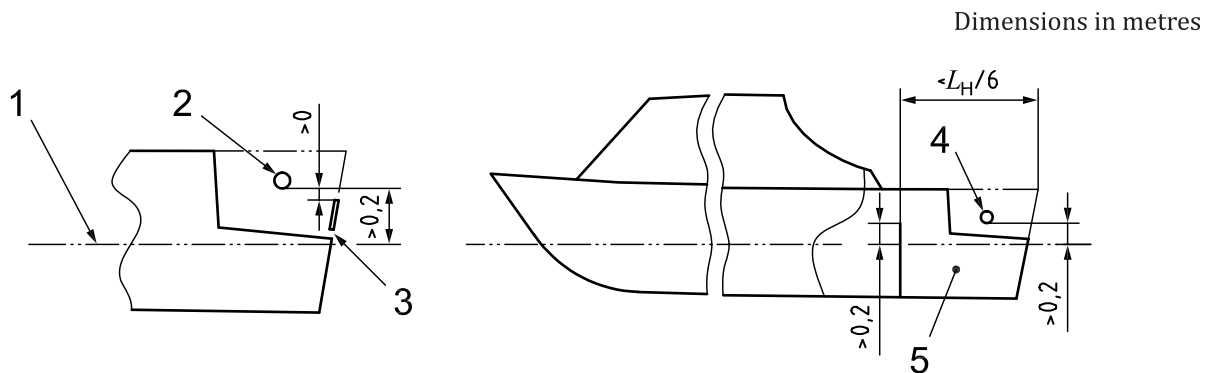

#### Key

- 1 waterline
- 2 watertightness degree 3 or 4
- 3 drain
- 4 watertightness degree 4
- 5 non-quick-draining space

**Figure 2 — Openings in outboard engine wells**

### 6.3.2 Downflooding height with maximum load

#### 6.3.2.1 Test

This test is to demonstrate sufficient margins of freeboard for the boat in the maximum load condition before water is shipped aboard.

The downflooding height test is not required to be conducted on the following boats:

- those which, when tested in accordance with [C.4.3](#), have been shown to support, in addition to the mass required by [C.2](#) and [Table C.5](#), in the same location an additional equivalent dry mass (kg) of  $(75CL + 10\%$  of the dry mass of stores and equipment included in the maximum total load), or
- those boats that do not take on water when heeled to  $90^\circ$  from the upright in the light craft condition.

## ISO 12217-3:2015(E)

This test shall be performed using people as described below, using test weights to represent people (at 75 kg per person), or by calculation (using a lines plan and displacement derived by a weighing or measured freeboards).

- a) Select a number of people equal to the crew limit, having an average mass of not less than 75 kg.
- b) In calm water, load the boat with all items of maximum load, with the people positioned so as to achieve the design trim.
- c) Measure the height from the waterline to the points at which water could first begin to enter any downflooding opening except those excluded in [6.3.1.5](#). Where a downflooding opening is fully protected by a higher coaming around the recess from which it leads, the downflooding height shall be measured to the lowest point of that coaming, see [Figure B.1](#). Where an opening in the hull is permanently attached to a watertight pipe or trunk rising to a higher level within the boat, the downflooding height is taken to the critical height within that pipe or trunk.

Downflooding height to downflooding points within quick-draining or watertight recesses shall be measured as though the following openings are closed:

- freeing ports fitted with non-return flap closures which are watertight from the exterior to degree 3 of ISO 12216, or
- drains having a combined cross-sectional area smaller than three times the minimum area required to comply with ISO 11812 for quick-draining cockpits.

### 6.3.2.2 Requirements

- a) Determine the design category by comparing the measurements with the requirements for minimum downflooding height, as modified by b) to f) below, using either
  - 1) the method of [Annex A](#), which generally gives the lowest requirement, or
  - 2) [Figure 3](#), which is based only on boat length.
- b) For boats assessed using options 1, 3, 5 or 6, the required downflooding height within  $L_H/3$  of the bow shall be increased as shown in [Figure 4](#).



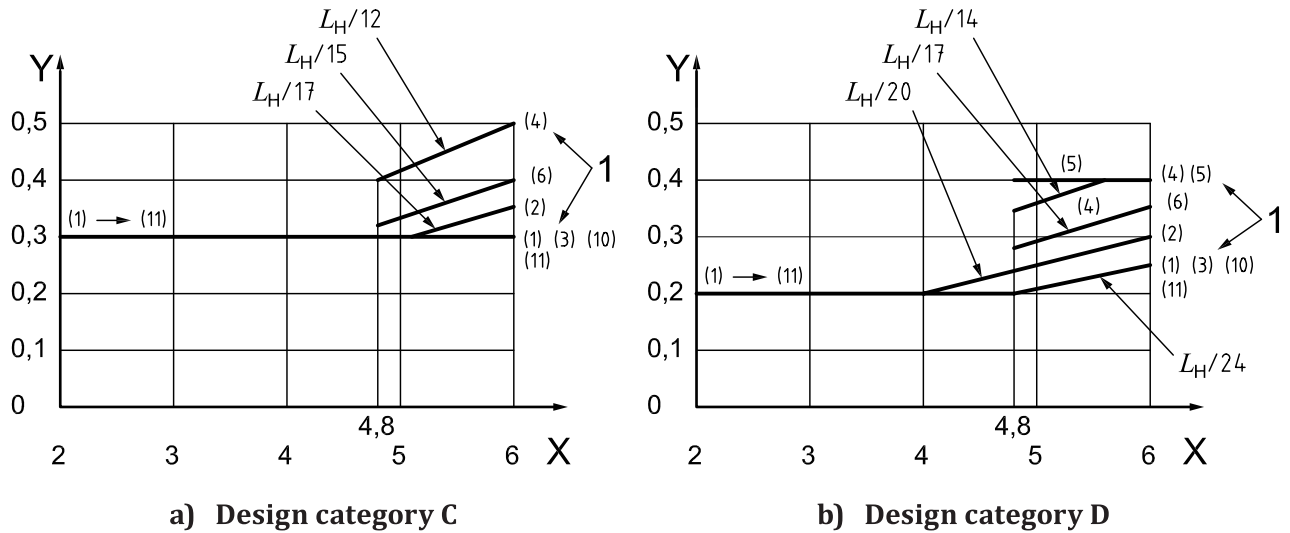

**Key**

- X length of hull (m)
- Y required downflooding height (m)
- 1 option numbers (see [Table 2](#))

**Figure 3 — Required downflooding height — design categories C and D**

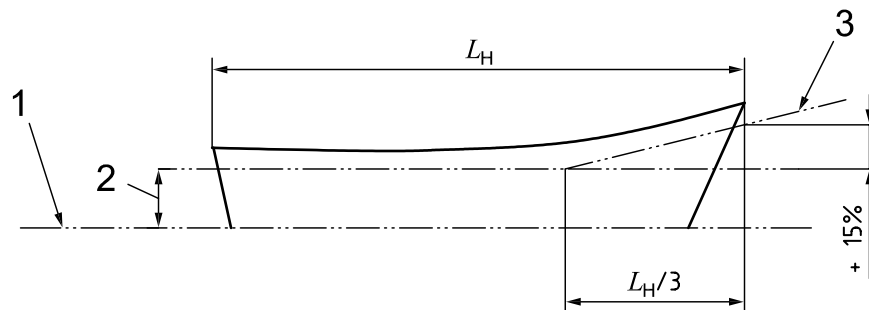

**Key**

- 1 waterline
- 2 basic downflooding requirement
- 3 increased requirement forward

**Figure 4 — Increase in required downflooding height — options 1, 3, 5 and 6 (see [Table 3](#))**

- c) Boats assessed using options 1, 3 or 5 are permitted a 20 % reduction in required downflooding height in the way of an outboard engine mounting position, provided that the width of this reduction is minimized.
- d) The required downflooding height at the transom shall be reduced by 0,05 m for boats of design category C using option 1, provided that such boats have a watertight recess aft (e.g. cockpit).
- e) Boats assessed using [Figure 3](#) shall be permitted downflooding openings having a combined clear area, expressed in square millimetres (mm<sup>2</sup>), of not more than (50L<sub>H</sub><sup>2</sup>) within the aft quarter of L<sub>H</sub> provided that the downflooding height to these openings is not less than 75 % of that required by [Figure 3](#).

- f) For sailing boats also equipped for use as non-sailing boats, the required downflooding height for centreboard, drop keel or dagger-board casings on the centreline shall be half of that determined by a) above.

### 6.3.3 Downflooding height — outboard boats when starting

In addition and only applicable to boats with provision for externally mounted outboard engine(s), the following requirements shall be satisfied.

- When the boat is in the light craft condition, with engine(s) fitted and one person of not less than 75 kg positioned 0,5 m forward of the engine attachment point, the least height from the waterline to the point at which the boat could first begin to enter any downflooding opening shall be greater than 0,1 m.
- The mass of petrol engines shall be taken from columns 1 and 3 of [Tables C.1](#) and [C.2](#) as appropriate to the maximum power recommended for the boat by the builder. For other engines, the mass of the actual engine shall be used.

## 6.4 Recess size

### 6.4.1 Application

This requirement is applicable only to fully enclosed boats of design category C for which the minimum freeboard to the recess coaming does not exceed  $L_H/10$ . The boat shall be assessed in the offset-load test condition. The requirements of either [6.4.2](#) or [6.4.3](#) shall be applied to recesses except those:

- a) fitted to boats with an angle of vanishing stability greater than  $90^\circ$ , or
- b) where the depth of the recess is less than 3 % of the maximum breadth of the recess over at least 35 % of the periphery, or  
EXAMPLE     Toe rails, low bulwarks.
- c) formed by a bulwark with at least 5 % of its area providing overboard drainage positioned within the lowest 25 % of its height and where the height of the bulwark is less than (the maximum breadth of the recess)/8, or
- d) where it can be shown that the unobstructed drainage area from the recess on each side of the boat centreline exceeds  $K \times$  (the volume of the recess to the recess retention level defined in [3.4.9](#)), where K is:
  - 0,09 where the drainage openings are within the lowest 25 % of the recess depth;
  - 0,16 where the drainage openings are within the lowest 50 % of the recess depth;
  - 0,30 where the drainage openings are the full depth of the recess.

To qualify under [6.4.1](#) c) and d):

- 1) the lower edge of all drainage openings shall be not more than 10 mm above recess sole height for at least 70 % of the width of each opening, and
- 2) where drainage area is provided by an open or partially open transom, openings shall extend to the outboard sides of the recess sole on both sides.

NOTE     The area of drainage openings is expressed in square metres and the volume is expressed in cubic metres.

Recesses completely or partially located within any third of the length must be considered to be swamped simultaneously.

Linked recesses shall be treated as being separate if more than 80 % of the volume of each one cannot drain into an adjacent linked recess. Where two recesses are linked by side decks, the total open cross-sectional area linking the forward and aft recesses must be greater than (open area at transom) × (volume of forward recess) / (volume of all linked recesses).

## 6.4.2 Simplified methods

**6.4.2.1** The percentage loss in initial metacentric height ( $GM_T$ ) due to free-surface effect when the recess is filled to the retention level defined in [3.4.9](#) and the boat is in the offset-load test condition shall be not more than

$$1\,200 F_R / L_H \quad (3)$$

for boats of design category C

where

$$F_R \quad \text{is the average freeboard to the waterline of the periphery of the recess} \\ = (F_A + 2F_S + F_F) / 4$$

where

- $F_A$  is the average of highest and lowest freeboard to the waterline across aft end of recess;
- $F_S$  is the average of highest and lowest freeboard to the waterline along the sides of recess;
- $F_F$  is the average of highest and lowest freeboard to the waterline across forward end of recess.

Compliance with this requirement may be demonstrated by any one of the methods given in [6.4.2.2](#), [6.4.2.3](#), or [6.4.2.4](#) for monohulls, or [6.4.2.2](#) or [6.4.2.3](#) for multihulls.

Alternatively, the direct calculation method of [6.4.3](#) may be used.

NOTE Each method given below is increasingly approximate, but in some cases [6.4.2.3](#) or [6.4.2.4](#) may be slightly more advantageous than [6.4.2.2](#).

**6.4.2.2** The percentage loss in initial metacentric height ( $GM_T$ ) due to free-surface effect may be calculated from:

$$\% \text{ loss } GM_T = \frac{102\,500 \times SMA_{\text{RECESS}}}{m_{LA} \times GM_T} \quad (4)$$

where

$SMA_{\text{RECESS}}$  is the second moment of area of free-surface of recess at retention level as defined in [3.4.9](#), about the longitudinal axis through the centre of area, expressed in  $m^4$ .

Where multiple recesses have to be considered swamped simultaneously,  $SMA_{\text{RECESS}}$  should include all such recesses.

**6.4.2.3** The percentage loss in initial metacentric height ( $GM_T$ ) due to free-surface effect may be estimated from:

$$\% \text{ loss GM}_T = \frac{245 \times \text{SMA}_{\text{RECESS}}}{\text{SMA}_{\text{WP}}} \quad (5)$$

where

$\text{SMA}_{\text{RECESS}}$  is the second moment of area of free-surface of recess at retention level as defined in [3.4.9](#);

$\text{SMA}_{\text{WP}}$  is the second moment of area of waterplane of boat at  $m_{\text{LA}}$ .

Both second moments of area are about the longitudinal axis through the respective centre of area, expressed in  $\text{m}^4$ .

Where multiple recesses have to be considered swamped simultaneously,  $\text{SMA}_{\text{RECESS}}$  should include all such recesses.

**6.4.2.4** The percentage loss in initial metacentric height ( $\text{GM}_T$ ) due to free-surface effect may alternatively be estimated more approximately, and therefore more conservatively, from:

$$\% \text{ loss GM}_T = 270 \left( \frac{l \times b^3}{L_H \times B_H^3} \right)^{0,7} \quad (6)$$

where

$l$  is the maximum length of recess at the retention level as defined in [3.4.9](#), expressed in metres;

$b$  is the maximum breadth of recess at the retention level as defined in [3.4.9](#), expressed in metres.

Where multiple recesses have to be considered swamped simultaneously,  $l$  shall be the sum of the length of individual recesses and  $b$  shall be the maximum value of any recesses considered swamped at the same time.

NOTE This method is not applicable to multihull boats.

### 6.4.3 Direct calculation method

For non-sailing boats, the direct calculation method of ISO 12217-1:2015, 6.5.3 may be used.

For sailing boats, the direct calculation method of ISO 12217-2:2015, 6.3.3 may be used.

## 6.5 Offset-load test

### 6.5.1 General

**6.5.1.1** This test is to demonstrate sufficient stability against offset loading by the crew, for unswamped boats. If it is more convenient, people may be used instead of test weights provided that the mass of each person used equals or exceeds that of the relevant test weight. Calculation of stability using a mass for the boat established by measurement may be used instead of a practical test. Testing shall be conducted in conditions of smooth water and light winds.

**6.5.1.2** Each boat shall be tested according to the offset-load test using either the simplified method in 6.5.2 or the full method in 6.5.3. The full method can be applied using either the physical test or the calculation method. The simplified method can only be applied by calculation.

If the mass in the light craft condition is less than 800 kg, the boat shall be also be tested according to the gunwale load test in 6.5.4.

NOTE The simplified method incorporates greater safety margins and is most suitable for boats with generous static stability in relation to the crew limit, e.g. those with a crew limit of less than one per metre length.

**6.5.1.3** All boats shall be tested in the maximum load condition, except that boats having any tank (fuel, fresh and black water, live wells, oils, etc.) that has a maximum transverse dimension greater than  $0,35 B_H$  shall be tested with all tanks as close as practicable to 50 % full, but never less than 25 % or more than 75 % full. Where application is by calculation, relevant tanks shall be assumed to be 50 % full and free-surface effect shall be represented either by a virtual increase in the VCG or by using a computer software that models the movement of fluid in tanks.

NOTE If tanks are linked by cross-connections that are kept open when the boat is in use, then the maximum transverse dimension of such tanks is measured between the extremes of the linked tanks.

**6.5.1.4** In general, boats shall be tested when heeled to both port and starboard. However, where it is clearly evident that one direction of heel is the most critical, only heel angles in this direction need be tested.

EXAMPLE Initial list and/or lower downflooding openings on one side and/or crew area clearly asymmetrical.

**6.5.1.5** During the tests, on boats with watertight or quick-draining cockpits, water may enter the cockpit through drains when the boat is heeled during the test, provided that this water drains overboard when the centre of gravity of all test weights on board are moved to the centreline. Where water enters the boat during the test, the heel angle and downflooding height measurements shall be recorded after the inflow of water has stopped.

**6.5.1.6** During the tests, the freeboard margin (remaining vertical height from the waterline) shall be measured to the point at which water could first begin to enter the interior or bilge. When measuring the freeboard margin, downflooding openings through the topsides should also be considered. When making such measurements one outboard engine well penetration fitted with a sealing boot may be regarded as watertight.

**6.5.1.7** The “crew area” comprises the “working deck” as defined by the manufacturer in accordance with ISO 15085 plus the areas of all seats, bunks, sunbathing pads, cabin soles and internal decks. It shall include all areas designated to be used by the crew when the boat is stationary, but can exclude ledges less than 0,10 m in width and areas excluded by “no access” signs.

NOTE 1 See ISO 15085:2003, 3.6, Note 3 for treatment of sloping surfaces.

If the manufacturer chooses to assess the stability by excluding some areas from the “crew area” or limiting the number of people on any given level:

- such areas shall be listed in the owner’s manual, and
- such areas shall be physically marked at all clearly defined points of access with “no access” or “limited access” signs as illustrated in Figures 5 and 6, or
- a diagram shall be placed at each helm position identifying such areas and their access limitations, see Figure 7, and in addition “no access” or “limited access” signs as illustrated in Figures 5 and 6 shall be placed at those points of access not visible from all alternative helm positions.

NOTE 2 In dinghies and open boats, the crew area comprises all the interior of the boat except for those areas excluded by “no access” signs. In dayboats it may be restricted to the cockpit provided that doing so still permits anchoring or mooring to be undertaken.

NOTE 3 In Figure 6 the number and the location should be adjusted as appropriate to the required restriction, e.g. coachroof, foredeck, flybridge.

When such safety signs are fitted, they shall comply with [Clause 8](#).

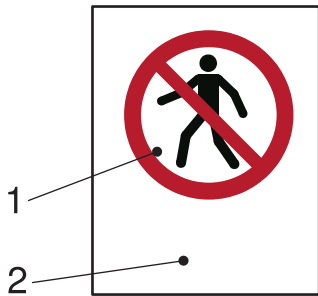

**Key**

- 1 sign P004 “No thoroughfare” from ISO 7010
- 2 supplementary text to read “No access”

**Figure 5 — No access sign**

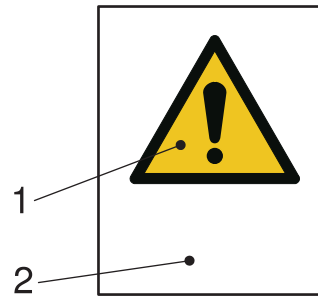

**Key**

- 1 sign W001 “General warning” from ISO 7010
- 2 supplementary text to read “Max *N* persons on (location)” where *N* is the relevant number and (location) is expressed for example as “flybridge” or “coachroof”

**Figure 6 — Limited access sign**

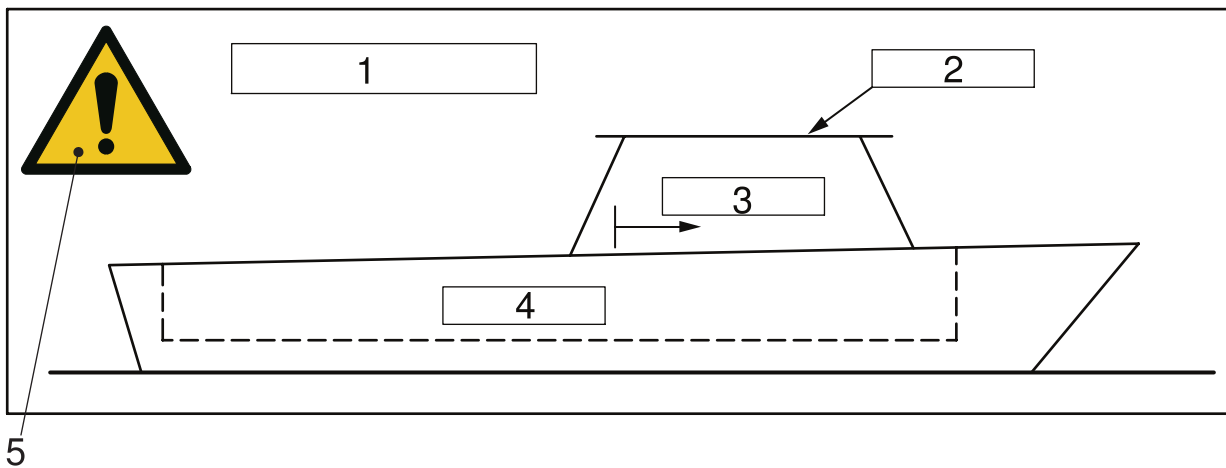

**Key**

- 1 text stating maximum total number of persons
- 2 text stating any access limitations such as “Do not sit or stand”
- 3 text stating any access limitations such as “Max persons on deck = 2”
- 4 text stating any access limitations such as “No restriction”
- 5 sign W001 “General warning” from ISO 7010

**Figure 7 — Example of crew area and access limitation sign for control position**

**6.5.2 Simplified procedure for offset-load test**

6.5.2.1 This method may only be applied by calculation.



**6.5.2.2** Calculate the mass and centre of gravity of the boat for two conditions (LC1 and LC2) as follows:

- boat in maximum load condition except for the tanks, which are to be treated as described in 6.5.1.3, and
- VCG of the crew used shall represent the maximum number permitted (at 85 kg each) on the highest part of the crew area (as defined in 6.5.1.7), for example: flybridge or coachroof top, located with their VCG 0,1 m above the seats, and the maximum number of the crew permitted (at 85 kg each) on each successively lower part of the crew area (e.g. wheelhouse, main deck or cockpit), located with their VCG 0,1 m above the seats, until the total number of persons equals the intended crew limit. Where there are no seats, the VCG of crew shall be located 0,1 m above the surface on which they stand. Where no persons limit is stated by the builder, the maximum number of persons on each level shall be one per seating place provided (at 500 mm wide) and not more than four per square metre of other areas.
- (LC1) LCG of the crew at 75 % of the maximum overall length of the crew area (as defined in 6.5.1.7) forward of its aft limit, and CG on the centreline.
- (LC2) LCG of the crew at 25 % of the maximum overall length of the crew area (as defined in 6.5.1.7) forward of its aft limit, and CG on the centreline.

The maximum overall length of the crew area is the simple longitudinal distance between the forward and aft extremities of the crew area. The lengths of different parts should not be added together.

**6.5.2.3** Calculate the curve of righting moments according to Annex E in ISO 12217-1:2015.

**6.5.2.4** Calculate the curve of crew heeling moments equal to  $961CL(B_C/2 - 0,2)\cos\phi$  (N·m), where  $B_C$  is the maximum transverse distance between the outboard extremities of any parts of the crew area as defined in 6.5.1.7, and  $\phi$  is the heel angle. Where the crew area includes side decks less than 0,4 m wide, the moment used shall be  $480CL B_C \cos\phi$  (N·m). Ledges less than 0,10 m wide may be excluded from the crew area.

**6.5.2.5** Plot righting moments and heeling moments on the same graph. The boat satisfies the test if:

- at the point of intersection of these curves the minimum heeled freeboard margin before downflooding is not less than required in Table 4, whether obvious to the crew (e.g. over the gunwale) or not obvious (e.g. through openings in the topsides); and
- at the point of intersection of these curves, except for category D boats that are not fully-enclosed, the heel angle (degrees),  $\phi_0$ , does not exceed

$$11,5 + \frac{(24 - L_H)^3}{520}, \tag{7}$$

see also Table 5.

- the maximum righting moment occurring up to the downflooding angle is greater than the heeling moment at the offset-load test heel angle,  $\phi_0$ .

**Table 4 — Required minimum heeled freeboard margin during offset-load test**

Dimensions in millimetres

Option	1	2	3	4	5	6
Design category C	100	100	Not applicable	150	Not applicable	100
Design category D	10	10	Not applicable	10	170	10

**Table 5 — Maximum permitted heel angle for offset-load test**

$L_H$ (m)	2,5	3,0	3,5	4,0	4,5	5,0	5,5	6,0
$\phi_{0(R)}$ (°)	30,6	29,3	28,1	26,9	25,8	24,7	23,7	22,7

**6.5.3 Full procedure for offset load-test**

**6.5.3.1** This method can be applied by either physical test or by calculation. Calculation shall replicate the physical test method described below or be calculated according to B.5.2 in ISO 12217-1:2015.

**6.5.3.2** Prepare a set of test weights totalling 85 kg for each person up to the desired crew limit. Then test the boat according to [6.5.3.3](#). A boat of design category D can alternatively be tested using [6.5.3.4](#).

NOTE 1 The use of water containers instead of metallic test weights will give a less advantageous result. The use of persons may give a less advantageous result but be more convenient to test.

NOTE 2 85 kg includes a margin of 13 % to allow for the probability that a group of persons may weigh on average more than 75 kg each.

Test weights totalling 98kg per person may be used, but the resulting test is more conservative.

NOTE 3 See [6.5.3.3](#) e) 3).

**6.5.3.3** The following procedure shall be followed.

- a) With the boat at maximum load condition except for the crew and except that the tanks are filled as in [6.5.1.3](#), place the first set of test weights to one side of the crew area but not closer than 200 mm from the outboard edge of the crew area, in the position that results in the maximum heel angle, investigating positioning test weights on various deck levels within the crew area and at various longitudinal locations to ensure that the worst case is found. Measure the heel angle and freeboard margin. Where the crew area includes side decks less than 0,4 m wide, test weights shall be placed at mid-width of such decks.
- b) If necessary, repeat in the opposite direction of heel. Where both directions are tested, the most adverse of the two measurements made of each parameter are to be recorded.
- c) Place the next set of test weights to one side of the crew area, in the position that results in the maximum heel angle, investigating positioning test weights on various deck levels within the crew area and at various longitudinal locations to ensure that the worst case is found. The centre of gravity of the sets of test weights shall be positioned as far to one side as practicable, provided that adjacent sets of test weights are not placed with their centres of gravity closer than 500 mm apart in any direction, or closer than 200 mm from the outboard edge of the crew area. Where the crew area includes side decks less than 0,4 m wide, test weights shall be placed at mid-width of such decks.
- d) Measure the heel angle and least freeboard margin. If necessary, repeat in the opposite direction of heel. Where both directions are tested, the most adverse of the two measurements made are to be recorded.
- e) Repeat c) and d) for further increments of not more than one set of test weights at a time, while observing the manufacturer’s definition of crew area according to [6.5.1.7](#). Stop the test when the first of the following events happens.
  - 1) The minimum freeboard margin before downflooding is reached according to [Table 4](#), whether obvious to the crew (e.g. over the gunwale) or not obvious to the crew (e.g. through downflooding openings in the topsides). This event can be ignored for boats employing this test and which comply with the total buoyant volume requirements of ISO 6185.
  - 2) Except for category D boats that are not fully-enclosed, the heel angle (degrees) is about to exceed



$$11,5 + \frac{(24 - L_H)^3}{520}, \quad (8)$$

see also [Table 5](#).

- 3) The total mass of test weights on board reaches 98 kg per person for the desired crew limit.

NOTE 98 kg per person is used here to ensure that a safety margin is achieved against sudden loss of stability.

- 4) The heel angle suddenly increases a large amount for a small increase in heeling moment. This is when the boat is close to a complete loss of residual stability and consequent capsize.

**CAUTION — Great caution must be exercised when doing this test because some boats may capsize suddenly. Therefore heeling moments should be increased carefully, especially when approaching the expected crew limit. As this point is approached, smaller increments of test weights should be used. In smaller boats it is helpful to attach a capsize preventer rope (e.g. from the depressed gunwale to a strong point ashore) provided that this is kept slack enough not to interfere with the test. For larger boats, to give warning of loss of stability, a continuously plotted graph of heel angle against heeling moment (product of the mass of test weights times the distance off the centreline measured parallel to the deck) should be used.**

**CAUTION — Because of the risk of capsize, persons should not be used instead of sets of test weights in any locations from which escape after capsize would be hazardous.**

- f) Of the measurements made according to a), b), d) or e), the maximum heel angle recorded shall be less than that required in e) above, and the minimum measured freeboard margin recorded shall exceed the requirement for the appropriate option as given in [Table 5](#).
- g) If the test is limited by downflooding that is obvious to the crew (e.g. over the gunwale), the crew limit corresponds to the maximum mass of test weights divided by 85 kg and rounded downward to the nearest whole or half number.
- h) If the test is limited by maximum heel angle, loss of stability or downflooding that is not obvious to the crew (e.g. through openings in the topsides), the crew limit corresponds to the maximum mass of test weights divided by 98 kg and rounded downward to the nearest whole or half number.

NOTE 1 98 kg per person is used here to ensure that a safety margin is achieved against sudden loss of stability.

NOTE 2 A half number denotes a child weighing less than 37,5 kg.

- i) After completion of testing according to a) to h), the sets of test weights are to be moved to the positions (using the criteria of c) above) that result in the least freeboard margin. If the measured freeboard does not satisfy [Table 5](#), sets of test weights shall be removed until this is achieved, while maintaining the most adverse positioning of the remainder.
- j) The final crew limit shall be that which complies with both the procedure described in a) to h), and that given in i) above.

When recording the heel angle of the boat, people engaged in measuring the heel angle shall return to the same position on board each time that measurements are recorded. Heeled freeboard margin shall be measured by a person not on board the boat being tested.

**6.5.3.4** Where a boat is unable to comply with the above test procedures, or where a safety sign is acceptable, it may alternatively be tested using the same procedure but with sets of test weights totalling  $85 \times L_H/6$  kg for each person up to the crew limit, provided that it is assigned design category D and a safety sign as shown in [Figure 8](#) is displayed in a prominent position. When this sign is fitted, it shall comply with [Clause 8](#).

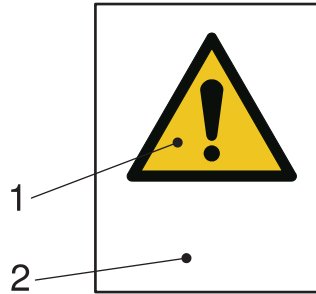

**Key**

- 1 sign W001 “General warning” from ISO 7010
- 2 supplementary text to read “Risk of capsizing or swamping”

**Figure 8 — Risk of capsizing or swamping sign**

**6.5.4 Procedure for gunwale load test**

**6.5.4.1** This test is only required if the mass in the light craft condition is less than 800 kg.

**6.5.4.2** Apply a vertically downwards load of 85 kg to the boat in the light craft condition at maximum beam, at the fore-and-aft location which is both a practical access point and which causes the greatest heel angle. If this load is applied by suspending a test weight in the water, the dry mass of the test weight must be  $85d$ , where  $d$  is a material coefficient as given in [Table 6](#).

NOTE 85 kg includes a margin of 13 % to allow for the probability that a person may weigh on average more than 75 kg.

**Table 6 — Material coefficient**

Property	Material				
	Lead	65/35 brass	Steel	Cast iron	Aluminium
Value of $d$	1,099	1,138	1,151	1,163	1,612

**6.5.4.3** If the boat swamps or capsizes under this load, it shall be restricted to design category D, and a warning label as shown in [Figure 9](#) shall be displayed where it is clearly visible when entering the boat. When this sign is fitted, it shall comply with [Clause 8](#).

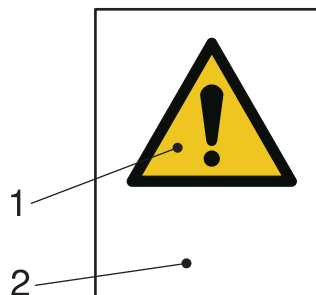

**Key**

- 1 sign W001 “General warning” from ISO 7010
- 2 supplementary text to read “Do not sit on gunwale”

**Figure 9 — “Do not sit on gunwale” sign**

## 6.6 Heel due to wind action

### 6.6.1 General

Boats shall be assessed in the loading condition used for the offset-load test (see [6.5.1](#)), assuming a mass of 85 kg for each person on board.

Boats of design categories C and D, where  $A_{LV} < 0,5L_H B_H$  in the offset-load test condition, do not have to be assessed. Other boats shall be assessed as follows.

### 6.6.2 Calculation

The heeling moment due to wind,  $M_W$ , expressed in newton metres, is assumed to be constant at all angles of heel and shall be calculated using either Formula 9 or Formula 10 below:

$$M_{W1} = 0,53 A_{LV} h v_W^2 \quad (9)$$

or

$$M_{W2} = 0,30 A_{LV} (A_{LV}/L_{WL} + T_M) v_W^2 \quad (10)$$

where

$h$  is the vertical distance between the geometric centres of  $A_{LV}$  and underwater profile area, expressed in metres;

$T_M$  is the draught at the mid-point of the waterline length, expressed in metres;

$v_W$  = 17 m/s for design category C, and 13 m/s for design category D;

$A_{LV}$  is the windage area as defined in [3.4.12](#), expressed in square metres;

$L_{WL}$  is the length on the waterline in the offset-load test condition, expressed in metres.

When assessing this criterion, righting moments shall take account of free-surface effects.

### 6.6.3 Requirement

The heel angle due to the wind heeling moment,  $\phi_W$ , shall be determined either:

- a) by comparing the heeling moment with the curve of righting moments, or
- b) by applying a static heeling moment equal to the wind heeling moment and measuring the resulting heel angle using the offset-load test data.

The angle  $\phi_W$  shall be less than 70 % of the maximum allowable heel angle in the offset-load test, derived from [6.5.2.5](#), and less than 70 % of the downflooding angle,  $\phi_D$ , determined using either of the methods of [Annex B](#).

## 6.7 Level flotation test

This test is to demonstrate adequate swamped buoyancy and stability.

The test shall be performed using the complete method given in [Annex C](#).

Where flotation elements are used, they shall comply with [Annex D](#).

The downflooding height test is not required to be conducted on the following boats:

- a) those which, when tested in accordance with [C.4.3](#), have been shown to support, in addition to the mass required by [C.2](#) and [Table C.5](#), in the same location an additional equivalent dry mass (kg) of (75CL + 10 % of the dry mass of stores and equipment included in the maximum total load); or
- b) those boats that do not take on water when heeled to 90° from the upright in the light craft condition.

## **6.8 Basic flotation test**

This test is to demonstrate that the boat has sufficient flotation to satisfy the swamped buoyancy load test of [C.4.3](#). It shall either be proven using the physical test method given in [C.2](#) and [C.4.3](#) or the calculation method of [Annex E](#) for the same condition and loading.

Where flotation elements are used, they shall comply with [Annex D](#).

In addition, the boat shall be fitted with some means, such as handholds, for persons in the water to maintain contact with the swamped boat.

## **6.9 Capsize-recovery test**

**6.9.1** This test is to demonstrate that a capsized boat can be returned to the upright by the actions of the crew using their body action and/or righting devices purposely designed and permanently fitted to the boat, that it will subsequently float, and to verify that the recommended minimum crew mass is sufficient for the recovery method used.

**6.9.2** Flotation material and elements used in boats employing this test shall comply with [Annex D](#).

**6.9.3** The test shall be conducted in calm conditions, with the boat in the light craft condition with loose equipment in the normal operating location, and air tanks, containers or bags having been tested in accordance with [Annex D](#).

**6.9.4** The boat shall be capsized to approximately 180° or the maximum practicably attainable equilibrium heel angle, with the crew in the water alongside. Sufficient depth of water shall be available to allow unimpeded movement of the boat. The boat shall not sink after floating in this manner for 5 min.

**6.9.5** The number and combined mass of the crew shall be the minimum suitable for the boat as recommended by the builder.

**6.9.6** The boat shall be righted by the crew without exploiting the sea bed or any external aid. No more than three attempts are permissible, each of which shall be limited to 5 min duration from commencement. Only one successful attempt is required.

**6.9.7** The following information shall be recorded for inclusion in the owner's manual:

- the likelihood of capsize when in normal use;
- the righting technique which is most successful;
- the minimum necessary crew mass, expressed in kilograms.

**NOTE** The likelihood of capsize may be expressed in terms similar to the following:

- "This boat should be used with great care if capsize is to be avoided."; or
- "Even if used with great care and skill, the design of this boat is such that capsize is always a possibility, even in light conditions."

**6.9.8** After the boat has been righted and one person with a mass of not less than 75 kg has reboarded, the boat shall float such that the residual freeboard would enable the boat to be pumped or bailed out. The longitudinal position of that person may be optimized to ensure sufficient residual freeboard for pumping or bailing.

**6.9.9** Without bailing the boat at all, after the remainder of the crew up to the crew limit have reboarded, the boat shall float approximately level with not more than one-third of the deck or gunwale submerged, for not less than 5 min.

**6.9.10** Boats passing the above test shall be given design category D, and shall be permanently marked in a prominent position with the safety sign shown in [Figure 8](#) and appropriate text added in the owner's manual – see [Annex F](#). The sign shall comply with [Clause 8](#).

## 6.10 Detection and removal of water

**6.10.1** The internal arrangement of a boat shall facilitate the drainage of water, either:

- to bilge suction point(s),
- to a location from which it may be bailed rapidly, or
- directly overboard.

**6.10.2** Boats shall be provided with means of removing water from the bilges in accordance with ISO 15083. The bilge pumping capacity (l/min) should reflect the degree of decking and consequent risk of water entering the boat.

**6.10.3** Design category C boats using option 4 or 6 shall be provided with means of detecting the presence of water in the bilge from the helm position, which shall comprise:

- direct visual inspection, or
- transparent inspection panels in interior mouldings, or
- bilge alarms, or
- indication of the operation of automatic bilge pumps, or
- other equivalent means.

**NOTE** Essential Requirement 3.5 of EU Directive 94/25/EC requires that all craft shall be designed so as to minimize the risk of sinking, and that particular attention should be paid where appropriate to:

- cockpits and wells, which should be self-draining or have other means of keeping water out of the boat interior,
- ventilation fittings,
- removal of water by pumps or other means.

## 7 Tests to be applied to sailing boats

### 7.1 General

Sailing boats other than habitable multihulls may be assessed by any one of five options according to amount of flotation and decking. These options and the tests to be applied are given in [Table 7](#).

**NOTE 1** For any given test, the requirements may vary according to the chosen option, e.g. for downflooding height.

Fully enclosed boats may alternatively be assessed using ISO 12217-2, in which case higher design categories may be assigned.

Habitable multihull sailing boats shall be assessed using ISO 12217-2.

If a sailing boat is also equipped for use as a non-sailing boat, e.g. for rowing or for engine propulsion, it shall also generally be assessed as a non-sailing boat, but boats may be given different crew limits and/or design categories according to whether they are being used as sailing or non-sailing boats.

NOTE 2 Attention is drawn to option 3 in [Table 3](#), which may be appropriate in some cases.

Sailing boats also used as a non-sailing boat and assessed using [7.5](#) or [7.6](#), but which are unable to comply with [Clause 6](#), are considered to be acceptable provided that they display the safety sign given in [Figure 8](#). When this sign is fitted, it shall comply with [Clause 8](#).

**Table 7 — Tests to be applied to sailing boats**

Option	7 <sup>a</sup>	8 <sup>a</sup>	9 <sup>a</sup>	10 <sup>b</sup>	11 <sup>b</sup>
Design categories possible	C and D	C and D	C and D	C and D	C and D
Applicable to hull types	All	Monohull only	Monohull only	Monohull only	Multihull only
Decking or covering	Any boat except “fully enclosed” <sup>c</sup>	Any boat except “fully enclosed” <sup>c</sup>	Any boat except “fully enclosed” <sup>c</sup>	Fully enclosed boat	Fully enclosed boat
Downflooding-height test	—	—	—	<a href="#">7.2</a>	<a href="#">7.2</a>
Recess size	—	—	—	<a href="#">7.3</a> <sup>d</sup>	<a href="#">7.3</a> <sup>d</sup>
Flotation requirement	(see <a href="#">7.5</a> )	Level (Cat. C) Basic (Cat. D)	Level (Cat. C) <sup>e</sup> Basic (Cat. D) <sup>e</sup>	—	<a href="#">7.8</a>
Flotation test	(see <a href="#">7.5</a> )	<a href="#">7.4</a>	<a href="#">7.4</a> <sup>e</sup>	—	—
Flotation elements	<a href="#">Annex D</a>	<a href="#">Annex D</a>	<a href="#">Annex D</a>	—	—
Capsize-recovery test	<a href="#">7.5</a>	—	—	—	—
Knockdown-recovery test	—	<a href="#">7.6</a>	—	<a href="#">7.6</a>	—
Wind stiffness test	—	—	<a href="#">7.7</a> <sup>f</sup>	—	<a href="#">7.7</a> <sup>fg</sup>
Detection and removal of water	<a href="#">6.10</a>	<a href="#">6.10</a>	<a href="#">6.10</a>	<a href="#">6.10</a>	<a href="#">6.10</a>
Apply requirements of Part 2	—	—	—	—	Category C only

<sup>a</sup> Boats using options 7, 8 and 9 that are not fully enclosed are considered to be susceptible to swamping when used in their design category, excepting those boats using option 9 and covered by the exemptions given in footnote e.

<sup>b</sup> Alternatively, boats may be assessed using ISO 12217-2.

<sup>c</sup> That is, any boat that is not “fully enclosed”, thus including boats without any decking.

<sup>d</sup> Only applicable to design category C.

<sup>e</sup> Flotation testing is not required for boats satisfying the exemptions given in [7.4.1](#) or [7.4.2](#).

<sup>f</sup> Only applicable to boats with  $m_{EC} > 300$  kg.

<sup>g</sup> Only applicable to design category D.

## 7.2 Downflooding

The downflooding requirements of [6.3](#) shall be satisfied. Tests may be conducted either by practical testing or by calculation. The tests shall be conducted in accordance with [6.3](#).



### 7.3 Recess size

Fully enclosed boats of design category C shall comply with the recess size limitations given in [6.4](#).

NOTE This clause does not apply to fully enclosed boats of design category D.

### 7.4 Flotation tests

#### 7.4.1 Level flotation test

The purpose of the level flotation test is to demonstrate adequate swamped buoyancy and stability.

Boats having  $L_H > 4,8$  m and  $m_{LC} > 150 L_H$  are exempt from this test provided that they are partially protected (as defined in [3.1.6](#)) with the undecked area comprising watertight recess(es) complying with ISO 11812, and provided that they comply with the wind stiffness test of [7.7](#) and satisfy the downflooding-height requirement of option 4 in [Table 3](#).

The test shall be performed using the complete method described in [Annex C](#).

Where flotation material or elements are used, they shall comply with [Annex D](#).

#### 7.4.2 Basic flotation test

The purpose of the basic flotation test is to demonstrate that the boat has sufficient swamped buoyancy.

Boats having  $L_H > 4,8$  m and  $m_{LC} > 150L_H$  are exempt from this test, provided they:

- are partially protected (as defined in [3.1.6](#)),
- comply with the wind stiffness test of [7.7](#), and
- satisfy the downflooding-height requirement of option 4 in [Table 3](#).

The test shall be performed using the physical test method given in [C.2](#) and [C.4.3](#) or the calculation method of [Annex E](#) for the same loading condition.

Where flotation material or elements are used, they shall comply with [Annex D](#).

### 7.5 Capsize-recovery test

**7.5.1** The capsize-recovery test shall be conducted in accordance with [6.9.1](#) to [6.9.9](#), with the following additional preparations:

- a) fore-and-aft sails shall be hoisted and set;
- b) centreboard(s) or keel(s) shall be lowered.

NOTE In applying [6.9.7](#) to a sailing boat, the likelihood of capsize may also be expressed in terms similar to the following:

- “This boat is very tolerant and if handled sensibly is most unlikely to capsize except in severe conditions.”; or
- “If sailed with care, this boat is unlikely to capsize in normal use provided that the sail area is adjusted to suit the prevailing conditions and the main sheet is not belayed.”
- “Even if sailed with great care and skill, the design of this boat is such that capsize is always a possibility, even in light conditions.”

**7.5.2** Boats passing the above test shall be given either design category C or D at the discretion of the builder, and shall be permanently marked in a prominent position with one of the safety signs shown in

Figure 10, and appropriate text added in the owner’s manual – see Annex F. Safety signs shall comply with Clause 8.

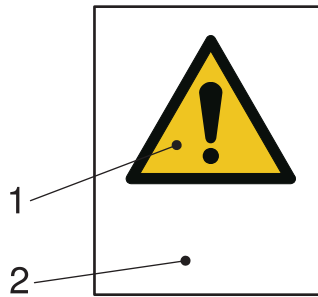

**Key**

- 1 sign W001 “General warning” from ISO 7010
- 2 supplementary text to read “Risk of capsizing!”

**a) Where there is no cabin**

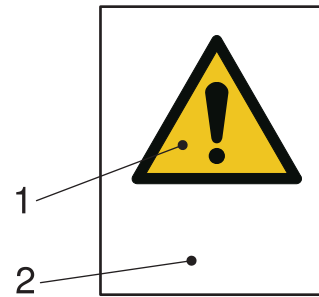

**Key**

- 1 sign W001 “General warning” from ISO 7010
- 2 supplementary text to read “Risk of capsizing! Persons in cabin may be trapped!”

**b) Where boat is fitted with a cabin**

**Figure 10 — Safety signs for capsizing recoverable boats**

**7.6 Knockdown recovery test**

**7.6.1** This test is to demonstrate that a boat can return to the upright unaided after being knocked down. Compliance may be demonstrated either by a physical test, or by calculation according to 7.6.5.

**7.6.2** This test shall be conducted in calm water, with the boat in the light craft condition with the addition of persons, loose water or another test weight to a total mass not less than that of the crew limit. The sails shall be lowered and stowed, and centreboard(s) or keel(s) raised unless they can be fixed in the lowered position and an appropriate instruction is given in the owner’s manual. If persons are used, they shall be positioned as shown in Figure 11 prior to release of the mast. If water or another weight is used, it shall be placed inside the hull. Water may not be used if it would not be retained when the boat is heeled as required by 7.6.3 or 7.6.4 below.

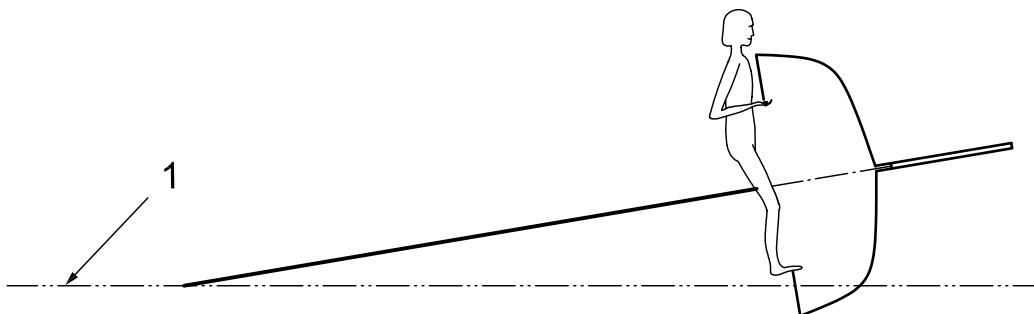

**Key**

- 1 waterline

**Figure 11 — Positioning of the crew (design category C test illustrated)**



**7.6.3** For design category C, the boat shall be quickly rotated until the masthead touches the water surface and shall then be released after 60 s. The boat may begin to flood, but this is acceptable provided the boat rapidly returns to a nearly upright position, and provided that the boat does not sink and that the residual freeboard would enable the boat to be pumped or bailed out. The longitudinal position of the crew may be optimized to ensure sufficient residual freeboard for pumping or bailing.

**7.6.4** For design category D, the boat shall be quickly rotated until the mast is horizontal and shall then be released after 10 s. The boat may begin to flood, but this is acceptable provided the boat rapidly returns to a nearly upright position, and provided the boat does not sink and that the residual freeboard would enable the boat to be pumped or bailed out. The longitudinal position of the crew may be optimized to ensure sufficient residual freeboard for pumping or bailing.

**7.6.5** Calculation to show that the righting moment is positive at the initial angle of heel may be used instead of a practical test, provided it is assumed that the main access hatchway to cabins is fully open, and that water enters any spaces subject to downflooding.

**7.6.6** If the downflooding characteristics are not the same port and starboard, the test shall be conducted in the most critical direction. When this is unclear, it shall be conducted in both directions.

## 7.7 Wind stiffness test

### 7.7.1 General

This test is to demonstrate that, when a sailing boat is heeled to a steady wind speed appropriate to the design category, the boat does not start flooding. It shall not be applied to boats with  $m_{EC} < 300$  kg.

Compliance may be demonstrated either by practical test (see [7.7.2](#)), or by calculation (see [7.7.3](#)).

### 7.7.2 Practical test

**7.7.2.1** With the boat in the light craft condition, place a person or a weight with a mass of 75 kg on the centreline on the cockpit sole to represent one crew member situated within reach of the helm. Sails shall be stowed ready for hoisting, and centreboard(s) or keel(s) raised unless they can be fixed in the lowered position and an appropriate instruction is given in the owner's manual.

**7.7.2.2** Apply a heeling couple to the boat, for example using either of the arrangements shown in Figure 12 and taking care to keep the two lines parallel, until the first of the following occurs:

- the boat begins to fill with water; or
- the load  $T$  and the corresponding heel angle meet those for the desired wind speed; or
- the boat reaches 45° heel; or
- for catamarans the underside of one hull begins to emerge, or
- for trimarans the deck of one sidehull begins to become submerged or the centre hull begins to emerge, whichever occurs sooner.

NOTE 1 For the purposes of this test, the mast may be fitted with temporary reinforcing or staying. The use of twin underwater restraint lines located forward and abaft the mast will minimize any tendency of the boat to yaw.

NOTE 2 Figure 12 shows two alternative ways of arranging the lines. Tension  $T_1$  should be used in conjunction with lever  $h_1$  and  $T_2$  should be used in conjunction with lever  $h_2$ .

**7.7.2.3** Determine the lever height  $h$ , in metres, the tension  $T$ , in kilograms, and the heel angle  $\phi_T$ , in degrees.

7.7.2.4 Calculate the steady wind speed, in metres per second, needed to produce this heel angle as follows:

$$\text{Calculated wind speed (m/s)} = \sqrt{\frac{13hT + 390B_H}{A'_S (h'_{CE} + h_{LP}) (\cos \phi_T)^{1,3}}} \quad (11)$$

where

$A'_S$  is the actual profile area of the largest sail plan suitable for windward sailing in a true wind speed of 10 kn to 12 kn (5,1 m/s to 6,2 m/s), including overlaps, and supplied or recommended by the manufacturer as standard, expressed in square metres;

$h'_{CE}$  is the height of the geometrical centre of  $A'_S$  above the waterline when upright, expressed in metres;

$h_{LP}$  is the height of the waterline above the geometrical centre of the lateral profile area of the immersed hull and keel(s)/centreboard(s) and rudder(s), when upright, expressed in metres.

NOTE  $h'_{CE}$  and  $h_{LP}$  are illustrated in Figure 13.

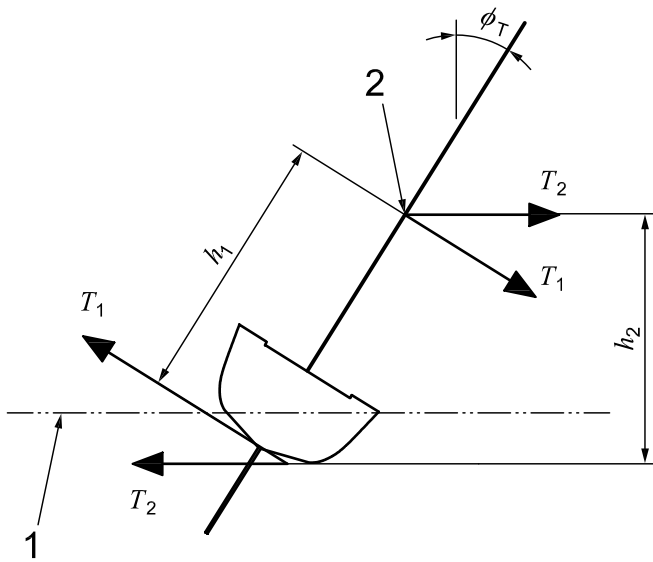

Key

- 1 waterline
- 2 any convenient location

Figure 12 — Wind stiffness test

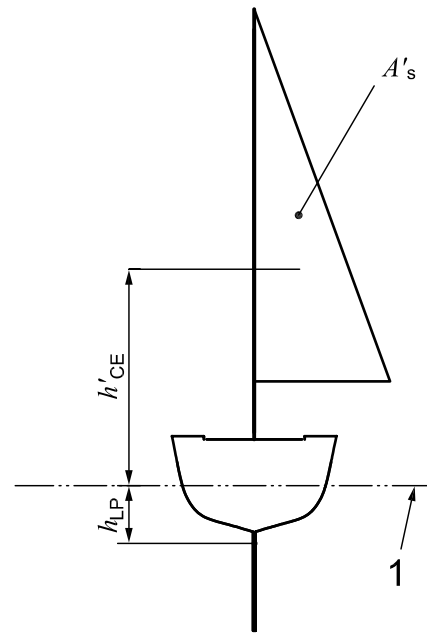

Key

- 1 waterline

Figure 13 — Dimensions  $h'_{CE}$  and  $h_{LP}$

### 7.7.3 Compliance by calculation

7.7.3.1 Calculate the curve of righting moments of the hull (in newton metres) when loaded with one crew member of 75 kg on the centreline.

7.7.3.2 To allow for one crew seated to windward, increase this curve by  $294B_H \cos \phi$ , (N·m).

**7.7.3.3** Calculate the wind heeling moment curve for the minimum wind speed for the intended design category (see [7.7.4.1](#) below), from:

$$0,75 v_W^2 A'_S (h'_{CE} + h_{LP}) (\cos \phi)^{1,3} \text{ (N}\cdot\text{m)} \quad (12)$$

where

$v_W$  is the wind speed, expressed in metres per second.

**7.7.3.4** The boat complies if the curves intersect at a heel angle of less than the downflooding angle or 45° if this is less. To achieve compliance, a reefed sail plan may be assumed, see [7.7.4.2](#).

**7.7.3.5** All the requirements of [7.7.4](#) shall be satisfied.

#### **7.7.4 Requirements**

**7.7.4.1** The boat shall be given design category D if the calculated wind speed is 6 m/s or more, and design category C if it is 11 m/s or more.

**7.7.4.2** If the boat is unable to satisfy the requirements of [7.7.4.1](#) with full sail, it may be given design category C or D if these requirements are satisfied when reefed provided that the reefed sail area is not less than two-thirds of  $A'_S$  as defined in [7.7.2.4](#).

**7.7.4.3** The owner's manual shall clearly state the apparent wind speed at which reefing becomes necessary, and the possible consequences of failing to reef at the appropriate time. The wind speed given shall correspond to that at which the largest sail plan suitable for windward sailing in a wind speed of 10 kn to 12 kn (5,1 m/s to 6,2 m/s), including overlaps, and supplied or recommended by the manufacturer as standard, is required to be reefed in accordance with [7.7.2.4](#), or [7.7.4.2](#) above.

**NOTE** The consequences of failing to reef at the appropriate time may be expressed in terms similar to the following:

**IMPORTANT** — "If not sailed with care, this boat may swamp or capsize unless the sail area is adjusted to suit the prevailing wind conditions and the main sheet is not belayed."

7.7.4.4 All boats assessed using this test shall prominently display at the main control position one of the safety signs given in [Figure 14](#). Safety signs shall comply with [Clause 8](#).

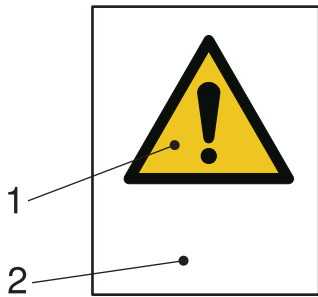

**Key**

- 1 sign W001 “General warning” from ISO 7010
- 2 supplementary text to read “Reef sails at *N* knots (or m/s) apparent wind speed”, where *N* is the relevant wind speed

**a) Fully enclosed boats**

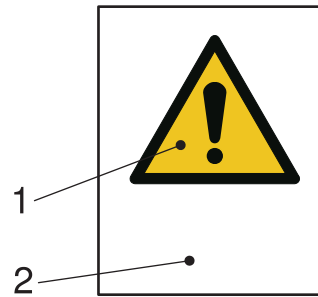

**Key**

- 1 sign W001 “General warning” from ISO 7010
- 2 supplementary text to read “Reef sails before water enters, or boat will flood and may not recover”

**b) Other boats**

**Figure 14 — Reefing safety signs**

7.7.4.5 In [Figure 14](#) a) the wind speed given shall be obtained using [7.7.4.3](#).

**7.8 Inverted buoyancy**

7.8.1 Because some sailing boats may be capsized if incorrectly handled, it shall be shown that, when the boat is inverted and/or fully flooded, either

- a) the volume of buoyancy, expressed in cubic metres, in the hull, fittings and equipment is greater than the number represented by  $(m_{LDC}/850)$ , using the method of [Annex E](#), thus ensuring that it is sufficient to support the mass of the loaded boat by a margin. Habitable parts of the boat may not be included. Dedicated air tanks and watertight compartments not containing habitable parts of the boat may be included. Apart from these, allowance for trapped bubbles of air shall not be included; alternatively,
- b) the boat when loaded to  $m_{LDC}$  does not sink, as demonstrated by a physical test.

7.8.2 Where non-habitable compartments accessible via watertight hatches or doors are used to demonstrate positive flotation after capsize, the compartment shall be constructed to watertightness degree 1 (see ISO 11812), with hatches and doors satisfying the watertightness requirements for degree 2 of ISO 12216.

7.8.3 Closures to access openings into watertight compartments shall be clearly marked on both sides in upper case letters not less than 4,8 mm high:

“KEEP SHUT WHEN UNDER WAY”

NOTE “Under way” has the meaning “not at anchor, or made fast to the shore, or aground”

7.8.4 Where flotation elements are used, the requirements of [Annex D](#) shall be satisfied.

## 8 Safety signs

Safety signs shall be placed where they are clearly visible, and shall be made of rigid plate or flexible labels affixed to the craft in such a way that they can only be removed by the use of tools. The size of the symbols and text shall comply with [Table 8](#). Text shall be in black on a white background, using a plain sans serif typeface such as Arial Narrow. The language used shall be acceptable or as required in the country of intended use. The design of the signs shall comply with ISO 3864-1.

**Table 8 — Size of safety signs and supplementary text**

Parameter	Expected viewing distance, $D$ (m)				
	$D \leq 0,6$	$0,6 < D \leq 1,2$	$1,2 < D \leq 1,8$	$1,8 < D \leq 2,4$	$D > 2,4$
Minimum height of warning sign (mm)	20,0	20,0	30,0	40,0	50,0
Minimum height of capital letters (mm)	2,4	4,8	7,2	9,6	12,0
Minimum height of lower case letters (mm) <sup>a</sup>	1,7	3,4	5,1	6,9	8,6
<sup>a</sup> For example, height of letter "e"					

## 9 Application

### 9.1 Deciding the design category

The design category finally given in respect of stability and buoyancy is that for which the boat complies with all the appropriate tests, as required by [Clause 5](#).

### 9.2 Meaning of the design categories

**9.2.1** A boat given design category C is considered to be designed to operate in typical steady winds of Beaufort force 6 or less and the associated significant waves heights of up to 2 m.

NOTE Typically such conditions might be encountered on exposed inland waters, in estuaries, and in coastal waters in moderate weather conditions. Depending on atmospheric conditions, winds can gust to about 18 m/s.

**9.2.2** A boat given design category D is considered to be designed to operate in typical steady winds of Beaufort force 4 or less and the associated significant waves heights of up to 0,3 m and occasional waves of 0,5 m height.

NOTE Typically such conditions might be encountered on sheltered inland waters, and in coastal waters in fine weather. Depending on atmospheric conditions, winds can gust to about 12 m/s.

**9.2.3** The significant wave height is the mean height of the highest one-third of the waves, which approximately corresponds to the wave height estimated by an experienced observer. Some waves will be double this height.

NOTE The definitions of these design categories align with those used in the Recreational Craft Directive of the European Union, EU Directive 2013/53/EU.

## Annex A (normative)

### Full method for required downflooding height

The required downflooding height may be calculated according to the method set out below instead of using [Figure 2](#). In all cases, the limits given in [Table A.1](#) apply to the required height calculated by the formula below.

**Table A.1 — Limits on required downflooding height**

Dimensions in metres

Parameter	Design category		
	C	D	D
Options	1-4, 6, 10, 11	1-4, 6, 10, 11	5
$h_{D(R)}$ shall not be less than	0,3	0,2	0,4
$h_{D(R)}$ shall not be more than	0,75	0,4	—

The downflooding height required ( $h_{D(R)}$ ) is calculated separately for each downflooding opening as follows:

$$h_{D(R)} = H_1 \times F_1 \times F_2 \times F_3 \times F_4 \times F_5 \tag{A.1}$$

where

$$H_1 = L_H/15$$

$F_1$  is the opening position factor (varies between 0,5 and 1,0):

= 1,0 where the downflooding opening is in the periphery of the boat, e.g. for undecked, open boats, or openings in topsides:

$F_1 = (1 - x_D/L_H)$  or  $(1 - y_D/B_H)$ , whichever is greater, see [Figure A.1](#).

where

$x_D$  is the longitudinal distance of a downflooding opening from the nearest extremity of  $L_H$ ;

$y_D$  is the least transverse distance of a downflooding opening from the periphery of the boat;

$F_2$  is the opening size factor (varies between 0,6 and 1,0):

$$= 1,0, \text{ if } a \geq (30L_H)^2 \tag{A.2}$$

where

$a$  is the total combined area of openings up to the top of any downflooding opening, expressed in square millimetres;

$$F_2 = 1 + \frac{x'_D}{L_H} \left( \frac{\sqrt{a}}{75L_H} - 0,4 \right) \text{ if } a < (30L_H)^2; \quad (\text{A.3})$$

where

$x'_D$  is the longitudinal distance of the opening from the forward limit of  $L_H$ .

$F_3$  is the recess size factor, greater than 0,7 but never to be taken as greater than 1,2:

= 1,0 where the opening is not a recess, otherwise:

= 0,7 if the recess is quick-draining;

= 0,7 +  $k^{0,5}$  if the recess is not quick-draining;

where

$$k = V_R / (L_H B_H F_M)$$

where

$V_R$  is the volume of a non-quick-draining recess, expressed in cubic metres.

$F_4$  is the displacement factor (typically this is between about 0,7 and 1,1):

$$= \left( \frac{10 V_D}{L_H B^2} \right)^{1/3} \quad (\text{A.4})$$

where

$V_D$  is the volume of displacement in the maximum load condition,  $V_D = m_{LDC} / 1\,025$ ;

$B$  is  $B_H$  for monohull, and  $B_{WL}$  for catamarans and trimarans.

$F_5$  is the flotation factor:

= 0,8 for boats using options 1 and 3, see [Table 3](#);

= 0,9 for boats using option 6;

= 1,0 for boats using options 2, 5, 10 and 11;

= 1,25 for boats using option 4.



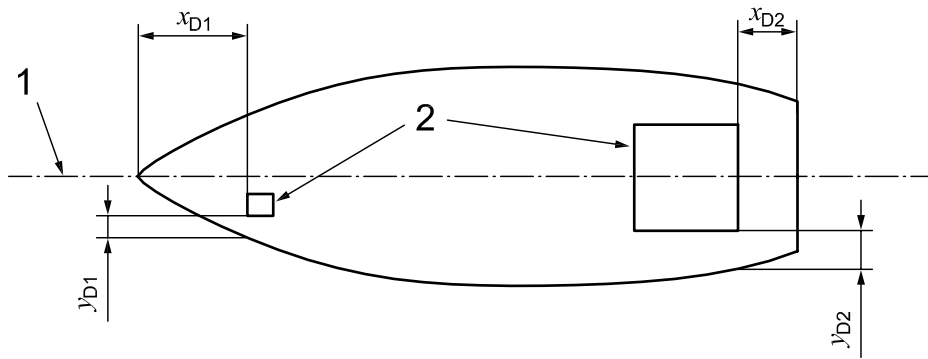

**Key**

- 1 centreline
- 2 downflooding opening

**Figure A.1 — Dimensions  $x_D$  and  $y_D$**

## Annex B (normative)

### Methods for calculating downflooding angle

#### B.1 Choice of method

Either of the methods [B.2](#) or [B.3](#) may be used.

#### B.2 Theoretical calculation

The downflooding angle is most accurately determined by computer calculation, using the shape of the hull from the lines plan. Most software packages for calculating stability have provision for finding the angle of heel at which points with specified coordinates become submerged. Thus, if righting moments are determined using computer software, downflooding angles can be obtained at the same time.

#### B.3 Approximate method for downflooding angles up to 60°

The following approximate method may be used for estimating the downflooding angle of monohulls, but is only suitable for angles less than about 60°:

$$\phi_D = \tan^{-1}(z_D/y'_D) \quad (\text{B.1})$$

$$\phi_D \text{ is the angle whose tangent is } (z_D / y'_D) \quad (\text{B.2})$$

where

$z_D$  is the height, expressed in metres, to downflooding point above the waterline;

$y'_D$  is the transverse distance, expressed in metres, of the downflooding point from the centreline of the boat.

See [Table B.1](#) and [Figure B.1](#).

**Table B.1 — Approximate method for downflooding angle**

$z_D/y'_D$	$\phi_D$ degrees
0,10	5,7
0,15	8,5
0,20	11,3
0,25	14,0
0,30	16,7
0,35	19,3
0,40	21,8
0,45	24,2
0,50	26,6
0,55	28,8

Table B.1 (continued)

$z_D/y'_D$	$\phi_D$ degrees
0,60	31,0
0,65	33,0
0,70	35,0
0,75	36,9
0,80	38,7
0,85	40,4
0,90	42,0
0,95	43,5
1,00	45,0
1,05	46,4
1,10	47,7
1,15	49,0
1,20	50,2
1,30	52,4
1,40	54,5
1,50	56,3
1,60	58,0
1,70	59,5

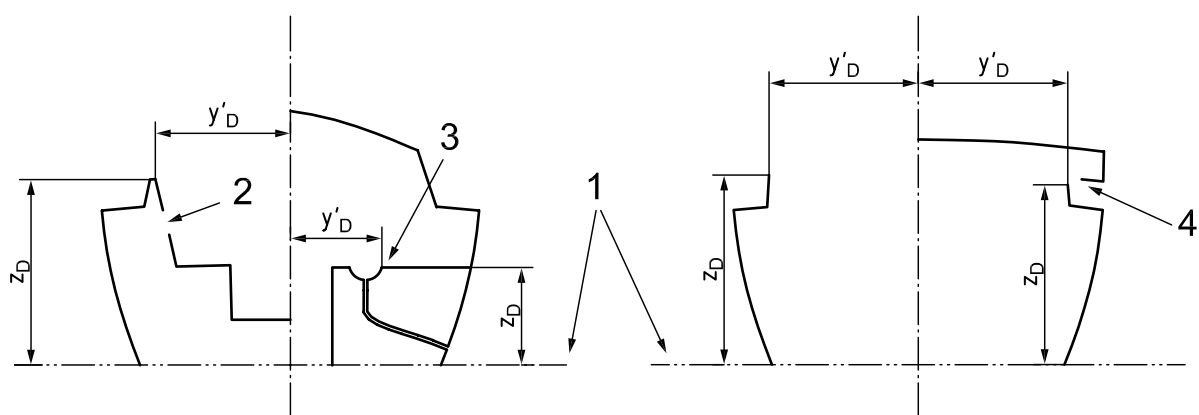

Key

- 1 waterline
- 2 downflooding opening protected by coaming
- 3 example of internal downflooding opening
- 4 example of engine air inlet

Figure B.1 — Approximate method for downflooding angle

## Annex C (normative)

### Method for flotation tests

#### C.1 General

The methods described in [C.2](#), [C.3](#) and [C.4](#) shall be used, either by actual test or equivalent calculation.

#### C.2 Test condition

During the tests, the boat shall be in calm water in the light craft condition and then equipped as follows:

- a) A mass equal to 25 % of the dry mass of stores and equipment included in the maximum total load shall be added on the interior deck, on the centreline at  $L_H/2$ .
- b) Vulnerable items, such as engines, may be replaced with an appropriate mass at the appropriate location.
- c) For outboard engines, the builder's maximum recommended power shall be used. [Tables C.1](#) and [C.2](#), columns 2 and 4 give the appropriate replacement mass to be used with respect to engine power for petrol engines. A heavier mass may be used if it is recorded in the owner's manual. A mass of 86 % of the engine dry mass shall be used for diesel, jet-propulsor or electric outboards, if these are supplied as the standard outfit. Boats equipped for use both with and without an outboard engine shall be tested in both conditions.
- d) For inboard engines, the replacement mass shall be lead, steel or iron of a mass equal to 75 % of the installed dry mass of the engine and stern-drive.
- e) Replacement masses shall, as far as practicable, have the same position of centre of gravity as the actual engine.
- f) Portable fuel tanks shall be removed. Fixed tanks shall either be removed, or shall be full with either fuel or water.
- g) All cockpit and similar drains normally open during operation of the boat shall be left open. The plugs of drains for emptying the boat of residual water when ashore shall be in place.
- h) Care shall be taken throughout the testing to eliminate entrapped air other than in air tanks or air containers.
- i) Void compartments integral with the boat structure and not complying with the requirements for air tanks in [Annex D](#) shall be opened so that they become swamped with water.
- j) Boats intended to be fitted with engines of more than 3 kW and which are fitted with integral air tanks which have laminated, glued, welded or bolted seams in their construction, and which air tanks do not comply with the enhanced pressure test of [Annex D](#), shall have a number of air tanks opened to atmosphere during testing, according to [Table C.3](#).

**Table C.1 — Mass of single-engine installations**

Engine power kW	Engine + controls		Battery	
	kg		kg	
	Column 1 Dry	Column 2 Swamp	Column 3 Dry	Column 4 Swamp
0 to 1,5	13,7	11,7	—	—
1,6 to 2,9	18,2	15,5	—	—
3,0 to 5,2	40,9	34,8	—	—
5,3 to 11,2	60,0	51,0	9,1	5,0
11,30 to 18,7	104,5	88,9	20,5	11,4
18,8 to 33,6	124,1	106,2	20,5	11,4
33,7 to 44,8	161,7	138,2	20,5	11,4
44,9 to 56,0	188,5	161,0	20,5	11,4
56,1 to 74,6	207,6	177,2	20,5	11,4
74,7 to 108,2	258,6	220,5	20,5	11,4
108,3 to 164,1	260,7	222,3	20,5	11,4
164,2 and over	312,5	266,3	20,5	11,4

NOTE Power in kilowatts = (Imperial horsepower) × 0,745 7  
 Imperial horsepower = (Power in kilowatts) × 1,341  
 Power in kilowatts = (Metric horsepower) × 0,735 5  
 Metric horsepower = (Power in kilowatts) × 1,360

**Table C.2 — Mass of twin-engine installations**

Total engine power kW	Engine + controls		Battery	
	kg		kg	
	Column 1 Dry	Column 2 Swamp	Column 3 Dry	Column 4 Swamp
37,6 to 67,2	247,9	212,2	40,9	22,7
67,3 to 89,6	323,3	276,2	40,9	22,7
89,7 to 112,0	376,8	321,8	40,9	22,7
112,1 to 149,2	415,0	354,2	40,9	22,7
149,3 to 216,4	517,1	440,9	40,9	22,7
216,5 to 328,2	521,2	444,5	40,9	22,7
328,3 and over	624,9	532,5	40,9	22,7

**Table C.3 — Number of air tanks to be opened**

Total number of air tanks	Number to be opened
≤ 4	Single largest
> 4 but ≤ 8	Two largest
> 8	Three largest

### C.3 Swamped stability test

**C.3.1** A metallic test weight with a dry mass of  $6dCL$  kg but not less than  $15d$  kg shall be suspended over the side of the boat at each of four positions in turn. These positions shall be at  $L_H/3$  from the ends of the boat (as shown in [Figure C.1](#)) or at the ends of the cockpit, if this is nearer amidships. There shall be no other test weights in the boat during this test, apart from those required by [C.2](#).

**C.3.2**  $d$  is a coefficient to account for the buoyancy of the test weight, as given in [Table C.4](#). Where test weights are not all of the same material, the calculation should be similar to:

$$\frac{m_{LD}}{1,099} + \frac{m_{CI}}{1,163} + \frac{m_{AL}}{1,612} = 6CL \tag{C.1}$$

where

$m_{LD}$  is the mass of lead weights, expressed in kilograms;

$m_{CI}$  is the mass of cast-iron weights, expressed in kilograms;

$m_{AL}$  is the mass of aluminium weights, expressed in kilograms.

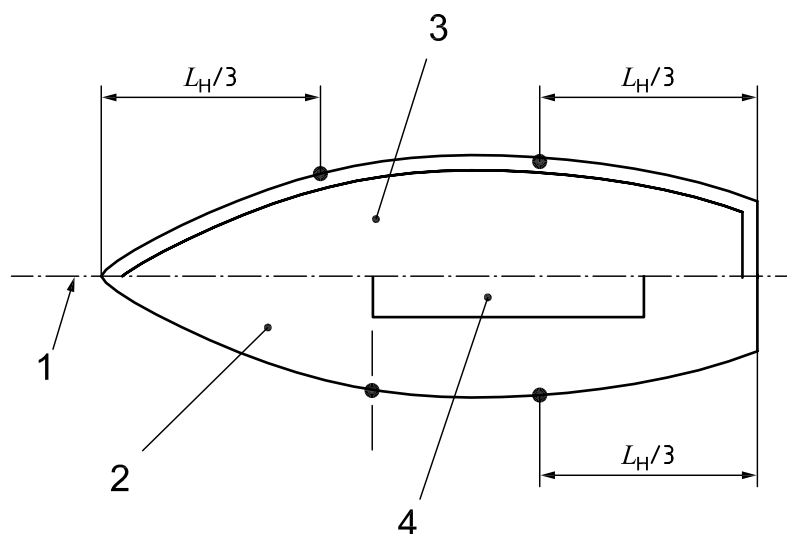

**Key**

- 1 centreline
- 2 deck
- 3 open boat
- 4 cockpit

**Figure C.1 — Positioning test weights**

**Table C.4 — Material coefficient**

Property	Material				
	Lead	65/35 brass	Steel	Cast iron	Aluminium
Value of $d$	1,099	1,138	1,151	1,163	1,612

**C.3.3** As an alternative to suspending a test weight over the side, an equivalent heeling moment (calculated when the boat is upright) may be applied using weights or persons positioned inside the boat at seat level. Persons may only be used if they are not immersed when the boat is heeled.

**C.3.4** With the test weight in each position in turn, swamp the boat by applying a downwards force at a position on the gunwale at approximately mid- $L_H$  until the deepest point of the gunwale or coaming is 0,2 m below the water surface. Hold the boat in this position until the water level has equalized, or for 5 min, whichever is less, and then release the boat.

NOTE It is often helpful to partially fill the boat with water before swamping in this manner.

**C.3.5** For each position of the test weights, after a further 5 min have elapsed, the boat shall not heel more than 45°.

## C.4 Swamped buoyancy tests

### C.4.1 General

Boats of  $L_H < 4,8$  m shall satisfy both the tests described in [C.4.2](#) and [C.4.3](#). Boats of  $L_H \geq 4,8$  m shall satisfy the test described in [C.4.3](#).

### C.4.2 One-person test

**C.4.2.1** Load metallic test weights with a dry mass of  $75d$  on the inner bottom of the boat. Alternatively, provided they are not immersed above the knee, a person may be used instead of test weights, provided that they have a total dry mass of not less than 82,5 kg. This mass may be located at any longitudinal position needed to satisfy [C.4.2.3](#).

**C.4.2.2** Swamp the boat by applying a downwards force at a position on the gunwale at approximately mid- $L_H$  until the deepest point of the gunwale or coaming is 0,2 m below the water surface. Hold the boat in this position until the water level has equalized, or for 5 min, whichever is less, and then release the boat.

NOTE It is often helpful to partially fill the boat with water before swamping in this manner.

**C.4.2.3** After a further 5 min have elapsed, it shall be demonstrated that the swamped boat floats such that the residual freeboard and the corresponding position of the one person allow the latter to pump or bail the boat dry.

### C.4.3 Load test

**C.4.3.1** Load metallic test weights on the inner bottom of the boat, evenly about the centre of the area available to the crew, according to the crew limit (CL) as given in [Table C.5](#). This area shall have a minimum headroom clearance of 0,6 m above the swamped waterline. Alternatively, provided they are not immersed above the knee, people may be used instead of test weights, provided that they have a total dry mass of not less than the required mass of test weights if  $d$  is taken as 1,1.

**Table C.5 — Mass of load test weights**

Mass in kilograms

Property	Design category C	Design category D
Dry mass more than	$d(60 + 15CL)$	$d(50 + 10CL)$

**C.4.3.2** Swamp the boat by applying a downwards force at a position on the gunwale at approximately mid- $L_H$  until the deepest point of the gunwale or coaming is 0,2 m below the water surface. Hold the boat in this position until the water level has equalized, or for 5 min, whichever is less, and then release the boat.



NOTE It is often helpful to partially fill the boat with water before swamping in this manner.

**C.4.3.3** Boats required to satisfy the level flotation standard shall, after a further 5 min have elapsed, float approximately level with more than two-thirds of the length of the top of the gunwale or coamings (including those across bow or stern) above water.

**C.4.3.4** Boats required to satisfy the basic flotation standard shall, after a further 5 min have elapsed, continue to float, but may float at any attitude.

NOTE The values of the formulae given in [C.3.1](#) and [C.4.3.1](#) are given in [Table C.6](#).

**Table C.6 — Mass of test weights**

Mass in kilograms

Formula	Crew limit (CL)									
	1	2	3	4	5	6	7	8	9	10
$6dCL, \text{ min. } 15d =$	$15d$	$15d$	$18d$	$24d$	$30d$	$36d$	$42d$	$48d$	$54d$	$60d$
$d(60 + 15CL) =$	$75d$	$90d$	$105d$	$120d$	$135d$	$150d$	$165d$	$180d$	$195d$	$210d$
$d(50 + 10CL) =$	$60d$	$70d$	$80d$	$90d$	$100d$	$110d$	$120d$	$130d$	$140d$	$150d$

## Annex D (normative)

### Flotation material and elements

#### D.1 Requirements

Flotation elements as defined in [Clause 3](#) shall comply with the requirements in [Table D.1](#). Other types of flotation elements shall be evaluated following the same principles.

Those materials or parts of the boat which are not primarily intended to provide flotation but which nevertheless contribute to the flotation characteristics shall not be subject to the requirements in this annex.

**Table D.1 — Requirements for flotation elements**

Property	Air tank	Air container	Inflated bag and rib collar	Low density material
Airtightness	RT	RT	R	—
Mechanical robustness or protection	R	R	R	R
Draining facility	R	R	—	—
Resistant to or protected from sunlight	—	R	R	R
Fitted with an inflation point	—	—	R	—
Temperature resistant -40 °C to +60 °C	—	—	—	R
Water absorption max. 8 % by volume	—	—	—	R
Securely fastened to withstand buoyancy force	—	R	R	R
Encapsulated or resistant to liquids	—	—	R	R
Label: "Do not puncture air tank/container/bag"	R	R	R	—
NOTE 1 R denotes that this property is required but is not subject to a specific test by the builder.				
NOTE 2 RT denotes that this property is required, and is required to be tested by the builder.				

#### D.2 Tests

The water absorption of low-density material shall not exceed 8 % by volume after being submerged for 8 d according to ISO 2896. Material complying with IMO Resolution MSC.81(70)<sup>[3]</sup> shall be deemed to satisfy this requirement.

Where air tanks or air containers are used, they shall be subject to a pressure test, carried out at an initial over-pressure, with a permitted pressure drop within 30 s, as given in [Table D.2](#).

Boats intended to be fitted with engines of more than 3 kW and which are fitted with integral air tanks which have laminated, glued, welded or bolted seams in their construction, and which air tanks do not comply with the enhanced pressure test, shall have a number of air chambers opened to atmosphere during testing, according to [Table C.3](#).

**Table D.2 — Test pressures**

<b>Condition</b>	<b>Enhanced pressure test</b>	<b>Basic pressure test</b>
Chambers required to be opened during flotation tests	None	As detailed in <a href="#">Table C.3</a>
Initial over-pressure	2,5 kPa (250 mm water)	1,25 kPa (125 mm water)
Maximum pressure drop in 30 s	1,0 kPa (100 mm water)	0,75 kPa (75 mm water)

Breather holes in air tanks designed for the relief of air pressure due to variations in ambient temperature may be temporarily sealed during the above test, provided that their position does not alter the effectiveness of the tank during the flotation tests of [Annex C](#) or the tests required by [7.4](#), [7.5](#) or [7.6](#).

## Annex E (normative)

### Calculation method for basic flotation requirement

#### E.1 Introduction

[E.2](#) sets out the calculation method for complying with the basic flotation requirement, by showing that when a flooded or inverted boat is totally immersed, the buoyancy available from the hull structure, fittings, and flotation elements exceeds that required to support the mass of the boat prepared in accordance with [C.2](#) and loaded in accordance with [C.4.3](#) by a defined margin.

#### E.2 Method

**E.2.1** Calculate the volume of the various elements of the boat by direct calculation and/or from a knowledge of the mass and density of the different materials, using the expression:

$$V = m/\rho \quad (\text{E.1})$$

where

- $V$  is the volume of an element, expressed in cubic metres;
- $m$  is the mass of that element, expressed in kilograms;
- $\rho$  is the density of that element, expressed in kilograms per cubic metre.

**E.2.2** Calculate the total buoyant volume of the boat,  $V_B$ , by adding together the volumes of

- the hull structure (see [Table E.1](#)),
- the gross volume of fixed tanks for fuel, water, or other stored fluids, and of batteries, and
- the gross volume of air tanks or containers meeting the requirements of [Annex D](#).

The buoyant volume of engines and other fittings and equipment may also be included (see [Table E.1](#)). Omitting them will enhance the safety margin.

No allowance shall be included for trapped bubbles of air, or for crew, masts, or sails and rigging other than that stowed below decks.

**E.2.3** Show that

$$V_B > \frac{m_{\text{TEST}}}{930} \quad \text{for options 6, 8 or 9} \quad (\text{E.2})$$

$$V_B > \frac{m_{\text{TEST}}}{850} \quad \text{for option 11} \quad (\text{E.3})$$

where

- $V_B$  is the total buoyant volume of the boat, expressed in cubic metres, calculated in [E.2.2](#);

$m_{\text{TEST}}$  is the mass of the boat prepared and loaded in accordance with C.2 and C.4.3, expressed in kilograms.

### E.3 Material densities

The densities in Table E.1 shall be used for calculating the volume of components.

**Table E.1 — Material densities**

Densities in kilograms per cubic metre

Material	Density
Lead	11 400
Bronze	8 900
Brass (65/35)	8 450
Steel	7 800
Cast iron	7 300
Aluminium alloys	2 700
GRP laminate	1 500
Flotation foam materials	40
Structural foam materials	80
Balsa core material	150
Oak	770
Teak	640
Mahogany	550
Miscellaneous equipment	2 000
Food and other stores	2 000
Stowed sails and ropes	1 200
Window glass	2 500
Window plastic	1 200
Diesel engines	5 000
Petrol engines	4 000
Outboard engines	3 000
Sail-drive struts	3 000
Stern-drive struts	3 000
Plywood	600
Western red cedar	370
Spruce	430

## Annex F (normative)

### Information for owner's manual

#### F.1 General information

The following stability information, as appropriate to the design, shall be included in the owner's manual defined in ISO 10240.

A maximum load has been used for assessing stability and buoyancy comprising

- manufacturer's maximum recommended load per ISO 14946 ..... kg
- fuel, fresh water, other fluids to maximum capacity of fixed tanks ..... kg
- \_\_\_\_\_
- Maximum load ..... kg

This assessment has been made assuming that

- the boat in the empty craft condition has a mass of ..... kg
- the boat in the light craft condition has a mass of ..... kg
- the maximum recommended outboard engine mass is ..... kg
- all standard equipment is aboard.

#### F.2 Specific information

If appropriate, the following information should be included in the owner's manual.

- a) **IMPORTANT — This boat is only intended to be sailed with the centreboard(s) or drop keel(s) locked in the lowered position.** (*where the stability has only been assessed in this condition, see [7.6.2](#) and [7.7.2.1](#)*).
- b) **IMPORTANT — Failure to observe these limitations may result in the boat capsizing.**

Where certain parts of the boat have had crew access restricted by the offset-load test of [6.5](#), the following text shall be included, as appropriate:

- c) For stability reasons, the following parts of the boat should only be accessed by people in exceptional circumstances: (*insert list of relevant locations*). Such locations are indicated by the following safety sign:

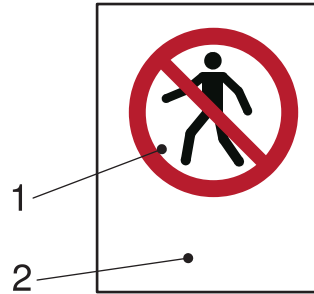
**Key**

- 1 sign P004 “No thoroughfare” from ISO 7010
- 2 supplementary text to read “No access”

**Figure F.1 — No access sign**

- d) For stability reasons, the following parts of the boat should only be accessed by more than the indicated number of persons in exceptional circumstances: *(insert list of relevant locations, e.g. deck, coachroof, flybridge, and limit on each location)*. Such locations are indicated by the following safety sign and/or a sign at the each control position:

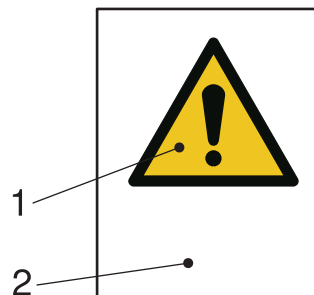
**Key**

- 1 sign W001 “General warning” from ISO 7010
- 2 supplementary text to read “Max  $N$  persons on (location)” where  $N$  is the relevant number and (location) is expressed for example as “flybridge” or “coachroof”

**Figure F.2 — Limited access sign**

- e) The following openings are marked “KEEP SHUT WHEN UNDER WAY”, and care should be taken to observe this warning: *(insert list of relevant opening locations)*. “Under way” has the meaning “not at anchor, or made fast to the shore, or aground”. *(Text to be inserted when required according to 6.3.1.5)*.
- f) This boat has been assessed as capable of supporting the crew even when swamped *(when meeting the requirements of 6.7, 6.8, 6.9, 7.5 or 7.6)*.
- g) This boat is susceptible to capsize and is intended to be recovered by the crew after a capsize. The minimum crew mass needed is ... kg, and the following technique is recommended: *(insert as appropriate)*. The likelihood of capsize of this boat when being used in normal circumstances is ... *(boats assessed using 6.9 or 7.5)*. If the boat is fitted with a cabin, users should be aware that persons inside may become trapped after a capsize.



The following safety signs warn of these hazards.

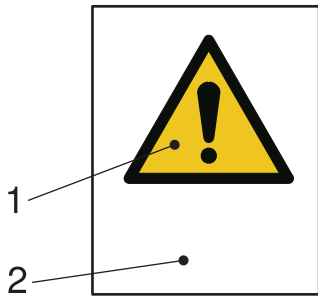

**Key**

- 1 sign W001 “General warning” from ISO 7010
- 2 supplementary text to read “Risk of capsize!”

**a) Where there is no cabin**

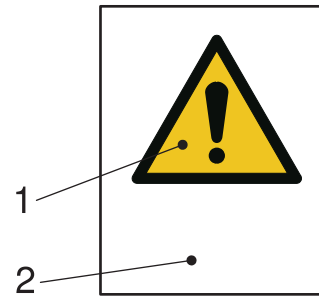

**Key**

- 1 sign W001 “General warning” from ISO 7010
- 2 supplementary text to read “Risk of capsize! Persons in cabin may be trapped!”

**b) Where boat is fitted with a cabin**

**Figure F.3 — Risk of capsize sign**

- h) This boat may swamp or capsize if excessive sail is carried. It is designed not to sink if this occurs. The working sail plan should be reduced if the apparent wind exceeds ... knots/metres per second. Particular care should be taken in gusty wind conditions. The following safety sign warns of this hazard. (*Boats assessed using 7.7*)

The following safety sign warns of this hazard.

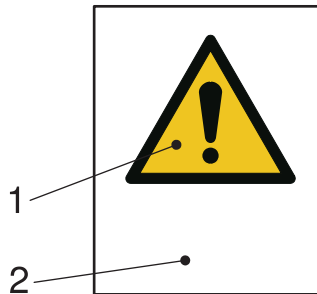

**Key**

- 1 sign W001 “General warning” from ISO 7010
- 2 supplementary text to read “Reef sails at  $N$  knots (or m/s) apparent wind speed”, where  $N$  is the relevant wind speed

**a) Fully enclosed boats**

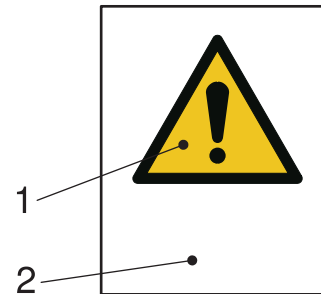

**Key**

- 1 sign W001 “General warning” from ISO 7010
- 2 supplementary text to read “Reef sails before water enters, or boat will flood and may not recover”

**b) Other boats**

**Figure F.4 — Reefing warning signs**

- i) This boat has limited stability and is therefore at greater risk of capsize or swamping. Users should take special care to keep the boat upright by adjusting their position in the boat. The following safety sign warns of this hazard. (*Boats assessed using [6.5.3.4](#)*)

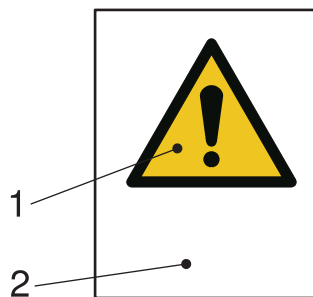

**Key**

- 1 sign W001 “General warning” from ISO 7010
- 2 supplementary text to read “Risk of capsizing or swamping”

**Figure F.5 — Risk of capsizing or swamping sign**

- j) This boat will capsize or swamp if a load of 85 kg is placed on the gunwale. Users should not sit or stand on the gunwale. The following safety sign warns of this hazard. (*Boats failing the test in [6.5.4](#)*)

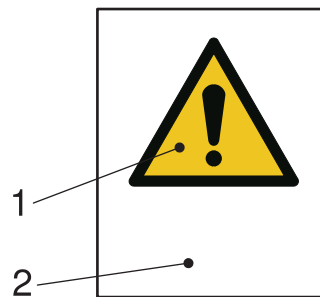

**Key**

- 1 sign W001 “General warning” from ISO 7010
- 2 supplementary text to read “Do not sit on gunwale”

**Figure F.6 — Do not sit on gunwale sign**

## Annex G (informative)

### Summary of requirements

The design category given in respect of stability and buoyancy is that for which the boat satisfies all the requirements according to 6.1, as summarized in Table G.1, or 7.1, as summarized in Table G.2.

**Table G.1 — Summary of requirements for non-sailing boats**

Configu- ration or requirement	Option number		1		2		3	4		5	6	
	Design category		C	D	C	D	D	C	D	D	C	D
	Lengths applicable		$L_H \leq 6,0$ m					$L_H \geq 4,8$ m and $L_H \leq 6,0$ m				
Degree of decking or covering	Partially protected		—	—	—	—	—	yes	yes	—	—	—
	Not fully enclosed		yes	yes	—	—	yes	—	—	yes	yes	yes
	Fully enclosed		—	—	yes	yes	—	—	—	—	—	—
Habitable multihulls (6.2)			Refer to Clause 6.2									
Required downflood- ing height (6.3 using Figure 2)	Shall not be less than		—	0,20	0,30	0,20	0,20	0,40	0,343	—	0,32	0,282
	Shall not be less than		0,30	$L_H/24$	$L_H/17$	$L_H/20$	$L_H/24$	$L_H/12$	$L_H/14$	0,40	$L_H/15$	$L_H/17$
	Need not be more than		—	0,25	0,353	0,30	0,25	0,50	0,40	—	0,40	0,353
Downflooding height (6.3 by Annex A)	Shall not be less than		0,30	0,20	0,30	0,20	0,20	0,30	0,20	0,40	0,30	0,20
	Need not be more than		0,75	0,40	0,75	0,40	0,40	0,75	0,40	—	0,75	0,40
Recess size (6.4)	max % loss in $GM_T$ <i>NB: only if fully enclosed</i>		—	—	1 200 $F_R/L_H$	—	—	—	—	—	—	—
Offset-load test (6.5)	Mass (kg) used per person	without safety sign Figure 8	85	85	85	85	—	85	85	85	85	85
		with safety sign Figure 8	—	$14,17 \times$ $L_H$	—	$14,17 \times$ $L_H$	—	—	—	—	—	—
	Freeboard left (m) >		0,10	0,01	0,10	0,01	—	0,15	0,01	0,17	0,10	0,01
	Heel angle limit (Table 6)		yes	—	yes	yes	—	yes	—	—	yes	—
	Gunwale load test		required if $m_{LC} < 800$ kg									
Heel due to wind (6.6)  only if $A_{LV} > 0,5L_H B_H$	when $v_W$ (m/s) =		17	13	17	13	13	17	13	13	17	13
	wind heel angle $\phi_W <$		0,7 $\phi_{0(R)}$ and 0,7 $\phi_D$	0,7 $\phi_{0(R)}$ and 0,7 $\phi_D$	0,7 $\phi_{0(R)}$ and 0,7 $\phi_D$	0,7 $\phi_{0(R)}$ and 0,7 $\phi_D$	0,7 $\phi_{0(R)}$ and 0,7 $\phi_D$	0,7 $\phi_{0(R)}$ and 0,7 $\phi_D$	0,7 $\phi_{0(R)}$ and 0,7 $\phi_D$	0,7 $\phi_{0(R)}$ and 0,7 $\phi_D$	0,7 $\phi_{0(R)}$ and 0,7 $\phi_D$	0,7 $\phi_{0(R)}$ and 0,7 $\phi_D$
Flotation test required	Level (6.7)		yes	yes	—	—	—	—	—	—	—	—
	Basic (6.8)		—	—	—	—	—	—	—	—	yes	yes
	None		—	—	yes	yes	yes	yes	yes	yes	—	—
Capsize- recovery test (6.9)	Conduct test		—	—	—	—	yes	—	—	—	—	—
	Safety sign		—	—	—	—	yes	—	—	—	—	—
Detection and removal of water (6.10)			yes	yes	yes	yes	yes	yes	yes	yes	yes	yes

**Table G.2 — Summary of requirements for sailing boats**

Configuration or requirement	Option number	7	8	9		10		11	
	Design category	C and D	C and D	C	D	C	D	C	D
Decking or covering	Not fully enclosed	yes	yes	yes	yes	—	—	—	—
	Fully enclosed	—	—	—	—	yes	yes	yes	yes
Required downflooding height (7.2) (using Figure 2)	Shall not be less than	—	—	—	—	—	0,20	—	0,20
	Shall not be less than	—	—	—	—	0,30	$L_H/24$	0,30	$L_H/24$
	Need not be more than	—	—	—	—	—	0,25	—	0,25
Downflooding height (7.2) (by Annex A)	Shall not be less than	—	—	—	—	0,30	0,20	0,30	0,20
	Need not be more than	—	—	—	—	0,75	0,40	0,75	0,40
Recess size (7.3)	max % loss in $GM_T$	—	—	—	—	$1\,200 F_R/L_H$	—	$1\,200 F_R/L_H$	—
Flotation test required (7.4)	C = level, D = basic	—	yes	yes	yes	—	—	—	—
	None	yes	—	—	—	yes	yes	yes	yes
Capsize recovery test (7.5)	Conduct test	yes	—	—	—	—	—	—	—
	Safety sign	yes	—	—	—	—	—	—	—
Knockdown recovery test (7.6)		—	yes	—	—	yes	yes	—	—
Wind stiffness test (7.7)	Conduct test	—	—	yes	yes	—	—	yes	yes
	Calc wind speed (m/s) $\geq$	—	—	11	6	—	—	11	6
	Safety sign	—	—	yes	yes	—	—	yes	yes
Inverted buoyancy (7.8)	$V_B \geq m_{LDC}/850$	—	—	—	—	—	—	—	yes
Detection and removal of water (6.10)		yes	yes	yes	yes	yes	yes	yes	yes
Apply Part 2 requirements		—	—	—	—	—	—	yes	—

**Annex H**  
(informative)

**Worksheets**

The following worksheets are provided to assist in the systematic assessment of a boat according to this part of ISO 12217.

**ISO 12217-3 BOATS OF HULL LENGTH LESS THAN 6 m**  
**CALCULATION WORKSHEET No. 1**

Design: .....

Design category intended:	Monohull/multihull:			
Item	Symbol	Unit	Value	Ref.
<u>Length of hull</u> as in ISO 8666	$L_H$	m		ISO 8666
<u>Length waterline in loaded arrival condition</u>	$L_{WL}$	m		Table 1
<u>Empty craft condition mass</u>	$m_{EC}$	kg		3.3.1
standard equipment		kg		3.4.10
water ballast in tanks which are notified in the owner's manual to be filled whenever the boat is afloat		kg		3.3.2
<u>Light craft condition mass</u> = $m_{EC}$ + standard equipment + ballast	$m_{LC}$	kg		3.3.2
<b>Mass of:</b>				
Desired Crew Limit	CL	—		3.4.2
Mass of:				
desired Crew Limit at 75 kg each		kg		3.3.3
provisions + personal effects		kg		3.3.3
drinking water		kg		3.3.3
fuel		kg		3.3.3
lubricating and hydraulic oils		kg		3.3.3
black water		kg		3.3.3
grey water		kg		3.3.3
any other fluids carried aboard (e.g. in bait tanks)		kg		3.3.3
stores, spare gear and cargo (if any)		kg		3.3.3
optional equipment and fittings not included in basic outfit		kg		3.3.3
inflatable liferaft(s) (if carried)		kg		3.3.3
other small boats carried aboard		kg		3.3.3
margin for future additions		kg		3.3.3
<u>Maximum load</u> = sum of above masses	$m_L$	kg		3.3.3
<u>Maximum load condition mass</u> = $m_{LC} + m_L$	$m_{LDC}$	kg		3.3.4
fuel and oils to be removed for loaded arrival condition		kg		3.3.5
drinking water to be removed for loaded arrival condition		kg		3.3.5
edible stores to be removed for loaded arrival condition		kg		3.3.5
<u>Loaded arrival condition mass</u>	$m_{LA}$	kg		3.3.5

Is boat sail or non-sail?	Symbol	Unit	Value	Ref.
reference sail area according to ISO 8666	$A_S$	m <sup>2</sup>		3.4.8
sail area/displacement ratio = $A_S / (m_{LDC})^{2/3}$		—		5.2
<b>CLASSIFIED AS</b> [non-sail if $A_S / (m_{LDC})^{2/3} < 0,07$ ]	SAIL/NON-SAIL?			5.2
<b>If NON-SAIL GO TO WORKSHEET No. 2</b>		<b>If SAIL GO TO WORKSHEET No. 3</b>		
<b>NB:</b> If boat is sailing but is also equipped for use as a non-sailing boat, <b>both</b> must be examined.				



**ISO 12217-3 CALCULATION WORKSHEET No. 2 NON-SAIL TESTS TO BE APPLIED**

Question	Answer	Ref.
Is boat fully enclosed? (see definition in ref.)	YES/NO	3.1.5
Is boat partially protected? (see definition in ref.)	YES/NO	3.1.6

Item	Symbol	Unit	Value	Ref.
Length of hull	$L_H$	m		ISO 8666
Length waterline in loaded arrival condition	$L_{WL}$	m		Table 1
Beam of hull	$B_H$	m		ISO 8666

Choose any ONE of the following options, and use all the worksheets indicated for that option.

Option No.	1 <sup>a</sup>	2	3 <sup>a</sup>	4	5	6 <sup>a</sup>
Applicable to	$L_H \leq 6,0$ m			$L_H \geq 4,8$ m and $L_H \leq 6,0$ m		
Design categories possible	C and D	C and D	D	C and D	D only	C and D
Applicable to engine powers of	Any amount	Any amount	$\leq 3$ kW	Any amount	Any amount	Any amount
Applicable to the following types of engine installation	Any	Any	Any	Any	Any	Inboard engines only
Decking or covering	All boats except 'fully enclosed' <sup>b</sup>	Fully enclosed <sup>c</sup>	All boats except 'fully enclosed' <sup>b</sup>	Partially protected <sup>d</sup>	All boats except 'fully enclosed' <sup>b</sup>	All boats except 'fully enclosed' <sup>b</sup>
Downflooding height test	4 <sup>e</sup> or 5 <sup>e</sup>	4 or 5	4 or 5	4 or 5	4 or 5	4 or 5
Recess size	—	6 <sup>f</sup>	—	—	—	—
Offset load test	7	7	—	7	7	7
Heel due to wind	8 <sup>g</sup>	8 <sup>g</sup>	8 <sup>g</sup>	8 <sup>g</sup>	8 <sup>g</sup>	8 <sup>g</sup>
Flotation standard	Level	—	—	—	—	Basic
Flotation test	9	—	—	—	—	9 or 10
Flotation elements	Annex D	—	Annex D	—	—	Annex D
Capsize recovery test	—	—	11	—	—	—
Detection & removal of water	14	14	14	14	14	14
SUMMARY	15	15	15	15	15	15

<sup>a</sup> Boats using options 1, 3 and 6 are considered to be susceptible to swamping when used in their design category.  
<sup>b</sup> That is, any boat that is not 'fully enclosed', thus including boats without any decking.  
<sup>c</sup> This term is defined in 3.1.5.  
<sup>d</sup> This term is defined in 3.1.6.  
<sup>e</sup> The downflooding height test is not required to be conducted on the following boats:  
 — those which, when tested in accordance with normative C.4.3, have been shown to support, in addition to the mass required by C.2 and Table C.5, an additional equivalent dry mass (kg) of  $(75 \cdot CL + \text{dry mass of stores and equipment included in the maximum total load})$ , or  
 — those boats that do not take on water when heeled to 90° from the upright in the light craft condition.  
<sup>f</sup> This test only applies to boats of design category C.  
<sup>g</sup> The application of Worksheet 8 is only required for boats where  $A_{LV}/(L_H B_H) > 0,5$ .

<b>Option selected</b>	
------------------------	--

**ISO 12217-3 CALCULATION WORKSHEET No. 3 SAIL BOAT TESTS TO BE APPLIED**

Question			Answer	Ref.
Is boat fully enclosed? (see definition in ref.)			YES/NO	3.1.5
Is boat a monohull?			YES/NO	
Length of hull	$L_H$	m		ISO 8666
mass in the empty craft condition	$m_{EC}$	kg		3.3.1
<b>NB: If the boat can also be used as a non-sailing boat, it must also complete the corresponding tests required according to Worksheet 2.</b>				

Choose any ONE of the following options, and use the worksheets indicated for that option.

Option No.	7 <sup>a</sup>	8 <sup>a</sup>	9 <sup>a</sup>	10 <sup>b</sup>	11 <sup>b</sup>
Design categories possible	C and D	C and D	C and D	C and D	C and D
Applicable to hull types	All	Monohull only	Monohull only	Monohull only	Multihull only
Decking or covering	All boats except 'fully enclosed' <sup>c</sup>	All boats except 'fully enclosed' <sup>c</sup>	All boats except 'fully enclosed' <sup>c</sup>	Fully enclosed	Fully enclosed
Downflooding height test	—	—	—	4 or 5	4 or 5
Recess size	—	—	—	6 <sup>d</sup>	6 <sup>d</sup>
Flotation standard design category C	—	Level	Level	—	7.8
Flotation standard design category D	—	Basic	Basic	—	7.8
Flotation test design category C	—	9	9 <sup>e</sup>	—	—
Flotation test design category D	—	9 or 8	9 or 10	—	—
Flotation elements	Annex D	Annex D	Annex D	—	—
Capsize recovery test	11	—	—	—	—
Knockdown recovery test	—	12	—	12	—
Wind stiffness test	—	—	13 <sup>f</sup>	—	13 <sup>fg</sup>
Inverted buoyancy	—	—	—	—	10
Detection & removal of water	14	14	14	14	14

- <sup>a</sup> Boats using options 7, 8 and 9 are considered to be susceptible to swamping when used in their design category, excepting those boats using option 9 and covered by the exemptions given in footnote e.
- <sup>b</sup> Alternatively, boats may be assessed using ISO 12217-2.
- <sup>c</sup> That is, any boat that is not 'fully enclosed', thus including boats without any decking.
- <sup>d</sup> Only applicable to design category C.
- <sup>e</sup> Flotation testing is not required for boats satisfying the exemptions given in 7.4.1 or 7.4.2.
- <sup>f</sup> Only applicable to boats with  $m_{EC} > 300$  kg.
- <sup>g</sup> Only applicable to design category D.

<b>Option selected</b>	
------------------------	--

**Exemption from Flotation Test in option 9**

Question	Answer	Ref.
Are conditions for exemption for design category C satisfied?	YES/NO	7.4.1
Are conditions for exemption for design category D satisfied?	YES/NO	7.4.2

## ISO 12217-3 CALCULATION WORKSHEET No. 4

## DOWNFLOODING

## Downflooding openings:

Question		Answer		Ref.
		Cat. C	Cat. D	
Have all appropriate downflooding openings been identified?	YES/NO			3.2.1
Have potential downflooding openings within the boat been identified?	YES/NO			6.3.1.4
Do all closing appliances satisfy ISO 12216?	YES/NO			6.3.1.1
Hatches or opening type windows are not fitted below minimum height above waterline?	YES/NO			6.3.1.2
Seacocks comply with requirements?	YES/NO			6.3.1.3
<b>Design categories possible:</b> C or D if all are YES				6.3.1

## Downflooding height:

Requirement	Basic requirement	Reduced value for small openings	Reduced value at outboard	Increased value at bow
applicable to	all options	all options but only if figures are used	options 1, 3, 5	options 1, 3, 5, 6
ref.	6.3.2.2 a)	6.3.2.2 e)	6.3.2.2 c)	6.3.2.2 b)
obtained from Fig. 3 or Annex A?		= basic × 0,75	= basic × 0,80	= basic × 1,15
maximum area of small openings ( $50L_H^2$ ) (mm <sup>2</sup> ) =				
Required downflood height $h_{D(R)}$ (m)	Fig. 3/Annex A	Cat. C		
	Fig. 3/Annex A	Cat. D		
Actual downflooding height $h_D$				
Design category possible				
<b>Design category possible</b> on downflooding height = lowest of above				

## Downflooding height: Outboard boats when starting:

Question	Answer	Ref.
Does person forward of engine weigh more than 75 kg?	YES/NO	6.3.3
Does mass of engine(s) fitted comply?	YES/NO	6.3.3
Is least height from waterline to flood point greater than 0,1 m?	YES/NO	6.3.3
<b>NB:</b> All boats fitted with externally mounted outboard engines must achieve YES to all the above.		

ISO 12217-3 CALCULATION WORKSHEET No. 5

DOWNFLOODING HEIGHT

Calculation using Annex A assuming use of option .....

Item	Symbol	Unit	Opening 1	Opening 2	Opening 3	Opening 4
<b>Position of openings:</b>						
Least longitudinal distance from bow/stern	$x$	m				
Least transverse distance from gunwale	$y$	m				
$F_1 = \text{greater of } (1 - x/L_H) \text{ or } (1 - y/B_H) =$	$F_1$	—				
<b>Size of openings:</b>						
Total combined area of openings to top of any down-flooding opening	$a$	mm <sup>2</sup>				
Longitudinal distance of opening from tip of bow	$x'_D$	m				
Limiting value of $a = (30L_H)^2$		mm <sup>2</sup>				
If $a \geq (30L_H)^2$ , $F_2 = 1,0$ If $a < (30L_H)^2$ , $F_2 = 1 + \frac{x'_D}{L_H} \left( \frac{\sqrt{a}}{75L_H} - 0,4 \right)$	$F_2$	—				
<b>Size of recesses:</b>						
Volume of recesses which are not quick-draining in accordance with ISO 11812	$V_R$	m <sup>3</sup>				
Freeboard amidships (see 3.3.5)	$F_M$	m				
$k = V_R / (L_H B_H F_M)$	$k$	—				
If opening is not a recess, $F_3 = 1,0$ If recess is quick-draining, $F_3 = 0,7$ If recess is not quick-draining, $F_3 = (0,7 + k^{0,5})$	$F_3$	—				
<b>Displacement:</b>						
Loaded displacement volume (see 3.4.5)	$V_D$	m <sup>3</sup>				
$B = B_H$ for monohulls, $B_{WL}$ for multihulls	$B$	m				
$F_4 = [(10 V_D) / (L_H \times B^2)]^{1/3}$	$F_4$	—				
<b>Flotation:</b>						
For boats using options 1 or 3, $F_5 = 0,8$ For boats using option 4, $F_5 = 1,25$ For boats using option 6, $F_5 = 0,9$ For all other boats, $F_5 = 1,0$	$F_5$	—				
<b>Required calc. height:</b> = $F_1 F_2 F_3 F_4 F_5 L_H / 15$	$h_{D(R)}$	m				
Required downflooding height with limits applied (see Annex A, Table A.1)	Category A	$h_{D(R)}$	m			
	Category B	$h_{D(R)}$	m			
	Category C	$h_{D(R)}$	m			
	Category D	$h_{D(R)}$	m			
<b>Measured downflooding height:</b>	$h_D$	m				
<b>Design category possible:</b>						
<b>lowest of above =</b>						

## ISO 12217-3 CALCULATION WORKSHEET No. 6

## RECESS SIZE

NB: This sheet is to be completed for the offset-load test condition.

Item	Symbol	Unit	Value		Ref.
			Recess 1	Recess 2	
Angle of vanishing stability > 90°?		YES/NO			6.4.1a)
Depth recess < 3% max breadth of the recess over >35% of periphery?		YES/NO			6.4.1b)
Bulwark height < $B_H/8$ and has $\geq 5\%$ drainage area in the lowest 25%?		YES/NO			6.4.1c)
Drainage area per side ( $m^2$ ) divided by recess volume ( $m^3$ )					6.4.1d)
Height position of drainage area (lowest 25% / lowest 50% / full depth)					6.4.1d)
Drainage area meets requirements 1) and 2) of 6.4.1 d)?		YES/NO			6.4.1d)
Recess exempt from size limit?		YES/NO			6.4.1
<b>SIMPLIFIED METHOD:</b> Use 1), 2) or 3) below.			<b>Zone 1</b>	<b>Zone 2</b>	
<b>Requirement:</b> from results below, design category possible =					6.4.2.1
Average freeboard to loaded waterline at aft end of recess	$F_A$	m			6.3.2.1
Average freeboard to loaded waterline at sides of recess	$F_S$	m			6.3.2.1
Average freeboard to loaded waterline at forward end of recess	$F_F$	m			6.3.2.1
Average freeboard to recess periphery = $(F_A + 2F_S + F_F)/4$	$F_R$	m			6.3.2.1
Category C permitted percentage loss in metacentric height ( $GM_T$ ) = $1\ 200\ F_R/L_H$					6.4.2.1
<b>1) Loss of <math>GM_T</math> used?</b>		YES/NO			6.4.2.2
second moment of area of free-surface of recess	$SMA_{RECESS}$	$m^4$			6.3.2.2
metacentric height of boat in offset load test condition	$GM_T$	m			6.3.2.2
Calculated percentage loss in metacentric height ( $GM_T$ ) = $\frac{102\ 500 \times SMA_{RECESS}}{m_{LA} \times GM_T}$					6.4.2.2
<b>2) Second moment of areas used?</b>		YES/NO			6.4.2.3
second moment of area of free-surface of recess	$SMA_{RECESS}$	$m^4$			6.4.2.3
second moment of area of waterplane of boat	$SMA_{WP}$	$m^4$			6.4.2.3
Calculated percentage loss in metacentric height ( $GM_T$ ) = $\left( \frac{245 \times SMA_{RECESS}}{SMA_{WP}} \right)$					6.4.2.3
<b>3) Recess dimensions used?</b>		YES/NO			6.4.2.4
maximum length of recess at the retention level (see 3.4.9)	$l$	m			6.4.2.4
maximum breadth of recess at the retention level (see 3.4.9)	$b$	m			6.4.2.4
Calculated percentage loss in metacentric height ( $GM_T$ ) = $270 \left( \frac{l \times b^3}{L_H \times B_H^3} \right)^{0.7}$					6.4.2.4
<b>DIRECT CALCULATION METHOD used?</b>		YES/NO			6.4.3
percentage full of water = $60 - 240\ F/L_H$					P1 6.5.3a)
wind heeling moment for intended design category	$M_W$	N·m			P1 6.5.3b)
crew heeling moment at $\phi_{GZmax}$		N·m			P1 6.5.3c)
maximum swamped righting moment up to least of $\phi_{DA}$ , $\phi_V$ or $50^\circ$		N·m			P1 6.5.3d)
required margin of righting moment over heeling moment		N·m			P1 6.5.3d)
actual margin of righting moment over heeling moment		N·m			P1 6.5.3d)
design category possible					P1 6.5.3d)
<b>Design category achieved</b>					

ISO 12217-3 CALCULATION WORKSHEET No. 7

OFFSET-LOAD TEST

Mass of people used for test

Name	Ident.	Mass (kg)
	A	
	B	
	C	
	D	
	E	
	F	

Name	Ident.	Mass (kg)
	G	
	H	
	I	
	J	
	K	
	L	

Crew area

Areas included and access limitations (if any):

Area	P/S? <sup>a</sup>	Incl?	Persons limit
main cockpit		√	
aft cockpit			
forward cockpit			
saloon			
cabins			
side decks			
fore deck			

Area	P/S? <sup>a</sup>	Incl?	Persons limit
cuddy top			
coachroof top			
wheelhouse top			
fly bridge			
swim platform			

<sup>a</sup> Note whether it is asymmetric by adding P (port) or S (starboard) to denote the larger side.

**Sketch:** Indicate possible seating locations along the length of the side to be tested using numbers, so that these may later be used to record the positions that people actually occupy. Locations shall not be closer than 0,5 m between centres, and not closer to outboard edge than 0,2 m unless on side-decks less than 0,4 m wide.

**Gunwale load test** (Only if the mass in the light craft condition is less than 800 kg)

Item	Response	Ref.
Load of 85 kg applied to gunwale?	YES/NO	6.5.4.1
Does boat capsize or swamp? (If YES, must be restricted to design category D)	YES/NO	6.5.4.2
Warning sign required?	YES/NO	6.5.4.2

**ISO 12217-3 CALCULATION WORKSHEET No. 7 (continued) OFFSET LOAD TEST**

Stability test – full procedure (Sheet to be used twice, once for stability, then for flooding)

<b>Boat being tested for:</b> <b>stability</b> <b>downflooding</b> (use for either, please circle which)						
$L_H$ (m)	<b>Min. permitted freeb'd margin</b> (see Table 4)	<b>Max. permitted heel angle</b> (°) $= 11.5 + \frac{(24 - L_H)^3}{520}$	<b>Intended crew limit (CL)</b>	<b>Intended design category</b>	<b>Mass test weights per person</b> (kg) (Cat. D only)	<b>Max. mass of test weights</b> (kg) (= 98CL)
Does boat have a list?		YES/NO	If "YES", to which side?		P/S	
Is crew area asymmetric?		YES/NO	If "YES", to which side?		P/S	
Is downflooding asymmetric?		YES/NO	If "YES", to which side?		P/S	
<b>Boat tested:</b> to P    to S    in both directions    (please circle)						

Test data:

Mass Ident.	Location		Mass (kg)	Total mass (kg)	Lever (m)	Moment (kg.m)	Heel angle (°) P/S	Min. freeb'd (m)	
	area	fore & aft						forward	aft

<b>Max mass of people allowed per above</b> kg	hence CL =	at	kg/person
--	------------	----	-----------

<b>Design category given:</b>	<b>Gunwale load test</b>	PASS/FAIL
-------------------------------	--------------------------	-----------

<b>Safety signs required:</b>	Fig. 5 YES/NO	Fig. 6 YES/NO
Fig. 7 YES/NO	Fig. 8 YES/NO	Fig. 9 YES/NO

ISO 12217-3 CALCULATION WORKSHEET No. 8

HEEL DUE TO WIND ACTION

NB: This sheet is to be completed for the offset-load test condition.

Initial check:

Item	Symbol	Unit	Value	Ref.
Windage area (NOT subject to minimum of $0,5 L_H B_H$ )	$A_{LV}$	m <sup>2</sup>		3.4.12
Length of hull	$L_H$	m		Table 1
Beam of hull	$B_H$	m		ISO 8666
Ratio $A_{LV}/(L_H B_H)$		—		6.6.1
Is ratio $A_{LV}/(L_H B_H)$ equal to or greater than 0,5?		YES/NO		6.6.1
If answer is NO, no further assessment is required.				

Calculation of wind heeling moment:

Item	Symbol	Unit	Cat. C	Cat. D	Ref.
Length waterline in offset-load test condition	$L_{WL}$	m			6.6.2
Draught at the mid-point of $L_{WL}$	$T_M$	m			6.6.2
Lever between centroids of above and below water areas	$h$	m			6.6.2
Calculation wind speed	$v_W$	m/s	17	13	
Wind heeling moment = $0,53 A_{LV} h v_W^2$ or = $0,30 A_{LV} (A_{LV}/L_{WL} + T_M) v_W^2$	$M_W$	N·m			6.6.2

Angle of heel due to wind:

Item	Symbol	Unit	Cat. C	Cat. D	Ref.
FROM RIGHTING MOMENT CURVE: angle of heel due to wind	$\phi_W$	degrees			6.6.3a)
OR ALTERNATIVELY: wind heeling moment $M_W$ divided by 9,806		kg.m			6.6.3b)
Angle of heel due to wind when moment above applied	$\phi_W$	degrees			6.6.3b)
Maximum permitted angle of heel during offset load test (from Worksheet 3)	$\phi_{O(R)}$	degrees			Table 5
Downflooding angle	$\phi_D$	degrees			3.2.3
Maximum permitted heel due to wind = lesser of $0,7 \phi_{O(R)}$ and $0,7 \phi_D$		degrees			6.6.3b)
Is angle of heel due to wind less than permitted value?		YES/NO			6.6.3
<b>Design category possible on wind heeling =</b>					



## ISO 12217-3 CALCULATION WORKSHEET No. 9

## FLOTATION TESTS

Annexes B and C assumed Crew Limit (CL) = .....

## Preparation:

Item	Unit	Response	Ref.
mass equal to 25 % of dry stores and equipment added?	YES/NO		C.2a)
inboard or outboard engine fitted?			
if inboard fitted, correct engine replacement mass fitted?	YES/NO		C.2d)
assumed outboard engine power	kW		
mass fitted to represent outboard engine, controls and battery	kg		Tables C.1 and C.2
portable fuel tanks removed and/or fixed tanks are filled?	YES/NO		C.2f)
cockpit drains open and drain plugs are fitted?	YES/NO		C.2g)
void compartments which are not air tanks are opened?	YES/NO		C.2i)
number of integral air tanks required to be opened			Table C.3
type of test weights used: lead, 65/35 brass, steel, cast iron, aluminium			C.3.2
material factor <i>d</i>			Table C.4

## Swamped stability test ( for level flotation):

Item	Unit	Response	Ref.
dry mass of test weights = (6 <i>d</i> CL) but $\geq$ (15 <i>d</i> )	kg		Table C.6
test weight hung from gunwale at each of four positions in turn?	YES/NO		C.3.1
5 mins after swamping, boat floats with less than 45° heel?	PASS/FAIL		C.3.4 + C.3.5

## Swamped buoyancy tests (for level and basic flotation):

Item	Unit	Response	Ref.
<b>Load test</b> ( for level and basic flotation)			
Design category assessed			
Dry mass of test weights used	kg		Table C.5
5 min after swamping, boat floats as required?	PASS/FAIL		C.4.3.3
<b>One person test</b> ( for level flotation boats where $L_H < 4,8$ m only)			
test weights or actual person used?			C.4.2.1
mass of test weights/person loaded on inner bottom of boat	kg		C.4.2.1
5 min after swamping, boat floats such that it can be pumped or bailed dry?	PASS/FAIL		C.4.2.3

## Flotation material and elements:

Item	Response	Ref.
All flotation elements comply with all the requirements?	PASS/FAIL	Table D.1

<b>Design category given:</b> NB: boat must obtain PASS in each relevant test above	
---	--

Annex E

**Objective:** to show that the buoyancy available from the hull structure, fittings and flotation elements equals or exceeds that required to support the boat as loaded for the swamped load test.

Item	Mass kg	Density kg/m <sup>3</sup>	Volume m <sup>3</sup> = mass/density	Ref.
<b>Hull structure:</b>				
GRP laminate		1 500		Table E.1
foam core materials				Table E.1
balsa core materials		150		Table E.1
plywood		600		Table E.1
other timber (type = )				Table E.1
permanent ballast (type = )				Table E.1
fastenings and other metalwork (type = )				Table E.1
windows ( glass/plastic)				Table E.1
<b>Engines and other fittings and equipment:</b>				
diesel engine(s)		5 000		Table E.1
petrol engine(s)		4 000		Table E.1
outboard engine(s)		3 000		Table E.1
sail-drive or stern-drive strut(s)		3 000		Table E.1
mast(s) and spar(s) (material = alloy/spruce)				Table E.1
stowed sails and ropes		1 200		Table E.1
food and other stores		2 000		Table E.1
miscellaneous equipment		2 000		Table E.1
non-integral fuel tank(s) (material = )				Table E.1
non-integral water tank(s) (material = )				Table E.1
<b>Gross volumes of fixed tanks and air containers:</b>				
fuel tank(s)				E.2.2
water tank(s)				E.2.2
other tank(s)				E.2.2
air tanks or containers meeting the requirements of normative Annex D				E.2.2
<b>Total volume of hull, fittings and equipment, <math>V_B</math> = sum of all above volumes</b>				E.2.2
mass of boat prepared and loaded according to E.2 and E.4.3	$m_{TEST}$	kg		E.2.3
calculate ratio $m_{TEST}/V_B =$				E.2.3
for options 1, 6, 8 or 9, $m_{TEST}/V_B < 930?$		YES/NO		E.2.3
for option 11, $m_{TEST}/V_B < 850?$		YES/NO		E.2.3

## ISO 12217-3 CALCULATION WORKSHEET No. 11

## CAPSIZE-RECOVERY TEST

**Objective:** to demonstrate that a boat can be returned to the upright after a capsize by the actions of the crew using their body action and/or righting devices purposely designed and permanently fitted to the boat, that it will subsequently float, and to verify that the recommended minimum crew mass is sufficient for the recovery method used.

Item	Unit	Value	Ref.
minimum number of crew required	—		6.9.5
minimum mass of crew required	kg		6.9.5
boat prepared as in 6.9.2 to 6.9.4, and 7.5.1?	YES/NO		6.9.2 to 6.9.4 and 7.5.1
does boat float for more than 5 min when fully capsized?	YES/NO		6.9.4
time required to right the boat (least time of 1 to 3 attempts)	minutes		6.9.6
is this time less than 5 min?	YES/NO		6.9.6
with one 75 kg person aboard, boat floats so it can be pumped or bailed out?	YES/NO		6.9.8
with full Crew Limit aboard, without bailing, boat floats approx. level with at least 2/3 periphery showing, for more than 5 min?	YES/NO		6.9.9
Safety signs are displayed?	YES/NO		6.9.10 or 7.5.2
<b>INFORMATION FOR OWNER'S MANUAL:</b>			
<b>likelihood of capsize occurring in normal use:</b>			
<b>Righting technique which is most successful:</b>			
<b>Minimum number of crew required:</b>		<b>Minimum mass of crew required:</b> kg	
<b>Design category recommended by the builder:</b>			

**ISO 12217-3 CALCULATION WORKSHEET No. 12 KNOCKDOWN RECOVERY TEST**

Item	Symbol	Cat. C	Cat. D	Ref.
<b>Experimental method:</b> Crew Limit	CL			3.4.2
boat prepared and persons positioned as 7.6.2 and Figure 11?	YES/NO			7.6.2
if water or other weight is used instead of persons, which is used?				7.6.2
masthead taken to		waterline	horizontal	7.6.3, 7.6.4
masthead held in position for		60 s	10 s	7.6.3, 7.6.4
boat recovers when released?	YES/NO			7.6.3, 7.6.4
boat floats so it can be pumped or bailed out?	YES/NO			7.6.3, 7.6.4
<b>If boat achieves YES to each of above, design category is OK</b>				
<b>Alternative theoretical method:</b> is GZ positive at heel angle defined above?	YES/NO			7.6.5
<b>Design category given:</b>				

## ISO 12217-3 CALCULATION WORKSHEET No. 13

## WIND STIFFNESS TEST

## Experimental method:

Item	Symbol	Unit	Unreefed	Reefed	Ref.
boat prepared and weight positioned as 7.7.2.1?		YES/NO			7.7.2.1
final tension in pull-down line	$T$	kg			7.7.2.3
perpendicular lever between pull-down and mooring lines	$h$	m			7.7.2.3 Figure 12
final angle of heel observed	$\phi_T$	degrees			7.7.2.3
beam of hull	$B_H$	m			ISO 8666
actual profile area of sails, including overlaps	$A'_S$	m <sup>2</sup>			7.7.2.4
upright lever from centre of sail area to underwater profile	$h'_{CE} + h_{LP}$	m			7.7.2.4 Figure 13
calculated wind speed = $\sqrt{\frac{13hT + 390B_H}{A'_S(h'_{CE} + h_{LP})(\cos\phi_T)^{1,3}}}$	$v_W$	m/s			7.7.2.4
<b>Design category given:</b> Category C if $v_W \geq 11$ m/s, category D if $v_W \geq 6$ m/s					7.7.4.1

**NB:** Safety signs in accordance with Figure 14 must be affixed to the boat.

## Alternative theoretical method:

Item	Symbol	Unit	Unreefed	Reefed	Ref.
righting moment curve increased by one crew to windward?		YES/NO			7.7.3.2
option (from Worksheet 3) being used					Table 7
Design category intended					3.1.1
relevant wind speed calculated	$v_W$	m/s			7.7.4.1
actual profile of projected area of sails, including overlaps	$A'_S$	m <sup>2</sup>			7.7.2.4
upright lever from centre of sail area to underwater profile	$h'_{CE} + h_{LP}$	m			7.7.2.4 Figure 13
calculate: $0,75 v_W^2 A'_S (h'_{CE} + h_{LP})$	$M_{W0}$	N-m			7.7.3.3
from righting moment curve augmented by $294B_H \cos\phi$ and wind heeling curve [= $M_{W0} (\cos\phi)^{1,3}$ ] resulting angle of heel =	$\phi$	degrees			7.7.3.4
is $\phi <$ that at which boat begins to fill with water, and $< 45^\circ$ ?		YES/NO			7.7.3.4
if YES, <b>Design category given:</b>					

**NB:** Safety signs in accordance with Figure 14 must be affixed to the boat.

ISO 12217-3 CALCULATION WORKSHEET No. 14

DETECTION  
+ REMOVAL OF WATER

Item	Response	Ref.
The internal arrangement facilitates the drainage of water to bilge suction point(s), to a location from which it may be bailed rapidly, or directly overboard? YES/NO		6.10.1
Is boat provided with means of removing water from the bilges in accordance with ISO 15083? YES/NO		6.10.2
Table 2 option used for assessment:		6.10.3
Can water in boat be detected from helm position? YES/NO		6.10.3
Method(s) used: direct visual inspection		6.10.3
transparent inspection panels		6.10.3
bilge alarms		6.10.3
indication of the operation of automatic bilge pumps		6.10.3
other means (specify):		6.10.3

## ISO 12217-3 CALCULATION WORKSHEET No. 15

## SUMMARY

Design description:						
Design category intended:			Crew Limit:		Date:	
Sheet	Item	Symbol	Unit	Value		
1	Length of hull: (as in ISO 8666)	$L_H$	m			
	Length waterline in offset load test condition	$L_{WL}$	m			
	Empty craft condition mass	$m_{EC}$	kg			
	Light craft condition mass	$m_{LC}$	kg			
	Maximum load	$m_L$	kg			
	Loaded displacement mass = $m_{LC} + m_L$	$m_{LDC}$	kg			
	Is boat sail or non-sail?	SAIL/NON-SAIL				
	NB: If boat is sailing but is also equipped for use as a non-sailing boat, <b>both</b> must be examined.					
2 and 3	Option selected:	Unit	Required	Actual	Pass/Fail	
4	Downflooding openings:	Are all requirements met?		PASS/FAIL		
4 or 5	Downflooding height:	Worksheet employed for basic height =				
	basic requirement	m	≥			
	reduced height for small openings ( <i>sheet 4 only</i> )	m	≥			
	reduced height at outboard ( <i>options 1, 3, 5 only</i> )	m	≥			
	increased height at bow ( <i>options 1, 3, 5, 6 only</i> )	m	≥			
4	Outboard boats when starting:	Are all requirements met?		YES/NO		
6	Recess size: ( <i>category C only for options 2, 10 and 11</i> )					
	max reduction in GM <sub>T</sub>	%	≤			
7	Gunwale load test: ( <i>only if <math>m_{EC}</math> is less than 800 kg</i> )	Does boat capsize or swamp?		PASS/FAIL		
7 continued	Offset-load test: ( <i>options 1, 2, 4 – 6 only</i> )					
	testing for least stability: maximum heel angle	degrees	<			
	testing for least freeboard: heeled freeboard margin	mm	≥			
	maximum crew limit for stability					n/a
	maximum crew limit for freeboard					n/a
8	Heel due to wind: ( <i>options 1 to 6</i> ) Boats assessed in offset-load test condition.					
	Is ratio $A_{LV}/(L_H B_H) > 0,5$ ?			YES/NO	n/a	
	If YES:	at $m_{LA}$ : heel angle due to wind	degrees	<		
		at $m_{MO}$ : heel angle due to wind	degrees	<		
9	Flotation test: ( <i>options 1, 6, 8 and 9 only</i> ) all preparations completed?					
	For level flotation assess items marked <sup>a</sup> , for basic flotation those marked <sup>b</sup>				YES/NO	
	Swamped stability <sup>a</sup> :	5 min after swamping, does boat heel less than 45°?		PASS/FAIL		
	Load test <sup>ab</sup> :	5 min after swamping, does boat float as required?		PASS/FAIL		
	One person test <sup>a</sup> :	5 min after swamping, does boat float so that it can be bailed?		PASS/FAIL		
	Flotation elements <sup>ab</sup> :	Do all elements comply with all the requirements?		PASS/FAIL		
10	Basic flotation by calculation: ( <i>option 11</i> )		value of $m_{TEST}/V_B$	< 850		
			( <i>options 6, 8 or 9</i> )	value of $m_{TEST}/V_B$	< 930	
11	Capsize recovery test: ( <i>options 3 + 7 only</i> ) Are all requirements met?					
	Design category recommended by the builder				PASS/FAIL	
12	Knockdown recovery test: ( <i>options 8 + 10 only</i> )					
	method used = experimental or theoretical?				PASS/FAIL?	
13	Wind stiffness test: ( <i>options 9 + 11 only</i> )		Cat. C $v_W =$	m/s	≥ 11	
			Cat. D $v_W =$	m/s	≥ 6	
14	Detection & removal of water: ( <i>all options</i> )		Are all requirements met?		PASS/FAIL	
NB: Boat must pass all requirements applicable to option to be given intended design category.						
Design category given:			Assessed by:			

## Annex I (informative)

### Illustration of recess retention level

The term 'recess retention level' is defined in [clause 3.4.9](#) as:

“level of water in recesses, when the boat is at design trim, at which 20% of the uppermost periphery of the surrounding coaming (measured in horizontal plane parallel to waterline at design trim) would be covered by water, assuming that all gates, doors or drainage openings are considered to be sealed.”

The following figures illustrate this definition.

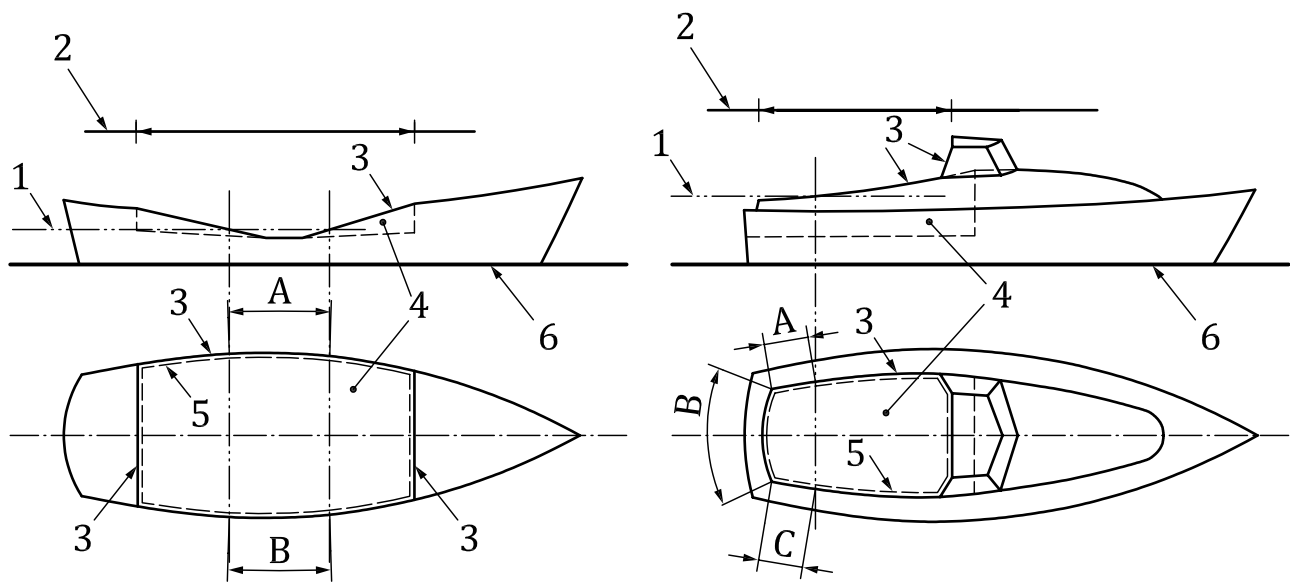

**A + B = 20% of length of periphery of coaming measured in horizontal plane parallel to waterline at design trim.**

**Example A**

**A + B + C = 20% of length of periphery of coaming measured in horizontal plane parallel to waterline at design trim.**

**Example B**

**Key**

- 1 recess retention level
- 2 horizontal plane parallel to waterline at design trim (6)
- 3 uppermost edge of coaming
- 4 recess
- 5 uppermost periphery of coaming measured in horizontal plane parallel to waterline at design trim
- 6 waterline at design trim

**Figure I.1 — Recess retention level**



## Bibliography

- [1] ISO 6185, (all parts), *Inflatable boats*
- [2] ISO 13590:1997, *Small craft — Personal watercraft — Construction and system installation requirements*
- [3] IMO Resolution MSC.81(70), *Revised Recommendation on Testing of Life-Saving Appliances*
- [4] ISO 7010, *Graphical symbols — Safety colours and safety signs — Registered safety signs*

