**Small craft — Stability and buoyancy
assessment and categorization —**

**Part 2:
Sailing boats of hull length greater than
or equal to 6 m**

*Petits navires — Évaluation et catégorisation de la stabilité et de la
flottabilité —*

*Partie 2: Bateaux à voiles d'une longueur de coque supérieure ou égale
à 6 m*





COPYRIGHT PROTECTED DOCUMENT

© ISO 2013

All rights reserved. Unless otherwise specified, no part of this publication may be reproduced or utilized in any form or by any means, electronic or mechanical, including photocopying and microfilm, without permission in writing from either ISO at the address below or ISO's member body in the country of the requester.

ISO copyright office
Case postale 56 • CH-1211 Geneva 20
Tel. + 41 22 749 01 11
Fax + 41 22 749 09 47
E-mail copyright@iso.org
Web www.iso.org

Published in Switzerland

Contents

Page

Foreword	v
Introduction	vi
1 Scope	1
2 Normative references	1
3 Terms and definitions	2
3.1 Primary	2
3.2 Hazards	4
3.3 Downflooding	4
3.4 Dimensions, areas and angles	5
3.5 Condition, mass and volume	6
3.6 Other terms and definitions	9
4 Symbols	11
5 Procedure	13
5.1 Maximum load	13
5.2 Sailing or non-sailing	13
5.3 Tests, calculations and requirements to be applied	13
5.4 Variation in input parameters	13
6 Requirements for monohull boats	13
6.1 Requirements to be applied	13
6.2 Downflooding	14
6.3 Recess size	18
6.4 Minimum righting energy	21
6.5 Angle of vanishing stability	21
6.6 Stability index (STIX)	23
6.7 Knockdown-recovery test	26
6.8 Wind stiffness test	27
6.9 Flotation requirements	30
6.10 Capsize-recovery test	30
6.11 Detection and removal of water	32
7 Requirements for catamarans, trimarans and form-stable monohulls	33
7.1 Requirements to be applied	33
7.2 Downflooding openings	33
7.3 Downflooding height	33
7.4 Recess size	33
7.5 Stability information	33
7.6 Safety signs	34
7.7 Bare poles factor	35
7.8 Rolling in breaking waves	35
7.9 Pitchpoling	36
7.10 Diagonal stability	36
7.11 Habitable multihull boats	36
7.12 Buoyancy when inverted	38
7.13 Escape after inversion	38
8 Safety signs	39
9 Application	40
9.1 Deciding the design category	40
9.2 Meaning of the design categories	40
Annex A (normative) Full method for required downflooding height	42
Annex B (normative) Methods for calculating downflooding angle	44
Annex C (normative) Determining the curve of righting moments	47

Annex D (normative) Method for calculating reserve of buoyancy after inversion or swamping	50
Annex E (normative) Flotation material and elements	52
Annex F (normative) Information for owner's manual	54
Annex G (normative) Determination of safe wind speed information	58
Annex H (normative) Determination of longitudinal righting characteristics	61
Annex I (informative) Summary of requirements	64
Annex J (informative) Worksheets	67
Bibliography	86

Foreword

ISO (the International Organization for Standardization) is a worldwide federation of national standards bodies (ISO member bodies). The work of preparing International Standards is normally carried out through ISO technical committees. Each member body interested in a subject for which a technical committee has been established has the right to be represented on that committee. International organizations, governmental and non-governmental, in liaison with ISO, also take part in the work. ISO collaborates closely with the International Electrotechnical Commission (IEC) on all matters of electrotechnical standardization.

International Standards are drafted in accordance with the rules given in the ISO/IEC Directives, Part 2.

The main task of technical committees is to prepare International Standards. Draft International Standards adopted by the technical committees are circulated to the member bodies for voting. Publication as an International Standard requires approval by at least 75 % of the member bodies casting a vote.

Attention is drawn to the possibility that some of the elements of this document may be the subject of patent rights. ISO shall not be held responsible for identifying any or all such patent rights.

ISO 12217-2 was prepared by Technical Committee ISO/TC 188, *Small craft*.

This second edition cancels and replaces the first edition (ISO 12217-2:2002), which has been technically revised.

ISO 12217 consists of the following parts, under the general title *Small craft — Stability and buoyancy assessment and categorization*:

- *Part 1: Non-sailing boats of hull length greater than or equal to 6 m*
- *Part 2: Sailing boats of hull length greater than or equal to 6 m*
- *Part 3: Boats of hull length less than 6 m*

Introduction

This part of ISO 12217 enables the determination of limiting environmental conditions for which an individual boat has been designed.

It enables the boat to be assigned to a design category appropriate to its design and maximum load. The design categories used align with those in the Recreational Craft Directive of the European Union, EU Directive 94/25/EC as amended by Directive 2003/44/EC.

Annex J provides worksheets to assist in the systematic assessment of a boat according to this part of ISO 12217.

Small craft — Stability and buoyancy assessment and categorization —

Part 2: Sailing boats of hull length greater than or equal to 6 m

CAUTION — Compliance with this part of ISO 12217 does not guarantee total safety or total freedom of risk from capsize or sinking.

IMPORTANT — The electronic file of this document contains colours which are considered to be useful for the correct understanding of the document. Users should therefore consider printing this document using a colour printer.

1 Scope

This part of ISO 12217 specifies methods for evaluating the stability and buoyancy of intact (i.e. undamaged) boats. The flotation characteristics of boats vulnerable to swamping are also encompassed.

The evaluation of stability and buoyancy properties using this part of ISO 12217 will enable the boat to be assigned to a design category (A, B, C or D) appropriate to its design and maximum load.

This part of ISO 12217 is principally applicable to boats propelled primarily by sail (even if fitted with an auxiliary engine) of 6 m up to and including 24 m hull length. However, it can also be applied to boats less than 6 m if they are habitable multihulls or may be applied if they do not attain the desired design category specified in ISO 12217-3 and they are decked and have quick-draining recesses which comply with ISO 11812.

In relation to habitable multihulls, this part of ISO 12217 includes assessment of vulnerability to inversion, definition of viable means of escape and requirements for inverted flotation.

This part of ISO 12217 excludes:

- inflatable and rigid-inflatable boats covered by ISO 6185, except for references made in ISO 6185 to specific clauses of ISO 12217;
- gondolas and pedalos;
- surfboards including sailing surfboards; and
- hydrofoils and foil stabilized boats when not operating in the displacement mode.

NOTE Displacement mode means that the boat is only supported by hydrostatic forces.

It does not include or evaluate the effects on stability of towing, fishing, dredging or lifting operations, which need to be separately considered if appropriate.

2 Normative references

The following referenced documents are indispensable for the application of this document. For dated references, only the edition cited applies. For undated references, the latest edition of the referenced document (including any amendments) applies.

ISO 2896:2001, *Rigid cellular plastics — Determination of water absorption*

ISO 3864-1, *Graphical symbols – Safety colours and safety signs – Part 1: Design principles for safety signs and safety markings*

ISO 8666, *Small craft — Principal data*

ISO 9093-1, *Small craft — Seacocks and through-hull fittings — Part 1: Metallic*

ISO 9093-2, *Small craft — Seacocks and through-hull fittings — Part 2: Non-metallic*

ISO 9094 (all parts), *Small craft — Fire protection*

ISO 10240, *Small craft — Owner's manual*

ISO 11812, *Small craft — Watertight cockpits and quick-draining cockpits*

ISO 12216, *Small craft — Windows, portlights, hatches, deadlights and doors — Strength and watertightness requirements*

ISO 12217-1:2013, *Small craft — Stability and buoyancy assessment and categorization — Part 1: Non-sailing boats of hull length greater than or equal to 6 m*

ISO 12217-3:2013, *Small craft — Stability and buoyancy assessment and categorization — Part 3: Boats of hull length less than 6 m*

ISO 14946, *Small craft — Maximum load capacity*

ISO 15083, *Small craft — Bilge-pumping systems*

3 Terms and definitions

For the purposes of this document, the following terms and definitions apply.

NOTE The meanings of certain symbols used in the definitions are given in Clause 4.

3.1 Primary

3.1.1 design category

description of the sea and wind conditions for which a boat is assessed to be suitable by this part of ISO 12217

NOTE See also 9.2.

3.1.2 sailing boat

boat for which the primary means of propulsion is by wind power, having reference sail area (3.4.8)
 $A_S \geq 0,07(m_{LDC})^{2/3}$

NOTE m_{LDC} is the mass of the boat in the maximum load condition, expressed in kilograms.

3.1.3 catamaran

boat with two main load-bearing hulls

EXAMPLE Boats with a centreline or bridge-deck nacelle which supports less than 30 % of the mass in the maximum load condition are considered to be catamarans. Proas are asymmetric catamarans.

3.1.4 trimaran

boat with a centre main hull and two sidehulls in which the centre hull, when the boat is upright, supports 30 % or more of the mass in the maximum load condition

3.1.5 recess

volume open to the air that might retain water within the range of loading conditions and corresponding trims

EXAMPLE Cockpits, wells, open volumes or areas bounded by bulwarks or coamings.

NOTE 1 Cabins, shelters or lockers provided with closures according to the requirements of ISO 12216 are not recesses.

NOTE 2 Cockpits that are open aft to the sea are considered to be recesses. Flush decks without bulwarks or coamings are not recesses.

3.1.6 quick-draining recess

recess fulfilling all the requirements of ISO 11812 for “quick-draining cockpits and recesses”

NOTE 1 According to its characteristics, a cockpit may be considered to be quick-draining for one design category, but not for a higher category.

NOTE 2 ISO 11812 contains requirements with which most sailing dinghies cannot comply.

3.1.7 watertight recess

recess fulfilling all the requirements of ISO 11812 for “watertight cockpits and recesses”

NOTE This term only implies requirements in respect of watertightness and sill heights, but not those for drainage.

3.1.8 fully enclosed boat

boat in which the horizontal projection of the sheerline area comprises any combination of

- watertight deck and superstructure, and/or
- quick-draining recesses which comply with ISO 11812, and/or
- watertight recesses complying with ISO 11812 with a combined volume of less than $(L_H B_H F_M)/40$, and

all closing appliances have their degree of watertightness in accordance with ISO 12216

NOTE The size of recesses permitted for boats of design category A, B or some boats of design category C is restricted by the requirements of 6.3.

3.1.9 habitable boat

boat having a fully enclosed cabin with rigid roof fitted with one or more bunks, benches, pipecots, hammocks or similar locations that can be used for sleeping when the boat is under way

NOTE 1 A boat is considered to be “habitable” if a fabric closure is used instead of a rigid door, or the cabin has fabric sides.

NOTE 2 The following are not considered to render a boat “habitable”:

- a cockpit tent, or
- an open-sided cuddy intended to provide limited protection from spray, provided it is not fitted with fabric closures all round.

NOTE 3 Locations used for sleeping have minimum dimensions of 1,5 m diagonal length, 0,4 m width at the widest point, and with a minimum headroom of 0,4 m over the length. The cabin sole and compartments designated by the builder to be used exclusively for storage and referenced in the owner’s manual are not included.

3.1.10 habitable part of a boat

spaces within a habitable boat with rigid roof that are fitted with a toilet or in which there is provision for any of the following activities: sitting, sleeping, cooking, eating, washing, navigation, steering

NOTE Compartments designated by the builder to be used exclusively for storage and referenced in the owner’s manual are not included.

3.2 Hazards

3.2.1

capsize

event when a boat reaches any heel angle from which it is unable to recover to equilibrium near the upright without intervention

3.2.2

knockdown

event when a boat reaches a heel angle sufficient to immerse the masthead, and from which it may or may not recover without intervention

3.2.3

inversion

event when a boat becomes upside down

3.3 Downflooding

3.3.1

downflooding opening

opening in the hull or deck (including the edge of a recess) that might admit water into the interior or bilge of a boat, or a recess, apart from those excluded in 6.2.1.6

3.3.2

downflooding angle

ϕ_D
angle of heel at which downflooding openings (apart from those excluded in 6.2.1.6) become immersed, when the boat is in calm water and in the appropriate loading condition at design trim

NOTE 1 Where openings are not symmetrical about the centreline of the boat, the case resulting in the smallest angle is used.

NOTE 2 The following are specifically considered:

- ϕ_D is the downflooding angle to any downflooding opening
- ϕ_{DA} is the angle of heel at which openings which are not marked "KEEP SHUT WHEN UNDER WAY" having a combined total area, expressed in square centimetres (cm²), greater than the number represented by $1,2L_H B_H F_M$ first become immersed;
- ϕ_{DC} is the downflooding angle at which recesses which are not quick-draining begin to fill with water;
- ϕ_{DH} is the downflooding angle at which any main access hatch (i.e. having an opening area greater than 0,18 m² each) giving direct access to the main open air helm position first begins to become immersed.

NOTE 3 Downflooding angle is expressed in degrees.

3.3.3

downflooding height

h_D
smallest height above the waterline to any downflooding opening, apart from those excluded in 6.2.1.6, when the boat is upright in calm water and in the maximum load condition, measured to the critical downflooding point which might be within pipes or ducts inside the hull

NOTE 1 Downflooding height is expressed in metres.

NOTE 2 See Figure B.1

3.4 Dimensions, areas and angles

3.4.1

length of hull

L_H

length of the hull measured according to ISO 8666

NOTE Length of hull is expressed in metres.

3.4.2

length waterline

L_{WL}

waterline length measured according to ISO 8666 when the boat is upright in calm water, in the appropriate loading condition and at design trim

NOTE 1 For multihull boats, L_{WL} relates to that of the longest individual hull.

NOTE 2 Length waterline is expressed in metres.

3.4.3

beam of hull

B_H

maximum beam of the hull using the method of ISO 8666; for catamaran and trimaran boats, maximum beam across the outer hulls

NOTE Beam of hull is expressed in metres.

3.4.4

beam waterline

B_{WL}

greatest beam measured according to ISO 8666 at the waterline in calm water which, for multihull boats, is the sum of the maximum waterline beams of each of the hulls, the boat being upright, in the appropriate loading condition and at design trim

NOTE Beam waterline is expressed in metres.

3.4.5

beam between hull centres

B_{CB}

on catamaran and trimaran boats, the transverse distance between the centres of buoyancy of the outer hulls

NOTE Beam between hull centres is expressed in metres.

3.4.6

freeboard amidships

F_M

distance of the sheerline or deck above the waterline at $L_{WL}/2$ measured according to ISO 8666, the boat being upright, in the appropriate loading condition and at design trim

NOTE 1 Freeboard amidships is expressed in metres.

NOTE 2 Where no loading condition is specified, maximum load condition should be assumed.

3.4.7

draught of canoe body

T_C

draught of the main buoyant part of the hull(s) below the waterline, as defined in ISO 8666, the boat being upright in the appropriate loading condition and at design trim

NOTE Draught of canoe body excludes appendages such as rudders or skegs, and is expressed in metres.

**3.4.8
reference sail area**

A_s
actual profile area of sails set abaft a mast, plus the maximum profile areas of all masts, plus reference triangle area(s) forward of each mast as defined in ISO 8666

NOTE Sail area is expressed in square metres.

**3.4.9
standard sail area**

$A's$
actual profile area of the largest sail plan suitable for windward sailing in true winds of 10–12 kn (5,1–6,2 m/s), including overlaps, and supplied or recommended by the builder as standard

NOTE Sail area is expressed in square metres.

**3.4.10
angle of vanishing stability**

ϕ_v
angle of heel nearest the upright (other than upright) in the appropriate loading condition at which the transverse stability righting moment is zero

NOTE 1 This is determined assuming that there is no offset load, and that all potential downflooding openings are considered to be watertight.

NOTE 2 Where a boat has recesses which are not quick-draining, ϕ_v is to be taken as the downflooding angle to these recesses, unless the loss of buoyancy due to such recesses is fully accounted for in determining ϕ_v .

NOTE 3 Angle of vanishing stability is expressed in degrees.

3.5 Condition, mass and volume

**3.5.1
empty craft condition**

empty boat including fittings and equipment as listed below but excluding all optional equipment and fittings not included in the manufacturer's basic outfit:

- a) structure: comprising all the structural parts, including any fixed ballast keel and/or drop keel/centreboard/daggerboard(s) and rudder(s);
- b) ballast: any fixed ballast installed;
- c) internal structure and accommodation: bulkheads and partitions, insulation, lining, built-in furniture, flotation material, windows, hatches and doors, permanently installed mattresses and upholstery materials;
- d) permanently installed engine(s) and fuel system: comprising inboard engine(s), including all supplies and controls as needed for their operation, permanently installed fuel systems, including tanks;
- e) fluids in permanently installed systems: residual working fluids as needed for their operation (see examples below), but excluding contents of fluid ballast systems and tanks, and main storage tanks (which are included in maximum load);

EXAMPLES: fluids in hot or cold water, fuel, lubricating or hydraulic oil systems

- f) internal equipment, including:
 - all items of equipment permanently attached to the craft, e.g. tanks, toilet system(s), water transfer equipment;
 - bilge pumping system(s), cooking and heating devices, cooling equipment, ventilation system(s);
 - electrical installation and equipment, including permanently installed batteries mounted in the position intended by the builder;

- fixed navigational and electronic equipment;
- fixed fire fighting equipment, where fitted;

g) external equipment, including:

- all permanently attached standard or specified deck fittings, e.g. guardrails, pulpits and pushpits, bowsprits and their attachments, bathing platforms, boarding ladders, steering equipment, winches, sprayhood(s);
- awning(s), cockpit tables, gratings, signal mast(s), where fitted;
- mast(s), boom(s), spinnaker poles and other pole(s), standing and running rigging, in the stowed position ready for use; all standing and running rigging in place

NOTE The mass in the empty craft condition is denoted by m_{EC} and is expressed in kilograms.

3.5.2 light craft condition

empty craft condition plus standard equipment (3.6.12) plus removable ballast (whether solid or liquid) when supplied and/or intended by the manufacturer to be carried when the boat is afloat, with elements positioned as follows:

- a) where provision is made for propulsion by outboard engine(s) of more than 3 kW, the heaviest engine(s) recommended for the boat by the manufacturer is(are) mounted in the working position(s);
- b) where batteries are fitted, they are mounted in the position intended by the builder, and if there is no specific stowage provided for batteries, the mass of one battery for each engine over 7 kW is allowed for, and located within 1,0 m of the engine location.
- c) all upwind sails supplied or recommended by the builder as standard, onboard and rigged ready for use, but not hoisted, e.g. mainsail on boom, roller furling sails furled, hanked foresails on stay stowed on foredeck

NOTE 1 For the minimum mass of outboard engines and batteries, refer to Tables C.1 and C.2 of ISO 12217-3:2013.

NOTE 2 The mass in the light craft condition is denoted by m_{LC} and is expressed in kilograms.

3.5.3 minimum operating condition

boat in the light craft condition with the following additions:

- a) mass to represent the crew, positioned on the centreline near the main control position of:
 - 75 kg where $L_H \leq 8$ m,
 - 150 kg where $8 \text{ m} < L_H \leq 16$ m,
 - 225 kg where $16 \text{ m} < L_H \leq 24$ m;
- b) non-edible stores and equipment normally carried on the boat and not included in the manufacturer's list of standard equipment;

EXAMPLES Loose internal equipment and tools, spare parts, dishes, kitchenware and cutlery, additional anchors or sails, dinghy and outboard if carried aboard.

NOTE 1 Liquids in main storage tanks (e.g. fuel, drinking water, black and grey water, live wells, bait tanks, etc.) are excluded.

NOTE 2 Water ballast in tanks which are symmetrical about the centreline and which are intended by the builder to be used for variable asymmetric ballasting while under way is excluded.

NOTE 3 Elements with transversally variable position (e.g. canting keels, movable solid ballast, tilting masts) are positioned symmetrically about the centreline of the boat. Elements with longitudinally variable position (eg: tilting masts or keels) are positioned so that the VCG is maximized.

NOTE 4 Any centreboard or keel is in the raised position unless it can be fixed in the lowered position and an appropriate instruction is given in the owner's manual.

NOTE 5 The mass in the minimum operating condition is denoted by m_{MO} and is expressed in kilograms.

3.5.4

maximum load

load which the boat is designed to carry in addition to the light craft condition, comprising:

- the crew limit at 75 kg each;
- the personal effects of the crew;
- stores and cargo (if any), dry provisions, consumable liquids;
- contents of all permanently installed storage tanks filled to 95 % of their maximum capacity, including fuel, drinking water, black water, grey water, lubricating and hydraulic oil, bait tanks and/or live wells; plus ballast water at 100 % capacity;
- consumable liquids in portable tanks (drinking water, fuel) filled to 95 % of the maximum capacity;
- dinghy or other small craft intended to be carried aboard, and any outboard motor associated with them;
- liferaft(s) if carried in excess of the minimum required in essential safety equipment;
- non-edible stores and equipment normally carried on the boat and not included in the manufacturer's list of standard equipment, e.g. loose internal equipment and tools, spare parts, additional anchors or sails, dinghy and outboard if carried aboard;
- an allowance for the maximum mass of optional equipment and fittings not included in the manufacturer's basic outfit

NOTE 1 Liferafts are not included in essential safety equipment for Categories C and D.

NOTE 2 As a guide, not less than 20 kg per person should be allowed for personal effects on habitable boats.

NOTE 3 As a guide, the mass of yachting liferafts varies from approximately $12 + 2CL$ (kg) to double this, according to specification.

NOTE 4 Unless otherwise required, variable position elements (e.g. canting keels, movable solid ballast, tilting masts) are positioned symmetrically about the centreline of the boat.

NOTE 5 Any centreboard or keel is in the raised position unless it can be fixed in the lowered position and an appropriate instruction is given in the owner's manual.

NOTE 6 The mass of maximum load is denoted by m_L and is expressed in kilograms.

3.5.5

maximum load condition

boat in the light craft condition with the maximum load added so as to produce the design trim

NOTE The mass in the maximum load condition is denoted by m_{LDC} and is expressed in kilograms.

3.5.6

loaded arrival condition

boat in the maximum load condition minus 85 % of the maximum capacity of fixed or portable storage tanks for fuel, oils and drinking water, and minus 90 % of edible stores, but including the worst combination of optional fittings or equipment with respect to stability

NOTE 1 The mass in the loaded arrival condition is denoted by m_{LA} and is expressed in kilograms.

NOTE 2 Unless otherwise required, variable position elements (e.g. canting keels, movable solid ballast, tilting masts) are positioned symmetrically about the centreline of the boat.

3.5.7**displacement volume** V_D

volume of displacement of the boat that corresponds to the appropriate loading condition, taking the density of water as 1 025 kg/m³

NOTE Displacement volume is expressed in cubic metres.

3.6 Other terms and definitions**3.6.1****calculation wind speed** v_W

wind speed used in calculations

NOTE Calculation wind speed is expressed in metres per second or in knots.

3.6.2**crew**

collective description of all persons onboard a boat

3.6.3**crew limit****CL**

maximum number of persons (with a mass of 75 kg each) used when assessing the design category

3.6.4**design trim**

longitudinal attitude of a boat when upright, with crew, fluids, stores and equipment in the positions designated by the designer or builder

NOTE Crew are assumed to be in positions designated by the builder. In the absence of builder's instructions, crew and gear are assumed to be positioned in a manner most likely to provide a favourable test result, provided that such positions are consistent with the proper operation of the boat and that crew are assumed to be either standing at designated positions fitted with handholds, or seated.

3.6.5**essential safety equipment**

loose equipment considered essential to the safe operation of the boat, which may include distress flares and rockets, lifebuoy with light and battery, first aid box, wire cutters for standing rigging, lifejackets, safety harnesses and lines, portable firefighting equipment, flashlight, binoculars, radio (e.g. VHF), ball and cone visual signals, charts, navigational publications and for design categories A and B, liferaft(s) sufficient for the crew limit in the corresponding design category

NOTE 1 Quantities carried may vary according to the size of boat, design category and crew limit.

NOTE 2 As a guide, the mass allowed for essential safety equipment but excluding any liferaft(s) should not be less than $3L_H$ (kg).

NOTE 3 The mass of yachting liferafts varies from approximately $12 + 2CL$ (kg) to double this, according to specification.

NOTE 4 Liferafts are not considered to be essential safety equipment in design categories C and D.

3.6.6**flotation element**

element which provides buoyancy to the boat and thus influences the flotation characteristics

3.6.6.1**air tank**

tank made of hull construction material, and integral with hull or deck structure

3.6.6.2

air container

container made of stiff material, and not integral with the hull or deck structure

3.6.6.3

low density material

material with a specific gravity of less than 1,0 primarily incorporated into the boat to enhance the buoyancy when swamped

3.6.6.4

inflated bag

bag made of flexible material, not integral with hull or deck, accessible for visual inspection and intended always to be inflated when the boat is being used

NOTE Bags intended to be inflated automatically when immersed (e.g. at the masthead as a means to prevent inversion) are not regarded as flotation elements.

3.6.7

inclining experiment

method by which the vertical position of the centre of gravity (VCG) of a boat can be determined

NOTE 1 The VCG, together with a knowledge of the shape of the hull (the lines plan) and the position of the waterline in a known loading condition, enable all the intact stability parameters to be calculated.

NOTE 2 A full description of how to conduct an inclining experiment is given in standard naval architecture textbooks, e.g. references [2] and [3] in the bibliography.

3.6.8

righting lever

GZ

at a specific heel (or trim) angle in calm water, the distance in both the horizontal and transverse (or horizontal and longitudinal) planes between the centre of buoyancy and the centre of gravity

NOTE 1 Righting lever usually refers to the transverse plane, but may be in the longitudinal plane where longitudinal stability is concerned.

NOTE 2 Righting lever is equal to the righting moment divided by the product of mass, expressed in kilograms, and acceleration due to gravity ($9,806 \text{ m/s}^2$) and is expressed in metres.

3.6.9

righting moment

RM

at a specific heel (or trim) angle in calm water, the restoring moment generated by the transverse (or longitudinal) offset of the centre of buoyancy of the submerged part of the hull from the centre of gravity of the boat

NOTE 1 Righting moment usually refers to the transverse plane, but may be in the longitudinal plane where longitudinal stability is concerned.

NOTE 2 The righting moment varies with heel (or trim) angle and is usually plotted graphically against heel (or trim) angle. Righting moments are most accurately derived by computer from a knowledge of the hull shape and the location of the centre of gravity. Other more approximate methods are also available. The righting moment varies substantially with hull form, centre of gravity position, boat mass and trim attitude.

NOTE 3 Righting moment is expressed in newton metres or kilonewton metres.

3.6.10

loaded waterline

waterline of the boat when upright in the maximum load condition

3.6.11**recess retention level**

level of water in recesses, other than those described by 6.3.1 a) to d), at which the unobstructed drainage area when the boat is in the loaded arrival condition and at design trim exceeds 5 % of the volume of the recess to the lowest point of the peripheral coaming, assuming any gates or doors are sealed

NOTE The area of drainage openings is expressed in square metres and the volume is expressed in cubic metres.

3.6.12**standard equipment**

devices including outboard motors (excluding those for tenders), loose furniture and furnishings such as tables, chairs, non-permanently installed mattresses, curtains, etc., portable bilge pumping equipment anchors, chain, warps, sails, loose external equipment such as fenders, boathook and boarding ladder, oars (if appropriate), and essential safety equipment

NOTE 1 Where outboard engine(s) are fitted, the heaviest engine(s) recommended for the boat by the manufacturer is(are) included, the mass allowed for outboard engines and their batteries (if not permanently installed) not being less than that given in columns 1 and 3 of Tables F.1 and F.2 of ISO 12217-1:2013 or Tables B.1 and B.2 of ISO 12217-3:2013.

NOTE 2 As a guide, the mass allowed for anchors, anchor chain, warps and fenders should not be less than about $0,25L_H^{2,2}$ (kg). In some cases up to double this mass may be appropriate.

3.6.13**watertightness degree**

degree of watertightness as specified in ISO 11812 and ISO 12216

NOTE The degree of watertightness is summarized as follows.

Degree 1: Degree of tightness providing protection against effects of continuous immersion in water.

Degree 2: Degree of tightness providing protection against effects of temporary immersion in water.

Degree 3: Degree of tightness providing protection against splashing water.

Degree 4: Degree of tightness providing protection against water drops falling at an angle of up to 15° from the vertical.

3.6.14**under way**

not at anchor, or made fast to the shore, or aground

4 Symbols

For the purposes of this document, the symbols and associated units in Table 1 apply.

Table 1 — Symbols

Symbol	Unit	Meaning
ϕ	degree (°)	Angle of heel
ϕ_D	degree (°)	Actual downflooding angle of any downflooding opening, see 3.3.2
$\phi_{D(R)}$	degree (°)	Required downflooding angle, see 6.2.3
ϕ_{DA}	degree (°)	Downflooding angle at which a certain total area of openings is submerged, see 3.3.2
ϕ_{DC}	degree (°)	Downflooding angle to cockpits that are not quick-draining according to ISO 11812, see 3.3.2
ϕ_{DH}	degree (°)	Downflooding angle to any main access hatchway, see 3.3.2
ϕ_{GZmax}	degree (°)	Angle of heel at which maximum righting moment or lever occurs
ϕ_V	degree (°)	Angle of vanishing stability, see 3.4.10
$\phi_{V(R)}$	degree (°)	Required angle of vanishing stability, see 6.5
A_{GZ}	m · degree	Positive area under righting lever curve, see 6.4 and 6.6.2

Table 1 (continued)

Symbol	Unit	Meaning
A_S	m ²	Reference sail area according to ISO 8666 and 3.4.8
$A'S$	m ²	Standard sail area, see 3.4.9
B_{CB}	m	Beam between centres of buoyancy of sidehulls, see 3.4.5
B_H	m	Beam of hull according to ISO 8666
B_{WL}	m	Beam waterline in the appropriate loading condition according to ISO 8666 and 3.4.4. In the case of multihulls, it is the sum of the maximum waterline beams of each of the hulls.
CL		Crew limit = maximum number of persons on board, see 3.6.3
F_M	m	Freeboard amidships at the appropriate loading condition according to 3.4.7
GM_T	m	Transverse metacentric height, see 6.3
GZ	m	Righting lever = righting moment (N·m)/[mass (kg) × 9,806], see 3.6.8
GZ ₉₀	m	Righting lever at 90° heel
h_{CE}	m	Height of centre of area of A_S above waterline at the appropriate loading condition, see 6.8
h'_{CE}	m	Height of centre of area of $A'S$ above waterline at the appropriate loading condition, see 6.8
h_D	m	Actual downflooding height, see 3.3.3
$h_{D(R)}$	m	Required downflooding height, see 6.2.2
h_{LP}	m	Height of waterline at the appropriate loading condition above centre of area of immersed profile area including keel(s) and rudder(s), see 6.8.2 and 6.8.3
L_{BS}	m	Length base size = $(2L_{WL} + L_H)/3$
LCG	m	Longitudinal position of the centre of gravity from a chosen datum
L_H	m	Length of hull according to ISO 8666
L_{WL}	m	Length of waterline at the appropriate loading condition according to ISO 8666
m	kg	Mass of the boat, used where more than one loading condition is considered
m_{EC}	kg	Mass of the boat in the empty craft condition, see 3.5.1
m_L	kg	Mass of the maximum load, see 3.5.4
m_{LA}	kg	Mass of the boat in the loaded arrival condition, see 3.5.6
m_{LC}	kg	Mass of the boat in light craft condition, see 3.5.2
m_{LDC}	kg	Mass of the boat in maximum load condition, see 3.5.5
m_{MO}	kg	Mass of the boat in the minimum operating condition, see 3.5.3
RM	N·m	Righting moment, see 3.6.9
STIX	—	Actual stability index value at the appropriate loading condition according to 6.6
STIX _(R)	—	Required stability index value, see Table 6
T_C	m	Draught of canoe body at the appropriate loading condition according to ISO 8666
VCG	m	Vertical position of the centre of gravity from a chosen datum
V_D	m ³	Displacement volume, see 3.5.7
V_R	m ³	Volume of a non-quick-draining recess, see Annex A
v_W	m/s	Calculation wind speed, see 3.6.1
x_D	m	Longitudinal distance of downflooding opening from nearest extremity of L_H
x'_D	m	Longitudinal distance of downflooding opening from forward end of L_H
y_D	m	Transverse distance of downflooding opening from periphery of boat
y'_D	m	Transverse distance of downflooding opening off centreline
z_D	m	Height above waterline of downflooding opening

5 Procedure

5.1 Maximum load

Decide on the crew limit and the maximum load that the boat is intended to carry in accordance with the definitions. The crew limit shall not exceed that determined by the seating or standing space requirements of ISO 14946.

IMPORTANT — Ensure that the maximum load is not underestimated.

NOTE If a boat is assessed with different amounts of maximum load, different design categories may be assigned according to the load.

5.2 Sailing or non-sailing

Confirm that the boat is defined as sailing. Sailing boats are those where $A_S \geq 0,07 \times (m_{LDC})^{2/3}$, where A_S is the reference sail area according to 3.4.8 and ISO 8666 and m_{LDC} is the mass of the boat in the maximum load condition, as defined in 3.5.5 and expressed in kilograms.

Other boats are non-sailing boats and shall be assessed using ISO 12217-1.

5.3 Tests, calculations and requirements to be applied

Clause 6 shall be applied to monohull sailing boats.

Clause 7 shall be applied to catamaran or trimaran sailing boats.

NOTE Monohulls applying 6.5.2 (form-stable monohulls) are required to comply with some requirements of Clause 7.

All the requirements of the option chosen from Clause 6 or 7 shall be satisfied.

5.4 Variation in input parameters

Users of this part of ISO 12217 shall consider the effect on compliance of variations in the empty craft mass within the builder's manufacturing tolerances.

6 Requirements for monohull boats

6.1 Requirements to be applied

6.1.1 Monohull sailing boats shall comply with all the requirements of any one of seven options according to amount of flotation and decking, and whether the boat is fitted with suitable recesses. These options and the tests to be applied are given in Table 2.

NOTE For any given test, the requirements may vary according to the chosen option, e.g. for downflooding height.

6.1.2 The design category finally given is that for which the boat satisfies all the relevant requirements of any one of these options. See Annex I.

6.1.3 For boats using option 1 or 2, each of the requirements shall be satisfied in the minimum operating condition and in the loaded arrival condition unless otherwise specifically noted. In calculating the position of the overall centre of gravity in the loaded arrival condition, the following shall be observed:

- fluids shall be located in the fixed tanks;
- provisions shall be stowed in an appropriate location;
- the mass of additional crew (crew limit less those required for m_{MO}) shall be added at sheerline height at the mid-length of L_H .

6.1.4 Boats fitted with provision for asymmetric ballasting while under way (whether liquid or solid) shall

- a) comply with all the requirements of the selected option as indicated in Table 2, and
- b) comply with the requirements of 6.2.3, 6.4 (if appropriate), 6.5 and 6.6 considering that the movable ballast is of whichever amount and position that gives the most adverse result when considering each individual stability requirement.

Table 2 — Requirements to be applied to monohull sailing boats

Option	1	2	3	4	5	6	7
Categories possible	A and B	C and D	C and D	C and D	C and D	C and D	C and D
Decking or covering	Fully enclosed boat ^a	Fully enclosed boat ^a	Any boat except fully enclosed boat ^b	Any boat except fully enclosed boat ^b	Any boat	Any boat	Any boat except fully enclosed boat ^b
Downflooding openings	6.2.1	6.2.1	6.2.1	6.2.1	6.2.1	6.2.1	—
Downflooding-height test	6.2.2	6.2.2	6.2.2	—	6.2.2	—	—
Downflooding angle	6.2.3	6.2.3	—	—	—	—	—
Recess size	6.3 ^c	—	—	—	6.3 ^d	6.3 ^d	—
Minimum righting energy	6.4	—	—	—	—	—	—
Angle of vanishing stability	6.5	6.5	—	—	—	—	—
Stability index	6.6	6.6	—	—	—	—	—
Knockdown-recovery test	—	—	6.7	6.7	—	—	—
Wind stiffness test	—	—	—	—	6.8	6.8	—
Flotation requirements	—	—	—	6.9	—	6.9	—
Capsize recovery test	—	—	—	—	—	—	6.10
Detection and removal of water	6.11	6.11	6.11	6.11	6.11	6.11	6.11

^a This term is defined in 3.1.8.

^b That is, any boat that is not “fully enclosed”, thus including boats without any decking.

^c Only applicable to boats using 6.5.2 and having $\phi_V < 90^\circ$.

^d This requirement only applies to boats of design category C that are fully enclosed.

6.2 Downflooding

NOTE These requirements are to ensure that a level of watertight integrity appropriate to the design category is maintained.

6.2.1 Downflooding openings

6.2.1.1 All closing appliances (as defined in ISO 12216) such as windows, portlights, hatches, deadlights and doors shall comply with ISO 12216, according to design category and appliance location area.

Openings to centreboard or drop keel casings fitted to habitable sailing boats shall comply with the watertightness degree 3 if their height is less than that corresponding to Area I (as defined in ISO 12216).

6.2.1.2 No hatches or opening type windows shall be fitted in the hull with the lowest part of the opening less than 0,2 m (design category A, B or C) or 0,1 m (design category D) above the loaded waterline, except for emergency escape hatches on design category C boats, where 0,1 m is allowable.

6.2.1.3 Seacocks complying with ISO 9093-1 and ISO 9093-2, respectively, together with means of preventing flow into the boat when the seacock is open, shall be fitted to through-hull pipe fittings located with any part of the opening below either the heeled or upright waterline when fully loaded, apart from:

- a) engine exhausts, or

- b) drains forming an integral part of the hull and of equal strength and tightness extending from the outlet to above the fully loaded upright waterline at least 0,12 m for design category A, 0,08 m for design category B, 0,06 m for design category C or 0,04 m for design category D, and also above the heeled waterline defined as follows:
- 1) 7° for sailing multihulls, or
 - 2) 30° or immersion of the sheerline, whichever occurs first, for monohull sailing boats.

NOTE 1 Means of preventing flow into the boat may comprise:

- a pipe or hose extending above the heeled waterline, or
- a pipe or hose leading to a downflooding point above the heeled waterline, or
- a non-return valve, or
- a pipe or hose connected to a system that cannot flood the interior of the boat, or
- for seacocks not connected internally, a permanent cap or means of securing the seacock in the closed position

Instructions for the correct and safe operation of seacocks shall be included in the owner's manual.

NOTE 2 Special requirements for seacocks on bilge system discharges are given in ISO 15083.

6.2.1.4 Openings within the boat, such as outboard engine trunks or openings in centreboard casings, shall be considered as possible downflooding openings.

6.2.1.5 For boats to be given design category A or B, downflooding openings not fitted with any form of closing appliance shall only be permitted if they are not in Area I (as defined in ISO 12216) and are essential for cabin or engine ventilation requirements, but these shall at least comply with tightness degree 3.

6.2.1.6 The requirements given in 6.2.2 and 6.2.3 apply to all downflooding openings except:

- a) watertight recesses with a combined volume less than $(L_H B_H F_M)/40$, or quick-draining recesses;
- b) drains from:
 - quick-draining recesses, or
 - watertight recesses which, if filled, would not lead to downflooding or capsize when the boat is upright and which:
 - 1) are freeing ports fitted with non-return flap closures which are watertight from the exterior to degree 3 of ISO 12216, or
 - 2) have a combined cross-sectional area smaller than three times the minimum area required to comply with ISO 11812 for quick-draining cockpits.
- c) non-opening appliances which comply with ISO 12216;
- d) opening appliances located in the topsides which comply with ISO 12216 which are:
 - 1) referenced in the owner's manual as watertight closure to be kept shut when under way, and
 - 2) clearly marked on the inboard side "KEEP SHUT WHEN UNDER WAY" in upper case letters not less than 4,8 mm high, and
 - 3) positioned so that the lowest part of the opening is above the loaded waterline by at least 50 % of the minimum downflooding height required by 6.2.2, or in the case of means of escape fitted to habitable multihulls considered to be vulnerable to inversion (see 7.11 and 7.13) positioned with the bottom of the

clear opening not less than 0,2 m (design category A or B) or 0,1 m (design category C or D) above the loaded waterline when the boat is upright.

- e) opening appliances which are fitted in a compartment of such restricted volume that, even if flooded, the boat satisfies all the requirements;
- f) opening appliances located other than in the topsides which comply with ISO 12216 to tightness degree 2 and which are referenced in the owner’s manual as being “KEEP SHUT WHEN UNDER WAY” and clearly marked as such on the appliance on the inboard side in upper case letters not less than 4,8 mm high.
- g) engine exhausts or other openings that are only connected to watertight systems;
- h) discharge pipes fitted with non-return valves;
- i) openings in the sides of outboard engine wells which are of
 - 1) watertightness degree 2 and having the lowest point of downflooding more than 0,1 m above the loaded waterline, or
 - 2) watertightness degree 3 and having the lowest point of downflooding more than 0,2 m above the loaded waterline and also above the top of the transom in way of the engine mounting, provided that well drain holes are fitted, see Figure 1, or
 - 3) watertightness degree 4 and having the lowest point of downflooding more than 0,2 m above the loaded waterline and also above the top of the transom in way of the engine mounting, provided that well drain holes are fitted, and that the part of the interior or non-quick-draining spaces into which water may be admitted has a length less than $L_H/6$ and from which water up to 0,2 m above the loaded waterline cannot drain into other parts of the interior or non-quick-draining spaces of the boat, see Figure 1.

Dimensions in metres

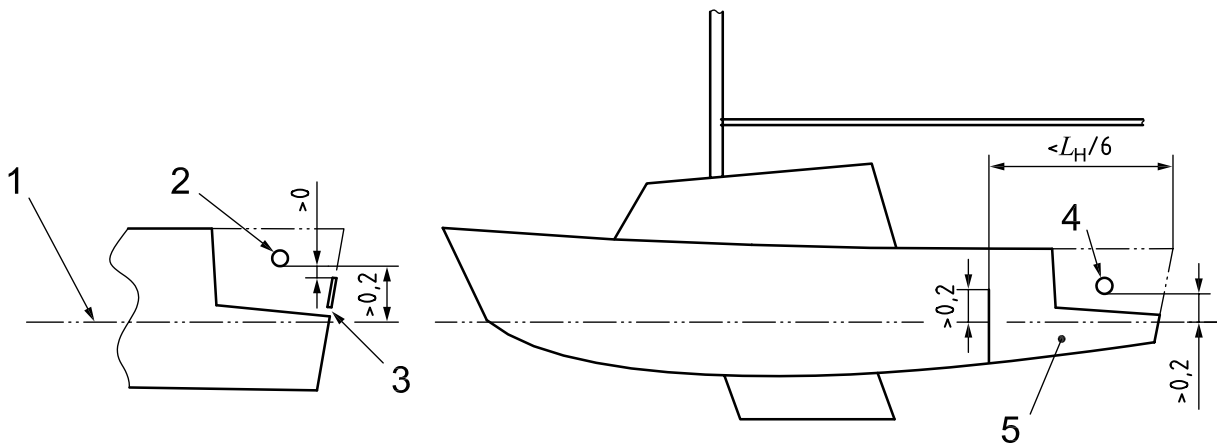

- Key**
- 1 waterline
 - 2 watertightness degree 3 or 4
 - 3 drain
 - 4 watertightness degree 4
 - 5 non-quick-draining space

Figure 1 — Openings in outboard engine wells

6.2.2 Downflooding height

6.2.2.1 Test

This test is to demonstrate sufficient margins of freeboard for the boat in the maximum load condition before water is shipped aboard.

This test shall be performed using people as described below, or test weights to represent people (at 75 kg per person), or by calculation (using a lines plan and displacement derived by a weighing or measured freeboards).

- a) Select a number of people equal to the crew limit, having an average mass of not less than 75 kg.
- b) In calm water, load the boat with all items of maximum load, with the people positioned so as to achieve the design trim.
- c) Measure the height from the waterline to the points at which water could first begin to enter any downflooding opening except those excluded in 6.2.1.6. Where a downflooding opening is fully protected by a higher coaming around the recess from which it leads, the downflooding height shall be measured to the lowest point of that coaming, see Figure B.1. Where an opening in the hull is permanently attached to a watertight pipe or trunk rising to a higher level within the boat, the downflooding height is taken to the critical height within that pipe or trunk.

Downflooding height to downflooding points within quick-draining or watertight recesses shall be measured as though the following openings are closed:

- freeing ports fitted with non-return flap closures which are watertight from the exterior to degree 3 of ISO 12216, or
- drains having a combined cross-sectional area smaller than three times the minimum area required to comply with ISO 11812 for quick-draining cockpits.

6.2.2.2 Requirements

- a) Determine the design category by comparing the measurements with the requirements for minimum downflooding height, as modified by b) and c) below, using either
 - 1) the method of Annex A, which generally gives the lowest requirement, or
 - 2) Figure 2, which is based only on boat length.
- b) Boats assessed using Figure 2 shall be permitted openings having a combined clear area, expressed in square millimetres (mm^2), of not more than $50L_H^2$ within the aft quarter of L_H , provided that the downflooding height to these openings is not less than 75 % of that required by Figure 2.
- c) The required downflooding height for centreboard, drop keel or dagger-board casings on the centreline shall be half of that determined by a) above.

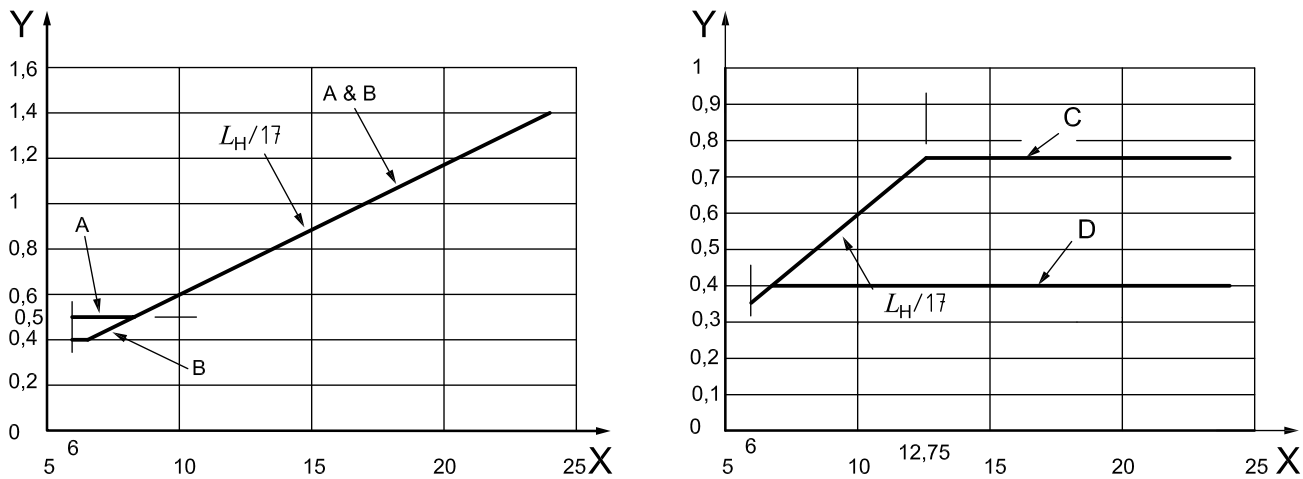

a) Design categories A and B

b) Design categories C and D

Key

- X length of hull (m)
- Y required downflooding height (m)

Figure 2 — Required downflooding height

6.2.3 Downflooding angle

This requirement is to show that there is sufficient margin of heel angle before significant quantities of water can enter the boat.

The downflooding angle to any downflooding opening (ϕ_D) (apart from those excluded by 6.2.1.6), determined using either of the methods in Annex B, shall exceed the required downflooding angle ($\phi_{D(R)}$) as shown in Table 3.

Where a downflooding opening is protected by a higher coaming around the recess from which it opens, the downflooding angle shall be determined to the lowest point of that coaming, see Figure B.1.

Where an opening in the hull is permanently attached to a watertight pipe or trunk rising to a higher level inboard, the downflooding angle is taken to the critical location within that pipe or trunk.

Table 3 — Required minimum downflooding angle

Design category	A and B	C	D
Required downflooding angle, $\phi_{D(R)}$	40°	35°	30°

6.3 Recess size

6.3.1 Application

This requirement is applicable only to:

- boats of design category B assessed using 6.5.2 and having $\phi_N < 90^\circ$, or
- fully enclosed multihulls of design categories A, B or C.

Boats shall be assessed in the loaded arrival condition. The requirements of either 6.3.2 or 6.3.3 apply to recesses except those:

- a) fitted to boats with an angle of vanishing stability greater than 90°, or
- b) where the depth of the recess is less than 3 % of the maximum breadth of the recess over at least 35 % of the periphery, or

EXAMPLE Toe rails, low bulwarks.

- c) formed by a bulwark provided with at least 5 % of its area providing overboard drainage positioned within the lowest 25 % of its height, and where the height of the bulwark is less than 12,5 % of the maximum breadth of the recess, or
- d) where it can be shown that the unobstructed drainage area from the recess on each side of the boat centreline exceeds K multiplied by the volume of the recess to the recess retention level defined in 3.6.11, where K is:
 - 0,09 where the drainage openings are within the lowest 25 % of the recess depth;
 - 0,16 where the drainage openings are within the lowest 50 % of the recess depth;
 - 0,30 where the drainage openings are the full depth of the recess.

To qualify under this paragraph:

- 1) the lower edge of these drainage openings shall be not more than 10 mm above recess sole height for at least 70 % of the width of each opening, and
- 2) where this drainage area is provided by an open or partially open transom, openings shall extend to the outboard sides of the recess sole on both sides.

NOTE The area of drainage openings is expressed in square metres and the volume is expressed in cubic metres.

Recesses completely or partially located within any third of the length must be considered to be swamped simultaneously.

Linked recesses shall be treated as being separate if more than 80 % of the volume of each one cannot drain into an adjacent linked recess. Where two recesses are linked by side decks, the total open cross-sectional area linking the forward and aft recesses must be greater than (open area at transom) × (volume of forward recess) / (volume of all linked recesses).

6.3.2 Simplified methods

6.3.2.1 The percentage loss in initial metacentric height (GM_T) due to free-surface effect when the recess is filled to the retention level defined in 3.6.11 and the boat is in the loaded arrival condition shall be not more than:

- $250 F_R / L_H$ for boats of design category A;
- $550 F_R / L_H$ for boats of design category B;
- $1\,200 F_R / L_H$ for boats of design category C;

where

F_R is the average freeboard to the waterline of the periphery of the recess

$$= (F_A + 2F_S + F_F) / 4$$

F_A is the average of highest and lowest freeboard to the waterline across aft end of recess;

F_S is the average of highest and lowest freeboard to the waterline along the sides of recess;

F_F is the average of highest and lowest freeboard to the waterline across forward end of recess.

Compliance with this requirement may be demonstrated by any of the methods given in 6.3.2.2, 6.3.2.3, or 6.3.2.4 for monohulls, or 6.3.2.2 or 6.3.2.3 for multihulls.

Alternatively the direct calculation method of 6.3.3 may be used.

NOTE Each method given below is increasingly approximate, but in some cases 6.3.2.3 or 6.3.2.4 may be slightly more advantageous than 6.3.2.2.

6.3.2.2 The percentage loss in initial metacentric height (GM_T) due to free-surface effect may be calculated from:

$$\% \text{ loss } GM_T = \frac{102\,500 \times SMA_{RECESS}}{m_{LA} \times GM_T} \quad (1)$$

where

SMA_{RECESS} is the second moment of area of free-surface of recess at retention height as defined in 3.6.11, about the longitudinal axis through the centre of area, expressed in m^4 .

Where multiple recesses have to be considered swamped simultaneously, SMA_{RECESS} should include all such recesses.

6.3.2.3 The percentage loss in initial metacentric height (GM_T) due to free-surface effect may be estimated from:

$$\% \text{ loss } GM_T = \left(\frac{220 \times SMA_{RECESS}}{SMA_{WP}} \right) \quad (2)$$

where

SMA_{RECESS} is the second moment of area of free-surface of recess at retention height as defined in 3.6.11, about the longitudinal axis through the centre of area, expressed in m^4 ;

SMA_{WP} is the second moment of area of waterplane of boat at m_{LA} .

Both second moments of area are about the longitudinal axis through the respective centre of area, expressed in m^4 .

Where multiple recesses have to be considered swamped simultaneously, SMA_{RECESS} should include all such recesses.

6.3.2.4 The percentage loss in initial metacentric height (GM_T) due to free-surface effect may alternatively be estimated more approximately, and therefore more conservatively, from:

$$\% \text{ loss } GM_T = 240 \left(\frac{l \times b^3}{L_H \times B_H^3} \right)^{0,7} \quad (3)$$

where

l is the maximum length of recess at the retention level as defined in 3.6.11, expressed in metres;

b is the maximum breadth of recess at the retention level as defined in 3.6.11, expressed in metres.

Where multiple recesses have to be considered swamped simultaneously, l shall be the sum of the length of individual recesses and b shall be the maximum value of any recesses considered swamped at the same time.

NOTE This method is not appropriate for multihull boats.

6.3.3 Direct calculation method

- a) Calculate the righting moment curve (N·m) for the boat in the loaded arrival condition in calm water using computer modelling which correctly represents (in calm water) the roll, heave and pitch of the boat, and with water in the recess allowed to flow in or out over gunwales or coamings according to the attitude of the boat in calm water, assuming that no flow through drains occurs. When the boat is upright, the recess shall be assumed to be filled to the following percentage of the capacity at the recess retention level:

$$(60 - 240 F/L_H) \% \quad (4)$$

where

F is the minimum freeboard to the waterline of the coaming of the recess in question.

- b) In the range from the steady equilibrium heel angle to the least of the downflooding angle, ϕ_{DA} , the angle of vanishing stability, ϕ_V , and 90° , the righting moment (N·m) shall attain a value of at least:

- $3,6m_{LA}$ for design category A;
- $2,6m_{LA}$ for design category B;
- $2,1m_{LA}$ for design category C;

where

m_{LA} is the mass of the boat in the loaded arrival condition without any swamp water;

ϕ_{DA} is the angle of heel at which openings (except those listed in 6.2.1.6) not marked "KEEP SHUT WHEN UNDER WAY" and having a total combined area, expressed in square centimetres (cm^2), greater than the number represented by $1,2L_H B_H F_M$, first become immersed.

6.4 Minimum righting energy

Boats to be assigned to design category A or B shall comply with the requirements given in Table 4.

Table 4 — Required minimum righting energy

Design category	Required minimum righting energy kg·m·deg
A	$m_{MO} \times A_{GZ} > 172\,000$
B	$m_{MO} \times A_{GZ} > 57\,000$
where A_{GZ} is the positive area under the righting lever curve in the minimum operating condition, expressed in metre degrees from upright to ϕ_V .	

6.5 Angle of vanishing stability

These requirements are intended to ensure an absolute minimum survival capability in severe conditions.

The angle of vanishing stability for the boat in minimum operating condition and loaded arrival condition shall be obtained using Annex C.

Boats shall normally comply with 6.5.1, but those of design category B may alternatively comply with 6.5.2.

6.5.1 Normal requirement

All boats using options 1 or 2 in Table 2 shall comply with Table 5.

Table 5 — Required minimum angle of vanishing stability

Design category	Required minimum angle of vanishing stability, $\phi_{V(R)}$
A	$\phi_{V(R)} = (130 - 0,002m)$ but always $\geq 100^\circ$
B	$\phi_{V(R)} = (130 - 0,005m)$ but always $\geq 95^\circ$
C	$\phi_{V(R)} = 90^\circ$
D	$\phi_{V(R)} = 75^\circ$

6.5.2 Alternative requirement for design category B

As an alternative to 6.5.1, boats may be assigned to design category B provided that:

- a) $\phi_{V(R)} = (130 - 0,005m)$ but always $\geq 75^\circ$;
- b) it has been shown by calculation using Annex D that when the swamped or inverted boat is totally immersed, the volume of buoyancy, expressed in cubic metres (m^3) available from the hull structure, fittings and flotation elements is greater than the number represented by $(m_{LDC}/850)$, thus ensuring that it is sufficient to support the mass of the loaded boat by a margin. Allowance for trapped air (apart from dedicated air tanks and watertight compartments) shall not be included;
- c) where non-habitable compartments accessible via hatches or doors are used to demonstrate positive flotation after capsize, such compartments shall be constructed to watertightness degree 1 (see ISO 11812), with hatches and doors satisfying the watertightness requirements for degree 2 of ISO 12216;
- d) closures to access openings into such watertight compartments shall be clearly marked on both sides in upper case letters not less than 4,8 mm high "KEEP SHUT WHEN UNDER WAY";
- e) where flotation elements are used, the requirements of Annex E are satisfied;
- f) stability information similar to that required by 7.5 is provided, except that instead of being derived from Annex G, the recommended maximum wind speed for a given sail area shall be determined on the basis that the upright wind heeling moment in a gust of twice the mean wind pressure shall not be greater than the maximum righting moment;
- g) the safety signs shown in Figure 3 are displayed at the main control position. The signs shall comply with Clause 8;
- h) the wind speed shown in Figure 3 b) shall correspond to the apparent wind speed at which the standard sail plan is required to be reefed in accordance with the information required by 7.5 b). It may be given in either knots or metres per second.

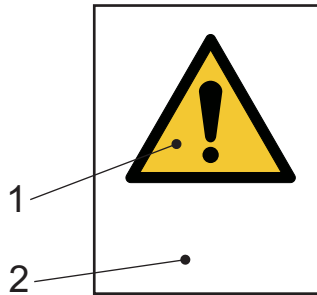
**Key**

- 1 sign W001 “General warning” from ISO 7010
- 2 supplementary text to read “Risk of capsize!”

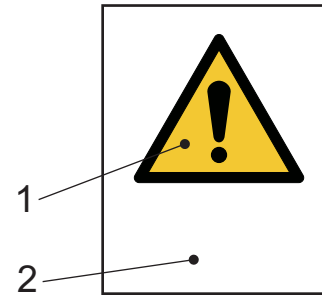
a) Capsize warning**Key**

- 1 sign W001 “General warning” from ISO 7010
- 2 supplementary text to read “Reef sails at N knots (or m/s) apparent wind speed, where N is the relevant wind speed

b) Reef sails**Figure 3 — Safety signs****6.6 Stability index (STIX)****6.6.1 Method**

The stability index is a method of obtaining an assessment of the ability of a monohull boat to resist, and to recover from, a knockdown or inversion. The index consists of a length factor which may be modified by seven factors which address separate aspects of the stability and buoyancy properties.

Each individual factor shall be calculated as given in 6.6.2 to 6.6.8, using the values for each parameter relating to the appropriate loading condition, and the value of STIX and the associated design category shall then be determined according to 6.6.9.

Each modifying factor can be obtained in any of three ways:

- a) the minimum permitted value, without further calculation;
- b) using approximate methods;
- c) from rigorous calculation.

It should be noted that the value of each factor is subject to both upper and lower limits.

All righting lever and downflooding properties are for the boat in the appropriate loading condition, amended as necessary for boats fitted with provision for asymmetric ballasting. The most advantageous categorization is obtained if these properties are calculated rigorously. The downflooding angle can either be obtained from Annex B (which provides an approximate method of calculation), or the lower limit for a given factor in STIX may be adopted. Any combination of rigorous and approximate calculations, or lower limits, is permissible.

6.6.2 Dynamic stability factor (FDS)

This factor represents the inherent righting energy (relative to its length) to be overcome before a stability incident occurs.

$$FDS = \left(\frac{A_{GZ}}{15,81\sqrt{L_H}} \right)^{0,3} \tag{5}$$

where

A_{GZ} is the positive area under the righting lever curve from upright up to ϕ_V , expressed in metre degrees, for the appropriate loading condition;

but FDS shall never be taken as less than 0,5 or greater than 1,5.

6.6.3 Inversion recovery factor (FIR)

This factor represents the ability to recover unaided after an inversion.

$$FIR = \phi \sqrt{(125 - m/1\ 600)} \quad \text{if } m < 40\ 000 \tag{6}$$

$$= \phi \sqrt{100} \quad \text{if } m \geq 40\ 000 \tag{7}$$

where

m is the mass of the boat (refer to 6.1.3), expressed in kilograms;

but FIR shall never be taken as less than 0,4 or greater than 1,5.

6.6.4 Knockdown recovery factor (FKR)

This factor represents the ability of a boat to spill water out of the sails and hence recover after being knocked down.

Calculate

$$F_R = GZ_{90}m/(2A_S h_{CE}) \tag{8}$$

where

m is the mass of the boat (see 6.1.3), expressed in kilograms;

GZ_{90} is the righting lever at 90° heel, expressed in metres, for the boat with a mass of m ;

h_{CE} is the height of centre of the nominal sail area (A_S) above the waterline, when the boat is upright, expressed in metres, for the boat with a mass of m .

If $F_R \geq 1,5$ $FKR = 0,875 + 0,083\ 3F_R$

If $F_R < 1,5$ $FKR = 0,5 + 0,333F_R$

If $\phi_V < 90^\circ$ $FKR = 0,5$

but FKR shall never be taken as less than 0,5 or greater than 1,5.

6.6.5 Displacement-length factor (FDL)

This factor accounts for the favourable effect of heavier displacement on a given length increasing the resistance to capsize.

$$FDL = \left\{ 0,6 + \left[\frac{15mF_L}{L_{BS}^3 (333 - 8L_{BS})} \right] \right\}^{0,5} \quad (9)$$

where

$$L_{BS} = (2L_{WL} + L_H)/3 \quad (10)$$

$$F_L = (L_{BS}/11)^{0,2} \quad (11)$$

m is the mass of the boat (refer to 6.1.3), expressed in kilograms;

but FDL shall never be taken as less than 0,75 or greater than 1,25.

6.6.6 Beam-displacement factor (FBD)

This factor accounts for the increased vulnerability to capsize in beam seas of boats with appreciable topside flare, and increased beam in relation to displacement.

Calculate

$$F_B = 3,3B_H/(0,03m)^{1/3} \quad (12)$$

where

m is the mass of the boat (refer to 6.1.3), expressed in kilograms.

$$\text{If } F_B > 2,20 \quad FBD = [13,31B_{WL}/(B_H F_B^3)]^{0,5} \quad (13)$$

$$\text{If } F_B < 1,45 \quad FBD = [B_{WL} F_B^2 / (1,682 B_H)]^{0,5} \quad (14)$$

$$\text{otherwise } FBD = 1,118(B_{WL}/B_H)^{0,5} \quad (15)$$

but FBD shall never be taken as less than 0,75 or greater than 1,25.

6.6.7 Wind moment factor (FWM)

For boats where either ϕ_D or ϕ_{DH} is less than 90° , this factor represents the risk of downflooding due to a gust of wind heeling an unreefed boat.

$$\text{If } \phi_{DW} \geq 90^\circ \quad FWM = 1 \quad (16)$$

$$\text{If } \phi_{DW} < 90^\circ \quad FWM = v_{AW}/17 \quad (17)$$

where

ϕ_{DW} is ϕ_{DC} or ϕ_{DH} , whichever is less;

v_{AW} is the steady apparent wind speed, expressed in metres per second (m/s), required to heel the boat to ϕ_{DW} when carrying full sail plan (i.e. without reefing);

$$v_{AW} = \left\{ \frac{13mGZ_D}{\left[A_S (h_{CE} + h_{LP}) |\cos \phi_{DW}|^{1,3} \right]} \right\}^{0,5} \quad (18)$$

where

GZ_D is the righting lever when heel angle = ϕ_D , in metres;

$h_{CE} + h_{LP}$ is the height, expressed in metres, between the geometric centres of the above-water and below-water profiles of the boat, including sails, masts and hull, with centreboards, daggerboards and leeboards in the lowered position, when the boat is upright;

m is the mass of the boat (refer to 6.1.3), expressed in kilograms;

but FWM shall never be taken as less than 0,5 or greater than 1,0.

6.6.8 Downflooding factor (FDF)

This factor represents the risk of downflooding in a knockdown.

$$FDF = \phi_{DF}/90 \tag{19}$$

where

ϕ_{DF} shall be taken as the least of the following: ϕ_{DC} , ϕ_{DH} , ϕ_{DA} and ϕ_V (refer to 3.3.2);

but FDF shall never be taken as less than 0,5 or more than 1,25.

If a boat has a reserve of buoyancy in accordance with 6.5.2 b), and also has $GZ_{90} > 0$ when the boat is fully flooded with water, then FDF calculated as above shall be increased by 20 %.

6.6.9 Calculation of the stability index (STIX)

The stability index (STIX) is determined from:

$$STIX = (7 + 2,25L_{BS})(FDS \times FIR \times FKR \times FDL \times FBD \times FWM \times FDF)^{0,5} \tag{20}$$

where

$L_{BS} = (2L_{WL} + L_H)/3$, expressed in metres.

STIX shall be greater than the required value for the design category ($STIX_{(R)}$), as given in Table 6.

Table 6 — Requirements for STIX

Design category	A	B	C	D
STIX shall be greater than $STIX_{(R)}$ =	32	23	14	5

6.7 Knockdown-recovery test

6.7.1 This test is to demonstrate that a boat can return to the upright unaided after being knocked down. Compliance may be demonstrated either by a physical test, or by calculation according to 6.7.5.

6.7.2 This test shall be conducted in calm water, with the boat in the light craft condition with the addition of persons, loose water or another test weight to a total mass not less than that of the crew limit. The sails shall be lowered and stowed, and centreboard(s) or keel(s) raised unless they can be fixed in the lowered position and an appropriate instruction is given in the owner’s manual. If persons are used, they shall be positioned as shown in Figure 4 prior to release of the mast. If water or another weight is used, it shall be placed inside the hull. Water shall not be used if it would not be retained when the boat is heeled as required by 6.7.3 or 6.7.4.

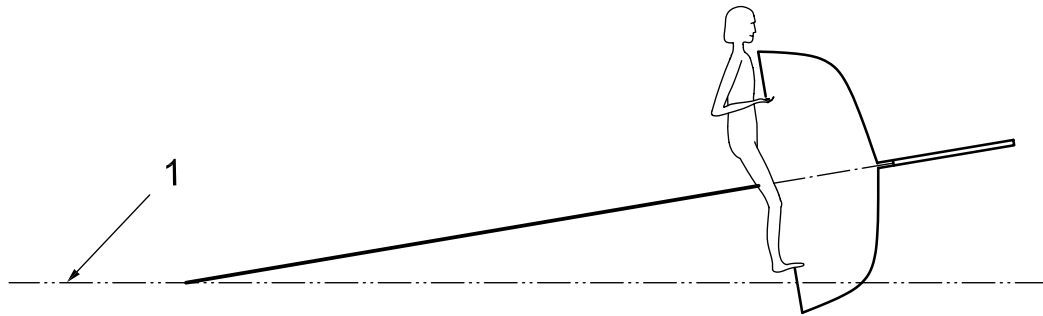
**Key**

1 waterline

Figure 4 — Positioning of the crew (design category C test illustrated)

6.7.3 For design category C, the boat shall be quickly rotated until the masthead touches the water surface and shall then be released after 60 s. The boat may begin to flood, but this is acceptable provided the boat rapidly returns to a nearly upright position, and provided that the boat does not sink and that the residual freeboard would enable the boat to be pumped or bailed out. The longitudinal position of the crew may be optimized to ensure sufficient residual freeboard for pumping or bailing.

6.7.4 For design category D, the boat shall be quickly rotated until the mast is horizontal and shall then be released after 10 s. The boat may begin to flood, but this is acceptable provided the boat rapidly returns to a nearly upright position, and provided the boat does not sink and that the residual freeboard would enable the boat to be pumped or bailed out. The longitudinal position of the crew may be optimized to ensure sufficient residual freeboard for pumping or bailing.

6.7.5 Calculation to show that the righting moment is positive at the initial angle of heel may be used instead of a practical test, provided it is assumed that the main access hatchway to cabins is fully open, and that water enters any spaces subject to downflooding.

6.7.6 If the downflooding characteristics are not the same port and starboard, the test shall be conducted in the most critical direction. When this is unclear, it shall be conducted in both directions.

6.8 Wind stiffness test**6.8.1 General**

This test is to demonstrate that, when a sailing boat is heeled to a steady wind speed appropriate to the design category, the boat does not start flooding.

Compliance may be demonstrated either by practical test (see 6.8.2), or by calculation (see 6.8.3).

6.8.2 Practical test

6.8.2.1 With the boat in the light craft condition, place a person or weights with a mass of 75 kg on the centreline on the cockpit sole to represent one crew situated within reach of the helm. Sails shall be stowed ready for hoisting, and centreboard(s) or keel(s) raised unless they can be fixed in the lowered position and an appropriate instruction is given in the owner's manual.

6.8.2.2 Apply a heeling couple to the boat, for example using either of the arrangements shown in Figure 5 and taking care to keep the two lines parallel, until the first of the following occurs:

— the boat begins to fill with water; or

- the load T and the corresponding heel angle meet those for the desired wind speed; or
- the boat reaches 45° heel.

NOTE 1 For the purposes of this test, the mast may be fitted with temporary reinforcing or staying. The use of twin underwater restraint lines located forward and abaft the mast will minimize any tendency of the boat to yaw.

NOTE 2 Figure 5 shows two alternative ways of arranging the lines. Tension T_1 should be used in conjunction with lever h_1 and T_2 should be used in conjunction with lever h_2 .

6.8.2.3 Determine the lever height h , in metres, the tension T , in kilograms, and the heel angle ϕ_T , in degrees.

6.8.2.4 Calculate the steady wind speed, in metres per second, needed to produce this heel angle as follows:

$$\text{Calculated wind speed (m/s)} = \sqrt{\frac{13hT + 390B_H}{A'_S (h'_{CE} + h_{LP})(\cos\phi_T)^{1,3}}} \tag{21}$$

where

- A'_S is the standard sail area, as defined in 3.4.9, expressed in square metres;
- h'_{CE} is the height of the geometrical centre of A'_S above the waterline when upright, expressed in metres;
- h_{LP} is the height of the waterline above the geometrical centre of the lateral profile area of the immersed hull and keel(s)/centreboard(s) and rudder(s), when upright, expressed in metres.

NOTE h'_{CE} and h_{LP} are illustrated in Figure 6.

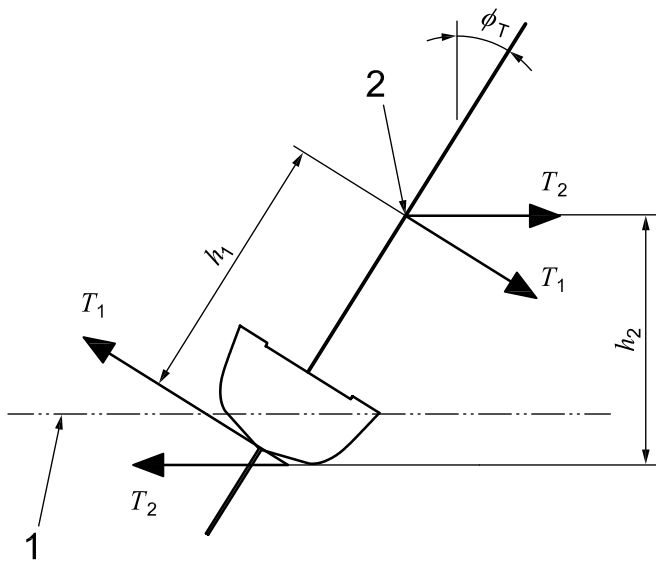

Key
 1 waterline
 2 any convenient location

Figure 5 — Wind stiffness test

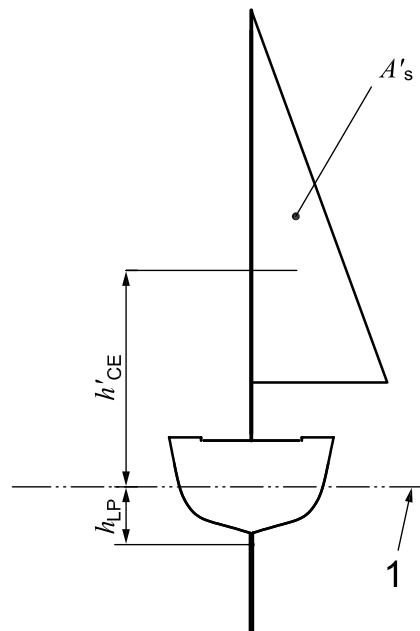

Key
 1 waterline

Figure 6 — Dimensions h'_{CE} and h_{LP}

6.8.3 Compliance by calculation

6.8.3.1 Calculate the curve of righting moments of the hull (in newton metres) when loaded with one crew member of 75 kg on the centreline.

6.8.3.2 To allow for one crew seated to windward, increase this curve by $294B_H\cos\phi$, (N·m).

6.8.3.3 Calculate the wind heeling moment curve for the minimum wind speed for the intended design category given in Table 7, from:

$$0,75 v_W^2 A'_S (h'_{CE} + h_{LP}) (\cos\phi)^{1,3} \text{ (N·m)} \quad (22)$$

where

v_W is the wind speed, expressed in metres per second.

6.8.3.4 The boat complies if the curves intersect at a heel angle of less than the downflooding angle or 45° if this is less. To achieve compliance, a reefed sail plan may be assumed, see 6.8.4.2.

6.8.3.5 All the requirements of 6.8.4 shall be satisfied.

6.8.4 Requirements

6.8.4.1 The boat shall be given design category C or D according to whether the calculated wind speed exceeds the requirements given in Table 7.

Table 7 — Required calculated wind speed

Wind speed in metres per second

Design category	C	D
Option 5	13	8
Option 6	11	6

6.8.4.2 If the boat is unable to satisfy the requirements of Table 7 with full sail, it may be given category C or D if these requirements are satisfied when reefed provided that the reefed sail area is not less than two-thirds of A'_S as defined in 3.4.9.

6.8.4.3 The owner's manual shall clearly state the apparent wind speed at which reefing becomes necessary (given in either knots or metres per second), and the possible consequences of failing to reef at the appropriate time. The wind speed given shall correspond to that at which the standard sail area as defined in 3.4.9 is required to be reefed in accordance with 6.8.2 or 6.8.3 above.

NOTE The consequences of failing to reef at the appropriate time may be expressed in terms similar to the following:

IMPORTANT — If not sailed with care, this boat may swamp or capsize unless the sail area is adjusted to suit the prevailing wind conditions and the main sheet is not belayed.

6.8.4.4 All boats assessed using this test shall prominently display at the main control position one of the safety signs given in Figure 7. Safety signs shall comply with Clause 8.

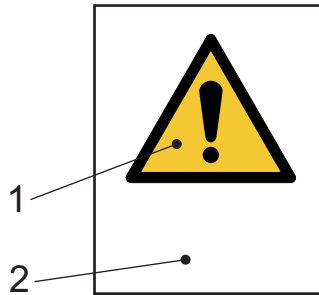

Key

- 1 sign W001 “General warning” from ISO 7010
- 2 supplementary text to read “Reef sails at *N* knots (or m/s) apparent wind speed”, where *N* is the relevant wind speed

a) Fully enclosed boats

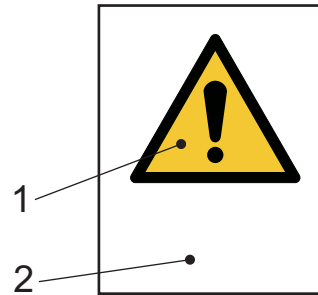

Key

- 1 sign W001 “General warning” from ISO 7010
- 2 supplementary text to read “Reef sails before water enters, or boat will flood and may not recover”

b) Other boats

Figure 7 — Reefing safety signs

6.8.4.5 In Figure 7 a) the wind speed given shall be obtained using 6.8.4.3.

6.9 Flotation requirements

6.9.1 Because some sailing boats may be capsized if incorrectly handled, it shall be shown that, when the boat is inverted and/or fully flooded, either

- a) the volume of buoyancy, expressed in cubic metres, in the hull, fittings and equipment is greater than the number represented by $(m_{LDC}/850)$, using the method of Annex D, thus ensuring that it is sufficient to support the mass of the loaded boat by a margin. Habitable parts of the boat may not be included. Dedicated air tanks and watertight compartments not containing habitable parts of the boat may be included. Apart from these, allowance for trapped bubbles of air shall not be included, alternatively;
- b) the boat when loaded to m_{LDC} does not sink, as demonstrated by a physical test.

6.9.2 Where non-habitable compartments accessible via watertight hatches or doors are used to demonstrate positive flotation after capsize or swamping, the compartment shall be constructed to watertightness degree 1 (see ISO 11812), with access closures satisfying the watertightness requirements for degree 2 of ISO 12216.

Closures to access openings into watertight compartments shall be clearly marked on both sides in upper case letters not less than 4,8 mm high:

“KEEP SHUT WHEN UNDER WAY”

NOTE “Under way” has the meaning “not at anchor, or made fast to the shore, or aground”

Where flotation elements are used, the requirements of Annex E apply.

6.10 Capsize-recovery test

6.10.1 This test is to demonstrate that a capsized boat can be returned to the upright by the actions of the crew using their body action and/or righting devices purposely designed and permanently fitted to the boat, that it will subsequently float, and to verify that the recommended minimum crew mass is sufficient for the recovery method used.

6.10.2 Flotation material and elements used in boats employing this test shall comply with Annex E.

6.10.3 The test shall be conducted in calm conditions, with the boat in the light craft condition with loose equipment in the normal operating location, and air tanks, containers or bags having been tested in accordance with Annex E.

6.10.4 Fore-and-aft sails shall be hoisted and set.

6.10.5 Centreboard(s) or keel(s) shall be lowered.

6.10.6 The boat shall be capsized to approximately 180° or the maximum practicably attainable equilibrium heel angle, with the crew in the water alongside. Sufficient depth of water shall be available to allow unimpeded movement of the boat. The boat shall not sink after floating in this manner for 5 min.

6.10.7 The number and combined mass of the crew shall be the minimum suitable for the boat as recommended by the builder.

6.10.8 The boat shall be righted by the crew without exploiting the sea bed or any external aid. No more than three attempts are permissible, each of which shall be limited to 5 min duration from commencement. Only one successful attempt is required.

6.10.9 The following information shall be recorded for inclusion in the owner's manual:

- the likelihood of capsize when in normal use;
- the righting technique which is most successful;
- the minimum necessary crew mass, expressed in kilograms.

NOTE The likelihood of capsize may be expressed in terms similar to the following:

- "This boat is very tolerant and if handled sensibly is most unlikely to capsize except in severe conditions."; or
- "If sailed with care, this boat is unlikely to capsize in normal use provided the sail area is adjusted to suit the prevailing conditions and the main sheet is not belayed."; or
- "Even if sailed with great care and skill, the design of this boat is such that capsize is always a possibility, even in light conditions."

6.10.10 After the boat has been righted and one person with a mass of not less than 75 kg has reboarded, the boat shall float such that the residual freeboard will enable the boat to be pumped or bailed out. The longitudinal position of that person may be optimized to ensure sufficient residual freeboard for pumping or bailing.

6.10.11 Without bailing the boat at all, after the remainder of the crew up to the crew limit have reboarded, the boat shall float approximately level with not more than one-third of the deck or gunwale submerged, for not less than 5 min.

6.10.12 Boats passing the above test shall be given either design category C or D at the discretion of the builder, and shall be permanently marked in a prominent position with one of the safety signs shown in Figure 8, and appropriate text added in the owner's manual – see Annex F. Safety signs shall comply with Clause 8.

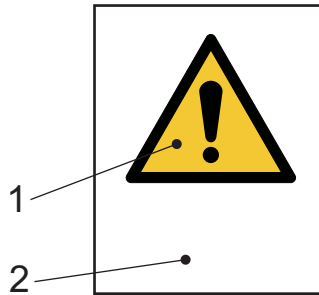

Key

- 1 Sign W001 "General warning" from ISO 7010
- 2 Supplementary text to read "Risk of capsize!"

a) Where there is no cabin

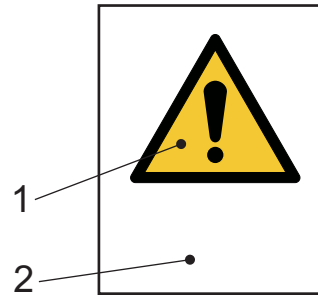

Key

- 1 Sign W001 "General warning" from ISO 7010
- 2 Supplementary text to read "Risk of capsize! Persons in cabin may be trapped!"

b) Where boat is fitted with a cabin

Figure 8 — Safety signs for capsize recoverable boats

6.11 Detection and removal of water

6.11.1 The internal arrangement of a boat shall facilitate the drainage of water, either:

- to bilge suction point(s),
- to a location from which it may be bailed rapidly, or
- directly overboard.

6.11.2 Boats shall be provided with means of removing water from the bilges in accordance with ISO 15083. The bilge pumping capacity (l/min) should reflect the degree of decking and consequent risk of water entering the boat.

6.11.3 Design category C boats using options 3, 5 or 7 shall be provided with means of detecting the presence of water in the bilge from the helm position, which shall comprise:

- direct visual inspection, or
- transparent inspection panels in interior mouldings, or
- bilge alarms, or
- indication of the operation of automatic bilge pumps, or
- other equivalent means.

NOTE Essential Requirement 3.5 of EU Directive 94/25/EC requires that all craft be designed so as to minimize the risk of sinking, and that particular attention be paid where appropriate to:

- cockpits and wells, which should be self-draining or have other means of keeping water out of the boat interior,
- ventilation fittings,
- removal of water by pumps or other means.

7 Requirements for catamarans, trimarans and form-stable monohulls

7.1 Requirements to be applied

7.1.1 Where catamarans and trimarans have $L_H > 5B_{CB}$, they shall comply with the requirements of Clause 6. All other catamarans and trimarans shall comply with either

- a) 7.2 to 7.13, or
- b) the capsize-recovery test as described in 6.10, when the boat shall be assigned either design category C or D at the discretion of the builder.

NOTE For any given test, the requirements may vary according to the chosen option, e.g. for downflooding height.

7.1.2 All boats of design category A and B shall be fully enclosed, as defined in 3.1.8.

7.1.3 Monohulls applying 6.5.2 (form-stable monohulls) are required to comply with some requirements of Clause 7 – see 6.5.2.

7.2 Downflooding openings

The requirements of 6.2.1 apply.

7.3 Downflooding height

The requirements of 6.2.2 apply.

7.4 Recess size

The requirements of 6.3 apply to fully enclosed boats of design categories A, B and C.

7.5 Stability information

Since sailing multihull boats and form-stable monohulls may capsize, information as listed in a) to d) below shall be:

- displayed in a durable manner inside the boat close to the main companionway or navigation station, and
- provided in the owner's manual (see Annex F).

NOTE "A durable manner" means a rigid plate or flexible label affixed to the craft in such a way that it can only be removed by the use of tools.

- a) The stability hazards to which these boats are vulnerable, including the risk of capsize in roll and/or pitch, particularly in breaking seas.
- b) The apparent (i.e. relative) wind speed (expressed in knots or metres per second) at which the area of any practical combination of sails should be reduced when sailing in calm water in the minimum operating condition, taking account of the hazardous effects of gusts. Additional information relevant to the maximum load condition can also be provided if desired.

This information can be calculated using Annex G (which includes a margin for gusts), or alternatively be derived from sailing trials. The method of determination shall be stated.

NOTE For form-stable monohulls, refer to 6.5.2 e).

If derived from sailing trials, the wind strength quoted in the owner's manual shall correspond to a wind speed of not greater than 70 % of that required to

- 1) lift the windward hull of catamarans out of the water, or

- 2) lift the main hull of trimarans out of the water, or submerge the leeward sidehull, whichever occurs sooner, or
- 3) for form-stable monohulls, heel the boat to the angle at which the righting moment is maximum.

The safe wind speed information should permit safe sailing when the boat is on autopilot and when crew members may not be close to the sail controls.

The maximum safe wind speed with full sail may also be restricted by the strength of the rig, rig attachments and sails. Where this is so, the information provided for the owner shall be based on the lower of the stability and the strength limitations.

- c) The choice of sails to be set with respect to the prevailing wind strength, relative wind direction, and sea state.
- d) Precautions to be taken when altering course from a following to a beam wind.

7.6 Safety signs

The safety sign shown in Figure 9 shall be permanently displayed at the main control position. The sign shown in Figure 10 is also required if the boat is considered to be vulnerable to inversion when used in its design category as determined in accordance with 7.7. Both signs shall comply with Clause 8.

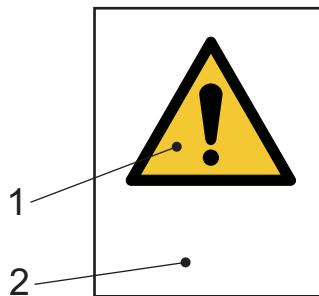

- Key**
- 1 sign W001 “General warning” from ISO 7010
 - 2 supplementary text to read “Reef sails at *N* knots (or m/s) apparent wind speed”, where *N* is the relevant wind speed

a) Fully enclosed boats

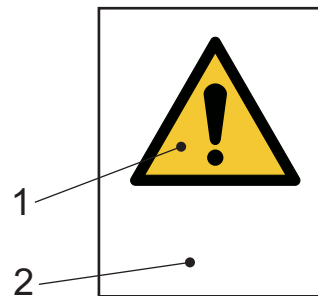

- Key**
- 1 sign W001 “General warning” from ISO 7010
 - 2 supplementary text to read “Reef sails before water enters, or boat will flood and may not recover”

b) Other boats

Figure 9 — Reefing safety signs

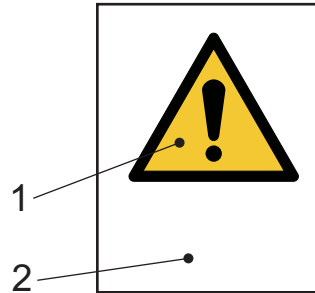
**Key**

- 1 sign W001 “General warning” from ISO 7010
- 2 supplementary text to read “Risk of capsize”

Figure 10 — Capsize warning sign

The wind speed shown in Figure 9 a) shall correspond to the apparent wind speed at which the standard sail area is required to be reefed in accordance with the information required by 7.5 b). It may be given in either knots or metres per second.

NOTE Standard sail area is defined in 3.4.9.

7.7 Bare poles factor

The bare poles factor (BPF), for subsequent use in 7.8 and 7.9, shall be calculated for the boat in the minimum operating condition as follows:

- a) Calculate the theoretical wind speed in knots for the boat using the method of G.1.2 and G.1.4 for the case when all the sails are stowed (v_{BP}). The lesser figure for transverse and longitudinal stability shall be used below.
- b) Calculate BPF as follows:

$$BPF = \left(\frac{v_{BP}}{70} \right)^{0,4} \quad \text{where } v_{BP} < 70 \quad (23)$$

$$BPF = 1,0 \quad \text{where } v_{BP} \geq 70 \quad (24)$$

NOTE The BPF provides a means of varying the minimum requirements for each design category as a function of the windage of the basic rig.

7.8 Rolling in breaking waves

To provide a degree of protection against being rolled over by breaking waves, the maximum transverse righting lever (m) for the boat in the minimum operating condition shall exceed the values given in Table 8.

NOTE The maximum transverse righting lever may be calculated using the method of Annex C or using G.2.1.

Table 8 — Minimum requirements for maximum transverse righting lever

Righting lever in metres

Design category	Catamarans	Trimarans
A	1,85/BPF	2,9/BPF
B	1,3/BPF	2,2/BPF
C	0,7/BPF	1,5/BPF

7.9 Pitchpoling

To provide a degree of protection against being pitchpoled over the bow by breaking waves, the longitudinal righting moment area (kilonewton metre radians) for the boat in the minimum operating condition shall exceed the values given in Table 9.

The longitudinal righting moment area (kilonewton metre radians) shall be calculated from design trim to a bow down trim angle of 20° or immersion of the weather deck at the stem (main hull for trimarans), whichever occurs earlier. Any of the methods given in Annex H may be used for catamarans, but only H.3 or H.4 may be used for trimarans.

NOTE 1 “Bow down trim” describes the trim where the bow is being depressed compared to the design trim.

NOTE 2 The weather deck at the stem comprises a watertight deck, excluding any bulwarks or raised stem post.

Table 9 — Requirements for minimum longitudinal righting moment area

In kilonewton metre radians

Design category	Minimum longitudinal righting moment area
A	20/BPF
B	7/BPF
C	2/BPF

7.10 Diagonal stability

The boat shall be assessed in the minimum operating condition in both the following trim conditions:

- at the limiting bow down trim angle (see G.2.2), and
- at a stern down trim angle equal in magnitude to the limiting bow down trim angle.

In these trimmed conditions, the transverse righting moment for 1° heel shall be greater than:

- for design category A: 5 000 (N·m) or $1,1m_{MO}$ (N·m) whichever is greater, and
- for design category B: 1 500 (N·m).

NOTE 1 Refer to Annex H for methods of calculation.

NOTE 2 “Bow down trim” describes the trim where the bow is being depressed compared to the design trim. Similarly, “stern down trim” describes the trim where the stern is being depressed compared to the design trim.

7.11 Habitable multihull boats

7.11.1 Habitable boats as defined in 3.1.9, if considered to be vulnerable to inversion when used in their design category according to 7.11.2 or 7.11.3, shall comply with:

- the requirements for inverted buoyancy given in 7.12, and
- the requirements for means of escape given in 7.13.

7.11.2 A catamaran sailing boat is considered to be vulnerable to inversion if any of the following apply:

- the maximum transverse righting lever for the boat in the minimum operating condition is less than 135 % of the minimum requirement for the design category according to 7.8 (the maximum transverse righting lever shall be calculated using the method of Annex C or using G.2.1); or
- the longitudinal righting moment area for the boat in the minimum operating condition is less than 135 % of the minimum requirement for the design category according to 7.9 (the longitudinal righting moment area shall be calculated using Annex H); or

- c) the wind speed at which the standard sail area is required to be reefed according to calculations performed in accordance with Annex G is less than
- 25 kn for design category A,
 - 22 kn for design category B,
 - 19 kn for design category C,
 - 16 kn for design category D.

7.11.3 A trimaran sailing boat is considered to be vulnerable to inversion if any of the following apply:

- a) the maximum transverse righting lever for the boat in the minimum operating condition is less than 180 % of the minimum requirement for the design category according to 7.8 (the maximum transverse righting lever shall be calculated using the method of Annex C or using G.2.1); or
- b) the longitudinal righting moment area for the boat in the minimum operating condition is less than 180 % of the minimum requirement for the design category according to 7.9 (the longitudinal righting moment area may be calculated using H.3 or H.4, but not H.2); or
- c) for the boat in the minimum operating condition, the wind speed at which the standard sail area is required to be reefed according to calculations performed in accordance with Annex G is less than
- 25 kn for design category A,
 - 22 kn for design category B,
 - 19 kn for design category C,
 - 16 kn for design category D;

or

- d) if $B_{CB} < 14\text{m}$ (category A) or $< 8\text{m}$ (category B), the volume of one sidehull calculated in accordance with Figure 11 is less than 130 % of the displaced volume in the maximum load condition.

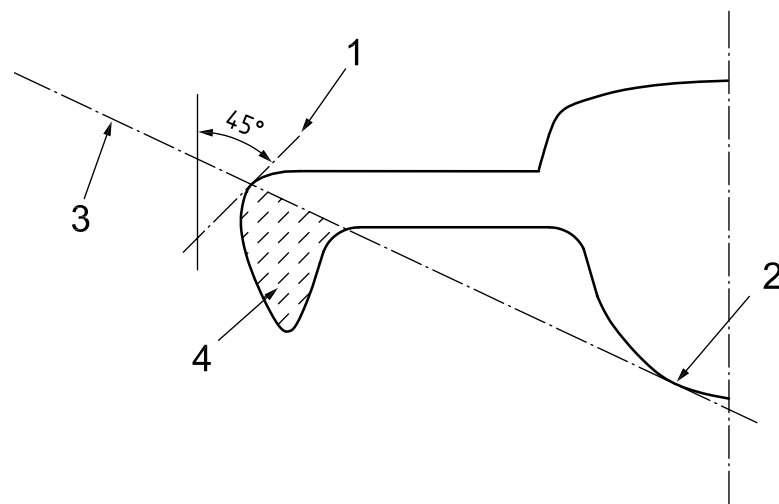

Key

- 1 45° tangent at mid waterline length position
- 2 tangent to hull at mid waterline length position
- 3 plane parallel longitudinally with design trim waterline
- 4 sidehull volume

Figure 11 — Definition of sidehull volume

7.12 Buoyancy when inverted

7.12.1 For habitable sailing multihulls which are considered to be vulnerable to inversion according to 7.11.2 or 7.11.3, it shall be shown by calculation using Annex D that, when inverted and/or fully flooded, the volume of buoyancy, expressed in cubic metres (m^3), in the hull, fittings and equipment is greater than the number represented by $(m_{LDC}/850)$, thus ensuring that it is sufficient to support the mass of the loaded boat by a margin. Habitable parts of the boat may not be included. Dedicated flotation elements (see 3.6.6) and watertight compartments not containing habitable parts of the boat may be included. Apart from these, allowance for trapped bubbles of air shall not be included.

7.12.2 The disposition of the buoyancy of the boat shall be such that, when the boat is inverted, it is highly probable that the boat will float with the upright design waterline less than 10° from the horizontal.

7.12.3 Where non-habitable compartments accessible via watertight hatches or doors are used to demonstrate positive flotation after inversion, the compartment shall be constructed to watertightness degree 1 (see ISO 11812), with hatches and doors satisfying the watertightness requirements for degree 2 of ISO 12216.

7.12.4 Closures to access openings into watertight compartments described in 7.12.3 shall be clearly marked in upper case letters not less than 4,8 mm high:

“KEEP SHUT WHEN UNDER WAY”

Where crew have access to both sides of such a closure, this marking shall be provided on both sides.

NOTE “Under way” has the meaning “not at anchor, or made fast to the shore, or aground”.

7.12.5 Where flotation elements are used, the requirements of Annex E apply.

7.13 Escape after inversion

7.13.1 For all habitable boats considered to be vulnerable to inversion according to 7.11.2 or 7.11.3, a “means of escape” to the exterior when the boat is inverted shall be accessible from each habitable part of the boat. A “means of escape” may comprise any of the following:

- a) a dedicated escape hatch, or
- b) a fixed panel held in place by a sealing strip and removable bead, or
- c) a “break-out panel” comprising either a predefined area of hull skin which can be broken through in an emergency using special tools, or a fixed panel that can be broken with a sharp implement, or
- d) for design category C and D, a normal access opening that is accessible by a short swim underwater (see 7.13.3 below).

NOTE A habitable boat is defined in 3.1.9. A habitable part of a boat is defined in 3.1.10.

7.13.2 Habitable multihull boats of design categories A and B, when the boat is floating in the inverted position in calm water at m_{LDC} , the highest edge of the means of escape opening shall be at least 0,2 m above the sea surface.

NOTE 1 Part of the escape opening may be underwater when the boat is inverted.

NOTE 2 In these categories, the probability of some crew being below deck is considered to be significant.

7.13.3 Habitable multihull boats of design categories C and D, when the boat is floating in the inverted position in calm water at m_{LDC} , the highest edge of the means of escape opening shall be less than 0,4 m below the sea surface.

When a normal access opening is intended to be used as a means of escape, the shortest length of a rope taken from the water level inside the habitable spaces through the means of escape, around guard-rails or guard-lines (if fitted) to the sea surface shall not be more than 5,0 m.

NOTE In these categories, the probability of some crew being below deck is considered to be limited.

7.13.4 Compliance with the requirements of 7.13.2 and 7.13.3 shall be demonstrated by either practical test or by calculation, excluding the buoyancy afforded by any air trapped inside the hulls apart from that in:

- dedicated flotation elements (see 3.6.6), or
- watertight compartments not containing habitable parts of the boat.

NOTE See Annex D.

7.13.5 Exit through such means of escape shall be possible in the inverted position from all habitable parts of the boat by means of permanently fixed foothold, ladder, step or other means. The size of such means of escape shall comply with ISO 9094. When the boat is inverted, the vertical distance between the upper foothold and the exit shall comply with ISO 9094.

7.13.6 Means of escape other than as permitted by 7.13.1 d) shall be fitted in the transom, inboard topsides of sidehulls or bridgedeck, and shall also be openable from outside, but are not required to be closable.

7.13.7 As far as practicable, means of escape shall be fitted in positions where local wave impact loads are minimized.

7.13.8 The lowest part of the opening of an escape hatch, window or panel shall be not less than 0,2 m (design category A or B) or 0,1 m (design category C or D) above the fully loaded waterline when the boat is upright.

7.13.9 Means of escape shall have a strength equivalent to the minimum requirements for the adjacent intact structure.

NOTE Refer to ISO 12215-7.

7.13.10 Where a “break-out panel” is used:

- a) tool(s) required shall be stowed inside the boat immediately adjacent to each “break-out panel”, and they shall also be accessible from outside the boat via a suitably-sized watertight hatch;
- b) a sign “Emergency escape panel – do not obstruct” in upper case letters not less than 12 mm high shall be permanently fixed on the outside and inside; and
- c) the ability of a person of average strength to break through the panel in less than one minute using the tool(s) provided shall be demonstrated on a panel of representative structure, and the method used documented in the owner’s manual.

8 Safety signs

Safety signs shall be placed where they are clearly visible, and shall be made of rigid plate or flexible labels affixed to the craft in such a way that they can only be removed by the use of tools. The size of the symbols and text shall comply with Table 10. Text shall be in black on a white background, using a plain sans serif typeface such as Arial Narrow. The language used shall be acceptable or as required in the country of intended use. The design of the signs shall comply with ISO 3864-1.

Table 10 — Size of safety signs and supplementary text

Parameter	Expected viewing distance, <i>D</i> (m)				
	$D \leq 0,6$	$0,6 < D \leq 1,2$	$1,2 < D \leq 1,8$	$1,8 < D \leq 2,4$	$D > 2,4$
Minimum height of warning sign (mm)	20,0	20,0	30,0	40,0	50,0
Minimum height of capital letters (mm)	2,4	4,8	7,2	9,6	12,0
Minimum height of lower case letters (mm) ^a	1,7	3,4	5,1	6,9	8,6

^a For example, height of letter "e".

9 Application

9.1 Deciding the design category

The design category for a particular boat is that for which the boat complies with all the appropriate requirements, as required by Clause 6 or Clause 7.

9.2 Meaning of the design categories

NOTE See Table 11.

9.2.1 A boat given design category A is considered to be designed to operate in winds of Beaufort force 10 or less and the associated wave heights, and to survive in more severe conditions. Such conditions may be encountered on extended voyages, for example across oceans, or inshore when unsheltered from the wind and waves for several hundred nautical miles. Winds are assumed to gust to 28 m/s.

9.2.2 A boat given design category B is considered to be designed for waves of up to 4 m significant height and a wind of Beaufort force 8 or less. Such conditions may be encountered on offshore voyages of sufficient length or on coasts where shelter may not always be immediately available. Such conditions may also be experienced on inland seas of sufficient size for the wave height to be generated. Winds are assumed to gust to 21 m/s.

9.2.3 A boat given design category C is considered to be designed for waves of up to 2 m significant height and a typical steady wind force of Beaufort force 6 or less. Such conditions may be encountered on exposed inland waters, in estuaries, and in coastal waters in moderate weather conditions. Winds are assumed to gust to 17 m/s.

9.2.4 A boat given design category D is considered to be designed for waves of up to 0,3 m significant height and occasional waves of 0,5 m height and a typical steady wind force of Beaufort force 4 or less. Such conditions may be encountered on sheltered inland waters, and in coastal waters in fine weather. Winds are assumed to gust to 13 m/s.

9.2.5 The significant wave height is the mean height of the highest one-third of the waves, which approximately corresponds to the wave height estimated by an experienced observer. Some waves will be double this height.

Table 11 — Summary of design category conditions

Parameter	Design category			
	A	B	C	D
Maximum wave height	approx. 7 m significant	4 m significant	2 m significant	0,3 m significant 0,5 m maximum
Typical Beaufort wind force	≤10	≤8	≤6	≤4
Calculation wind speed (m/s)	28	21	17	13

NOTE The definitions of these design categories align with those used in the Recreational Craft Directive of the European Union, EU Directive 94/25/EC as amended by Directive 2003/44/EC.

Annex A (normative)

Full method for required downflooding height

The required downflooding height may be calculated according to the method set out below instead of using Figure 2. In all cases, the limits given in Table A.1 apply to the required height calculated by the formula below.

Table A.1 — Limits on required downflooding height

Dimensions in metres

Design category	A	B	C	D
$h_{D(R)}$ (m) shall be not less than	0,5	0,4	0,3	0,2
$h_{D(R)}$ (m) shall be not more than	1,41	1,41	0,75	0,4

The downflooding height required ($h_{D(R)}$) is calculated separately for each downflooding opening as follows:

$$h_{D(R)} = H_1 \times F_1 \times F_2 \times F_3 \times F_4 \times F_5 \tag{A.1}$$

where

$$H_1 = L_H/15;$$

F_1 is the opening position factor (varies between 0,5 and 1,0),
 = 1,0 where the downflooding opening is in the periphery of the boat, e.g. for undecked, open boats, or openings in topsides:

$$F_1 = (1 - x_D/L_H) \text{ or } (1 - y_D/B_H), \tag{A.2}$$

whichever is greater, see Figure A.1.

where

x_D is the longitudinal distance of a downflooding opening from the nearest extremity of L_H ;

y_D is the least transverse distance of a downflooding opening from the periphery of the boat.

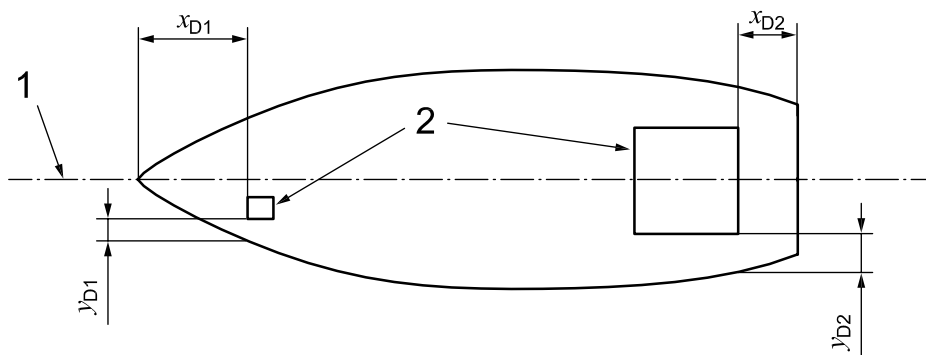

Key

- 1 centreline
- 2 downflooding openings

Figure A.1 — Dimensions x_D and y_D

F_2 is the opening size factor (varies between 0,6 and 1,0):

$$F_2 = 1,0, \text{ if } a \geq (30L_H)^2 \quad (\text{A.3})$$

where

a is the total combined area of openings up to the top of any downflooding opening, expressed in square millimetres (mm²);

$$F_2 = 1 + \frac{x'_D}{L_H} \left(\frac{\sqrt{a}}{75L_H} - 0,4 \right) \text{ if } a < (30L_H)^2; \quad (\text{A.4})$$

where

x'_D is the longitudinal distance of the opening from the forward limit of L_H .

F_3 is the recess size factor, greater than 0,7 but never to be taken as greater than 1,2:

= 1,0 where the opening is not a recess, otherwise:

= 0,7 if the recess is quick-draining;

= 0,7 + $k^{0,5}$ if the recess is not quick-draining;

where

$$k = V_R / (L_H B_H F_M) \quad (\text{A.5})$$

where

V_R is the volume of a non-quick-draining recess, expressed in cubic metres.

F_4 is the displacement factor (typically this is between about 0,7 and 1,1):

$$F_4 = \left(\frac{10 V_D}{L_H B^2} \right)^{1/3} \quad (\text{A.6})$$

where

V_D is the volume of displacement in the maximum load condition, $V_D = m_{LDC} / 1\,025$;

B is B_H for monohull, and B_{WL} for catamarans and trimarans.

F_5 is the flotation factor:

= 0,8 for boats using options 3 and 4 (see Table 2);

= 1,0 for all other boats.

Annex B (normative)

Methods for calculating downflooding angle

B.1 Choice of method

Either of the methods B.2 or B.3 can be used.

B.2 Theoretical calculation

The downflooding angle is most accurately determined by computer calculation, using the shape of the hull from the lines plan. Most software packages for calculating stability have provision for finding the angle of heel at which points with specified coordinates become submerged. Thus, if righting moments are determined using computer software, downflooding angles can be obtained at the same time.

B.3 Approximate method for downflooding angles up to 60°

The following approximate method can be used for estimating the downflooding angle of monohulls, but is only suitable for angles less than about 60°:

$$\phi_D = \tan^{-1}(z_D / y'_D) \quad (\text{B.1})$$

$$\phi_D \text{ is the angle whose tangent is } (z_D / y'_D) \quad (\text{B.2})$$

where

z_D is the height of the downflooding point above the waterline, expressed in metres;

y'_D is the transverse distance, expressed in metres, of the downflooding point from the centreline of the boat.

See Table B.1 and Figure B.1.

Table B.1 — Approximate method for downflooding angle

z_D / y'_D	ϕ_D degrees
0,10	5,7
0,15	8,5
0,20	11,3
0,25	14,0
0,30	16,7
0,35	19,3
0,40	21,8
0,45	24,2
0,50	26,6
0,55	28,8
0,60	31,0
0,65	33,0
0,70	35,0
0,75	36,9
0,80	38,7
0,85	40,4
0,90	42,0
0,95	43,5
1,00	45,0
1,05	46,4
1,10	47,7
1,15	49,0
1,20	50,2
1,30	52,4
1,40	54,5
1,50	56,3
1,60	58,0
1,70	59,5

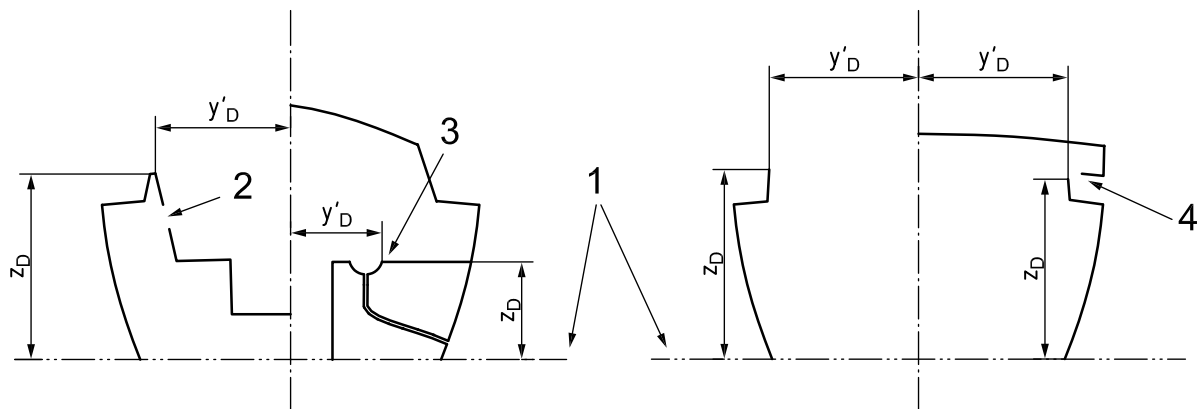

Key

- 1 waterline
- 2 downflooding opening protected by coaming
- 3 example of internal downflooding opening
- 4 example of engine air inlet

Figure B.1 — Approximate method for downflooding angle

Annex C (normative)

Determining the curve of righting moments

C.1 Method

The curve of righting moments shall be determined using the method described in C.3. The mass and centre of gravity used shall conform to C.2.

C.2 Mass and centre of gravity

Where preliminary estimates are used at the design stage, these shall be subsequently superseded by the use of data for the boat as finally built.

C.2.1 Mass

The mass used can be found using any of the following methods:

- a) direct weighing using crane weigher, weighbridge, load cells or similar, corrected to the appropriate displacement mass;
- b) calculation from the lines plan using a waterline observed on a boat afloat in a known load condition, by means of freeboards or draughts, and using a measured specific gravity for the water, and corrected to the appropriate loading condition;
- c) calculation based on the mass of a closely similar boat derived by either a) or b) above, with the mass of known changes determined solely by calculation.

Method c) shall only be used where the change in mass in the empty craft condition is less than 10 %.

C.2.2 Vertical centre of gravity

The vertical position of the centre of gravity (VCG) can be found using any of the following methods:

- a) an inclining experiment in water (see 3.6.7), the results being corrected to the appropriate loading condition;
- b) an inclining experiment in air using a known length of suspension and moving weights transversely (as in water), the results being corrected to the appropriate loading condition;
- c) calculation based on the calculated mass and centres of gravity of all individual components, raised by an addition of 5 % of $(F_M + T_C)$.

In deriving the VCG, any centreboard or keel shall be in the raised position unless it can be fixed in the lowered position and an appropriate instruction is given in the owner's manual.

Method a) shall not be used for boats with a metacentric height greater than 5,0 m (such as multihulls), since inclining experiments in water for such boats are liable to significant inaccuracies.

Method c) shall not be used for boats with a metacentric height of less than 1,5 m, since significant inaccuracies may result. It may, however, be used for preliminary assessment.

For the purposes of determining the curve of righting levers:

- a) for calculations for the minimum operating condition: the mass of the crew shall be at the main control position;

- b) for calculations for the loaded arrival condition:
- 1) fuel and water shall be located in the fixed tanks,
 - 2) provisions shall be stowed in an appropriate location,
 - 3) the mass of additional crew (crew limit less that required for m_{MO}) shall be added at sheerline height at the mid-length of L_H .

C.2.3 Longitudinal centre of gravity

The longitudinal position of the centre of gravity (LCG) of the empty boat can be found using any of the following methods:

- a) method b) or c) in C.2.1;
- b) calculation based on the calculated mass and centres of gravity of all individual components;
- c) suspension of the boat in air, identifying the LCG using a plumb line from the suspension point.

C.2.4 Free-surface effect

Boats having any tank (fuel, fresh, black and grey water, live wells, oils, etc.) that has a maximum transverse dimension greater than $0,35B_H$ shall have their righting moments calculated with the contents of all tanks as given in Table C.1.

If tanks are linked by cross-connections that are kept open when the boat is in use, then the maximum transverse dimension of such a tank shall be measured between the extremes of the linked tanks.

Table C.1 — Contents of tanks for calculation of righting moments

Tank	Loading condition	
	Loaded arrival	Minimum operating
Fuel	10 %	0 %
Fresh water	10 %	0 %
Black/grey water	95 %	0 %
Oils	10 %	0 %
Bait tanks, live wells	95 %	0 %

Where applicable, free-surface effect shall be represented either by a virtual increase in the boat's VCG (see below) or by using computer software that models the movement of fluid in tanks with trim and heel.

$$\text{virtual increase in the boat's VCG due to each tank} = \frac{SMA_{TANK} \times \rho_{TANK}}{m}, \text{ expressed in metres} \quad (C.1)$$

where

ρ_{TANK} is the density of fluid in tank, expressed in kg/m^3

m is the mass of the boat in the relevant loading condition, expressed in kilograms

SMA_{TANK} is the second moment of area of waterplane of tank contents about longitudinal axis through its centre of area, expressed in m^4

If tanks are linked by cross-connections that are kept open when the boat is in use, then the value of SMA_{TANK} shall be calculated assuming that all linked tanks act as one.

C.3 Determination by rigorous calculation

C.3.1 The curve of righting levers for a boat in calm water is most accurately determined by computer calculation, using specialist software which correctly takes account of the changes in trim and heave that take place as a boat heels. It is desirable wherever possible to use a vertical position of the centre of gravity (VCG) which has been derived from an inclining experiment, except in the case of boats with exceptionally high initial stability (such as multihulls) when a careful calculation of VCG will prove more accurate. The longitudinal position of the centre of gravity (LCG) shall be derived by calculation from the longitudinal centre of buoyancy obtained from the inclining experiment.

C.3.2 In defining the watertight hull, cockpits, recesses, bow thruster tunnels and all appendages affecting the buoyancy shall be correctly represented. Righting lever curves shall normally be calculated with recesses modelled, assuming that, at each heel angle, such recesses flood up to the exterior water level. However, up to the angle of heel at which recesses would otherwise fill (e.g. coaming submergence), righting levers may alternatively be calculated ignoring flooding of recesses through

- freeing ports equipped with non-return flaps which are watertight from the exterior to degree 3 of ISO 12216, or
- drains having a combined cross-sectional area smaller than three times the minimum area required to comply with ISO 11812 for quick-draining cockpits.

C.3.3 The buoyancy of superstructures and deckhouses may be included in the calculation, provided that the structure (including windows) is both watertight in accordance with ISO 12216 and has sufficient structural strength to survive the boat being rolled to a heel angle through 180°.

C.3.4 The buoyancy of masts and standing rigging (but not booms, gaffs or running rigging) may be included in the calculation of righting lever if desired. In this case, only the buoyant volume shall be included, i.e. the internal volume of free-flooding or non-watertight masts shall not be included. The effect of the mass of masts is included in the inclining experiment results.

C.3.5 Righting moment is equal to the righting lever in metres multiplied by the boat mass in kilograms multiplied by 9,806, and is expressed in newton metres.

Annex D (normative)

Method for calculating reserve of buoyancy after inversion or swamping

D.1 Introduction

D.2 sets out the calculation method for complying with the flotation requirement of 6.9 and 7.12, by showing that when a swamped or inverted boat is totally immersed, the buoyancy available from the hull structure, fittings and flotation elements exceeds that required to support the loaded displacement mass by a defined margin.

D.2 Method

D.2.1 Calculate the volume of the various elements of the boat by direct calculation and/or from a knowledge of the mass and density of the different materials, using the expression

$$V = m / \rho \quad (D.1)$$

where

- V is the volume of an element, expressed in cubic metres;
- m is the mass of that element, expressed in kilograms;
- ρ is the density of that element, expressed in kilograms per cubic metre.

D.2.2 Calculate the total buoyant volume of the boat, V_B , by adding together the volumes of

- the hull structure (see Table D.1),
- the gross volume of fixed tanks for fuel, water, or other stowed fluids,
- the gross volume of air tanks or containers meeting the requirements of Annex E, and
- the volume of non-habitable watertight compartments, fitted with doors or hatches watertight to degree 2 and without any downflooding openings.

The buoyant volume of engines and other fittings and equipment may also be included (see Table D.1). Omitting them will enhance the safety margin.

No allowance shall be included for trapped bubbles of air, or for crew, masts, sails and rigging.

D.2.3 Show that

$$V_B > m_{LDC}/850 \quad (D.2)$$

where

- V_B is the total buoyant volume of the boat, expressed in cubic metres (m³), calculated in D.2.2.

D.3 Material densities

The densities in Table D.1 shall be used in calculating the volume of components.

Table D.1 — Material densities

Densities in kilograms per cubic metre

Material	Density
Lead	11 400
Bronze	8 900
Brass (65/35)	8 450
Steel	7 800
Cast iron	7 300
Aluminium alloys	2 700
GRP laminate	1 500
Flotation foam materials	40
Structural foam materials	80
Balsa core material	150
Oak	770
Teak	640
Mahogany	550
Miscellaneous equipment	2 000
Food and other stores	2 000
Stowed sails and ropes	1 200
Window glass	2 500
Window plastic	1 200
Diesel engines	5 000
Petrol engines	4 000
Outboard engines	3 000
Sail-drive struts	3 000
stern-drive struts	3 000
Plywood	600
Western red cedar	370
Spruce	430

Annex E (normative)

Flotation material and elements

E.1 Requirements

Flotation elements as defined in 3.6.6 shall comply with the requirements in Table E.1. Other types of flotation elements shall be evaluated following the same principles.

Those materials or parts of the boat which are not primarily intended to provide flotation but which nevertheless contribute to the flotation characteristics shall not be subject to the requirements in this annex.

Table E.1 — Requirements for flotation elements

Property	Air tank	Air container	Inflated bag	Low density material
Airtightness	RT	RT	R	—
Mechanical robustness or protection	R	R	R	R
Draining facility	R	R	—	—
Resistant to or protected from sunlight	—	R	R	R
Fitted with an inflation point	—	—	R	—
Temperature resistant –40 °C to +60 °C	—	—	—	R
Water absorption max. 8 % by volume	—	—	—	R
Securely fastened to withstand buoyancy force	—	R	R	R
Encapsulated or resistant to liquids	—	—	R	R
Label: "Do not puncture air tank/container/bag"	R	R	R	—
NOTE 1 R denotes that this property is required but is not subject to a specific test by the builder.				
NOTE 2 RT denotes that this property is required, and is required to be tested by the builder.				

E.2 Tests

The water absorption of low density material shall not exceed 8 % by volume after being submerged for 8 d according to ISO 2896.

NOTE Materials complying with the requirements of IMO Resolution MSC.81(70) Part 1^[5], Clauses 2.7.5 to 2.7.8 are deemed to satisfy this requirement.

Where air tanks or air containers are used, they shall be subject to a pressure test, carried out at an initial over-pressure, with a permitted pressure drop within 30 s, as given in Table E.2.

Boats intended to be fitted with engines of more than 3 kW and which are fitted with integral air tanks which have laminated, glued, welded or bolted seams in their construction, and which air tanks do not comply with the enhanced pressure test, shall have a number of air chambers opened to atmosphere during testing, according to Table E.3.

Table E.2 — Test pressures

Condition	Enhanced pressure test	Basic pressure test
Chambers required to be opened during flotation tests	None	As detailed in Table E.3
Initial over-pressure	2,5 kPa (250 mm water)	1,25 kPa (125 mm water)
Maximum pressure drop in 30 s	1,0 kPa (100 mm water)	0,75 kPa (75 mm water)

Table E.3 — Number of air chambers to be considered ineffective

Total number of air tanks or air containers	Number to be considered ineffective
≤ 4	Single largest
> 4 but ≤ 8	Two largest
> 8	Three largest

For boats being assessed using options 3, 5 or 7 of Table 2, breather holes in air tanks designed for the relief of air pressure due to variations in ambient temperature may be temporarily sealed during testing, provided that their position does not alter the effectiveness of the tank during the flotation tests required by 6.9 or 6.10.

Annex F (normative)

Information for owner’s manual

F.1 General information

The following stability information, as appropriate to the design, shall be included in the owner’s manual defined in ISO 10240:

A maximum load has been used for assessing stability and buoyancy comprising

- manufacturer’s maximum recommended load kg
 - fuel, fresh water, other fluids to maximum capacity of fixed tanks kg
-
- Maximum load kg

This assessment has been made assuming that

- the boat in the empty craft condition has a mass of kg
- the boat in the light craft condition has a mass of kg
- the maximum recommended outboard engine mass is kg
- all standard equipment is aboard.

F.2 Specific information

If appropriate, the following information should be included in the owner’s manual.

- a) **IMPORTANT:** The water ballast tanks located are intended to be completely full whenever the boat is afloat (*where applicable*).
- b) **IMPORTANT:** This boat is only intended to be sailed with the centreboard or drop keel locked in the lowered position (*where the stability has only been assessed in this condition, see 6.7.2, 6.8.2 and C.2.2*).
- c) The ballast tanks located may be filled with variable amounts of liquid to suit the sailing conditions. When using this ballast, the boat still satisfies the requirements for its design category, even with the ballast positioned to leeward (*where applicable*).
- d) The position of movable solid ballast may be varied to suit the sailing conditions. When using this ballast, the boat still satisfies the requirements for its design category, even when the ballast is deployed to leeward (*where applicable*).
- e) This boat has been assessed using the Stability Index (STIX), which is a measure of the overall stability safety and considers the effects of boat length, displacement, hull proportions, stability characteristics and resistance to downflooding. This assessment has yielded the following data:

	Minimum operating condition	Loaded arrival condition
STIX
Angle of vanishing stability (degrees)

- f) This boat has been assessed as capable of supporting the crew even when swamped (when meeting the requirements of 6.9 or 7.12).
- g) The following openings are marked “KEEP SHUT WHEN UNDER WAY”, and care should be taken to observe this warning: (insert list of relevant opening locations). “Under way” has the meaning “not at anchor, or made fast to the shore, or aground”. (Text to be inserted when required according to 6.2.1.6, 6.5.2, 6.9.2 or 7.12.4).
- h) This sailing boat is intended to be recovered by the crew after a capsize. The minimum crew mass needed is kg, and the following technique is recommended (*insert as appropriate*). The likelihood of capsize of this boat when being used in normal circumstances is ... (*boats using 6.10.*) If the boat is fitted with a cabin, users should be aware that persons inside may become trapped after a capsize.

The following safety signs warn of these hazards.

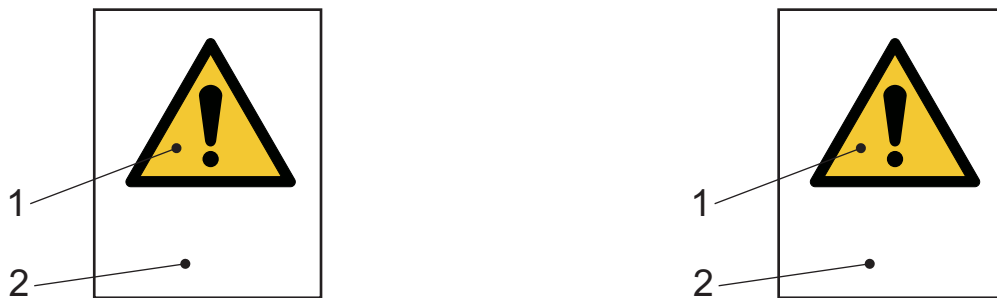

Key

- 1 sign W001 “General warning” from ISO 7010
- 2 supplementary text to read “Risk of capsizing!”

a) Where there is no cabin

Key

- 1 sign W001 “General warning” from ISO 7010
- 2 supplementary text to read “Risk of capsizing! Persons in cabin may be trapped!”

b) Where boat is fitted with a cabin

Figure F.1 — “Risk of capsizing” safety signs

- i) This boat may swamp or capsize if excessive sail is carried. It may sink if this occurs. The working sail plan should be reduced if the apparent wind exceeds ... knots/metres per second. Particular care should be taken in gusty wind conditions. (*Boats assessed using Table 2, Option 5.*) or

This boat may swamp or capsize if excessive sail is carried. It is designed not to sink if this occurs. The working sail plan should be reduced if the apparent wind exceeds ... knots/metres per second. Particular care should be taken in gusty wind conditions. (*Boats assessed using Table 2, Option 6.*) or

This boat may capsize and remain inverted if excessive sail is carried. It is designed not to sink if this occurs. The working sail plan should be reduced if the apparent wind exceeds ... knots/metres per second. Other stability hazards are ... (*see 7.5 and insert as appropriate*) (*boats assessed using 6.5.2 or Clause 7*).

The following safety signs warn of this hazard.

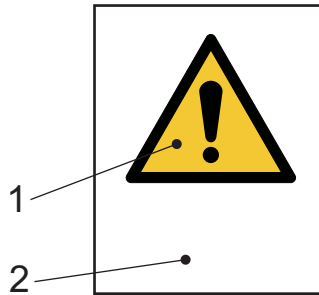

Key

- 1 sign W001 “General warning” from ISO 7010
- 2 supplementary text to read “Reef sails at N knots (or m/s) apparent wind speed”, where N is the relevant wind speed

a) Fully enclosed boats

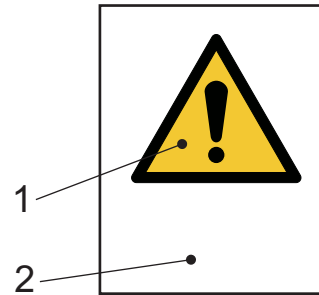

Key

- 1 sign W001 “General warning” from ISO 7010
- 2 supplementary text to read “Reef sails before water enters, or boat will flood and may not recover”

b) Other boats

Figure F.2 — Reefing safety signs

- j) If the boat has been assessed using 6.5.2 or Clause 7, a table similar to Table F.1 shall be provided.

Table F.1 — Stability data for catamarans, trimarans and monohulls using 6.5.2

STABILITY DATA		
For the boat:		
Prepared by:		
Date:		
Method used: calculation/ sailing trials (<i>delete whichever is not applicable</i>)		
Minimum operating condition mass = kg = tonnes		
Maximum load condition mass = kg = tonnes		
Sails set	Maximum apparent wind speed advised for each sail combination (knots or m/s)	
	Minimum operating condition	Maximum load condition <i>(optional)</i>
Main sail + light weather jib		
Main sail + working genoa		
Main sail + working jib		
First reef in main sail + small jib		
Second reef in main sail + small jib		
Third reef in main sail + storm jib		
Small jib		
Storm jib		
<p>NB: The above list of sail combinations may be varied as appropriate to the rig of the boat. The following notes may be varied at the discretion of the builder.</p> <p>NOTE 1 If excessive sail is carried, THIS BOAT MAY CAPSIZE, but is designed not to sink if this occurs.</p> <p>NOTE 2 The wind strengths tabulated above include a margin for the effect of gusts. In violent winds or confused or breaking seas, additional caution should be exercised.</p> <p>NOTE 3 In the event of a severe gust, FREE SHEETS If wind is close-hauled, LUFF UP If wind is abeam, FREE SHEETS If wind is abaft the beam, BEAR AWAY</p> <p>NOTE 4 Special care should be taken when turning from a following wind onto a beam reach, because both the apparent wind speed and heeling effect will increase. Such turns should not be made rapidly, and consideration should be given to a reduction in sail before such a manoeuvre.</p>		

Annex G (normative)

Determination of safe wind speed information

G.1 Method

G.1.1 This annex describes the methods which may be used to calculate the wind speed information to be placed in the owner's manual, as required by 6.5.2 or 7.5, and for calculating the bare poles factor in 7.7.

Determine the mass in the minimum operating condition and associated centre of gravity position in accordance with Annex C. Calculations may also be conducted using the mass in the maximum load condition, if desired.

Calculate the limiting righting moments in accordance with G.2, using either rigorous or approximate methods for catamarans, but only rigorous method for monohulls and trimarans.

For each combination of sails set and load condition, find the wind speed limit for the stability data in the owner's manual as below, adopting the lesser value obtained from:

- limiting transverse righting moment (LM_T), and
- limiting longitudinal righting moment (LM_L)

where

LM_T is defined in G.2.1 and LM_L is defined in G.2.2.

G.1.2 The bare poles speed (v_{BP}) based on the limiting transverse righting moment is calculated from:

$$v_{BP} = 1,85 \sqrt{\frac{LM_T}{0,8 \sum(A_{BP}h_{BP}) + \sum(A_{WM}h_{WM})}} \quad (G.1)$$

where

v_{BP} is the bare poles speed, expressed in knots;

$\sum(A_{BP}h_{BP})$ is the sum of the products of the lateral profile area of the hull plus each item of the rig and the height of the centroid of each above the geometric centre of the below-water profile of the hull (with centre- or dagger-boards lowered and boat upright), expressed in m^3 . Items of rig to be included are:

- mast(s) and boom(s) (but excluding wing masts),
- any antennae or fittings (such as radar scanner, radar reflector or equipment mast) with a profile area greater than $0,01m^2$,
- standing rigging,
- sails stowed on booms,
- any roller furled sails (other than in-mast furling sails);

$\sum(A_{WM}h_{WM})$ is the sum of the products of the lateral profile areas of wing masts (if fitted) and the height of the centroid of each above the geometric centre of the below-water profile of the hull (with centre- or dagger-boards lowered and boat upright), expressed in m^3 .

NOTE 1 The area of standing rigging may be taken as 0,16 of the lateral profile area of a non-wing mast.

NOTE 2 The area of a roller furled sail may be taken as $L_L(0,025 + L_P/60)$, where L_L is the luff length (m) and L_P is the length of the perpendicular from clew to luff (m).

NOTE 3 The profile area of sails stowed on a boom may be taken as the area of the sail divided by 25.

G.1.3 The wind speed limit (v_W) based on the limiting transverse righting moment is calculated from:

$$v_W = 1,85 \sqrt{\frac{LM_T}{0,8\Sigma(A_H h_H) + \Sigma(A_S h_S)}} \quad (G.2)$$

where

v_W is the wind speed, expressed in knots;

$\Sigma(A_H h_H)$ is the sum of the products of the lateral profile area of the hull plus each item of the rig and the height of the centroid of each above the geometric centre of the below-water profile of the hull (with centre- or dagger-boards lowered and boat upright), expressed in m^3 . Items of rig to be included are:

- mast(s) and boom(s) (but excluding wing masts),
- any antennae or fittings (such as radar scanner, radar reflector or equipment mast) with a profile area greater than $0,01 m^2$,
- standing rigging,

$\Sigma(A_S h_S)$ is the sum of the products of the lateral profile area of each sail and the height of the centroid of each above the geometric centre of the below-water profile of the hull (with centre- or dagger-boards lowered, and boat upright), expressed in m^3 .

NOTE Rotating wing masts are treated as sails.

G.1.4 The wind speed limit (v_W) or bare poles speed (v_{BP}) based on the limiting longitudinal righting moment is calculated in a similar manner to G.1.2 and G.1.3 but utilizing:

- the limiting longitudinal righting moment (LM_L) instead of the transverse moment (LM_T),
- the frontal area instead of the lateral profile area for the hull and mast(s),
- the height of the centroid of each element above the waterline instead of to the geometric centre of the below-water profile of the hull.

G.2 Limiting righting moments

G.2.1 Transverse

The limiting transverse righting moment, LM_T , is the maximum righting moment, in newton metres. This may be found rigorously according to C.3, or for catamarans where $B_{CB} > 6T_C$ approximately from:

$$LM_T = 9,4m(0,5B_{CB}\cos\phi_{GZmax} - VCG\sin\phi_{GZmax}) \quad (G.3)$$

where

m is the mass of the boat, expressed in kilograms;

VCG is the height of the centre of gravity above the bottom of the canoe body, expressed in metres, which may be conservatively taken as the height of the sheerline at mid-length of L_{WL} ;

ϕ_{GZmax} is the estimated angle of heel of maximum righting lever, expressed in degrees:

$$\phi_{GZmax} = \tan^{-1} \left(\frac{m}{254 L_{WL} B_{WL} B_{CB}} \right) \quad (G.4)$$

G.2.2 Longitudinal

The limiting longitudinal righting moment (LM_L), in newton metres, is determined for the bow-down trim angle (from the design trim) which is the least of the following:

- the angle at which the foredeck at the stem is about to become immersed;
- 20°.

LM_L , in newton metres, may be calculated using the methods of Annex H,

where

m is the mass of the boat, expressed in kilograms;

A_W is the total waterplane area of all hulls at design waterline, expressed in square metres.

NOTE “Bow down trim” describes the trim where the bow is being depressed compared to the design trim.

Annex H (normative)

Determination of longitudinal righting characteristics

H.1 General

Limiting longitudinal righting moment is the longitudinal righting moment required to be applied to a boat at design trim in order to attain a bow-down trim angle of 20° or immersion of the upper deck at the stem, whichever occurs earlier.

Limiting longitudinal righting moment area is the area under the curve of longitudinal righting moments, and is expressed in kilonewton metre radians, calculated from design trim to a bow-down trim angle of 20° or immersion of the weather deck at the stem, whichever occurs earlier.

These parameters may be determined using any of the methods below.

H.2 Approximate methods

These methods are only valid for catamarans and for trim by the bow (i.e. bow down).

The limiting longitudinal righting moment (LM_L , kN·m) may be estimated from:

$$\frac{\theta_L \cdot B_{WL} \cdot (L_H + L_{WL})^3}{3\,000} \quad (\text{H.1})$$

The limiting longitudinal righting moment area (kN·m·rad) may be estimated from:

$$\frac{\theta_L^2 \cdot B_{WL} \cdot (L_H + L_{WL})^3}{300\,000} \quad (\text{H.2})$$

where

- θ_L is the limiting trim angle (degrees), being the lesser of 20° or the angle of immersion of the weather deck at the stem. The latter may be estimated from: $1,4 \tan^{-1} [F_S / (R + L_B)]$;
- B_{WL} is the sum of maximum waterline beams of all individual hulls (see 3.4.5);
- F_S is the vertical freeboard from waterline to intersection of line of foredeck and outer stem;
- R is the bow rake, i.e. the longitudinal distance from intersection of line of weather deck and outer stem to forward end of waterline;
- L_B is the longitudinal distance from longitudinal centre of buoyancy of immersed hulls at design trim to forward end of waterline.

NOTE 1 In general, parameters above are for the boat in the minimum operating condition. If safe wind speed information according to Annex G is to be provided for the maximum load condition, then the data are also required for that loading condition.

NOTE 2 The weather deck at the stem comprises a watertight deck, excluding any bulwarks or raised stem post.

H.3 Simplified methods

These methods require the use of a lines plan and computer software capable of calculating the static equilibrium waterline and transverse stability. The longitudinal righting moment area may be determined from the longitudinal righting lever curve.

These methods are valid for trim either by the bow (i.e. bow down) or by the stern (i.e. stern down).

H.3.1 Longitudinal righting moment

The longitudinal righting lever curve can be obtained using a conventional computer stability program as follows:

- a) Find the LCG for design trim from the LCB, using hydrostatics data.
- b) Move the LCG forward in a series of arbitrary steps, retaining the original VCG.
- c) At each step in LCG find the equilibrium trim angle and the height to immersion of the foredeck at the stem.
- d) At each step calculate the longitudinal righting lever from:

$$GZ_L = (\text{change in LCG from design trim}) \cos(\text{trim angle}).$$
- e) At each step calculate longitudinal righting moment = $(m_{MO}GZ_L)/102$ (kN·m).
- f) Graph longitudinal righting moment and height to immersion of the foredeck against trim angle.
- g) Determine whether or not the foredeck becomes immersed at a trim angle less than 20°. The limiting trim angle is the lesser of 20° and the angle at which the immersion of the weather deck at the stem (main hull for trimarans).
- h) Determine the limiting longitudinal righting moment and calculate the longitudinal righting moment area to the limiting trim angle from the graph, and convert to kN·m·rad by dividing by 57,296.

NOTE 1 LM_L (required by Annex G) is the longitudinal righting moment at the limiting trim angle, expressed in kilonewton-metres.

NOTE 2 The weather deck at the stem comprises a watertight deck, excluding any bulwarks or raised stem post.

H.3.2 Transverse righting moment when trimmed

The transverse righting moment at 1° heel when trimmed may be calculated as follows:

- a) Find the LCG and GZ_L at the limiting trim angle from the calculations conducted according to H.3.1 above.
- b) Calculate the transverse GM for the boat when trimmed (GM_{TT}) using:
 - 1) LCG as in a) above, and
 - 2) $VCG = (\text{original VCG}) + [GZ_L \times \tan(\text{limiting trim angle})]$
- c) Calculate the transverse righting moment at 1° heel when trimmed = $0,01745m_{MO}GM_{TT}$ (N·m).

H.4 Rigorous method

This method requires the use of either:

- computer software capable of calculating longitudinal as well as transverse righting moments, or
- a three-dimensional computer model of the hull, which may be used to generate closely spaced longitudinal sections, which may then be used in conventional naval architecture software to calculate the pitch righting moments.

This method is valid for trim either by the bow (i.e. bow down) or by the stern (i.e. stern down).

The righting moment at 1° heel when trimmed may be calculated using the method of H.3.2 above except that LCG and GZ_L at the limiting trim angle are determined directly.

Annex I (informative)

Summary of requirements

The design category given in respect of stability and buoyancy is that for which the boat satisfies all the requirements according to 6.1 as summarized in Table I.1, or 7.1 as summarized in Table I.2.

Table I.1 — Summary of requirements for monohulls

Option number		1		2		3	
		A	B	C	D	C	D
Decking or covering	All boats	—	—	—	—	—	—
	All boats except "fully enclosed"	—	—	—	—	yes	yes
	Fully enclosed boats (see 3.1.8)	yes	yes	yes	yes	—	—
Downflooding openings (see 6.2.1)		yes	yes	yes	yes	yes	yes
Required downflooding height (using figures) (6.2.2)	Not to be less than	0,5	0,4	0,3	0,2	0,3	0,2
	Not to be less than	$L_H/17$	$L_H/17$	$L_H/17$	$L_H/17$	$L_H/17$	$L_H/17$
	Need not be more than	1,41	1,41	0,75	0,4	0,75	0,4
Required downflooding height (by Annex A, 6.2.2)	Not to be less than	0,5	0,4	0,3	0,2	0,3	0,2
	Need not be more than	1,41	1,41	0,75	0,4	0,75	0,4
Downflooding angle (6.2.3)	ϕ_D to be >	40°	40°	35°	30°	—	—
Recess size (6.3) only if using 6.5.2 and $\phi_V < 90^\circ$	max % loss in GM_T	—	$550F_R/L_H$	—	—	—	—
Righting energy (6.4)	$m_{MO} \cdot A_{GZ} >$	172 000	57 000	—	—	—	—
Angle of vanishing stability (6.5.1)	ϕ_V to be >	$(130 - 2M)^a$	$(130 - 5M)^a$	90°	75°	—	—
	also ϕ_V to be >	100°	95°	—	—	—	—
Angle of vanishing stability (6.5.2)	ϕ_V to be >	—	$(130 - 5M)^a$	—	—	—	—
	and flotation: $V_B >$ and stability information	—	and >75° $m_{LDC}/850$ as 7.4	—	—	—	—
Stability index (6.6)	STIX to be >	32	23	14	5	—	—
Knockdown-recovery test (6.7)		—	—	—	—	yes	yes
Wind stiffness test (6.8)		—	—	—	—	—	—
Flotation requirements (6.9)		—	—	—	—	—	—
Capsize-recovery test (6.10)		—	—	—	—	—	—
Detection and removal of water (6.11)		yes	yes	yes	yes	yes	yes

^a $M = m / 1\ 000$.

	Option number	4	5		6		7
	Design category	C and D	C	D	C	D	C and D
Decking or covering	All boats	—	yes	yes	yes	yes	—
	All boats except "fully enclosed" (see 3.1.8)	yes	—	—	—	—	yes
	Fully enclosed boats (see 3.1.8)	—	—	—	—	—	—
Downflooding openings (see 6.2.1)		yes	yes	yes	yes	yes	—
Required downflooding height (using figures, 6.2.2)	Not to be less than	—	0,3	0,2	—	—	—
	Not to be less than	—	$L_H/17$	$L_H/17$	—	—	—
	Need not be more than	—	0,75	0,4	—	—	—
Required downflooding height (by Annex A, 6.2.2)	Not to be less than	—	0,3	0,2	—	—	—
	Need not be more than	—	0,75	0,4	—	—	—
Downflooding angle (6.2.3)	ϕ_{DA} to be >	—	—	—	—	—	—
Recess size (6.3) <i>only if fully enclosed</i>	max % loss in GM_T	—	$1200 F_R/L_H$	—	$1200 F_R/L_H$	—	—
Righting energy (6.4)	$m_{MO} \cdot A_{GZ} >$	—	—	—	—	—	—
Angle of vanishing stability (6.5)	ϕ_V to be >	—	—	—	—	—	—
Stability index (6.6)	STIX to be >	—	—	—	—	—	—
Knockdown-recovery test (6.7)		yes	—	—	—	—	—
Wind stiffness test (6.8)		—	$v_{AW} > 13$	$v_{AW} > 8$	$v_{AW} > 11$	$v_{AW} > 6$	—
Flotation requirements (6.9)		$m_{LDC}/850$	—	—	$m_{LDC}/850$	$m_{LDC}/850$	—
Capsize-recovery test (6.10)		—	—	—	—	—	yes
Detection and removal of water (6.11)		yes	yes	yes	yes	yes	yes

Table I.2 — Summary of requirements for catamarans and trimarans

Configuration or requirement	Design category	A	B	C	D
Decking or covering	Any amount	—	—	yes	yes
	Fully enclosed (see 3.1.8)	yes	yes	—	—
Downflooding openings (see 6.2.1)		yes	yes	yes	yes
Required downflooding height (using figures, 6.2.2)	Not to be less than	0,5	0,4	0,3	0,2
	Not to be less than	$L_H/17$	$L_H/17$	$L_H/17$	$L_H/17$
	Need not be more than	1,41	1,41	0,75	0,4
Required downflooding height (by Annex A, 6.2.2)	Not to be less than	0,5	0,4	0,3	0,2
	Need not be more than	1,41	1,41	0,75	0,4
Recess size (6.3) <i>only if fully enclosed</i>	max % loss in GM_T	$250 F_R/L_H$	$550 F_R/L_H$	$1200 F_R/L_H$	—
Stability information (see 7.5)		As required by 7.5			
Safety signs (see 7.6 and 8)		As required by 7.6			
Rolling in waves (see 7.7 & 7.8)	catamarans, max GZ (m) >	1,85/BPF	1,3/BPF	0,7/BPF	—
	trimarans, max GZ (m) >	2,9/BPF	2,2/BPF	1,5/BPF	—
Pitchpoling (see 7.7 & 7.9)	longitudinal RM area (kN·m·rad) >	20/BPF	7/BPF	2/BPF	—
Diagonal stability (see 7.10)	transverse righting moment 1° heel (bow + stern) (N·m) >	greater of 5 000 and $1,1 \cdot m_{MO}$	1 500	—	—
Habitable boats (see 7.11)		If vulnerable to inversion (see 7.11.2 & 7.11.3), apply 7.12 and 7.13:			
Buoyancy when inverted (see 7.12)		Volume of buoyancy (m^3) $V_B > m_{LDC}/850$			
Escape after inversion (see 7.13)		As required by 7.13			
Detection & removal of water (6.11)		As required by 6.11			

Annex J (informative)

Worksheets

The following worksheets are provided to assist in the systematic assessment of a boat according to this part of ISO 12217.

**ISO 12217-2 SAILING BOATS OF LENGTH GREATER THAN OR EQUAL TO 6 m
CALCULATION WORKSHEET No. 1**

Design:

Design category intended:		Monohull / multihull:			
Item	Symbol	Unit	Value	Ref.	
<u>Length of hull</u> as in ISO 8666	L_H	m		3.4.1	
<u>Length waterline</u>	L_{WL}	m			
<u>Empty craft condition mass</u>	m_{EC}	kg		3.5.1	
standard equipment		kg		3.6.12	
water ballast in tanks which are notified in the owner's manual to be filled whenever the boat is afloat		kg		3.5.2	
<u>Light craft condition mass</u> = m_{EC} + standard equipment + ballast	m_{LC}	kg		3.5.2	
Mass of:					
Desired Crew Limit	CL	—		3.6.3	
Mass of:					
desired Crew Limit at 75 kg each		kg		3.5.4	
provisions + personal effects		kg		3.5.4	
drinking water		kg		3.5.4	
fuel		kg		3.5.4	
lubricating and hydraulic oils		kg		3.5.4	
black water		kg		3.5.4	
grey water		kg		3.5.4	
any other fluids carried aboard (e.g. in bait tanks)		kg		3.5.4	
stores, spare gear and cargo (if any)		kg		3.5.4	
optional equipment and fittings not included in basic outfit		kg		3.5.4	
inflatable liferaft(s) in excess of essential safety equipment		kg		3.5.4	
other small boats carried aboard		kg		3.5.4	
margin for future additions		kg		3.5.4	
<u>Maximum load</u> = sum of above masses	m_L	kg		3.5.4	
<u>Maximum load condition mass</u> = $m_{LC} + m_L$	m_{LDC}	kg		3.5.5	
mass to be removed for Loaded Arrival Condition		kg		3.5.6	
<u>Loaded arrival condition mass</u>	m_{LA}	kg		3.5.6	
Mass of:					
minimum number of crew according to 3.5.3		kg		3.5.3	
non-consumable stores and equipment normally aboard		kg		3.5.3	
inflatable liferaft		kg		3.5.3	
Load to be included in minimum operating condition	m'_L	kg		3.5.3	
<u>Light craft condition mass</u>	m_{LC}	kg		3.5.2	
<u>Mass in the minimum operating condition</u> = $m_{LC} + m'_L$	m_{MO}	kg		3.5.3	
Is boat sail or non-sail?				3.1.2	
reference sail area according to ISO 8666	A_s	m ²		3.4.8	
sail area / displacement ratio = $A_s / (m_{LDC})^{2/3}$		—		3.1.2	
CLASSIFIED AS [non-sail if $A_s / (m_{LDC})^{2/3} < 0,07$]	SAIL/NON-SAIL?			3.1.2	
NB: If SAIL, continue using these worksheets, if NON-SAIL, use ISO 12217-1					
GO TO WORKSHEET No. 2					

ISO 12217-2 CALCULATION WORKSHEET No. 2

TESTS TO BE APPLIED

Question			Answer	Ref.
Is boat fully enclosed? (see definition in ref.)			YES/NO?	3.1.8
Is boat a catamaran or trimaran?			YES/NO?	3.1.3 and 3.1.4
If NO, choose from options 1 to 7. If YES, then:				
Length of hull	L_H	m		3.4.1
Beam between centres of buoyancy of sidehulls	B_{CB}	m		3.4.5
Is ratio $L_H/B_{CB} > 5$?			YES/NO?	7.1
If YES, treat the boat as a monohull, and choose from options 1 to 7. If NO, use option 8				
Mass in the minimum operating condition	m_{MO}	kg		3.5.3
Mass in the loaded arrival condition	m_{LA}	kg		3.5.6

Choose any ONE of the following options, and use the worksheets indicated for that option.

Option	All boats except catamarans and trimarans with $L_H/B_{CB} > 5$							Cats./tris.
	1	2	3	4	5	6	7	8
categories possible	A + B	C + D	C + D	C + D	C + D	C + D	C + D	A – D
decking or covering	fully enclosed ^a	fully enclosed ^a	all boats except fully encl'sd ^b	all boats except fully encl'sd ^b	all boats	all boats	all boats except fully encl'sd ^b	see note e
downflooding openings	3	3	3	3	3	3		3
downflooding angle	3	3						
downflooding height test	all boats	3	3	3	3			3
	full method	4	4	4	4			4
recess size	5 ^b				5 ^c	5 ^c		5 ^c
minimum energy	6	6						
angle of vanishing stability	6	6						
stability index	7	7						
knockdown-recovery test			8	8				
wind stiffness test					9	9		
flotation requirement				10		10		10 ^d
capsize recovery test							11	
bare poles speed								12
wind speed limits								13
stability requirements								14
habitable multihulls								14 ^d
detection & removal of water	15	15	15	15	15	15	15	15
SUMMARY	16	16	16	16	16	16	16	16

^a This term is defined in 3.1.8.
^b Only applicable to boats using 6.5.2 and having $\phi_v < 90^\circ$.
^c Only applicable to boats of design categories A, B or C that are fully enclosed.
^d Only applicable if boat is defined as habitable according to 3.1.9, and is deemed to be vulnerable to inversion when used in design category – see 7.11.2 & 7.11.3.
^e Fully enclosed if category A or B, otherwise any amount.

Option selected	
------------------------	--

ISO 12217-2 CALCULATION WORKSHEET No. 3

DOWNFLOODING

Downflooding openings:

Question	Answer	Ref.
Have all appropriate downflooding openings been identified?	YES/NO	6.2.1
Do all closing appliances satisfy ISO 12216?	YES/NO	6.2.1.1
Hatches or opening type windows are not fitted below minimum height above waterline?	YES/NO	6.2.1.2
Do seacocks comply with requirements?	YES/NO	6.2.1.3
Have potential downflooding openings within the boat been identified?	YES/NO	6.2.1.4
Are all openings fitted with closing appliances? (except openings for ventilation and engine combustion)	YES/NO	6.2.1.5
Categories possible: A or B if all are YES, C or D if first three are YES		6.2.1

Downflooding angle:

Item	Symbol	Unit	Value	Ref.
Required value:				6.2.3
Cats. A + B = 40°, Cat. C = 35°, Cat. D = 30°	$\phi_{D(R)}$	degrees		Table 3
Actual downflooding angle: any opening at m_{MO}	ϕ_D	degrees		3.3.2
Actual downflooding angle: any opening at m_{LA}	ϕ_D	degrees		3.3.2
Method used to determine ϕ_D :				Annex B
Category possible on downflooding angle ϕ_D :				6.2.3
Actual downflooding angle: to non-quick-draining cockpit	ϕ_{DC}	degrees		3.3.2
Actual downflooding angle: to main hatchway	ϕ_{DH}	degrees		3.3.2

Downflooding height:

Requirement	Basic requirement	Reduced value for small openings
applicable to	options 1 to 6 and 8	options 1 to 6 and 8, but only if figures are used
ref.	6.2.2.2 a)	6.2.2.2 b)
Obtained from Figure 2 or Annex A?		= basic × 0,75
Maximum area of small openings ($50L_H^2$) (mm ²) =		
Required downflooding height $h_{D(R)}$	Fig. 2 / Annex A	Category A
	Fig. 2 / Annex A	Category B
	Fig. 2 / Annex A	Category C
	Fig. 2 / Annex A	Category D
Actual downflooding height h_D ref: 6.2.2.1		
Design category possible		
Overall design category possible on downflooding height = lowest of above		

ISO 12217-2 CALCULATION WORKSHEET No. 4

DOWNFLOODING HEIGHT

Calculation using Annex A assuming use of option

Item	Symbol	Unit	Opening 1	Opening 2	Opening 3	Opening 4
Position of openings:						
Least longitudinal distance from bow/stern	x	m				
Least transverse distance from gunwale	y	m				
$F_1 = \text{greater of } (1 - x/L_H) \text{ or } (1 - y/B_H) =$	F_1	—				
Size of openings:						
Total combined area of openings to top of any downflooding opening	a	mm ²				
Longitudinal distance of opening from tip of bow	x'_D	m				
Limiting value of $a = (30L_H)^2$		mm ²				
If $a \geq (30L_H)^2, F_2 = 1,0$ If $a < (30L_H)^2, F_2 = 1 + \frac{x'_D}{L_H} \left(\frac{\sqrt{a}}{75L_H} - 0,4 \right)$	F_2	—				
Size of recesses:						
Volume of recesses which are not quick-draining in accordance with ISO 11812	V_R	m ³				
Freeboard amidships (see 3.4.6)	F_M	m				
$k = V_R / (L_H B_H F_M)$	k	—				
If opening is not a recess, $F_3 = 1,0$ If recess is quick-draining, $F_3 = 0,7$ If recess is not quick-draining, $F_3 = (0,7 + k^{0,5})$	F_3	—				
Displacement:						
Loaded displacement volume (see 3.5.7)	V_D	m ³				
$B = B_H$ for monohulls, B_{WL} for multihulls	B	m				
$F_4 = [(10 V_D) / (L_H \times B^2)]^{1/3}$	F_4	—				
Flotation:						
For boats using option 3 or 4, $F_5 = 0,8$ For all other boats, $F_5 = 1,0$	F_5	—				
Required calc. height: $= F_1 F_2 F_3 F_4 F_5 L_H / 15$	$h_{D(R)}$	m				
Required downflooding height with limits applied (see Annex A, Table A.1)	Category A	$h_{D(R)}$	m			
	Category B	$h_{D(R)}$	m			
	Category C	$h_{D(R)}$	m			
	Category D	$h_{D(R)}$	m			
Measured downflooding height:	h_D	m				
Design category possible:						
lowest of above =						

ISO 12217-2 CALCULATION WORKSHEET No. 5

RECESS SIZE

NB: This sheet is to be completed for the loaded arrival condition.

Item	Symbol	Unit	Value		Ref.
			Recess 1	Recess 2	
Angle of vanishing stability > 90°?	YES/NO				6.3.1a)
Depth recess < 3% max breadth of the recess over >35% of periphery?	YES/NO				6.3.1b)
Bulwark height < B _H /8 and has ≥ 5% drainage area in the lowest 25%?	YES/NO				6.3.1c)
Drainage area per side (m ²) divided by recess volume (m ³)					6.3.1d)
Height position of drainage area (lowest 25% / lowest 50% / full depth)					6.3.1d)
Drainage area meets requirements 1) and 2)?	YES/NO				6.3.1d)
Recess exempt from size limit?	YES/NO				6.3.1
SIMPLIFIED METHOD: Use 1), 2) or 3) below.			Zone 1	Zone 2	
Requirement: from results below, design category possible =					6.3.2.1
Average freeboard to loaded waterline at aft end of recess	F _A	m			6.3.2.1
Average freeboard to loaded waterline at sides of recess	F _S	m			6.3.2.1
Average freeboard to loaded waterline at forward end of recess	F _F	m			6.3.2.1
Average freeboard to recess periphery = (F _A + 2F _S + F _F) / 4	F _R	m			6.3.2.1
Category A permitted percentage loss in metacentric height (GM _T) = 250 F _R /L _H					6.3.2.1
Category B permitted percentage loss in metacentric height (GM _T) = 550 F _R /L _H					6.3.2.1
Category C permitted percentage loss in metacentric height (GM _T) = 1 200 F _R /L _H					6.3.2.1
1) Loss of GM_T used?			YES/NO		6.3.2.2
second moment of area of free-surface of recess	SMA _{RECESS}	m ⁴			6.3.2.2
metacentric height of boat at m _{LA}	GM _T	m			6.3.2.2
Calculated percentage loss in metacentric height (GM _T) = $\frac{102\,500 \times SMA_{RECESS}}{m_{LA} \times GM_T}$					6.3.2.2
2) Second moment of areas used?			YES/NO		6.3.2.3
second moment of area of free-surface of recess	SMA _{RECESS}	m ⁴			6.3.2.3
second moment of area of waterplane of boat at m _{LA}	SMA _{WP}	m ⁴			6.3.2.3
Calculated percentage loss in metacentric height (GM _T) = $\left(\frac{220 \times SMA_{RECESS}}{SMA_{WP}} \right)$					6.3.2.3
3) Recess dimensions used?			YES/NO		6.3.2.4
maximum length of recess at the retention level (see 3.5.11)	l	m			6.3.2.4
maximum breadth of recess at the retention level (see 3.5.11)	b	m			6.3.2.4
Calculated percentage loss in metacentric height (GM _T) = $240 \left(\frac{l \times b^3}{L_H \times B_H^3} \right)^{0.7}$					6.3.2.4
DIRECT CALCULATION METHOD used?			YES/NO		6.3.3
percentage full of water = 60 – 240 F/L _H					6.3.3a)
actual residual righting moment up to φ _D , φ _V or 90° whichever is least		N·m			6.3.3b)
required residual righting moment up to φ _D , φ _V or 90° whichever is least		N·m			6.3.3b)
design category possible					
Design category achieved					

ISO 12217-2 CALCULATION WORKSHEET No. 6 MINIMUM RIGHTING ENERGY & ANGLE OF VANISHING STABILITY

Minimum righting energy:

in minimum operating condition

Item	Symbol	Unit	At m_{MO}	Ref.
Mass in minimum operating condition	m_{MO}	kg		3.5.3
Area under GZ curve up to ϕ_V in minimum operating condition	A_{GZ}	m·deg		6.4
Righting energy up to $\phi_V = m_{MO} \cdot A_{GZ}$	E_{GZ}	kg·m·deg		6.4
Requirement: for design category A: $E_{GZ} \geq 172\,000$; for design category B: $E_{GZ} \geq 57\,000$.				Table 4
Design category possible on minimum energy:				

Angle of vanishing stability:

complete both columns

Item	Symbol	Unit	At m_{MO}	At m_{LA}	Ref.
Required value of angle of vanishing stability:					6.5
Design category A = $(130 - m/500)$ but $\geq 100^\circ$ Design category B = $(130 - m/200)$ but $\geq 95^\circ$ Design category C = 90° Design category D = 75°	$\phi_{V(R)}$	degree			Table 5
Actual angle of vanishing stability:	ϕ_V	degree			3.4.10
Design category possible on angle of vanishing stability:					6.5.1

Alternative for design category B only:

Item	Symbol	Unit	At m_{MO}	At m_{LA}	Ref.
Mass of boat in each condition	m_{MO} OR m_{LA}	kg			3.5.3 or 3.5.6
Required value of $\phi_V = (130 - 0,005m)$ but always $\geq 75^\circ$		degree			6.5.2a)
Actual angle of vanishing stability:	ϕ_V	degree			3.4.11
Required value of ϕ_V	$\phi_{V(R)}$	degree			6.5.2a)
Is required value of ϕ_V attained?		YES/NO			6.5.2a)
Volume of buoyancy calculated according to Annex D	V_B	m ³			Annex D
Mass of boat in maximum load condition	m_{LDC}	kg			3.5.5
Is $V_B > (m_{LDC}/850)$?		YES/NO			6.5.2b)
Are accesses to non-habitable compartments fitted with hatches or doors watertight to degree 2 and marked "Keep shut when under way"?		YES/NO			6.5.2c)
Do flotation elements (where fitted) comply with Annex E?		YES/NO			6.5.2d)
Is stability information required by 6.5.2e) supplied?		YES/NO			6.5.2e)
Are safety signs according to Figure 3 displayed?		YES/NO			6.5.2f)
Can boat be assigned design category B? If all answers are YES		YES/NO			6.5.2

ISO 12217-2 CALCULATION WORKSHEET No. 7

STABILITY INDEX

Stability index (STIX):

complete both columns

Factor	Item	Symbol	Unit	At m_{MO}	At m_{LA}	Ref.
FDS (6.6.2)	Positive area under GZ curve to ϕ_V	A_{GZ}	m deg.			6.6.2
	Length of hull	L_H	m			3.4.1
	Factor as calculated = $[A_{GZ}/(15,81 L_H^{0,5})]^{0,3}$	FDS	—			6.6.2
	FDS when limited to the range 0,5 to 1,5	FDS	—			6.6.2
FIR (6.6.3)	Angle of vanishing stability	ϕ_V	degree			3.4.10
	If $m < 40,000$, FIR = $\phi_V/(125 - m/1\ 600)$ If $m \geq 40,000$, FIR = $\phi_V/100$	FIR	—			6.6.3
	FIR when limited to the range 0,4 to 1,5	FIR	—			6.6.3
FKR (6.6.4)	Righting lever at 90° heel	GZ_{90}	m			6.6.4
	Reference sail area (see ISO 8666)	A_S	m ²			3.4.8
	Height of centre of area of A_S above waterline	h_{CE}	m			6.6.4
	Calculate $F_R = (GZ_{90} m)/(2 A_S h_{CE})$	F_R	—			6.6.4
	If $F_R \geq 1,5$, FKR = $(0,875 + 0,0833 F_R)$ If $F_R < 1,5$, FKR = $(0,5 + 0,333 F_R)$ If $\phi_V < 90^\circ$, FKR = 0,5	FKR	—			6.6.4
	FKR when limited to the range 0,5 to 1,5	FKR	—			6.6.4
FDL (6.6.5)	Length waterline	L_{WL}	m			3.4.2
	Length base size $L_{BS} = (2 L_{WL} + L_H)/3$	L_{BS}	m			6.6.5
	Calculate $F_L = (L_{BS}/11)^{0,2}$	F_L	—			6.6.5
	Calculate $FDL = \left\{ 0,6 + \left[\frac{15 m_{MO} F_L}{L_{BS}^3 (333 - 8 L_{BS})} \right] \right\}^{0,5}$	FDL	—			6.6.5
	FDL when limited to the range 0,75 to 1,25	FDL	—			6.6.5
FBD (6.6.6)	Beam of hull	B_H	m			3.4.3
	Beam waterline	B_{WL}	m			3.4.4
	Calculate $F_B = 3,3 B_H / (0,03 m)^{1/3}$	F_B	—			6.6.6
	If $F_B > 2,20$ FBD = $[13,31 B_{WL}/(B_H F_B^3)]^{0,5}$ If $F_B < 1,45$ FBD = $[B_{WL} F_B^2 / (1,682 B_H)]^{0,5}$ Otherwise FBD = $1,118 (B_{WL}/B_H)^{0,5}$	FBD	—			6.6.6
	FBD when limited to the range 0,75 to 1,25	FBD	—			6.6.6
FWM (6.6.7)	Downflooding angle = lesser of ϕ_{DC} and ϕ_{DH}	ϕ_D	degree			3.3.2
	If $\phi_D \geq 90^\circ$ (see worksheet 3) then FWM = 1,0 If ϕ_D is less than 90° then:					
	Righting lever at downflooding angle	GZ_D	m			6.6.7
	Lever from centre of sail area to underwater profile	$h_{CE} + h_{LP}$	m			6.6.7
	Calc. wind speed at which serious flooding occurs = $\{13 m_{MO} GZ_D / [A_S (h_{CE} + h_{LP}) \cos \phi_D ^{1,3}]\}^{0,5}$	v_{AW}	m/s			6.6.7
	If $\phi_{DW} < 90^\circ$, FWM = $v_{AW}/17$; if $\phi_{DW} \geq 90^\circ$, FWM = 1,0	FWM	—			6.6.7
	FWM when limited to the range 0,5 to 1,0	FWM	—			6.6.7

ISO 12217-2 CALCULATION WORKSHEET No. 7 (continued)

STABILITY INDEX

complete both columns

Factor	Item	Symbol	Unit	At m_{MO}	At m_{LA}	Ref.
FDF (6.6.8)	Downflooding angle to non-quick-draining cockpit	ϕ_{DC}	degree			3.3.2
	Downflooding angle to main access hatch	ϕ_{DH}	degree			3.3.2
	Total area of openings for finding $\phi_{DA} = (1,2 L_H B_H F_M)$		cm ²			6.6.8
	Downflooding angle at which above area is immersed	ϕ_{DA}	degree			6.6.8
	Angle of vanishing stability	ϕ_V	degree			3.4.11
	Least of the above four angles	ϕ_{DF}	degree			6.6.8
	Then FDF = $\phi_{DF}/90$					6.6.8
	FDF when limited to the range 0,5 to 1,25	FDF ₁	—			6.6.8
	Does boat float according to 7.6 and also when flooded have GZ ₉₀ > 0?			YES/NO		6.6.8
	If YES, calculate final FDF = 1,2·FDF ₁ , otherwise FDF = FDF ₁					6.6.8

NB: Final value to be used for each factor is the figure in the shaded box.

Calculation of STIX, and assignment of design category:

Item	Symbol	Unit	At m_{MO}	At m_{LDC}	Ref.
Length base size L_{BS} (from Worksheet 5) = $(2 L_{WL} + L_H)/3$	L_{BS}	m			6.6.9
Product of all 7 factors = FDS · FIR · FKR · FDL · FBD · FWM · FDF	F	—			6.6.9
STIX = $[(7 + 2,25 L_{BS}) \cdot F^{0,5}]$	STIX	—			6.6.9
Design category possible on STIX: A when STIX > 32, B when STIX > 23, C when STIX > 14, D when STIX > 5					Table 6

ISO 12217-2 CALCULATION WORKSHEET No. 8 KNOCKDOWN-RECOVERY TEST

Design categories C and D only

Item	Symbol	Cat. C	Cat. D	Ref.
Experimental method: Crew Limit	CL			3.6.3
Is boat prepared and persons positioned as in 6.7.2?	YES/NO			6.7.2
Is water or other weight used instead of persons, if so which?				6.7.2
Masthead taken to		waterline	horizontal	6.7.3, 6.7.4
Masthead held in position for		60 s	10 s	6.7.3, 6.7.4
Boat recovers when released?	YES/NO			6.7.3, 6.7.4
Boat floats so it can be pumped or bailed out?	YES/NO			6.7.3, 6.7.4
If boat achieves YES to each of above, design category is OK				
Alternative theoretical method: Is GZ positive at heel angle defined above?	YES/NO			6.7.5
Design category given:				

ISO 12217-2 CALCULATION WORKSHEET No. 9

WIND STIFFNESS TEST

Design categories C and D only

Experimental method:

Item	Symbol	Unit	Unreefed	Reefed	Ref.
Boat prepared and weight positioned as in 6.8.2?		YES/NO			6.8.2.1
Final tension in pull-down line	T	kg			6.8.2.3
Perpendicular lever between pull-down and mooring lines	h	m			6.8.2.3 Figure 5
Final angle of heel observed	ϕ_T	degree			6.8.2.3
Beam of hull	B_H	m			3.4.3
Actual profile projected area of sails, including overlaps	A'_S	m ²			3.4.9
Upright lever from centre of sail area to underwater profile	$h'_{CE} + h_{LP}$	m			6.8.2.4 Figure 6
Calculated wind speed = $\sqrt{\frac{13hT + 390B_H}{A'_S (h'_{CE} + h_{LP}) (\cos \phi_T)^{1.3}}}$	v_W	m/s			6.8.2.4
Is reefed sail plan used?	YES/NO				6.8.4.2
Design category given according to Table 7.					Table 7

NB: Safety signs in accordance with Figure 7 must be affixed to the boat.

Alternative theoretical method:

Item	Symbol	Unit	Unreefed	Reefed	Ref.
Righting moment curve increased by one crew to windward		YES/NO?			6.8.3.2
Option (from Worksheet 2) being used					Table 2
Design Category intended					
Relevant calculation wind speed taken from Table 6	v_W	m/s			Table 6
Actual profile projected area of sails, including overlaps	A'_S	m ²			3.4.9
Upright lever from centre of sail area to underwater profile	$h'_{CE} + h_{LP}$	m			6.8.2.4 Figure 6
Calculate: $0,75 v_W^2 A'_S (h'_{CE} + h_{LP})$	M_{W0}	N·m			6.8.3.3
From righting moment curve and wind heeling curve [= $M_{W0} (\cos \phi)^{1.3}$] resulting angle of heel =	ϕ	degree			6.8.3.4
Is $\phi < \phi_D$ (see Worksheet 3) and $< 45^\circ$?		YES/NO?			6.8.3.4
Is reefed sail plan used?		YES/NO?			6.8.4.2
If YES, Design Category given:					

NB: Safety signs in accordance with Figure 7 must be affixed to the boat.

ISO 12217-2 CALCULATION WORKSHEET No. 10

FLOTATION REQUIREMENT

Annex D

Objective: to show that the buoyancy available from the hull structure, fittings and flotation elements equals or exceeds that required to support the loaded boat.

Item	Mass kg	Density kg/m ³	Volume m ³ = mass/density	Ref.
Hull structure:				
GRP laminate		1 500		Table D.1
Foam core materials				Table D.1
Balsa core materials		150		Table D.1
Plywood		600		Table D.1
Other timber (type =)				Table D.1
Permanent ballast (type =)				Table D.1
Fastenings and other metalwork (type =)				Table D.1
Windows (glass/plastic)				Table D.1
Engines and other fittings and equipment:				
Diesel engine(s)		5 000		Table D.1
Petrol engine(s)		4 000		Table D.1
Outboard engine(s)		3 000		Table D.1
Sail-drive or stern-drive strut(s)		3 000		Table D.1
Mast(s) and spar(s) (material = alloy/spruce)				Table D.1
Stowed sails and ropes		1 200		Table D.1
Food and other stores		2 000		Table D.1
Miscellaneous equipment		2 000		Table D.1
Non-integral fuel tank(s) (material =)				Table D.1
Non-integral water tank(s) (material =)				Table D.1
Gross volumes of fixed tanks and air containers:				
Fuel tank(s)				D.2.2
Water tank(s)				D.2.2
Other tank(s)				D.2.2
Air tanks or containers meeting the requirements of Annex E				D.2.2
Total volume of hull, fittings and equipment, V_B = sum of all above volumes				D.2.2
Mass in maximum load condition	m_{LDC}	kg		3.5.5
calculate ratio $m_{LDC}/V_B =$				D.2.3
For options 4 and 6, $m_{LDC}/V_B < 850?$				YES/NO D.2.3

ISO 12217-2 CALCULATION WORKSHEET No. 11

CAPSIZE-RECOVERY TEST

Design categories C and D only

Objective: to demonstrate that a boat can be returned to the upright after a capsize by the actions of the crew using their body action and/or righting devices purposely designed and permanently fitted to the boat, that it will subsequently float, and to verify that the recommended minimum crew mass is sufficient for the recovery method used.

Item	Unit	Value	Ref.
Minimum number of crew required	—		6.10.7
Minimum mass of crew required	kg		6.10.7
Is boat prepared as in 6.10.2 to 6.10.5?	YES/NO		6.10.2 to 6.10.5
Does boat float for > 5 min when fully capsized?	YES/NO		6.10.6
Time required to right the boat (least time of 1 to 3 attempts)	minutes		6.10.8
Is this time less than 5 min?	YES/NO		6.10.8
With one 75 kg person aboard, boat floats so it can be pumped or bailed out?	YES/NO		6.10.10
With full Crew Limit aboard, without bailing, boat floats approx. level with at least 2/3 periphery showing, for more than 5 min?	YES/NO		6.10.11
INFORMATION FOR OWNER'S MANUAL:			
Likelihood of capsize occurring in normal use:			
Righting technique which is most successful:			
Minimum number of crew required:	Minimum mass of crew required:		kg
Design category recommended by the builder:			

ISO 12217-2 CALCULATION WORKSHEET No. 12

BARE POLES FACTOR

Boat is a catamaran/trimaran: Intended design category: Refer to 7.7

Item	Transverse		Longitudinal	
Limiting moment	LM _T (kN·m) =		LM _L (kN·m) =	
Hull	area (m ²) =		area (m ²) =	
	lever (m) =		lever (m) =	
	moment (m ³)	area × lever =	moment (m ³)	area × lever =
Mast No. 1	area (m ²) =		area (m ²) =	
	lever (m) =		lever (m) =	
	moment (m ³)	area × lever =	moment (m ³)	area × lever =
Boom No. 1	area (m ²) =		area (m ²) =	
	lever (m) =		lever (m) =	
	moment (m ³)	area × lever =	moment (m ³)	area × lever =
Mast No. 2	area (m ²) =		area (m ²) =	
	lever (m) =		lever (m) =	
	moment (m ³)	area × lever =	moment (m ³)	area × lever =
Boom No. 2	area (m ²) =		area (m ²) =	
	lever (m) =		lever (m) =	
	moment (m ³)	area × lever =	moment (m ³)	area × lever =
Antennae with area greater than 0,01m ²	area (m ²) =		area (m ²) =	
	lever (m) =		lever (m) =	
	moment (m ³)	area × lever =	moment (m ³)	area × lever =
Standing rigging	area (m ²) =		area (m ²) =	
	lever (m) =		lever (m) =	
	moment (m ³)	area × lever =	moment (m ³)	area × lever =
Total hull & rig moments of area Σ(A_H·h_H) =			Total hull/rig mom't of area =	
Sail stowed on boom No. 1	area (m ²) =		area (m ²) =	
	lever (m) =		lever (m) =	
	moment (m ³)	area × lever =	moment (m ³)	area × lever =
Roller furled sail No. 1 (excluding in-mast furling)	area (m ²) =		area (m ²) =	
	lever (m) =		lever (m) =	
	moment (m ³)	area × lever =	moment (m ³)	area × lever =
Roller furled sail No. 2 (excluding in-mast furling)	area (m ²) =		area (m ²) =	
	lever (m) =		lever (m) =	
	moment (m ³)	area × lever =	moment (m ³)	area × lever =
Total bare poles moment of area Σ(A_{BP}·h_{BP}) =			Total bare poles mom't area =	
Wing mast	area (m ²) =		area (m ²) =	
	lever (m) =		lever (m) =	
	moment (m ³)	Σ(A _{WM} ·h _{WM}) =	moment (m ³)	Σ(A _{WM} ·h _{WM}) =
Bare Poles speed, v _{BP} = 1,85 √ [LM _T / (0,8Σ(A _H ·h _H) + Σ(A _{WM} ·h _{WM}))]			1,85 √ [LM _L / (0,8Σ(A _H ·h _H) + Σ(A _{WM} ·h _{WM}))]	
Lesser value of v_{BP} in roll and pitch =				

ISO 12217-2 CALCULATION WORKSHEET No. 13

WIND SPEED LIMITS

This work sheet is to be used as many times as necessary to cover the range of probable sail combinations.

Boat is a catamaran/trimaran: Intended design category: Refer to 7.5

Item	Transverse		Longitudinal	
Limiting moment	LM _T (kN·m) =		LM _L (kN·m) =	
Total hull & rig moments of area Σ(A _H ·h _H) =			Total hull/rig mom't of area =	
Sail No. 1	area (m ²) =		area (m ²) =	
	lever (m) =		lever (m) =	
	moment (m ³)	area × lever =	moment (m ³)	area × lever =
Sail No. 2	area (m ²) =		area (m ²) =	
	lever (m) =		lever (m) =	
	moment (m ³)	area × lever =	moment (m ³)	area × lever =
Sail No. 3	area (m ²) =		area (m ²) =	
	lever (m) =		lever (m) =	
	moment (m ³)	area × lever =	moment (m ³)	area × lever =
Sail No. 4	area (m ²) =		area (m ²) =	
	lever (m) =		lever (m) =	
	moment (m ³)	area × lever =	moment (m ³)	area × lever =
Sail stowed on boom	area (m ²) =		area (m ²) =	
	lever (m) =		lever (m) =	
	moment (m ³)	area × lever =	moment (m ³)	area × lever =
Sail stowed on boom	area (m ²) =		area (m ²) =	
	lever (m) =		lever (m) =	
	moment (m ³)	area × lever =	moment (m ³)	area × lever =
Roller furled sail	area (m ²) =		area (m ²) =	
	lever (m) =		lever (m) =	
	moment (m ³)	area × lever =	moment (m ³)	area × lever =
Roller furled sail	area (m ²) =		area (m ²) =	
	lever (m) =		lever (m) =	
	moment (m ³)	area × lever =	moment (m ³)	area × lever =
Total sail moments of area Σ(A _S ·h _S) =			Total sail moment of area =	
Wind speed limit, v _W = 1,85 √ $\frac{LM_T}{0,8\Sigma(A_H \cdot h_H) + \Sigma(A_S \cdot h_S)}$			1,85 √ $\frac{LM_L}{0,8\Sigma(A_H \cdot h_H) + \Sigma(A_S \cdot h_S)}$	
Lesser value of v _W in roll and pitch =				

NB: Where a boat is fitted with a wing mast, it shall be treated as a sail.

ISO 12217-2 CALCULATION WORKSHEET No. 14 STABILITY REQUIREMENTS

Boat is a catamaran/trimaran: Intended design category:

Item	Symbol	Unit	Value			Ref.
			Cat. A	Cat. B	Cat. C	
Bare poles factor						
Bare poles wind speed (see worksheet 12)	v_{BP}	knots				7.7
Bare poles factor = $\left(\frac{v_{BP}}{70}\right)^{0,4}$ where $v_{BP} < 70$ = 1,0 where $v_{BP} \geq 70$	BPF	—				7.7b)
Rolling in breaking waves						
Required maximum transverse righting lever	GZ	m				Table 8
Actual maximum transverse righting lever		m				
Design category possible for rolling in breaking waves?		YES/NO				7.8
Ratio (actual) / (required)						7.11.2-.3
Does ratio exceed that for "not vulnerable to inversion"? (1,35 for catamarans, 1,80 for trimarans)		YES/NO				7.11.2-.3
Pitchpoling						
Required minimum longitudinal righting moment area		kN·m·rad				Table 9
Actual minimum longitudinal righting moment area		kN·m·rad				
Design category possible on pitchpoling?		YES/NO				7.9
Ratio (actual) / (required)						7.11.2-.3
Does ratio exceed that for "not vulnerable to inversion"? (1,35 for catamarans, 1,80 for trimarans)		YES/NO				7.11.2-.3
Diagonal stability						
Required transverse righting moment for 1° heel		kg·m		1 500	n/a	7.10
Bow-down actual transverse righting moment for 1° heel		kg·m			n/a	7.10
Stern-down actual transverse righting moment for 1° heel		kg·m			n/a	7.10
Design category possible on diagonal stability?		YES/NO			n/a	7.10
Design cat. possible: rolling, pitchpoling & diag. stability?		YES/NO				

Habitable boats

Habitable boats	Answer	Ref.
Is boat habitable?	YES/NO	3.1.9
Is boat vulnerable to inversion when used in design category?	YES/NO	7.11.2-.3
Clause(s) of standard that apply ref. vulnerability to inversion		7.11.2-.3
If both the above responses are YES, then:		
Does boat comply with inverted buoyancy requirements? (see worksheet 10)	YES/NO	7.12
Does boat comply with viable means of escape requirements?	YES/NO	7.13

ISO 12217-2 CALCULATION WORKSHEET No. 15

DETECTION
+ REMOVAL OF WATER

Item	Unit	Response	Ref.
The internal arrangement facilitates the drainage of water to bilge suction point(s), to a location from which it may be bailed rapidly, or directly overboard?	YES/NO		6.11.1
Is boat provided with means of removing water from the bilges in accordance with ISO 15083?	YES/NO		6.11.2
Table 2 option used for assessment:			6.11.3
Can water in boat be detected from helm position?	YES/NO		6.11.3
Method(s) used:	direct visual inspection		6.11.3
	transparent inspection panels		6.11.3
	bilge alarms		6.11.3
	indication of the operation of automatic bilge pumps		6.11.3
	other means (specify):		6.11.3

ISO 12217-2 CALCULATION WORKSHEET No. 16

SUMMARY

Design description:		
Design category intended:	Crew limit:	Date:

Sheet	Item	Symbol	Unit	Value	
	Length of hull: (as in ISO 8666)	L_H	m		
	Length waterline	L_{WL}	m		
1	Mass:				
	Empty craft condition mass	m_{EC}	kg		
	Light craft condition mass	m_{LC}	kg		
	Maximum load	m_L	kg		
	Maximum load condition mass = $m_{LC} + m_L$	m_{LDC}	kg		
	Loaded arrival condition mass	m_{LA}	kg		
	Minimum operating condition mass	m_{MO}	kg		
	1	Is boat sail or non-sail?	SAIL / NON-SAIL		
2	Option selected:				
3	Downflooding openings: are all requirements met?	Unit	Required	Actual	Pass/Fail
	Downflooding angle: to any opening, ϕ_{DA}	degree	>		
	to non-quick-draining cockpit, ϕ_{DC}	degree			
	to main access hatchway, ϕ_{DH}	degree			
3 and 4	Downflooding height: Worksheet employed for basic height				
	basic requirement	m	\geq		
	reduced height for small openings (sheet 3 only)	m	\geq		
5	Recess size: (Options 2 (6.5.2), 5, 6 & 8 except Cat D)				
	Simplified method: max reduction in GM_T	%	\leq		
	Direct calculation: margin righting over heeling moment	N-m	\geq		
6	Minimum righting energy	kg·m·deg	\geq		
6	Angle of vanishing stability: (options 1 + 2 only) $\phi_V =$	degree	>		
7	Stability index: (options 1 + 2 only) $STIX =$	—	>		
8	Knockdown-recovery test: (options 3 + 4 only)	PASS/FAIL			
	method used = experimental or theoretical?				
	Design category =				
9	Wind stiffness test: (options 5 + 6 only) $v_{W} =$	m/s	>		
	Design category =				
	was reefed sail area used? (i.e. are warning labels required?)	YES/NO			
10	Flotation requirement: ratio $m_{LDC}/V_B =$ (options 4, 6 + 8 only)	kg/m ³	<		
11	Capsize recovery test: (option 7 only) are all requirements met?	YES/NO			
	Design category recommended by the builder				
12 + 13	Stability information: (option 8 only) info. supplied like Table F.1?	YES/NO			

ISO 12217-2 CALCULATION WORKSHEET No. 16 (continued)

SUMMARY

Sheet	Item	Unit	Required	Actual	Pass/Fail	
14	Rolling in breaking waves maximum transverse righting lever	m	≥			
	Pitchpoling longitudinal righting moment area	kN·m·rad	≥			
	Diagonal stability: transverse righting moment for 1° heel	bow down	kg·m	≥		
		stern down	kg·m	≥		
14	Habitable boats					
	Is boat habitable?				YES/NO	
	Is boat vulnerable to inversion when used in design category?				YES/NO	
	If both the above responses are YES, then:					
	Does boat comply with inverted buoyancy requirements?				YES/NO	
	Does boat comply with viable means of escape requirements?				YES/NO	
15	Detection and removal of water are all requirements satisfied?					
NB: Boat must pass all requirements applicable to option to be given intended design category.						
Design category given:			Assessed by:			

Bibliography

- [1] ISO 6185 (all parts), *Inflatable boats*
- [2] *Principles of Naval Architecture*, published by the Society of Naval Architects and Marine Engineers in the USA.
- [3] ASTM F1321-92, *Guide for Conducting a Stability Test (Lightweight Survey and Inclining Experiment) to Determine the Light Ship Displacement and Centers of Gravity of a Vessel*
- [4] ISO 12215-7:—¹⁾, *Small craft — Hull construction and scantlings — Part 7: Scantling determination of multihulls*
- [5] IMO Resolution MSC.81(70), *Revised Recommendation on Testing of Life-Saving Appliances*

1) Under preparation.

ICS 47.080

Price based on 86 pages