**Petroleum, petrochemical and natural gas
industries — Hairpin-type heat
exchangers**

*Industries du pétrole et du gaz naturel — Échangeurs thermiques en
épingle à cheveux*





COPYRIGHT PROTECTED DOCUMENT

© ISO 2012

All rights reserved. Unless otherwise specified, no part of this publication may be reproduced or utilized in any form or by any means, electronic or mechanical, including photocopying and microfilm, without permission in writing from either ISO at the address below or ISO's member body in the country of the requester.

ISO copyright office
Case postale 56 • CH-1211 Geneva 20
Tel. + 41 22 749 01 11
Fax + 41 22 749 09 47
E-mail copyright@iso.org
Web www.iso.org

Published in Switzerland

Contents

Page

Foreword	v
Introduction.....	vi
1 Scope	1
2 Normative reference.....	1
3 Terms and definitions	1
4 General	3
5 Proposal information required.....	4
6 Drawings and other required data	4
6.1 Outline drawings and other supporting data.....	4
6.2 Information required after outline drawings are reviewed.....	5
6.3 Reports and records	6
7 Design.....	7
7.1 Design temperature.....	7
7.2 Design pressure	7
7.3 Cyclic design	7
7.4 Shell	8
7.5 Front closure.....	8
7.6 Rear closure.....	10
7.7 Tube bundle	11
7.8 Nozzles and other connections	14
7.9 Shell supports.....	18
7.10 Gaskets.....	19
7.11 Flanged external girth joints	19
7.12 Cladding for corrosion allowance	19
8 Materials	20
8.1 General	20
8.2 Requirements for carbon steel in sour or wet hydrogen sulfide service	20
8.3 Gaskets.....	20
8.4 Tubes	20
9 Fabrication	21
9.1 Shells	21
9.2 Tubes	21
9.3 Welding.....	21
9.4 Heat treatment	22
9.5 Dimensional tolerances	22
9.6 Gasket contact surfaces other than nozzle flange facings.....	23
9.7 Tube-to-tubesheet joints.....	23
9.8 Assembly.....	24
10 Inspection and testing	24
10.1 Quality assurance.....	24
10.2 Quality control	24
10.3 Pressure testing	26
10.4 Nameplates and stampings	26
11 Preparation for shipment.....	27
11.1 Protection	27
11.2 Identification	27

12	Supplemental requirements	28
12.1	General	28
12.2	Design	28
12.3	Examination	28
Annex A	(informative) Recommended practices	30
Annex B	(informative) Hairpin heat exchanger checklist	32
Annex C	(informative) Hairpin heat exchanger data sheets	34
Bibliography	45

Foreword

ISO (the International Organization for Standardization) is a worldwide federation of national standards bodies (ISO member bodies). The work of preparing International Standards is normally carried out through ISO technical committees. Each member body interested in a subject for which a technical committee has been established has the right to be represented on that committee. International organizations, governmental and non-governmental, in liaison with ISO, also take part in the work. ISO collaborates closely with the International Electrotechnical Commission (IEC) on all matters of electrotechnical standardization.

International Standards are drafted in accordance with the rules given in the ISO/IEC Directives, Part 2.

The main task of technical committees is to prepare International Standards. Draft International Standards adopted by the technical committees are circulated to the member bodies for voting. Publication as an International Standard requires approval by at least 75 % of the member bodies casting a vote.

Attention is drawn to the possibility that some of the elements of this document may be the subject of patent rights. ISO shall not be held responsible for identifying any or all such patent rights.

ISO 12212 was prepared by Technical Committee ISO/TC 67, *Materials, equipment and offshore structures for petroleum, petrochemical and natural industries*, Subcommittee SC 6, *Processing equipment and systems*.

Introduction

It is necessary that users of this International Standard be aware that further or differing requirements can be needed for individual applications. This International Standard is not intended to inhibit a vendor from offering, or the purchaser from accepting, alternative equipment or engineering solutions for the individual application. This can be particularly applicable where there is an innovative or developing technology. Where an alternative is offered, it is the responsibility of the vendor to identify any variations from this International Standard and provide details.

This International Standard requires the purchaser to specify certain details and features.

A bullet (●) at the beginning of a clause or subclause indicates a requirement for the purchaser to make a decision or provide information (for information, a checklist is provided in Annex B).

In this International Standard, where practical, US Customary (USC) or other units are included in parentheses for information.

Petroleum, petrochemical and natural gas industries — Hairpin-type heat exchangers

1 Scope

This International Standard specifies requirements and gives recommendations for the mechanical design, materials selection, fabrication, inspection, testing and preparation for shipment of hairpin heat exchangers for use in the petroleum, petrochemical and natural gas industries.

Hairpin heat exchangers include double-pipe and multi-tube type heat exchangers.

2 Normative reference

The following referenced documents are indispensable for the application of this document. For dated references, only the edition cited applies. For undated references, the latest edition of the referenced document (including any amendments) applies.

ISO 15156 (all parts), *Petroleum and natural gas industries — Materials for use in H₂S-containing environments in oil and gas production*

ISO 23251, *Petroleum, petrochemical and natural gas industries — Pressure-relieving and depressuring systems*

ASME B16.5¹⁾, *Pipe Flanges and Flanged Fittings: NPS 1/2 through NPS 24 Metric/Inch Standard*

NACE MR0103²⁾, *Materials Resistant to Sulfide Stress Cracking in Corrosive Petroleum Refining Environments*

NACE SP0472, *Methods and Controls to Prevent In-Service Environmental Cracking of Carbon Steel Weldments in Corrosive Petroleum Refining Environments*

TEMA³⁾, *Standards of the Tubular Exchanger Manufacturers Association*

3 Terms and definitions

For the purposes of this document, the following terms and definitions apply.

3.1

cyclic service

process operation with periodic variation in temperature, pressure and/or flowrate

1) ASME International, 3 Park Avenue, New York, NY 10016-5990, USA.

2) NACE International, P.O. Box 218340, Houston, TX 77218-8340, USA.

3) Tubular Exchanger Manufacturers Association, 25 North Broadway, Tarrytown, NY 10591, USA.

- 3.2 double-pipe**
single pipe within a shell
- 3.3 effective heat transfer area**
outside surface area of the tubes that contributes to heat transfer including finned surface area (if any)
- 3.4 full-penetration weld**
welded joint that results in weld metal through the entire thickness of the components being joined
- 3.5 front closure**
closure that connects the tube side to purchaser's tube side piping and fixes the tube bundle or element to the shell
- 3.6 hairpin heat exchanger**
double-pipe (pipe-in-pipe) or multi-tube heat exchanger of two-leg bundle where each leg has its own separate shell
- NOTE Figure 1 shows typical components of a hairpin heat exchanger.
- 3.7 heat exchanger unit**
one or more heat exchangers arranged in series or parallel for a specified service that work together to perform the intended duty
- 3.8 hydrogen service**
service that contains hydrogen at a partial pressure exceeding 700 kPa (100 psi) absolute
- 3.9 item number**
purchaser's identification number for a hairpin heat exchanger
- 3.10 minimum design metal temperature**
lowest metal temperature at which pressure-containing elements can be subjected to design pressure
- EXAMPLES Ambient temperature or process fluid temperature.
- 3.11 multi-tube**
multiple tubes within a shell
- 3.12 pressure design code**
recognized pressure vessel standard specified or agreed by the purchaser
- EXAMPLES ASME BPVC, Section VIII; EN 13445 (all parts).
- 3.13 rear closure**
closure used at the return end of the heat exchanger which covers the u-bends
- 3.14 sealing ring**
special gasket that provides a seal on the OD of tubesheet and the shell/tube side flange

3.15**hairpin section**

one U-tube element with two shell legs

3.16**seal-welded**

tube-to-tubesheet joint weld of unspecified strength applied between the tubes and tubesheets for the sole purpose of reducing the potential for leakage

3.17**strength-welded**

tube-to-tubesheet joint welded so that the design strength is equal to, or greater than, the axial tube strength specified by the pressure design code

3.18**structural welding code**

recognized structural welding code specified or agreed by the purchaser

3.19**tube bundle**

assembly of U-tubes, tube sheet and baffles where the tubes can be plain or finned

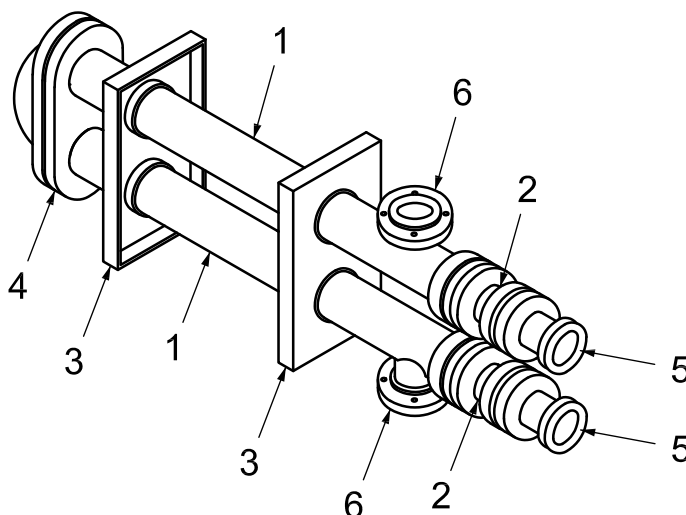
**Key**

1 shell	4 rear closure
2 front closure	5 tube side connection
3 support	6 shell side connection

Figure 1 — Typical components of a hairpin heat exchanger

4 General

- **4.1** The pressure design code shall be specified or agreed by the purchaser. Pressure components shall comply with the pressure design code and the supplemental requirements in this International Standard.
- 4.2** Where the use of TEMA is specified within this International Standard, the heat-exchanger construction shall conform to TEMA, Class R, unless another TEMA class is specified.
- 4.3** Hairpin exchangers typically do not require expansion joints. However, it can be necessary to evaluate some units to assess the requirement for an expansion joint. For such cases, the purchaser and vendor shall agree to all relevant design, fabrication, inspection and testing requirements.

- 4.4 The vendor shall comply with the applicable local regulations specified by the purchaser.
- 4.5 Annex A includes recommended mechanical and design details for information.
- 4.6 Annex B provides a checklist that can be used by the purchaser to ensure that bulleted items in this International Standard are addressed.
- 4.7 The purchaser shall specify whether the service is designated as sour in accordance with ISO 15156 (all parts) for oil and gas production facilities and natural gas sweetening plants, or designated as wet hydrogen sulfide service in accordance with NACE MR0103 for other applications (e.g. petroleum refineries, LNG plants and chemical plants), in which case all materials in contact with the process fluid shall meet the requirements of the applicable standard to mitigate potential for sulfide stress cracking (SSC). Identification of the complete set of materials, qualification, fabrication and testing specifications to prevent in-service environmental cracking is the responsibility of the user (purchaser).

NOTE For the purpose of this provision, NACE MR0175 is equivalent to ISO 15156 (all parts).

5 Proposal information required

5.1 The vendor's proposal shall include, for each heat exchanger unit, completed data sheets such as those given in Annex C.

5.2 For components that are not fully identified by Clause 3, the vendor shall describe the details of construction and assembly.

5.3 The proposal shall include a detailed description of all exceptions to the requirements of the purchaser's inquiry.

5.4 For stacked heat exchangers, the vendor shall supply the following components unless otherwise specified by the purchaser:

- a) bolts, nuts and gaskets for interconnecting nozzles;
- b) shims and bolting for interconnecting supports;
- c) external, interconnecting tube side piping.

5.5 The vendor shall supply a recommended spare parts list for each hairpin heat exchanger.

6 Drawings and other required data

6.1 Outline drawings and other supporting data

6.1.1 The vendor shall submit, for review by the purchaser, outline drawings for each heat exchanger unit. The drawings shall include the following information:

- a) service, item number, project name and location, purchaser's order number, vendor's shop order number and other special identification numbers;
- b) design pressure, test pressure, maximum design temperature, minimum design metal temperature and any restriction on testing or operation of the heat exchanger;
- c) maximum allowable working pressure (MAWP) in the corroded condition and at the design temperature for the shell side and tube side;
- d) connection sizes, location, orientation, projection, direction of flow and, if flanged, the rating and facing;

- e) coupling sizes, rating and orientation;
- f) dimensions, orientation and location of supports, including bolt holes and slots, and the stacking arrangement;
- g) overall dimensions of the heat exchanger;
- h) tube bundle removal clearance;
- i) mass of the heat exchanger, empty and full of water, and of removable components with a mass greater than 25 kg (60 lb), (e.g. removable tube bundle, individual front closure and rear closure);
- j) specified corrosion allowance for each side of the heat exchanger;
- k) references to the applicable code and the purchaser's specification;
- l) requirements for post-weld heat treatment;
- m) requirements for NDE examination;
- n) requirements for material impact testing;
- o) requirements for surface preparation and painting;
- p) gasket materials;
- q) insulation thickness;
- r) location and orientation of nameplates, lifting lugs, grounding clips or other attachments;
- s) location of the centre of gravity of the exchanger for empty and full of water;
- t) material specifications and grades for all components;
- u) forces and moments on connections as specified by the purchaser;
- v) tube-to-tubesheet joint welding and testing procedures.

6.1.2 The vendor shall recommend the tools required for the assembly and maintenance of the hairpin heat exchanger. If torquing of bolts is required, the vendor shall provide torquing procedures.

6.1.3 The review of engineering documents by the purchaser shall not relieve the vendor of the responsibility of meeting the requirements of the purchase order.

6.2 Information required after outline drawings are reviewed

6.2.1 Generic gasket information, including type and material, shall be provided.

6.2.2 Upon receipt of the purchaser's review comments on the outline drawings, the vendor shall submit copies of all detailed (non-proprietary) drawings. These shall fully describe the heat exchanger and shall include at least the following information:

- a) full views and cross-sectional views including tube bundle details with dimensions and materials;
- b) bundle details, including the following:
 - tube layout,

- number of baffles, type and description (for segmental baffles include cross-baffle cut, layout and orientation in a view that shows the cut),
 - details and locations of all sealing and sliding strips;
 - c) details of each pressure-retaining weld, including weld material, weld nominal thickness, weld location and applicable non-destructive examination method;
 - d) details of each weld and weld nominal thickness for non-pressure attachments welded to pressure parts and for all load bearing attachments;
 - e) complete bills of materials, including the material specifications and part numbers for all proprietary components;
 - f) details of cladding and weld overlay;
 - g) details of tube-to-tubesheet joints, including procedures for installation, welding, expansion, inspection and testing;
 - h) flange-face finish.
- **6.2.3** If specified by the purchaser, the vendor shall furnish copies of applicable welding procedure specifications, procedure qualifications and weld map for review or record.
 - **6.2.4** The purchaser shall specify whether the vendor shall furnish for the purchaser's review or record the following documentation:
 - a) mechanical design calculations for shell thickness, tube thickness, nozzle reinforcement and other non-proprietary pressure-retaining components. If calculations are made using computer software, all input and output data shall be detailed so as to facilitate an understanding of the calculation procedures. The equations in the applicable sections of the pressure design code and TEMA shall be referenced;
 - b) minimum required thicknesses for all pressure-retaining components, whether they are proprietary or non-proprietary;
 - c) maximum allowable working pressure calculations (MAWP);
 - d) design calculations based on seismic, wind, transportation and/or piping loads, if these loads are provided by the purchaser;
 - e) proposed procedures for assembly of flanged joints. Any required lubricants shall be stated;
 - f) design calculations for thermal loads imposed on nozzles of stacked heat exchangers;
 - g) flow-induced vibration analysis;
 - h) where sour or wet hydrogen sulfide service is specified, a Certified Material Test Report (CMTR) shall be supplied for all carbon steel materials in contact with the process fluid.

6.3 Reports and records

- After the heat exchanger is completed, the vendor shall furnish the purchaser with the following documents in the format and quantities specified by the purchaser:
 - a) "as-built" data sheet;
 - b) all outline and non-proprietary detail drawings, marked "CERTIFIED AS-BUILT";
 - c) certified record of all impact tests performed;

- d) certified mill test reports for all pressure-retaining parts, including tubes (each material test report shall be identified by a part number);
- e) complete certified bill of materials suitable for obtaining all replacement parts, including quantity, description, material specification and identification of each part;
- f) temperature charts of all post-weld heat treatments;
- g) completed manufacturer's data report in accordance with the pressure design code;
- h) nameplate rubbing or a facsimile;
- i) all as-built mechanical design calculations;
- j) non-destructive examination (NDE) map;
- k) all associated NDE reports, including radiographic, magnetic-particle, liquid-penetrant, ultrasonic, hardness, impact, positive material identification (PMI) and any other reports as applicable;
- l) tube-wall reduction results;
- m) tube-to-tubesheet leak-test results;
- n) hydrostatic test records in the form of a chart or certification;
- o) installation and maintenance instructions including lifting, handling and bundle removal.

7 Design

7.1 Design temperature

- **7.1.1** All heat exchangers shall have two design temperatures for each side, a maximum design temperature and a minimum design metal temperature (MDMT), as specified by the purchaser.

7.1.2 The design temperature of a component (including external bolting) influenced by both the shell side and tube side fluids shall be the more severe design temperature.

7.2 Design pressure

7.2.1 Unless otherwise specified or approved by the purchaser, the heat exchanger shall be designed for design pressure on either side, with atmospheric pressure or, if specified, vacuum on the other side.

7.2.2 If the purchaser specifies that a calculation of maximum allowable working pressure (MAWP) is required, there shall be no restrictions on what components can limit the MAWP of the hairpin heat exchanger. The MAWP shall be as defined in the applicable pressure design code and should be based on all simultaneously existing external loads such as nozzle loads. The presence of external loadings reduces the value of MAWP relative to the case where pressure is the only load present.

7.3 Cyclic design

- **7.3.1** The purchaser shall specify if cyclic service design is required.
- **7.3.2** If cyclic service is specified, the purchaser shall specify the variation, the time for the variation (hours, weeks, months, etc.) and the number of cycles or frequency for this variation expected during the life of the equipment.
- **7.3.3** If cyclic service is specified, the purchaser shall define the type of analysis required.

7.4 Shell

7.4.1 The minimum thickness of the shell shall conform to TEMA, Class R, unless another TEMA class is specified. For shell diameters smaller than those covered by TEMA, at least schedule 40 for carbon steel and low-alloy steel and schedule 10 S for high alloy material shall be used.

7.4.2 Spiral welded pipe shall not be used.

7.5 Front closure

7.5.1 Front closures are typically of a proprietary design utilizing either a common set of bolts (as shown in Figure 2) or separate shell side and tube side bolting (as shown in Figure 3).

7.5.2 Separate shell side and tube side bolting shall be used in the following conditions:

- a) for services where the differential temperature (design or operating, whichever is greater) across the tubesheets is greater than 220 °C (400 °F);
- b) design pressure for either side exceeds 7 000 kPa (ga) (1 000 psig);
- c) cyclic service;
- d) hydrogen service;
- e) when specified by the purchaser.

7.5.3 In units where the shell side and tube side share a common set of bolts, the design temperature used for the bolting shall be the more severe of the shell side or tube side design temperature. For such units, if the manufacturer's design utilizes an intermediate or centre flange with threaded bolt holes, this centre flange shall be designed for the more severe of the shell side or tube side design temperature as well as the higher of the shell side or tube side design pressure.

7.5.4 Corrosion allowances shall not be applied to split rings.

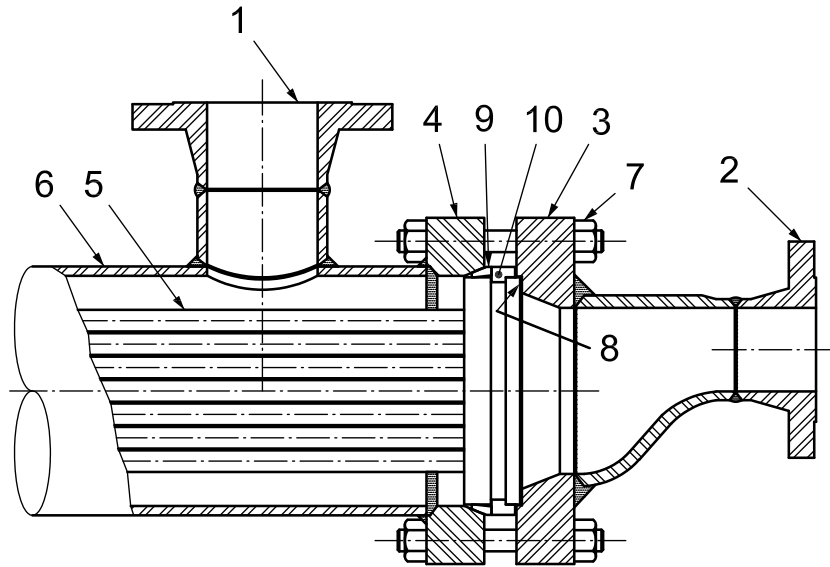
**Key**

1 shell nozzle flange	6 shell pipe
2 tube nozzle flange	7 closure bolting
3 tube flange	8 tube gasket
4 shell end flange	9 sealing ring
5 tube bundle or element	10 shell closure split ring

NOTE This is only a typical configuration. Other configurations are equally acceptable, e.g. the front closure can have a concentric reducer, an eccentric reducer orientated flat-bottom or no reducer at all. Similarly, key item 2 can be absent with the tube side connection being a simple butt-welded preparation. For non-removable front closures, flanges, bolting and gaskets are eliminated.

Figure 2 — Typical front closure

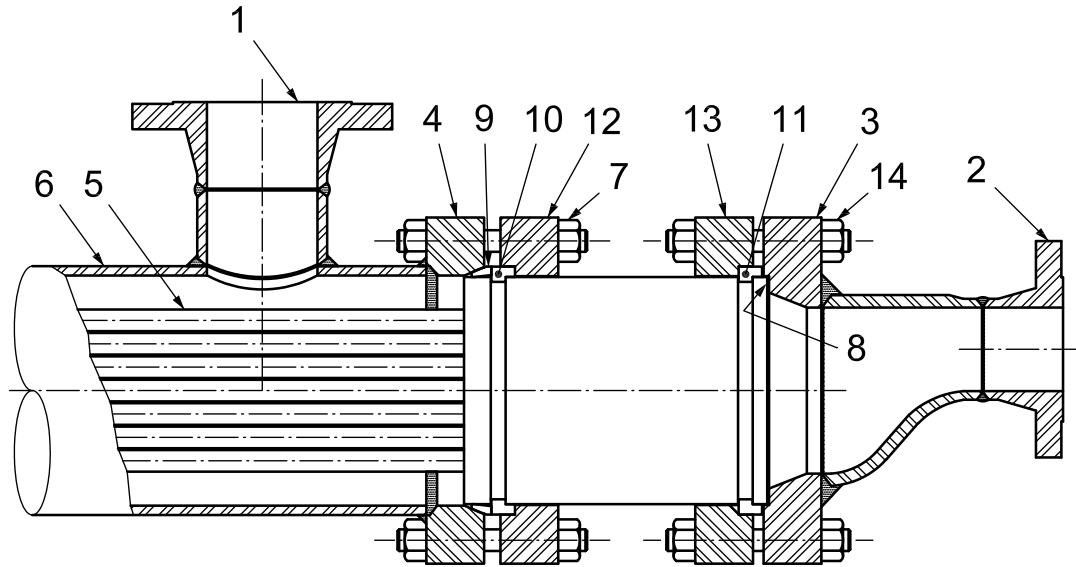

Key

- | | |
|--------------------------|-----------------------------|
| 1 shell nozzle flange | 8 tube gasket |
| 2 tube nozzle flange | 9 sealing ring |
| 3 tube flange | 10 shell closure split ring |
| 4 shell end flange | 11 tube closure split ring |
| 5 tube bundle or element | 12 compression flange |
| 6 shell pipe | 13 tube fitting flange |
| 7 closure bolting | 14 tube closure bolting |

NOTE This is only a typical configuration. Other configurations are equally acceptable, e.g. the front closure can have a concentric reducer, an eccentric reducer orientated flat-bottom or no reducer at all. Similarly, key item 2 can be absent with the joint being a simple butt-welded preparation. For non-removable front closures, flanges, bolting and gaskets are eliminated.

Figure 3 — Typical separated head front closure

7.6 Rear closure

7.6.1 Two typical rear closure arrangements are shown in Figure 4.

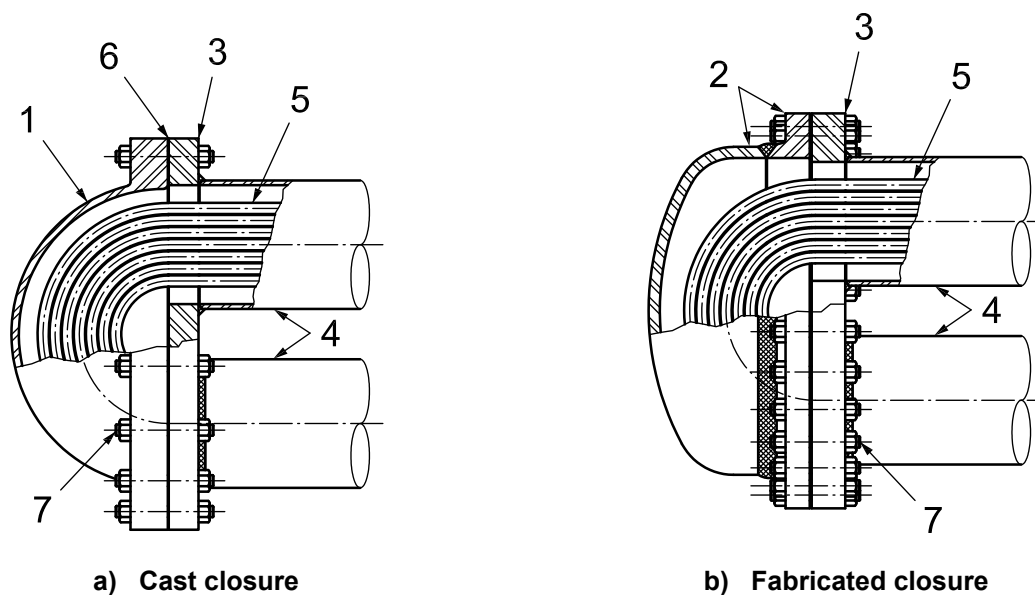
**Key**

- | | |
|-----------------------------------|-------------------------------|
| 1 shell return bend housing | 5 bundle or element assembly |
| 2 shell return housing assembly | 6 return bend housing gasket |
| 3 shell return housing end flange | 7 return bend housing bolting |
| 4 shell pipes | |

These are only typical configurations for removable rear closures. Other configurations are equally acceptable. For non-removable rear closures flanges, bolting and gaskets are eliminated.

Figure 4 — Typical rear closures

7.6.2 The minimum clearance between the tubes and the rear closure, under any of the specified conditions, shall be 6 mm (1/4 in).

7.6.3 For hydrogen, sour or wet hydrogen sulfide service, a confined gasket construction in accordance with TEMA Clause R-6.5 shall be provided for the rear closure.

7.7 Tube bundle

7.7.1 Tubes

7.7.1.1 The inner pipe or tube bundle of the heat exchanger shall be removable through the use of bolted closure joints unless an all welded design is approved by the purchaser.

7.7.1.2 The minimum outside diameter of the tubes shall be 19,05 mm (3/4 in) unless otherwise specified or approved by the purchaser.

7.7.1.3 For tube bundles where the tube element is manufactured from tubing, the minimum tube-wall thickness shall be as listed in Table 1 unless otherwise specified or approved by the purchaser.

Table 1 — Minimum wall thickness of tubes

Dimensions in millimetres (inches)

Tube material	Minimum wall thickness ^{ab}
Carbon steel, low-alloy material (max. 9 % chromium), aluminium and aluminium alloy	2,11 (0,083)
Copper and copper alloys	1,65 (0,065)
High-alloy [austenitic, ferritic and austenitic/ferritic (duplex)] steel and other non-ferrous materials	1,473 (0,058)
Titanium	1,067 (0,042)
^a For low-fin tubing, this shall be the minimum thickness at the root diameter. ^b Average wall basis can be used provided the wall thickness is not less than that specified.	

7.7.1.4 For tube bundles where the tube element is manufactured from pipe, the minimum wall thickness shall be schedule 40 for carbon steel and low-alloy steel and schedule 5 S for high alloy material.

- **7.7.1.5** The purchaser shall specify when a hairpin exchanger has been selected to mitigate a complete tube rupture scenario, which would otherwise require a provision for pressure relief in accordance with ISO 23251. In such cases, the hairpin exchanger shall meet the following.

- A double-pipe (pipe-in-pipe) configuration shall be used. A multi-tube hairpin type exchanger shall not be permitted.
- The inner element shall be made from pipe and shall be of the same schedule or thicker than the connecting pipe. The purchaser shall specify the connecting pipe schedule on the datasheet.
- The minimum required wall thickness calculations for the inner pipe shall include the full hot and cold side corrosion allowance as specified on the datasheet.

NOTE For the purpose of this provision, API Std 521 is equivalent to ISO 23251.

- **7.7.1.6** The purchaser shall specify any maximum allowable length of straight tube due to plot limitations etc.

7.7.2 Transverse segmental baffles and tube supports

7.7.2.1 The thickness of segmental baffles and support plates shall be in accordance with TEMA. Where the shell diameter is below 150 mm (6 in), then the thickness for 150 mm (6 in) diameter shells shall be used.

7.7.2.2 Notched transverse baffles and support plates shall have notches that are 6 mm (1/4 in) high to facilitate drainage for shell diameters up to and including 406 mm (16 in). Above this diameter, notches shall be 10 mm (3/8 in) high.

7.7.2.3 Maximum baffle spacing for bare and low-fin tubes shall be in accordance with TEMA.

7.7.3 Impingement protection

7.7.3.1 If required by TEMA standards (RCB-4.61), impingement protection shall be provided by impingement sleeves, plate or rods on the tube bundle, a distributor belt, or another means agreed upon by the purchaser and the vendor. A typical impingement sleeve is shown in Figure 5.

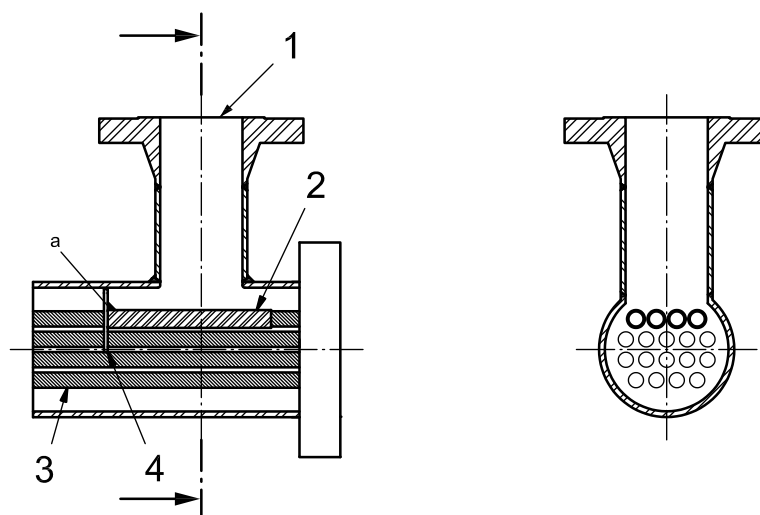
**Key**

- 1 shell side nozzle
- 2 impingement sleeve ^a
- 3 tubes
- 4 first baffle

^a The impingement sleeve should be welded to the first baffle.

Figure 5 — Typical impingement sleeve

7.7.3.2 If an impingement plate is used,

- a) it shall extend at least 25 mm (1 in) beyond the projection of the nozzle bore unless otherwise agreed with purchaser;
- b) the nominal thickness of impingement plates from carbon steel or low-alloy steel shall be not less than 6 mm (1/4 in) unless otherwise agreed with purchaser;
- c) the impingement plate shall be adequately supported, e.g. by welding to at least two spacers, to avoid mechanical damage due to vibration;
- d) it shall not be perforated.

7.7.3.3 Impingement protection shall be provided on both legs to allow for bundle rotation except in shell side vaporizing service.

7.7.3.4 The rho-V-squared values at the shell and bundle entrance and exit areas shall not exceed the limits specified by TEMA Standards.

7.7.4 Bundle skid bars

7.7.4.1 For all removable bundles with a mass of more than 5 500 kg (12 000 lb), a continuous sliding surface shall be provided to facilitate bundle removal. If skid bars are used, they shall be welded to the transverse baffles and supports to form a continuous sliding surface.

7.7.4.2 Skid bars shall protrude at least 1 mm (1/32 in) beyond the outside diameter of baffle and supports.

7.7.4.3 The leading and trailing edges of skid bars shall be provided with a radius or a bevel to prevent damage to the shell when inserting or removing the bundle.

7.7.4.4 Provision shall be included to protect tubesheet sealing surface from damage during bundle insertion or removal.

7.7.5 Tube-to-tubesheet joint

The tube-to-tubesheet joint shall be in accordance with the TEMA standard unless otherwise specified by the purchaser.

7.8 Nozzles and other connections

7.8.1 Flanges shall be in accordance with the pressure design code unless otherwise specified by purchaser.

7.8.2 Connections DN 40 (NPS 1½) and larger shall be flanged unless otherwise specified by the purchaser.

7.8.3 Connection sizes of DN 32 (NPS 1¼), DN 65 (NPS 2½), DN 90 (NPS 3½) or DN 125 (NPS 5) shall not be used.

7.8.4 If welded connections are specified, they shall be bevelled.

7.8.5 Non-flanged connections smaller than DN 40 (NPS 1½) shall be forged couplings with an appropriate rating, for example equivalent to ASME B16.11 class 6000, or shall be integrally reinforced welding fittings with appropriate tapered threads, for example equivalent to ASME B1.20.1, and shall comply with the pressure design code. Threaded connections shall not be used in hydrogen, sour or wet hydrogen sulfide service. This includes auxiliary connections such as vents, drains, instrument connections and chemical cleaning connections.

7.8.6 Flanged connections shall be of one of the following types:

- a) forged integrally flanged;
- b) pipe or forged cylinder welded to forged welding-neck flange;
- c) pipe welded to a forged slip-on flange, except as noted in 7.8.7.

7.8.7 Slip-on flanges shall not be used in any of the following conditions:

- a) for design pressure exceeding 2 100 kPa (ga) (300 psig);
- b) for design temperature exceeding 400 °C (750 °F);
- c) for corrosion allowance exceeding 3 mm (1/8 in);
- d) in hydrogen service, sour, or wet hydrogen sulfide service;
- e) in cyclic service.

- **7.8.8** When specified by the purchaser, the projection of flanged connections shall allow the removal of through-bolting from either side of the flange without removing the insulation. This requirement does not apply to the interconnecting nozzles of stacked units. The insulation thickness shall be specified by the purchaser.

7.8.9 Integrally reinforced nozzles shall be designed so that standard spanners (wrenches) fit the nuts without interference from nozzle neck reinforcement.

7.8.10 All bolt holes for flanged or studded connections shall straddle centrelines.

- **7.8.11** The purchaser shall specify if chemical cleaning connections are required. Their nominal size shall be not less than DN 50 (NPS 2). Chemical cleaning connections shall not be utilized on the tube side of exchangers.

7.8.12 Each nozzle as defined in 7.8.14, in its corroded condition, shall be capable of withstanding the simultaneous application of the moments and forces listed in Tables 2 and 3, unless otherwise specified by the purchaser.

7.8.13 The points of application and directions of the forces and moments are shown in Figure 6. These moments and forces shall be the total from all sources, including dead loads and thermal loads.

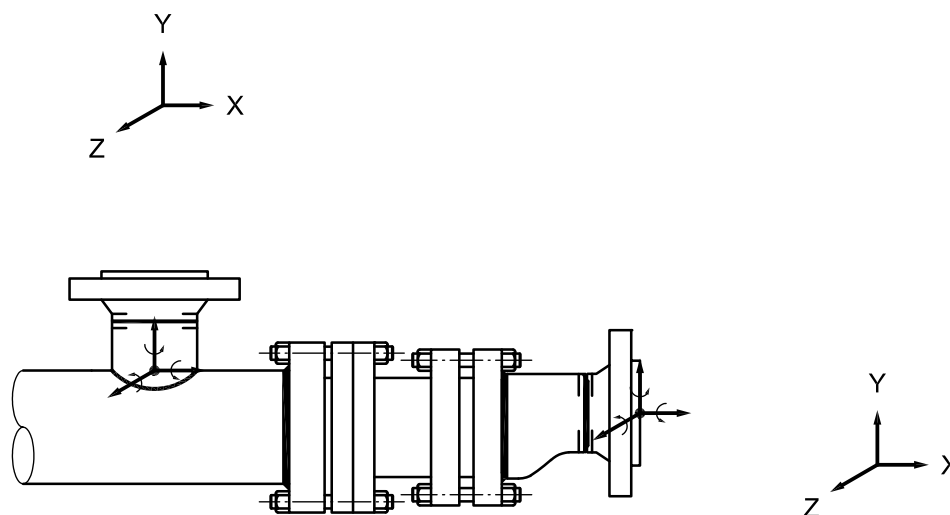

NOTE 1 Force vector "X" is in the direction of the heat exchanger's centreline.

NOTE 2 "•" indicates the point of application for the forces and moments on the connection.

Figure 6 — Directions of forces and moments on connections

7.8.14 The nozzle moments and forces listed in Tables 2 and 3 shall be used for hairpin exchangers. The tables are based on the following criteria.

- The support closest to the shell nozzles is fixed.
- Shell material is carbon steel.
- Shell side design pressure does not exceed 60 % of the maximum allowable pressure of the corroded shell calculated for internal pressure only.
- Shell side design temperature does not exceed 350 °C (650 °F).
- Shell diameter is at least one size bigger than the nozzle size.
- Nominal shell thickness is at least standard weight pipe wall thickness.
- Minimum corroded shell thickness is not less than 2,5 mm (3/32 in).
- Shell corrosion allowance is not greater than 3 mm (1/8 in).
- Minimum nozzle thickness is at least schedule 160 for nominal nozzle sizes up to 50 mm (2 in) and schedule 80 for nominal nozzle sizes 80 mm (3 in) and above.
- There shall be no additional connections fitted on the tube side nozzle reducers that will extend the typical location of the terminal connection from the front closures as shown in Figures 2 and 3.

- k) Front closures are adequately oversized with extra equivalent pressure above the design pressures to allow room for the tube side nozzle loads.
- l) The exchanger is a single, non-stacked unit and is not exposed to wind, seismic or motion loads.

Table 2 — Shell side nozzle allowable forces and moments at nozzle-to-header intersection on the shell surface

Nominal diameter		M_x		M_y		M_z		F_x		F_y		F_z	
DN	(NPS)	N·m	(lbf·ft)	N·m	(lbf·ft)	N·m	(lbf·ft)	N	(lbf)	N	(lbf)	N	(lbf)
50	2	115	85	115	85	115	85	266	60	266	60	266	60
80	3	135	100	135	100	135	100	333	75	333	75	333	75
100	4	237	175	237	175	237	175	667	150	667	150	667	150
150	6	372	275	372	275	372	275	1 000	225	1 000	225	1 000	225
200	8	542	400	542	400	542	400	1 556	350	1 556	350	1 556	350
250	10	745	550	745	550	745	550	2 001	450	2 001	450	2 001	450
300	12	1 172	865	1 172	865	1 172	865	2 313	520	2 313	520	2 313	520

Table 3 — Tube side nozzle allowable forces and moments at the face of the terminal connection

Nominal diameter		M_x		M_y		M_z		F_x		F_y		F_z	
DN	(NPS)	N·m	(lbf·ft)	N·m	(lbf·ft)	N·m	(lbf·ft)	N	(lbf)	N	(lbf)	N	(lbf)
50	2	79	59	79	59	79	59	186	42	186	42	186	42
80	3	94	70	94	70	94	70	231	52	231	52	231	52
100	4	165	122	165	122	165	122	467	105	467	105	467	105
150	6	260	192	260	192	260	192	698	157	698	157	698	157
200	8	379	280	379	280	379	280	1 089	245	1 089	245	1 089	245
250	10	521	385	521	385	521	385	1 401	315	1 401	315	1 401	315
300	12	820	605	820	605	820	605	1 619	364	1 619	364	1 619	364

NOTE Forces (F) and moments (M) shown in Tables 2 and 3 were determined as follows.

- a) For each nozzle size, the same maximum values for forces and moments in all three directions, i.e. $F_x = F_y = F_z$, and $M_x = M_y = M_z$ were adopted.
- b) The worst-case assumptions were made as listed above in the criteria to allow the application of the table values to a wide range of exchanger parameters.
- c) These assumed exchangers were analyzed as a whole system considering the general stresses in the shell, local stresses in the nozzle-to-shell junction, front end closure integrity, support stresses, and anchor bolt stresses to determine the weakest link.

7.8.15 The nozzle-to-shell junction shall be analyzed using WRC 537 or finite element analysis (FEA) with the pressure thrust load applied simultaneously with the nozzle loads in Table 2. In addition, the effect of tube side nozzle loads shall be investigated and accounted for at the nozzle to shell junction.

7.8.16 Front closures shall be designed to withstand the tube side nozzle loads shown in Table 3 using the equivalent pressure, P_e , expressed in kilopascals (gauge) as calculated by Equation (1) for SI units or expressed in pounds per square inch (gauge) as calculated by Equation (2) for USC units:

In SI units:

$$P_e = \left[\frac{(16 \times 10^6 \times M)}{(\pi \times G^3)} \right] + \left[\frac{(4\,000 \times F)}{(\pi \times G^2)} \right] + P \quad (1)$$

In USC units:

$$P_e = \left[\frac{(192 \times M)}{(\pi \times G^3)} \right] + \left[\frac{(4 \times F)}{(\pi \times G^2)} \right] + P \quad (2)$$

where

M is the bending moment (vector quantity), expressed in N · m (lbf ft); see Equations (4) or (5);

F is the force (vector quantity), expressed in N (lbf); see Equation (3);

G is the gasket reaction diameter, expressed in mm (in); see Table 4;

P is the design pressure, expressed in kPa (ga) (psig).

$$F = F_x \quad (3)$$

In SI units:

$$M = \left\{ \left[M_y + (F_x \times 10^{-3} \times d_z) + (F_z \times 10^{-3} \times d_x) \right]^2 + \left[(M_z + F_x \times 10^{-3} \times d_y) + (F_y \times 10^{-3} \times d_x) \right]^2 \right\}^{1/2} \quad (4)$$

In USC units:

$$M = \left\{ \left[M_y + \left(F_x \times \frac{d_z}{12} \right) + \left(F_z \times \frac{d_x}{12} \right) \right]^2 + \left[M_z + \left(F_x \times \frac{d_y}{12} \right) + \left(F_y \times \frac{d_x}{12} \right) \right]^2 \right\}^{1/2} \quad (5)$$

where

F_x, F_y and F_z are the nozzle forces on each axis as diagrammed in Figure 6;

M_x, M_y and M_z are the nozzle moments acting about each axis as diagrammed in Figure 6;

d_x, d_y and d_z are the distances between the point of application of the forces / moments and the centre of the gasketed joints (shell or tube side closure joint) being analyzed in the x, y, and z directions, respectively, as shown in Figure 6, expressed in millimetres (inches).

In addition, the bolting of the front closure shall be designed to withstand the shear force, V , expressed in newtons as calculated in Equation (6) or expressed in pounds-force as calculated in Equation (7):

In SI units:

$$V = (F_y^2 + F_z^2)^{1/2} + \left(\frac{2 \times 10^3 \times M_x}{D_{BC}} \right) \tag{6}$$

In USC units:

$$V = (F_y^2 + F_z^2)^{1/2} + \left(\frac{24 \times M_x}{D_{BC}} \right) \tag{7}$$

where D_{BC} is the bolt circle diameter of the closure being analyzed, expressed in millimetres (inches).

7.8.17 The equivalent pressure uses the tube side closure flange gasket mean diameter for the separate bolting head closure, or the shell side closure flange gasket mean diameter for the common bolting head closure as G in the calculation (Table 4). The calculated equivalent pressure, P_e , shall be equal to or lesser than the MAWP of each front closure and the centre flange on the common head closure type. It is necessary that all three forces and moments acting on the nozzle be accounted for.

Table 4 — G values for tube side allowable nozzle load calculation

Nominal shell diameter		G		
		Separated bolting closure		Common bolting closure
DN	(NPS)	mm	(in)	mm (in)
50	2	33	1,3	(Use nominal pipe size)
80	3	56	2,2	
100	4	84	3,3	
125	5	107	4,2	
150	6	135	5,3	
200	8	183	7,2	
250	10	230	9,1	
300	12	275	10,8	

7.8.18 Shell side and tube side nozzle flanges in high temperature service (above 200 °C (400 °F) for ASME B16.5 Class 150 flanges, or above 400 °C (750 °F) for ASME B16.5 Class 300 and higher flanges, shall be checked using the following procedure.

Calculate the equivalent pressure, P_e , for G , the gasket reaction diameter, corresponding to the nozzle flange using Equation (1) or Equation (2) for SI or USC units, respectively.

If the calculated P_e is equal to or less than the rated pressure of the nozzle flange in accordance with ASME B16.5, the selected flange is acceptable; otherwise, use the next higher flange pressure class.

7.8.19 The heat exchanger shall be drainable and ventable through the connections for all pass arrangements. Eccentric reducers can be used to provide this.

7.9 Shell supports

7.9.1 Both legs of the exchanger's shell shall be fixed at the support closest to the tubesheet unless otherwise specified by the purchaser.

7.9.2 When the fixed shell support of a removable-bundle heat exchanger is fixed to the shell, it shall be designed to withstand a longitudinal force equal to 150 % of the bundle mass applied at the heat exchanger bundle centreline. The shear stress for supports shall not exceed 40 % of the yield strength of the material.

7.9.3 Support material in direct contact with the shell shall be of the same nominal composition as the shell.

7.9.4 The lower shells of stacked removable-bundle heat exchangers shall be designed to carry the superimposed loads without suffering distortion that can cause binding of the tube bundles.

7.9.5 All units shall have at least one earthing lug, welded directly to a suitable shell side component.

7.10 Gaskets

7.10.1 Spiral-wound gaskets, where used, shall be provided with a means to prevent over-compression and buckling.

7.10.2 Gaskets shall be of a one-piece design. Gaskets made integral by no more than two welds are acceptable.

7.11 Flanged external girth joints

7.11.1 External girth joints shall be of through-bolted construction, unless otherwise approved by the purchaser.

7.11.2 Minimum bolt diameter shall be 12 mm (1/2 in).

7.11.3 Slip-on flanges shall not be used as girth flanges.

7.11.4 The gap between mating flanges after assembly shall be not less than 3 mm (1/8 in) and this gap shall extend within the bolt circle to allow checking the flanges for radial distortion caused by an excessive bolt load.

7.11.5 Through-hardened washers shall be provided under nuts for all bolts having a diameter of 38 mm (1 1/2 in) or larger unless hydraulic bolt tensioners are used. The washers shall be at least 6 mm (1/4 in) thick.

- **7.11.6** The purchaser shall specify if bolt-tightening devices will be used. When used, the nozzles and/or girth flanges shall be designed to allow adequate clearance.

7.12 Cladding for corrosion allowance

7.12.1 If cladding (including weld overlay) is used, the cladding thickness shall be used only as corrosion allowance and not for pressure design.

7.12.2 The cladding thickness at the tube side face of a tubesheet shall be not less than 10 mm (3/8 in) when tubes are expanded only, and 5 mm (3/16 in) when tubes are welded to the tubesheet. If grooves are used, the first groove shall be within the tube side cladding.

7.12.3 The cladding thickness on the shell side face of a tubesheet shall be not less than 10 mm (3/8 in).

7.12.4 Weld overlays shall have sufficient thickness to provide the specified chemical composition to a depth of at least 1,5 mm (1/16 in).

8 Materials

8.1 General

8.1.1 Cast steel can be used only for the return bend housing.

8.1.2 Material for external parts that are welded directly to the heat exchanger, such as pads, brackets and lugs, shall be of the same nominal composition as the material to which they are welded.

8.1.3 If alloy linings are specified by the purchaser, they shall be weld-overlay, integrally clad or explosion-bonded. Loose liners or sleeves shall not be used without the approval of the purchaser.

8.1.4 Girth flanges can be fabricated from forgings or plate.

8.1.5 Shells and nozzles can be welded pipe, seamless pipe or rolled and welded cylinders.

8.1.6 Shell supports shall be fabricated using structural grade carbon steel unless otherwise specified by the purchaser.

8.2 Requirements for carbon steel in sour or wet hydrogen sulfide service

8.2.1 Materials shall be supplied in the normalized condition, unless otherwise approved by the purchaser. The acceptability of hot-formed material shall be subject to approval of the purchaser.

8.2.2 Pressure-retaining components shall be supplied with a Certified Material Test Report (CMTR). The CMTR shall include the unspecified elements chromium (Cr), columbium (Cb) [also known as niobium (Nb)], nickel (Ni), vanadium (V), molybdenum (Mo) and copper (Cu) that are used in the equation to calculate the carbon equivalent (CE) as defined by ISO 15156 (all parts) or NACE MR0103.

- 8.2.3 The maximum allowable carbon equivalent shall be agreed with the purchaser, prior to purchase of materials for use in fabrication. Restrictions on other residual elements and micro-alloying elements can also apply depending on the severity of the service. The purchaser shall specify any such restrictions.

8.3 Gaskets

8.3.1 Gaskets shall not contain asbestos.

8.3.2 Material for metal-jacketed, serrated-metal or solid-metal gaskets shall have a corrosion resistance at least equal to that of the gasket contact surface material.

8.3.3 Metal windings of spiral-wound gaskets shall be of austenitic stainless steel unless otherwise specified or approved by the purchaser. Where materials of construction are a higher alloy, then the metal windings shall be the same alloy material.

8.3.4 Serrated or solid-metal gaskets, including welds, shall be softer than the gasket contact surface except that for special, high-pressure closure designs (e.g. self-energizing types), the sealing ring may be harder than the gasket contact surfaces.

8.3.5 Gasket material, including filler material, shall be selected to withstand the maximum design temperature.

8.3.6 Compressed sheet type gaskets shall not be used in hydrocarbon, steam, hydrogen, sour or wet hydrogen sulfide service.

8.4 Tubes

8.4.1 Integrally finned tubes of copper alloy shall be furnished in the annealed-temper condition, such as ASTM B359/B359M.

8.4.2 All welded tubes shall be eddy-current tested in the finished condition over their full length.

9 Fabrication

9.1 Shells

9.1.1 For removable heat exchanger bundles, all longitudinal and circumferential welds of shells shall be finished flush with the inner contoured for ease of tube-bundle insertion and withdrawal.

9.1.2 For removable-bundle heat exchangers, the permissible out-of-roundness of a completed shell, after any required heat treatment, shall allow the tubesheets and baffles or tube supports to pass through the entire shell length without binding.

9.2 Tubes

9.2.1 General

Tube elements shall be fabricated from either tubing or pipe material.

9.2.2 Elements made from tubing

9.2.2.1 All plain and low-finned tubes including U-tubes shall be formed from a single length and shall have no circumferential welds unless approved by the purchaser.

9.2.2.2 Tubes with longitudinal fins can have circumferential welds at the bend area.

9.2.2.3 Tube thickness after bending and forming shall not be less than the minimum thickness as required by the pressure design code. Out-of-roundness of the bent portion shall not be greater than 10 % of the tube outside diameter.

9.2.2.4 When not specified by the pressure design code, the minimum tube thickness after bending and forming, t_f , expressed in millimetres (inches), shall be calculated using Equation (8):

$$t_f = \frac{4RT}{4R + D} \quad (8)$$

where

T is the minimum tube thickness required by the pressure design code, expressed in millimetres (inches);

R is the centre line bend radius, expressed in millimetres (inches);

D is the tube nominal outside diameter, expressed in millimetres (inches).

9.2.3 Elements made from pipe

U-bends can be fabricated with circumferential welds using pipe and/or butt weld fittings.

9.3 Welding

9.3.1 Welds can be made by any welding process other than oxyacetylene gas welding.

9.3.2 Pressure-retaining welded joints shall be full-penetration weld type except where slip-on flanges are allowed in accordance with 7.8.

9.3.3 Where slip-on flanges are used, they shall be welded from both sides.

9.3.4 Openings in plate components, to which attachments abut the openings, shall be inspected for laminations. The surface of the opening through the plate shall be examined by means of the magnetic-particle, liquid-penetrant or ultrasonic methods. Subject to agreement with the purchaser, indications found shall be cleared to sound metal and then repair-welded.

9.3.5 Permanent backing strips shall not be used.

9.3.6 All strength-welded tube-to-tubesheet welds shall be produced by gas tungsten arc using filler material.

9.3.7 Welds attaching non-pressure external attachments (such as lugs or structural steel supports) shall be continuous except for insulation support rings.

9.3.8 Repair-associated welding procedures shall be submitted to the purchaser for approval before the start of repair.

9.3.9 Longitudinal fins shall be attached by electric resistance welding. Stitch welding is not acceptable.

- 9.3.10 The purchaser shall specify whether weld procedure qualifications for carbon steel in sour or wet hydrogen sulfide service, including tube to tubesheet welds, shall include a micro-hardness survey performed on a weld cross-section and transverse to the weld centreline. The micro-hardness testing and acceptance criteria shall be in accordance with NACE SP0472 or ISO 15156 (all parts), as applicable. Any additional restrictions on residual elements or micro-alloying elements for the qualification test material shall be specified by the purchaser.

9.4 Heat treatment

9.4.1 Machined contact surfaces, including any threaded connections, shall be suitably protected to prevent scaling or loss of finish during heat treatment.

- 9.4.2 Requirements for heat treatment after bending for the bend portion of U-tubes shall be specified by the purchaser. The procedure shall be agreed between purchaser and vendor.

9.4.3 The heat-treated portion of the U-bend shall extend at least 150 mm (6 in) beyond the tangent point.

- 9.4.4 The purchaser shall specify if heat treatment is required for process reasons.

- 9.4.5 The purchaser shall specify if post-weld heat treatment is required for weld-overlaid components.

9.4.6 For sour or wet hydrogen sulfide service, the minimum post-weld heat treatment requirements for carbon steel construction shall be in accordance with NACE SP0472. The minimum hold time shall be in accordance with the pressure design code, or 1 h, whichever is greater.

9.5 Dimensional tolerances

9.5.1 Manufacturing tolerances shall be in accordance with TEMA except as noted within this International Standard.

9.5.2 Heat exchangers that will be stacked in series shall be stacked in the shop to check connection alignment.

9.5.3 For stacked heat exchangers, the maximum acceptable out-of-parallel tolerance between mating nozzle flanges, measured across any diameter, shall not exceed the limits specified in Table 5. Separation of mating nozzle flanges shall not exceed 3 mm (1/8 in) after installation of the gasket. Bolts shall be capable of being inserted and removed freely without binding. Shims shall be installed as required between the supports and shall be tack-welded in place.

Table 5 — Maximum acceptable out-of-parallel tolerance between mating nozzle flanges

Nominal nozzle diameter		Tolerance mm (in)
DN	(NPS)	
50 to 100	2 to 4	± 1,6 (1/16)
150 to 300	6 to 12	± 2,4 (3/32)

9.6 Gasket contact surfaces other than nozzle flange facings

9.6.1 Gasket contact surfaces shall have finishes as shown in Table 6.

Table 6 — Gasket contact surface finishes

Dimensions in micrometres (micro-inches)

Type	Surface roughness R_a^a
Solid metal gaskets	1,6 (63) maximum
Double jacketed gaskets	1,6 to 3,2 (63 to 125)
Spiral-wound gaskets	3,2 to 6,3 (125 to 250)
Serrated or corrugated metal gaskets with soft gasket-seal facing	
Compressed sheet gaskets	3,2 to 12,5 (125 to 500)

^a R_a is roughness average.

9.6.2 The flatness tolerances on peripheral gasket contact surfaces shall be in accordance with TEMA.

9.6.3 Flange flatness tolerance and surface finish shall be measured after the flange has been attached to the component cylinder or the cover and after any post-weld heat treatment.

9.6.4 The flatness of tubesheet gasket-contact surfaces shall be measured after the tube-to-tubesheet joints have been completed, including any heat treatment.

9.7 Tube-to-tubesheet joints

9.7.1 Tube-hole grooves shall be square-edged, concentric and free from burrs.

9.7.2 If austenitic stainless steel, duplex stainless steel, titanium, cupro-nickel or nickel-alloy tubes are specified, the tube holes shall be machined in accordance with TEMA, Table RCB-7.41, column (b) (Special Close Fit).

9.7.3 Strength-welded joints shall be used when tube hole ligaments are less than those required by TEMA. Tubes shall be given a light contact roll after welding.

9.7.4 Recessed tube-to-tube sheet welds are not acceptable unless agreed with purchaser.

9.7.5 If roller-expanded joints are utilized, the tube wall thickness reduction shall be in accordance with Table 8. For multi-tube exchangers, a minimum of 2 % of the tubes per tube bundle, with a minimum of 3 tubes, shall be randomly checked for conformance to this requirement.

Table 7 — Maximum allowable tube wall thickness reduction for roller-expanded tube-to-tubesheet joints

Material	Maximum tube wall thickness reduction %
Carbon steel and low-alloy (max. 9 % chromium) steel	8 ^a
Stainless and high alloy steel	6 ^a
Titanium and work hardening non-ferrous	5 ^a
Non-ferrous non-work hardening (e.g. admiralty brass)	8 ^a
^a These can be increased by a further 2 %, if approved by the purchaser.	

9.7.6 If welded-and-expanded joints are specified, tube wall thickness reduction should begin at least 6 mm (1/4 in) away from welds.

9.7.7 In no case shall the rolling encroach within 3 mm (1/8 in) of the shell side face of the tubesheet.

9.7.8 For shell-side-clad tubesheets, the tube shall be expanded to seal against the cladding material, for a minimum distance of 6 mm (1/4 in).

9.8 Assembly

9.8.1 The threads of external studs and nuts shall be coated with a suitable anti-seize compound to prevent galling.

9.8.2 The lifting device shall be a weld-on lug or ring provided with a hole not less than 25 mm (1 in) in diameter. Wherever possible, the lug or ring shall be located at the top of the component, above its centre of gravity; otherwise, two suitably located lugs or rings shall be provided. The lifting device shall be designed to support at least twice the mass of the component.

10 Inspection and testing

10.1 Quality assurance

- **10.1.1** The purchaser shall specify if the vendor is required to supply information about its quality control system and if this includes submission of a quality control plan.

10.1.2 No tubes or tube holes shall be plugged without notifying the purchaser. The method and procedure of plugging shall be subject to approval of the purchaser.

10.2 Quality control

10.2.1 For external pressure containing welds, the following requirements apply.

- a) At least one radiograph shall be made of each butt welded joint. Nozzle welds are exempt from this requirement unless required by the pressure design code. The radiographs shall be at least 250 mm (10 in) long or shall be full length if the weld is less than 250 mm (10 in) long.
- b) Weld porosity limits for radiographs shall be as stated in the pressure design code for fully radiographed joints.

10.2.2 A minimum of 10 % of the circumferential joints of tubes or inner pipes shall be fully radiographed.

- **10.2.3** When specified by the purchaser, weld metal of pressure-retaining welds (excluding tube to tubesheet welds) in carbon steel components shall be hardness tested.

10.2.4 Carbon steel welds in cyclic, sour or wet hydrogen sulfide services shall be hardness tested.

10.2.5 Weld metal of pressure-retaining welds (excluding tube-to-tubesheet welds) in components made of Cr-Mo, 11/13/17 % chromium steels and duplex stainless steels shall be hardness tested.

10.2.6 Weld hardness testing for each hairpin section shall be as follows.

- One longitudinal weld, one circumferential weld and each connection-to-component weld if the connection is DN 50 (NPS 2) or larger shall be examined.
- Examination shall be made after any required post-weld heat treatment.
- Unless otherwise agreed between the vendor and purchaser, the weld hardness shall not exceed the values listed in Table 8.
- Hardness readings shall be taken with a portable Brinell hardness tester. Other hardness testing techniques may be employed if approved by the purchaser. When access is available, tests shall be performed on the side of the weld in contact with the process fluid.
- If more than one welding procedure is used to fabricate longitudinal or circumferential welds, hardness readings shall be made of welds deposited by each procedure.
- Hardness test results and locations shall be recorded.

Table 8 — Hardness limits

Material	Maximum weld hardness
Carbon steel	225 HBW
Chromium steel (up to 3 % Cr)	225 HBW
Chromium steel (5 % Cr to 17 % Cr)	241 HBW
Duplex stainless steel (22 % Cr)	to be agreed with Purchaser
Super duplex stainless steel (25 % Cr)	to be agreed with Purchaser
NOTE These hardness values are for general services. More stringent hardness testing and acceptance criteria can be required for special services (e.g. sulfide stress cracking or other types of environmental cracking services as specified in NACE Standards).	

10.2.7 At welded joints in alloy-clad construction, the weld in the base metal and the area adjacent to the weld where the cladding has been stripped back shall be examined by magnetic-particle inspection before weld overlay of the joint.

10.2.8 All finished welds in ferromagnetic steel shall be examined after post-weld heat treatment (unless the pressure design code specifies examination after hydrostatic testing) by the magnetic particle method.

10.2.9 For carbon steel and low-alloy steels in sour or wet hydrogen sulfide service, all accessible wetted surfaces of pressure-retaining welds and attachment welds to the pressure boundary shall be examined by the wet fluorescent magnetic particle method after post-weld heat treatment. Liquid penetrant examination shall be substituted for those welds that cannot otherwise be examined by magnetic particle methods.

10.2.10 Final welds in all non-magnetic materials, whether of solid alloy or alloy-clad plate, shall be examined by the liquid-penetrant method after any required post-weld heat treatment.

10.2.11 After cladding, but prior to fabrication, integrally clad material shall be subjected to an ultrasonic examination from the clad side in accordance with the pressure design code.

10.2.12 Overlay weldments, back-cladding and attachment welds to overlay weldments shall be liquid-penetrant examined after post-weld heat treatment.

10.2.13 For duplex stainless steels, the ferrite content of all accessible completed production welds shall be checked using a ferrite-scope. A minimum of three tests shall be made on each 1,5 m (5 ft) of weld, with at least three tests made on each longitudinal seam, three tests on each circumferential weld seam and three tests on each nozzle weld. The acceptance criteria for the minimum and maximum ferrite content shall be agreed between the purchaser and vendor.

- **10.2.14** The purchaser shall specify whether all carbon steel plate in sour or wet hydrogen sulfide service shall be subjected to an ultrasonic lamination check (e.g. to EN 10160 grade S2E2 or ASME SA-578, acceptance level A supplementary requirement S1).

10.3 Pressure testing

10.3.1 The design of the heat exchanger shall permit full hydrostatic testing on the shell side with the tube side closure components removed either through use of a threaded centre flange, a test ring or alternate means. The shell-side hydrostatic test shall be conducted with the front closure removed.

10.3.2 In the case of welded-and-expanded tube-to-tubesheet joints, the tube weld integrity shall be verified before expansion of the tubes by a pneumatic test from the shell side at a gauge pressure of between 50 kPa (7,5 psi) and 100 kPa (15 psi), using a soap-water solution to identify leaks.

10.3.3 Except for differential-pressure designs, an independent hydrostatic test of the shell side and the tube side shall be performed. The minimum fluid temperature for hydrostatic testing shall be as required by the pressure design code.

10.3.4 The water used for hydrostatic testing shall be potable and the test pressure shall be maintained for at least 1 h.

10.3.5 The chloride content of the test water used for equipment with austenitic stainless steel materials that can be exposed to the test fluid shall not exceed 50 mg/kg (50 parts per million by mass). Upon completion of the hydrostatic test, the equipment shall be promptly drained and cleared of residual test fluid.

- **10.3.6** Any additional requirements for equipment drying or preservation shall be specified by the purchaser.

10.3.7 Nozzle reinforcement pads shall be pneumatically tested between 100 kPa (ga) (15 psig) and 170 kPa (ga) (25 psig).

10.3.8 Joints taken apart after the final pressure test shall be reassembled with new gaskets. Self energizing seals can be reused subject to approval of the purchaser.

10.3.9 Paint or other external coatings shall not be applied over welds before the final hydrostatic test unless otherwise agreed by the purchaser.

10.3.10 Heat exchangers that will be stacked in service shall be hydrotested stacked.

10.4 Nameplates and stampings

10.4.1 An austenitic stainless steel nameplate shall be permanently attached to the heat exchanger in such a manner that it is visible after insulation has been installed.

10.4.2 The nameplate shall be located on the shell, near the channel end.

10.4.3 The following parts shall be stamped with the manufacturer's serial number:

- a) shell leg;
- b) shell closure flange;
- c) tube closure flange;
- d) return closure;
- e) tubesheets;
- f) test ring flange and gland.

11 Preparation for shipment

11.1 Protection

11.1.1 All liquids used for cleaning or testing shall be drained from heat exchangers before shipment.

11.1.2 Heat exchangers shall be free from foreign matter prior to shipment.

11.1.3 All openings in heat exchanger units shall be suitably protected to prevent damage and possible entry of water or other foreign material.

11.1.4 All flange-gasket surfaces shall be coated with an easily removable rust preventative and shall be protected by suitably attached durable covers of such material as wood, plastic or gasketed steel.

11.1.5 All threaded connections shall be protected by metal plugs or caps of compatible material.

11.1.6 Connections that are bevelled for welding shall be suitably covered to protect the bevel from damage.

- **11.1.7** The purchaser shall specify if there are requirements for surface preparation and protection (e.g. painting).

11.1.8 Exposed threads of bolts shall be protected with an easily removable rust preventative to prevent corrosion during testing, shipping and storage. Tapped holes shall be plugged with grease.

- **11.1.9** The purchaser shall specify if inert gas purge and fill is required. Positive pressure shall be indicated by a pressure gage. Gages shall be suitably protected from damage during transportation. Purchaser shall maintain the positive pressure of the inert gas during storage.

11.2 Identification

11.2.1 The item number, shipping mass and purchaser's order number shall be clearly marked on the heat exchanger.

11.2.2 All boxes, crates or packages shall be identified with the purchaser's order number and the item number.

11.2.3 The words "DO NOT WELD" shall be stencilled on the parts of the equipment that have been post-weld heat-treated.

12 Supplemental requirements

12.1 General

- The purchaser shall specify if the additional requirements in Clause 12 shall be applied to one or both sides of the heat exchanger. These supplemental requirements should be considered by the purchaser if the cylinder thickness of a heat exchanger component exceeds 50 mm (2 in), or if the service is considered critical.

12.2 Design

The attachment of welded nozzles and other connections to components shall have integral reinforcement. The nozzles or other connections shall be attached using full-penetration groove weld with additional fillet or butt welds. They can be set-on, set-in, or integrally reinforced forging type inserts. Set-on type connections shall not be welded to plate that contains laminations or other defects and shall be used only if the component is pipe or forged or if the component plates are ultrasonically examined in the area of attachment. In this case, the examination for laminations and other defects shall be carried out for a radial distance of at least twice the thickness of the component.

12.3 Examination

12.3.1 All material for formed heads or cylinders exceeding 50 mm (2 in) in thickness shall be ultrasonically examined. Non-destructive examination procedures and acceptance criteria shall comply with the pressure design code.

12.3.2 All forgings, except standard flanges designed as described in 7.8, shall be ultrasonically examined in accordance with the pressure design code. Non-destructive examination procedures and acceptance criteria shall comply with the pressure design code and shall be approved by the purchaser.

12.3.3 For ultrasonic examination of welds, plates and forgings, the purchaser shall be supplied with a report providing diagrams of the surfaces scanned and indications obtained, the areas repaired, the nature of defects repaired, and the repair procedures used.

12.3.4 Magnetic-particle examination shall be performed on all pressure-containing plate edges and openings before welding. Any defects found shall be removed and any necessary repairs performed. Liquid penetrant examination shall be substituted for non-magnetic materials.

12.3.5 Magnetic-particle examination shall be performed on all pressure-retaining welds and weld repairs, after PWHT. If accessible, the back side of the root pass shall be examined after being prepared for final welding. Both sides of accessible completed welds shall be examined. Liquid penetrant examination shall be substituted for non-magnetic materials.

12.3.6 Magnetic-particle examination shall be performed on all pressure-boundary attachment welds.

12.3.7 Magnetic-particle examination shall be performed on areas where temporary lugs have been removed. These areas shall be prepared by grinding them before the examination. Penetrant test can be substituted.

12.3.8 After the hydrostatic test, a magnetic-particle examination shall be performed on all external pressure-retaining welds and all internal nozzle welds that are accessible without disassembling the heat exchanger.

12.3.9 Welds subject to full radiography that cannot be radiographed shall be ultrasonically examined.

12.3.10 Full radiographic examination shall be performed on all pressure-retaining butt welds

12.3.11 Ultrasonic examination shall be performed on all pressure-retaining butt welds [for components over 50 mm (2 in) thick] after post-weld heat treatment. Ultrasonic examination shall comply with the pressure design code. The entire volume of deposited weld metal shall be examined from two directions. Before the welds are examined, the adjacent base material shall be examined by means of longitudinal beam with a

100 % scan for a distance of twice the plate thickness back from the weld. A diagram shall be prepared indicating all areas larger than 12 mm (1/2 in) in diameter that show a loss of back-reflection of 50 % or more. The acceptance criteria shall be agreed upon by the purchaser and the vendor.

Annex A (informative)

Recommended practices

A.1 General

This annex has been prepared to give advice to the designer. The advice is offered for guidance only.

The descriptions and the numbers following are those of subclauses of the main body of this International Standard.

A.2 Design

A.2.1 Cyclic design — Guidance to 7.3

A.2.1.1 The following is guidance to assist in identifying a potential cyclic service application:

- 20 % variance in normal operating pressure, and/or;
- 20 % variance in process flow rate, and/or;
- variation in normal operating temperature that exceeds 110 °C (200 °F).

One cycle is where the variance occurs within a time frame of less than 24 h and the number of cycles exceeds 12 per year.

NOTE The variation in the normal operating temperature is suggested by API 571, Section 4.2.9.3.c, Thermal Fatigue.

A.2.1.2 For assistance in specifying cyclic conditions, it is suggested that the purchaser follow the guidance of ASME BPVC, Section VIII, Division 2, and complete a User Design Specification. Methodologies are also available in other pressure design codes, including EN 13445 (all parts).

A.2.1.3 The vendor can use the screening method provided in ASME BPVC, Section VIII, Division 2, to determine whether a fatigue analysis is required for the given cyclic loading. If required, rules for performing a full fatigue analysis are included. Methodologies are also available in other pressure design codes including EN 13445 (all parts).

A.3 Fabrication

A.3.1 Heat treatment — Guidance to 9.4

U-bends formed from tube materials having low ductility or materials that are susceptible to work hardening can require special consideration. If cold working induces embrittlement or susceptibility to stress corrosion in some materials or environments, then heat treatment should be considered.

A.4 Inspection and testing

A.4.1 Quality assurance — Guidance to 10.1

The purchaser shall specify the required degree of involvement, for example:

- a) verification that qualified welding procedures and qualified welders and welding operators are being used by the manufacturer;
- b) verification that the construction complies with the applicable drawings and with this International Standard;
- c) review and/or examination of the results of any specified non-destructive examination;
- d) witnessing of hydrostatic testing and any additional testing specified by the purchaser;
- e) examination of required material certificates and the manufacturer's data reports.

A.5 Preparation for shipment protection

A.5.1 Protection — Guidance to 11.1

A.5.1.1 If water residues cannot be tolerated, equipment should be dried by one of the following methods:

- a) blowing dry air or nitrogen, of relative humidity less than 15 % (usually dehumidified), through the heat exchanger and monitoring the outlet air until the relative humidity falls below 30 %;
- b) evacuating the heat exchanger with a vacuum pump to an absolute pressure of between 0,4 kPa (0,06 psi) and 0,5 kPa (0,075 psi).

A.5.1.2 After draining and drying, internal surfaces can be protected against corrosion by the addition of a desiccant (e.g. silica gel), by the addition of a volatile corrosion inhibitor, or by blanketing with an inert gas such as nitrogen [typically at a gauge pressure of up to 100 kPa (15 psi)].

Annex B
(informative)

Hairpin heat exchanger checklist

The checklist (Table B.1) is used to record the specific requirements the purchaser makes in response to the clauses and subclauses in this International Standard alongside which bullets (●) are used to indicate that more information is required or it is necessary to make a decision.

Completion of the checklist is the responsibility of the purchaser.

Table B.1 — Checklist for hairpin heat exchangers

Subclause	Requirement	Item		
4.1	Pressure design code	Define code requirements		
4.4	Applicable local regulations			
4.7	Specify if the unit subject to sour service	Yes	No	
6.2.3	Copies required of applicable welding procedure specifications, procedure qualifications and weld map	For review	For record	Not required
6.2.4 a)	Copies required of mechanical design calculations for non-proprietary pressure-retaining components	For review	For record	Not required
6.2.4 b)	Minimum required thicknesses for all pressure-retaining components	For review	For record	Not required
6.2.4 c)	Copies required of maximum allowable working pressure calculations	For review	For record	Not required
6.2.4 d)	Copies required of design calculations based on seismic, wind, transportation and/or piping loads	For review	For record	Not required
6.2.4 e)	Copies required of proposed procedures for assembly of flanged joints and required lubricants	For review	For record	Not required
6.2.4 f)	Copies required of design calculations for thermal loads imposed on nozzles of stacked heat exchangers	For review	For record	Not required
6.2.4 g)	Copies required of flow-induced vibration analysis	For review	For record	Not required
6.2.5 h)	CMTR for all carbon steel materials in contact with the process fluid	For review	For record	Not required
6.3	Format and quantities for the listed final documents			
7.1.1	Maximum design temperature and a minimum design metal temperature (MDMT)			
7.3.1	Specify if hot or cold side subject to cyclic service.			
7.3.2	If cyclic service is specified, specify the variation, the time for the variation and the number of cycles or frequency.			
7.3.3	If cyclic service is specified, define the type of analysis required.			

Table B.2 (continued)

Subclause	Requirement	Item	
		Yes	No
7.7.1.5	Has hairpin exchanger been selected to mitigate a complete tube rupture scenario?	Yes	No
7.7.1.6	Is there a maximum allowable length of straight tube? if so specify.		
7.8.8	Insulation thickness		
7.8.11	Are chemical cleaning connections required?	Yes	No
7.11.6	Will powered bolt-tensioning or torquing device be used in the field? Clarify if the use is for nozzles and/or girth flanges. Type of equipment or the required space	Yes	No
8.2.3	For carbon steel materials in sulfide stress cracking service, the maximum allowable carbon equivalent shall be agreed, including restrictions on other residual elements and micro-alloying elements.		
9.3.10	For carbon steel in sour or wet hydrogen sulfide service, specify if weld procedure qualifications shall include a micro-hardness survey. Specify any additional restrictions on residual elements or micro-alloying elements for the qualification test material.	Yes	No
9.4.2	Requirements for heat treatment after bending for the bend portion of U-tubes		
9.4.4	Is heat treatment required for process reasons?	Yes	No
9.4.5	Is post-weld heat treatment required for weld-overlaid components?	Yes	No
10.1.1	Is information on vendor's quality control system required? Does this include a quality control plan?	Yes	No
10.2.3	Is it required to hardness test the weld metal of pressure-retaining welds in carbon steel components?	Yes	No
10.2.14	Is it required that all carbon steel plate be subjected to an ultrasonic lamination check?	Yes	No
10.3.6	Any additional requirements for equipment drying or preservation		
11.1.7	Any additional requirements for surface preparation and protection		
11.1.9	Is an inert gas purge and fill required?	Yes	No
12.1	Are the additional requirements specified in Clause 12 required? If so, shall they be applied to one or both sides of the heat exchanger?		

Annex C (informative)

Hairpin heat exchanger data sheets

The following data sheets are provided to assist the designer, vendor and purchaser to specify the data necessary for the design of a hairpin heat exchanger for petroleum, petrochemical and natural gas services. Entries that are not relevant to hairpin exchangers should be annotated as N/A.

Completion of the data sheet is a joint responsibility of the purchaser and vendor. The purchaser (owner or contractor) is responsible for the process data, which define the purchaser's explicit requirements.

After the exchanger has been fabricated, the vendor should complete the data sheets to make a permanent record that accurately describes the equipment "as-built".

Additional data sheets can be required to define the hairpin heat exchanger and examples are included in Figures C.1 and C.2.

- Connection schedule (see page 2 of Figures C.1 and C.2), materials of construction (see page 2 of Figures C.1 and C.2); gaskets (see page 2 of Figures C.1 and C.2). These are used if the designer/user requires such level of detail to define materials for individual components. These sections might not be necessary if page one defines the information sufficiently.
- Additional remarks, sketches, etc. (see page 3 of Figures C.1 and C.2). These are used for additional remarks if sufficient space is not available on page 1 and also for schematic sketches to illustrate required features of the design and tube layouts, if necessary, to provide this information to the manufacturer.
- Additional process information (see page 4 of Figures C.1 and C.2). One or two pages can be necessary if boiling and/or condensing fluids with ranges of physical properties occur.
- Additional cyclic service design data (see page 5 of Figures C.1 and C.2). This is required only for exchangers where the unit is subject to cyclic service.

Company		HAIRPIN HEAT EXCHANGER DATA SHEET (SI UNITS)		Engineering contractor	
P.O. No.:		Doc. No.:		Page 1 of	
1	Client:		Location:		
2	Process unit:		Item No.:		
3	Job No.:		Fabricator:		
4	Service of unit:		No. of units:		
5	Size:	Type: double-pipe/pipe-in-pipe/multi-tube	Connected in:	Parallel	Series
6	Effective heat transfer area per unit (plain/finned):		m ²	Shells/unit:	Effective heat transfer area per shell: m ²
7	Performance of one unit		Shell side		Tube side
8			Inlet	Outlet	Inlet Outlet
9	Fluid name:				
10	Fluid quantity, total:	kg/h			
11	Vapour (relative molecular mass):	kg/h			
12	Liquid:	kg/h			
13	Steam:	kg/h			
14	Water:	kg/h			
15	Non-condensable (relative molecular mass):	kg/h	/		
16	Temperature:		°C		
17	Density (vapour/liquid):	kg/m ³			
18	Viscosity (vapour/liquid):	mPa·s			
19	Specific heat (vapour/liquid):	kJ/(kg·K)			
20	Thermal conductivity (vapour/liquid):	W/(m·K)			
21	Specific latent heat:	kJ/kg @ °C	@		@
22	Inlet pressure:	kPa (ga)			
23	Velocity:	m/s			
24	Pressure drop (allowable/calculated):	kPa	/		
25	Fouling resistance:	m ² ·K/W			
26	Average film coefficient:	W/(m ² ·K)			
27	Heat exchanged:	kW	Mean temperature difference (MTD):		°C corrected/weighted
28	Heat transfer rate:	W/(m ² ·K)	Required:	Fouled:	Clean:
29	Rho-V ² :	kg/(m ² ·s ²)	Inlet nozzle:	Bundle entrance:	Bundle exit:
30	Construction per shell				
31	Tube number:	OD: mm	Nozzles – Number, size and rating		
32	Tube wall thickness:	mm	minimum wall/average wall		Shell side Tube side
33	Tube pitch:	mm	Tube layout:	Inlet:	
34	Tube length:	m	Tube type: plain/finned/other	Outlet:	
35	Tube to tubesheet joint:		Intermediate:		
36	Shell diameter:	mm (ID/OD)	/	Vent:	
37	Cross-baffle type:		Drain:		
38	Baffle spacing: c/c	mm	No. of cross passes:	Pressure relief:	
39	Baffle cut:	%	vertical/horizontal	Design pressure:	kPa (ga)
40	Tube support type:		Vacuum: kPa (abs)		
41	Tube closure type:		Design temp. (Max/MDMT): °C / /		
42	Impingement protection:	(Y/N)	Type:	Corrosion allowance: mm	
43	Materials of construction				
44	Shell:	Tubes:		Gaskets	
45	Shell cover:		Shell side:		
46	Channel or bonnet:		Tube side:		
47	Channel cover:		Floating head:		
48	Floating head cover/bolts:		Spare gaskets required:		
49	Tubesheet: Stationary:	Floating:		Test ring required: (Y/N)	
50	Baffles: Cross:	Longitudinal:		Insulation - shell: mm	
51	Tube support material:		Insulation - channel: mm inlet/outlet		
52	Expansion joint type:		Expansion joint material:		
53	Pressure design code:	Stamp:	Calculate MAWP: (Y/N)	TEMA Class:	
54	Remarks/sketch:				
55					
56					
57					
Rev. No.	Description	Date	Prepared by	Reviewed by	

Figure C.1 — Hairpin exchanger data sheet — SI units

Company	HAIRPIN HEAT EXCHANGER CONNECTIONS AND MATERIALS DATA SHEET (SI UNITS)	Engineering contractor					
P.O. No.:	Doc. No.:	Page 2 of					
1 Client:	Location:						
2 Process unit:	Item No.:						
3 Job No.:	Fabricator:						
4 Connection schedule (optional)							
	Mark	Number required	Size	Rating	Facing	Description	
5							
6							
7							
8							
9							
10							
11							
12							
13							
14							
15							
16							
17 Materials of construction (optional)						Corrosion allowance	
18 Shell:						mm	
19 Head:						mm	
20 Pipe/stub ends:						mm	
21 Nozzle necks:						mm	
22 Nozzle flanges:						mm	
23 Body flanges:						mm	
24 Expansion joint:						mm	
25 Support:						mm	
26 Bolting (internal):						mm	
27 Bolting (external):						mm	
28 Nozzle reinforcement:						mm	
29 Tubes:							
30 Tubesheets:						mm	
31 Bonnet/channel:						mm	
32 Bonnet head(s):						mm	
33 Channel cover(s):						mm	
34 Body flanges:						mm	
35 Pipe/stub ends:						mm	
36 Bolting (internal):						mm	
37 Bolting (external):						mm	
38 Nozzle reinforcement:						mm	
39 Nozzle necks:						mm	
40 Nozzle flanges:						mm	
41 Baffles, spacers, tie rods:						mm	
42							
43							
44							
45							
46							
Gaskets (optional)			Mechanical data (optional)				
48 Shell side:	Thickness:	mm	MAWP (hot and corroded): kPa (ga)				
49 Y =	Pa	m =	MAP (new and cold): kPa (ga)				
50 Tube side:	Thickness:	mm	Hydrotest pressure:				
51 Y =	Pa	m =	Field:	kPa (ga)	Shop:	kPa (ga)	
52 Floating head:	Thickness:	mm	Mass:	Empty:	kg	Bundle:	kg
53 Y =	Pa	m =	Full of water: kg				
Rev. No.	Revision	Date	Prepared by	Reviewed by			

Figure C.1 (continued)

Company	HAIRPIN EXCHANGER ADDITIONAL INFORMATION DATA SHEET (SI UNITS)	Engineering contractor
P.O. No.:	Doc. No.:	Page 3 of

1	Client:	Location:
2	Process unit:	Item No.:
3	Job No.:	Fabricator:

Additional remarks, sketches, etc. (optional)

Rev. No.	Revision	Date	Prepared by	Review ed by
----------	----------	------	-------------	--------------

Figure C.1 (continued)

Company	HAIRPIN HEAT EXCHANGER ADDITIONAL PROCESS INFORMATION DATA SHEET (SI UNITS)	Engineering contractor
P.O. No.:	Doc. No.:	Page 4 of

1 Client:	Location:
2 Process unit:	Item No.:
3 Job No.:	Fabricator:

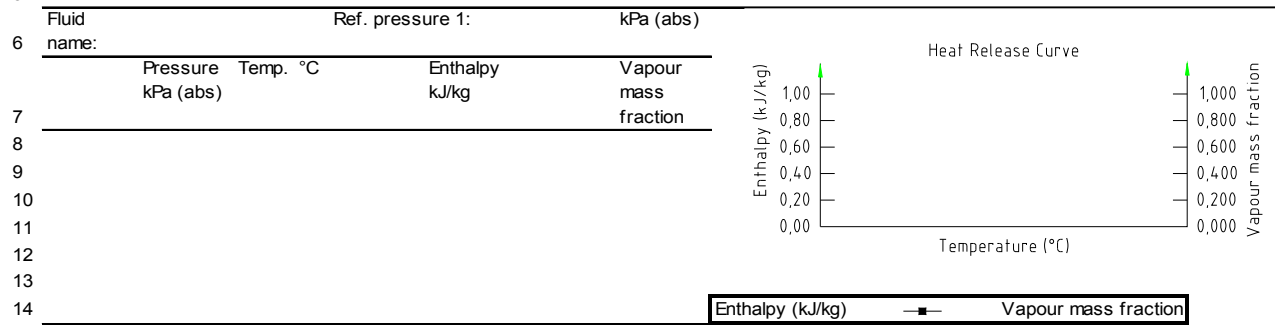

Density vapour	Density liquid	Viscosity vapour	Viscosity liquid	Thermal conductivity vapour	Thermal conductivity liquid	Specific heat vapour	Specific heat liquid	Surface tension	Liquid critical pressure	Liquid critical temp.
kg/m ³	kg/m ³	mPa·s	mPa·s	W/m·K	W/m·K	kJ/(kg·K)	kJ/(kg·K)	N/m	kPa (abs)	°C

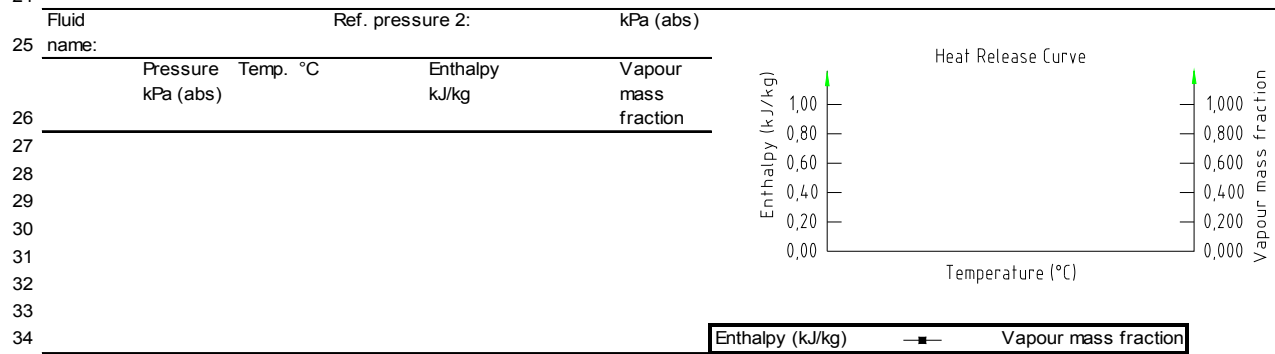

Density vapour	Density liquid	Viscosity vapour	Viscosity liquid	Thermal conductivity vapour	Thermal conductivity liquid	Specific heat vapour	Specific heat liquid	Surface tension	Liquid critical pressure	Liquid critical temp.
kg/m ³	kg/m ³	mPa·s	mPa·s	W/m·K	W/m·K	kJ/(kg·K)	kJ/(kg·K)	N/m	kPa (abs)	°C

Rev. No.	Revision	Date	Prepared by	Review ed by
----------	----------	------	-------------	--------------

Figure C.1 (continued)

Company	HAIRPIN EXCHANGER ADDITIONAL INFORMATION DATA SHEET (SI UNITS)	Engineering contractor
P.O. No.:	Doc. No.:	Page 5 of

1 Client:	Location:
2 Process unit:	Item No.:
3 Job No.:	Fabricator:

Description of Cyclic Service Operation

	Condition	Time h/m	Duration h/m	Composition	Flow rate kg/h
7					
8					
9					
10					
11					
12					
13					
14					
15					
16					
17					
18					
19					
20					
21					
22					
23					
24					
25					

	Condition	Time h/m	Duration h/m	Temperature °C	Pressure kPa(g)
28					
29					
30					
31					
32					
33					
34					
35					
36					
37					
38					
39					
40					
41					
42					
43					
44					
45					
46					

48 **NOTES:**

49
50
51
52
53
54

Rev. No.	Revision	Date	Prepared by	Reviewed by
----------	----------	------	-------------	-------------

Figure C.1(continued)

Company		HAIRPIN EXCHANGER DATA SHEET (US CUSTOMARY UNITS)		Engineering contractor	
P.O. No.:		Doc. No.:		Page 1 of	
1	Client:		Location:		
2	Process unit:		Item No.:		
3	Job No.:		Fabricator:		
4	Service of unit:		No. of units:		
5	Size:	Type: double-pipe/pipe-in-pipe/multi-tube	Connected in: Parallel		Series
6	Effective heat transfer area per unit (plain/finned): ft ²		Shells/unit:	Effective heat transfer area per shell: ft ²	
7	Performance of one unit		Shell side		Tube side
8			Inlet	Outlet	
9	Fluid name:	lb/h			
10	Fluid quantity, total:	lb/h			
11	Vapour (relative molecular mass):	lb/h			
12	Liquid:	lb/h			
13	Steam:	lb/h			
14	Water:	lb/h			
15	Non-condensable / relative molecular mass:	lb/h	/		/
16	Temperature:	°F			
17	Density (vapour/liquid):	lb/ft ³			
18	Viscosity (vapour/liquid):	cP			
19	Specific heat (vapour/liquid):	Btu/(lb·°F)			
20	Thermal conductivity (vapour/liquid):	Btu/(h·ft·°F)			
21	Specific latent heat:	Btu/lb @ °F	@		@
22	Inlet pressure:	psig			
23	Velocity:	ft/s			
24	Pressure drop (allowable/calculated):	psi	/		/
25	Fouling resistance:	h·ft ² ·°F/Btu			
26	Average film coefficient:	Btu/(h·ft ² ·°F)			
27	Heat exchanged:	Btu/h	Mean temperature difference (MTD): °F corrected/w eighted		
28	Heat transfer rate:	Btu/(h·ft ² ·°F)	Required:	Fouled:	Clean:
29	Rho·V ² :	lb/(ft·s ²)	Inlet nozzle:	Bundle entrance:	Bundle exit:
30	Construction per shell				
31	Tube number:	OD: in	Nozzles – Number, size and rating		
32	Tube wall thickness:	in	minimum wall/average wall	Shell side	Tube side
33	Tube pitch:	in	Tube layout:	Inlet:	
34	Tube length:	ft	Tube type: plain/finned/other	Outlet:	
35	Tube to tubesheet joint:			Intermediate:	
36	Shell diameter:	in (ID/OD)	/	Vent:	
37	Cross-baffle type:			Drain:	
38	Baffle Spacing: c/c	in	No. of cross passes:	Pressure relief:	
39	Baffle Cut:	%	vertical/horizontal	Design pressure:	psig
40	Tube support type:			Vacuum:	psia
41	Tube closure type:			Design temp. (Max/MDMT):	°F / /
42	Impingement protection: (Y/N)	Type:		Corrosion allowance:	in
43	Materials of construction				
44	Shell:	Tubes:	Gaskets		
45	Shell cover:		Shell side:		
46	Channel or bonnet:		Tube side:		
47	Channel cover:		Floating head:		
48	Floating head cover/bolts:		Spare gaskets required:		
49	Tubesheet: Stationary:	Floating:		Test ring required:	(Y/N)
50	Baffles: Cross:	Longitudinal:		Insulation - shell:	in
51	Tube support material:			Insulation - channel:	in inlet/outlet
52	Expansion joint type:			Expansion joint material:	
53	Pressure design code:	Stamp:	Calculate MAWP:	(Y/N)	TEMA Class:
54	Remarks/sketch:				
55					
56					
57					
Rev. No.	Revision	Date	Prepared by	Reviewed by	

Figure C.2 — Hairpin exchanger data sheet — USC units

Company	HAIRPIN HEAT EXCHANGER CONNECTIONS AND MATERIALS DATA SHEET (US CUSTOMARY UNITS)	Engineering contractor
P.O. No.:	Doc. No.:	Page 2 of
1 Client:	Location:	
2 Process unit:	Item No.:	
3 Job No.:	Fabricator:	
4 Connection schedule (optional)		
	Mark	Number required
	Size	Rating
	Facing	Description
5		
6		
7		
8		
9		
10		
11		
12		
13		
14		
15		
16		
17 Materials of construction (optional)	Corrosion allowance	
18 Shell:	in	
19 Head:	in	
20 Pipe/stub ends:	in	
21 Nozzle necks:	in	
22 Nozzle flanges:	in	
23 Body flanges:	in	
24 Expansion joint:	in	
25 Support:	in	
26 Bolting (internal):	in	
27 Bolting (external):	in	
28 Nozzle reinforcement:	in	
29 Tubes:		
30 Tubesheets:	in	
31 Bonnet/channel:	in	
32 Bonnet head(s):	in	
33 Channel cover(s):	in	
34 Body flanges:	in	
35 Pipe/stub ends:	in	
36 Bolting (internal):	in	
37 Bolting (external):	in	
38 Nozzle reinforcement:	in	
39 Nozzle necks:	in	
40 Nozzle flanges:	in	
41 Baffles, spacers, tie rods:	in	
42		
43		
44		
45		
46		
47	Gaskets (optional)	Mechanical data (optional)
48 Shell side: Thickness:	in	MAWP (hot and corroded): psig
49 Y = psi	m =	MAP (new and cold): psig
50 Tube side: Thickness:	in	Hydrotest pressure:
51 Y = psi	m =	Field: psig Shop: psig
52 Floating head: Thickness:	in	Mass: Empty: lb Bundle: lb
53 Y = psi	m =	Full of water: lb
Rev. No.	Revision	Date
		Prepared by
		Review ed by

Figure C.2 (continued)

Company	HAIRPIN HEAT EXCHANGER ADDITIONAL INFORMATION DATA SHEET (US CUSTOMARY UNITS)	Engineering contractor
P.O. No.:	Doc. No.:	Page 3 of

1	Client:	Location:
2	Process unit:	Item No.:
3	Job No.:	Fabricator:

Additional remarks, sketches, etc. (optional)

Rev. No.	Revision	Date	Prepared by	Review ed by
----------	----------	------	-------------	--------------

Figure C.2 (continued)

Company	HAIRPIN HEAT EXCHANGER ADDITIONAL PROCESS INFORMATION DATA SHEET (US CUSTOMARY UNITS)	Engineering contractor
P.O. No.:	Doc. No.:	Page 4 of

1 Client:	Location:
2 Process unit:	Item No.:
3 Job No.:	Fabricator:

6 Fluid name:	Ref. pressure 1:	psi (abs)
---------------	------------------	-----------

7 Pressure psi (abs)	Temp. °F	Enthalpy Btu/lb	Vapour mass fraction
-------------------------	----------	--------------------	----------------------------

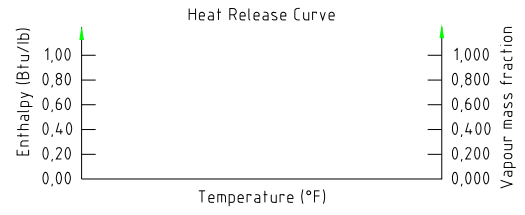

16 Density vapour	Density liquid	Viscosity vapour	Viscosity liquid	Thermal conductivity vapour	Thermal conductivity liquid	Specific heat vapour	Specific heat liquid	Surface tension	Liquid critical pressure	Liquid critical temp.
lb/ft³	lb/ft³	cP	cP	Btu/(h·ft·°F)	Btu/(h·ft·°F)	Btu/(lb·°F)	Btu/(lb·°F)	dyne/cm	psia	°F

25 Fluid name:	Ref. pressure 2:	psi (abs)
----------------	------------------	-----------

26 Pressure psi (abs)	Temp. °F	Enthalpy Btu/lb	Vapour mass fraction
--------------------------	----------	--------------------	----------------------------

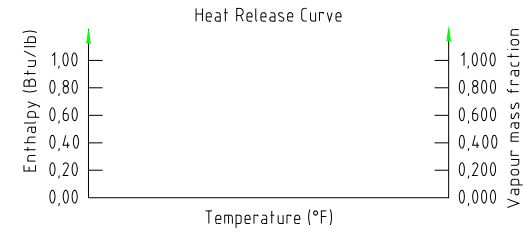

36 Density vapour	Density liquid	Viscosity vapour	Viscosity liquid	Thermal conductivity vapour	Thermal conductivity liquid	Specific heat vapour	Specific heat liquid	Surface tension	Liquid critical pressure	Liquid critical temp.
lb/ft³	lb/ft³	cP	cP	Btu/(h·ft·°F)	Btu/(h·ft·°F)	Btu/(lb·°F)	Btu/(lb·°F)	dyne/cm	psia	°F

Rev. No.	Revision	Date	Prepared by	Review ed by
----------	----------	------	-------------	--------------

Figure C.2 (continued)

Company	HAIRPIN EXCHANGER ADDITIONAL INFORMATION DATA SHEET (US CUSTOMARY UNITS)	Engineering contractor
P.O. No.:	Doc. No.:	Page 5 of

1 Client:	Location:
2 Process unit:	Item No.:
3 Job No.:	Fabricator:

Description of Cyclic Service Operation

	Condition	Time h/m	Duration h/m	Composition	Flow rate lb/h
9					
10					
11					
12					
13					
14					
15					
16					
17					
18					
19					
20					
21					
22					
23					
24					
25					

	Condition	Time h/m	Duration h/m	Temperature °F	Pressure psig
30					
31					
32					
33					
34					
35					
36					
37					
38					
39					
40					
41					
42					
43					
44					
45					
46					

48 **NOTES:**

49

50

51

52

53

54

Rev. No.	Revision	Date	Prepared by	Review ed by
----------	----------	------	-------------	--------------

Figure C.2 (continued)

Bibliography

- [1] EN 10160⁴⁾, *Ultrasonic testing of steel flat product of thickness equal or greater than 6 mm (reflection method)*
- [2] EN 13445 (all parts), *Unfired pressure vessels*
- [3] ASME *Boiler and Pressure Vessel Code (BPVC), Section VIII, Rules for construction of pressure vessels*
- [4] ASME *Boiler and Pressure Vessel Code (BPVC), Section VIII, Rules for construction of pressure vessels, Division 2, Alternative Rules*
- [5] ASME B16.11, *Forged Fittings, Socket-Welding and Threaded*
- [6] ASME B1.20.1, *Pipe Threads, General Purpose (Inch)*
- [7] WRC 537⁵⁾, *Local Stresses in Spherical and Cylindrical Shells Due To External Loading*
- [8] ASTM B359/B359M, *Standard Specification for Copper and Copper-Alloy Seamless Condenser and Heat Exchanger Tubes with Integral Fins*
- [9] NACE MR0175, *Petroleum and Natural Gas Industries — Materials for Use in H₂S-containing Environments in Oil and Gas Production — Parts 1, 2 and 3*
- [10] API Std 521, *Pressure-relieving and Depressuring Systems*
- [11] API RP 571, *Damage Mechanisms Affecting Fixed Equipment in The Refining Industry*
- [12] ASME SA-578, *Specification for Straight-Beam Ultrasonic Examination of Plain and Clad Steel Plates for Special Applications*

4) Comité Européen de Normalization, 36, rue de Stassart, B-1050 Brussels, Belgium.

5) Welding Research Council, Park Avenue, 27th Floor, New York, New York, NY 10016-5902, USA.

