**Paper and board — Determination of
compressive strength — Ring crush
method**

*Papier et carton — Détermination de la résistance à la compression —
Méthode d'écrasement en anneau*



Reference number
ISO 12192:2011(E)

© ISO 2011



COPYRIGHT PROTECTED DOCUMENT

© ISO 2011

All rights reserved. Unless otherwise specified, no part of this publication may be reproduced or utilized in any form or by any means, electronic or mechanical, including photocopying and microfilm, without permission in writing from either ISO at the address below or ISO's member body in the country of the requester.

ISO copyright office
Case postale 56 • CH-1211 Geneva 20
Tel. + 41 22 749 01 11
Fax + 41 22 749 09 47
E-mail copyright@iso.org
Web www.iso.org

Published in Switzerland

Contents

Page

Foreword	iv
Introduction	v
1 Scope	1
2 Normative references	1
3 Terms and definitions	1
4 Principle	2
5 Apparatus	2
6 Sampling	4
7 Conditioning	4
8 Preparation of test pieces	4
9 Procedure	4
10 Calculation of results	5
10.1 Ring crush resistance	5
10.2 Ring-crush-resistance index	6
11 Test report	6
Annex A (informative) Precision	7
Bibliography	10

Foreword

ISO (the International Organization for Standardization) is a worldwide federation of national standards bodies (ISO member bodies). The work of preparing International Standards is normally carried out through ISO technical committees. Each member body interested in a subject for which a technical committee has been established has the right to be represented on that committee. International organizations, governmental and non-governmental, in liaison with ISO, also take part in the work. ISO collaborates closely with the International Electrotechnical Commission (IEC) on all matters of electrotechnical standardization.

International Standards are drafted in accordance with the rules given in the ISO/IEC Directives, Part 2.

The main task of technical committees is to prepare International Standards. Draft International Standards adopted by the technical committees are circulated to the member bodies for voting. Publication as an International Standard requires approval by at least 75 % of the member bodies casting a vote.

Attention is drawn to the possibility that some of the elements of this document may be the subject of patent rights. ISO shall not be held responsible for identifying any or all such patent rights.

ISO 12192 was prepared by Technical Committee ISO/TC 6, *Paper, board and pulps*, Subcommittee SC 2, *Test methods and quality specifications for paper and board*.

This second edition cancels and replaces the first edition (ISO 12192:2002), which has been technically revised. In the revision, the instrument is clarified in accordance with ISO 13820, relevant terms are defined, a precision statement is added, and other minor text corrections have been made. Significant technical changes in this revision include an expansion of the scope of the method to thinner specimens (lower grammage) and a clarification of the procedure to indicate testing with alternating sides of the test piece facing outward.

Introduction

Fibreboard shipping containers are frequently subjected to in-plane compressive forces during shipment or storage. Therefore, resistance to crushing is an important measure of the performance characteristics of the containers.

The resistance to crushing depends on the design of the containers and on the in-plane crush resistance of the components of the board from which it is made. The in-plane crush resistance of these components can be measured by the ring crush test.

© ISO 2011. All rights reserved.

Paper and board — Determination of compressive strength — Ring crush method

1 Scope

This International Standard specifies a method for the determination of the edgewise compressive strength (ring crush resistance) of paper and paperboard, especially board used in the manufacture of fibreboard shipping containers.

This International Standard is applicable to all paper and paperboard with a thickness in the range 100 μm to 580 μm . For samples having a thickness below 280 μm , test values can result from a combination of both buckling failure and pure compression.

NOTE For samples having a thickness exceeding 580 μm , strain within the sample arising from bending the test piece into a cylinder might affect the test result (see References [6] and [7] in the Bibliography).

2 Normative references

The following referenced documents are indispensable for the application of this document. For dated references, only the edition cited applies. For undated references, the latest edition of the referenced document (including any amendments) applies.

ISO 186, *Paper and board — Sampling to determine average quality*

ISO 187, *Paper, board and pulps — Standard atmosphere for conditioning and testing and procedure for monitoring the atmosphere and conditioning of samples*

ISO 534, *Paper and board — Determination of thickness, density and specific volume*

ISO 13820, *Paper, board and corrugated fibreboard — Description and calibration of compression-testing equipment*

3 Terms and definitions

For the purposes of this document, the following terms and definitions apply.

3.1

compressive strength

maximum compressive force per unit length that a test piece of paper or board can withstand until the onset of failure

NOTE The compressive strength is expressed in kilonewtons per metre.

3.2

ring crush resistance

maximum compressive force per unit length that a narrow test piece bent into the form of a cylinder (ring) can withstand on its edge without failure under the conditions defined in this International Standard

NOTE The ring crush resistance is expressed in kilonewtons per metre.

3.3

ring-crush-resistance index

ring crush resistance divided by the grammage

NOTE The ring-crush-resistance index is expressed in kilonewton metres per gram.

4 Principle

A test piece of paper or board, in the form of a narrow strip held in a ring form, is subjected to an increasing edgewise compressive force until the onset of collapse.

The ring crush resistance is calculated from the maximum compressive force and the length of the test piece.

5 Apparatus

5.1 Cutting device, consisting of a die cutter, capable of accurately cutting the test pieces to the specified dimensions with clean, sharp, parallel and straight edges. Other cutting devices, such as a double-knife cutter, may be used provided they can be shown to give similar test results.

5.2 Test-piece holder (see Figure 1), consisting of a base block (item 1 in Figure 1), preferably cylindrical, having a cylindrical recession which, together with a removable central disc (item 3 in Figure 1), forms an annular groove (item 5 in Figure 1).

The recession shall have an inside diameter of $49,30 \text{ mm} \pm 0,05 \text{ mm}$ and be $6,35 \text{ mm} \pm 0,25 \text{ mm}$ deep with its bottom parallel to the base of the block to within $0,01 \text{ mm}$. The disc (item 3 in Figure 1) is $6,35 \text{ mm} \pm 0,25 \text{ mm}$ thick. To accommodate test pieces of various thicknesses, discs of various diameters shall be provided, so that the width of the groove (item 5 in Figure 1) formed between the edge of the disc and the wall of the cylindrical recess may be adjusted to be at least 150 %, but not more than 175 %, of the calliper of the test piece being tested. Suitable disc diameters are given in Table 1.

A centring pin (item 4 in Figure 1) is fixed in the exact centre of the cylindrical recess. The pin can be recessed from the base of the block but shall not protrude from the bottom. Each disc shall have a hole of slightly larger diameter at its exact centre to accommodate the pin, which will then correctly centralize the disc and provide a uniform annular groove.

Dimensions in millimetres

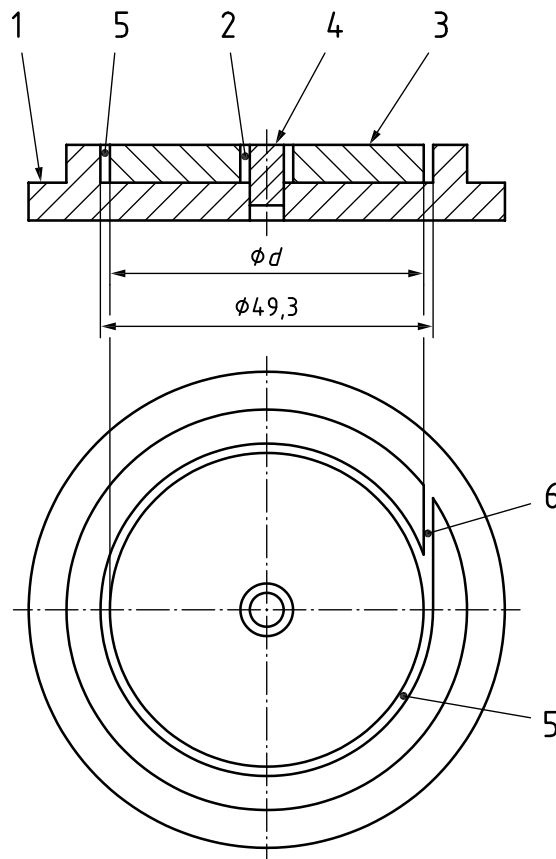
**Key**

- 1 base block
- 2 gap to allow discs to revolve freely
- 3 disc
- 4 centring pin
- 5 annular groove for test piece
- 6 tangential groove

Figure 1 — Test-piece holder

It is essential that the area of contact between the bottom of the cylindrical recess and its side be a right angle. Any radius at this point prevents the test strip from resting squarely on the bottom and gives rise to erroneous results.

A tangential groove (item 6 in Figure 1) not more than 1,27 mm in width is cut from the edge of the block tangential to the cylindrical recess to permit insertion of the test piece. This groove may be positioned for either clockwise or counter-clockwise insertion.

5.3 Motor-driven, platen-type crush tester, in accordance with ISO 13820 except that the parallelism of the platens shall be within 0,025 mm per 100 mm of surface (1:4 000). The testing machine shall be calibrated in accordance with ISO 13820.

5.4 Cotton or plastic gloves, for use when the test pieces are inserted manually.

6 Sampling

If the tests are being made to evaluate a lot, the sample shall be selected in accordance with ISO 186. If the tests are made on another type of sample, make sure that the specimens taken are representative of the sample received.

7 Conditioning

Condition the samples in accordance with ISO 187 and keep them in the conditioning atmosphere throughout the preparation of test pieces and the testing procedure.

8 Preparation of test pieces

If the ring-crush-resistance index is to be calculated, determine the grammage of the specimens in accordance with ISO 536^[1].

Determine the thickness of the specimens in accordance with ISO 534.

Prepare the test pieces in the same atmosphere as that used to condition the samples. Gloves (5.4) should be worn throughout the sample preparation and testing procedure, as contaminants on hands, particularly moisture, may affect the test results.

Using a cutting device (5.1), carefully cut from the sample, one at a time, test pieces of 12,7 mm ± 0,1 mm in width and 152,4 mm $\begin{matrix} 0 \\ -2,5 \end{matrix}$ mm in length, free from wrinkles, creases or other visible defects likely to influence

the test results. Ensure that the edges are straight and cleanly cut without tears or frays, and are parallel to within 0,015 mm over their length.

Unless otherwise specified, cut at least ten test pieces in each of the required directions. Test pieces with the long dimension perpendicular to the machine direction are used to test the machine-direction crush resistance. Those with the long dimension parallel to the machine direction are used to test the cross-direction crush resistance.

For two-sided specimens in which the fibre compositions of the two sides are different and where the side which will be on the outside of the container can be identified, cut the required number of test pieces with the outside towards the male die, or away from the blades if a double-knife cutter is used. These types of cutters tend to generate small protrusions or a slight curl of the cut edges which, if oriented toward the centre of the ring, can tend to lift the centre disc, causing erroneous readings.

If the sides are indistinguishable or if the outside is not known, cut the same number of test pieces, at least ten, with the same side facing the male die of the die cutter or the blades of the double-knife cutter.

9 Procedure

Place the disc, whose diameter is appropriate to the thickness of the test piece, in the test-piece holder (5.2). The disc shall be selected so that the groove width between the disc and holder is large enough for the test piece to be inserted without resistance but does not exceed 175 % of the mean thickness of the test piece. Table 1 gives an indication of likely suitable disc diameters for test pieces of different thicknesses.

Carefully insert the test piece into the tangential groove and gently guide it into the holder until the free ends are located away from the tangential groove. Place the test pieces in the holder so that half are tested with one side facing inward and half with that same side facing outward. Take care to ensure that the disc does not rise and allow the lower edge of the test piece to get underneath it.

Table 1 — Suitable disc diameters

Thickness of test piece ^a µm	Suggested disc diameter ^a ($d \pm 0,05$) mm
100 to 140	48,90
141 to 170	48,80
171 to 200	48,70
201 to 230	48,60
231 to 280	48,50
281 to 320	48,40
321 to 370	48,20
371 to 420	48,00
421 to 500	47,80
501 to 580	47,60

^a These are merely suggested ranges. The 175 % mentioned above is the controlling factor. If the discs are made to the lower tolerance in some instances, the 175 % may be exceeded, in which case the next smaller groove width shall be used.

Place the test-piece holder on the centre of the lower platen of the crush tester (5.3), if necessary using guide marks or blocks to ensure that the holder is always placed in the same position.

Position the holder, so that the meeting ends of the test piece are always facing left or right prior to testing. Operate the crush tester until the onset of failure and record the maximum force sustained by the test piece prior to failure, to the nearest newton.

Repeat this procedure for the remaining test pieces.

NOTE The ring crush test is extremely sensitive to the moisture content of the paper or board. Knowledge of the moisture content will sometimes help to explain differences in between-laboratory results.

A common source of error is damage to the test pieces during insertion into the holder. When maximum accuracy of the results is required, the use of a mechanical feeder to insert the test piece into the holder is recommended. If such a feeder is used, the use of gloves is optional. Details of a suitable device can be found in Reference [12] in the Bibliography.

10 Calculation of results

10.1 Ring crush resistance

For each of the required directions (machine direction, cross-direction), calculate the mean ring crush resistance, σ , in kilonewtons per metre, from Equation (1):

$$\sigma = \frac{\bar{F}}{l} \quad (1)$$

where

\bar{F} is the mean maximum compressive force, in newtons;

l is the length of the test piece, in millimetres.

For each required direction, report the ring crush resistance, in kilonewtons per metre, to three significant figures. Also calculate and report the standard deviation.

10.2 Ring-crush-resistance index

If required, calculate the ring-crush-resistance index, X , in kilonewton metres per gram, from Equation (2):

$$X = \frac{\sigma}{g} \quad (2)$$

where

- σ is the mean ring crush resistance, in kilonewtons per metre;
- g is the grammage, in grams per square metre, of the conditioned specimens.

Report the ring-crush-resistance index to three significant figures.

11 Test report

The test report shall include the following information:

- a) a reference to this International Standard (ISO 12192:2011);
- b) date and place of testing;
- c) description and identification of the material tested;
- d) conditioning atmosphere used;
- e) type of cutter and compression testing machine used;
- f) thickness of the test piece and diameter of the disc used in the test-piece holder;
- g) number and orientation of replicate tests in each required direction;
- h) whether a mechanical feeder was used;
- i) for each required direction, the mean ring crush resistance, in kilonewtons per metre;
- j) for each required direction, the standard deviation, in kilonewtons per metre;
- k) if required, for each required direction, the ring-crush-resistance index, in kilonewton metres per gram;
- l) any deviation from the procedure described in this International Standard or any other circumstances which may have affected the results.

Annex A (informative)

Precision

A.1 General

Precision data is available from several different international sources, for testing performed using a motor-driven platen crush tester as described in 5.3.

The repeatability and reproducibility limits reported are estimates of the maximum difference which should be expected in 19 out of 20 instances, when comparing two test results for material similar to those described under similar test conditions. These estimates may not be valid for different materials or different test conditions. These calculations were made according to ISO/TR 24498^[3], and TAPPI Test method T 1200 sp-07^[4].

The repeatability standard deviation reported in Tables A.1 and A.3 is the “pooled” repeatability standard deviation that is, the standard deviation is calculated as the root-mean-square of the standard deviations of the participating laboratories. This differs from the conventional definition of repeatability in ISO 5725-1^[2].

Repeatability and reproducibility limits are calculated by multiplying the repeatability and reproducibility standard deviations by 2,77.

NOTE $2,77 = 1,96 \sqrt{2}$, provided that the test results have a normal distribution and that the standard deviation s is based on a large number of tests.

A.2 Precision data from TAPPI-CTS

The estimates of repeatability and reproducibility listed in Tables A.1 and A.2 are based on data from the CTS Containerboard Interlaboratory Program using testing conducted in 2006. The data included either 12 weekly rounds of testing, for 36 lb (approximately 175 g/m²) linerboard and 69 lb (approximately 335 g/m²) linerboard, or 24 weekly rounds of testing, for 26 lb (approximately 126 g/m²) medium and 42 lb (approximately 205 g/m²) linerboard.

The precision estimates are based on ten determinations per test result and one test result per laboratory for each round of testing. For each weekly round, between 57 and 68 (approximately 60) laboratories are included in the calculation of the precision estimates for linerboard, and between 20 and 25 (approximately 20) laboratories are included in the calculation of precision estimates for the corrugating medium. Only laboratories that reported using rigid-platen-type instruments and TAPPI standard conditioning atmospheres are included in the calculations.

Table A.1 — Estimation of repeatability of the test method from TAPPI-CTS

Material	Number of laboratories	Mean value kN/m	Standard deviation s_r kN/m	Coefficient of variation $C_{V,r}$ %	Repeatability limit r kN/m
26 lb medium	~20	1,18	0,06	5,30	0,17
36 lb linerboard	~60	2,20	0,10	4,64	0,28
42 lb linerboard	~60	3,12	0,10	3,19	0,28
69 lb linerboard	~60	4,71	0,14	2,95	0,39

Table A.2 — Estimation of reproducibility of the test method from TAPPI-CTS

Material	Number of laboratories	Mean value kN/m	Standard deviation s_R kN/m	Coefficient of variation $C_{V,R}$ %	Reproducibility limit R kN/m
26 lb medium	~20	1,18	0,27	22,5	0,74
36 lb linerboard	~60	2,20	0,37	16,7	1,02
42 lb linerboard	~60	3,12	0,47	15,1	1,31
69 lb linerboard	~60	4,71	0,64	13,6	1,77

A.3 Precision data from CEPI-CTS

Estimates of repeatability and reproducibility from the CEPI-CTS program is based on round-robin work in 2008. Fifteen laboratories participated, testing three different sample materials. For each material, 13 or 14 laboratories were included in the precision calculation. As with the TAPPI-CTS data, repeatability and reproducibility limits appear to be somewhat dependent on the absolute value of the measurements, with stronger papers (higher measured values) exhibiting slightly lower variability.

When data from CEPI-CTS are used, there is a need to recalculate the data to present the repeatability limits and reproducibility limits.

The repeatability limit, r , can be calculated as: $r = 1,96 \times \sqrt{2} \times s_{\text{within lab}}$.

The reproducibility limit, R , can be calculated as: $R = 1,96 \times \sqrt{2} \times \sqrt{s_{\text{within lab}}^2 + s_{\text{between lab}}^2}$.

Table A.3 — Estimation of repeatability of the test method from CEPI-CTS

Material	Number of laboratories	Mean value kN/m	Standard deviation s_r kN/m	Coefficient of variation $C_{V,r}$ %	Repeatability limit r kN/m
Level 1	14	0,81	0,05	5,61	0,13
Level 2	13	2,01	0,09	4,51	0,25
Level 3	13	3,34	0,15	4,37	0,41

Table A.4 — Estimation of reproducibility of the test method from CEPI-CTS

Material	Number of laboratories	Mean value kN/m	Standard deviation s_R kN/m	Coefficient of variation $C_{V,R}$ %	Reproducibility limit R kN/m
Level 1	14	0,81	0,12	14,7	0,33
Level 2	13	2,01	0,25	12,7	0,70
Level 3	13	3,34	0,41	12,4	1,15

Bibliography

- [1] ISO 536, *Paper and board — Determination of grammage*
- [2] ISO 5725-1, *Accuracy (trueness and precision) of measurement methods and results — Part 1: General principles and definitions*
- [3] ISO/TR 24498, *Paper, board and pulps — Estimation of uncertainty for test methods*
- [4] TAPPI Test method T 1200 sp-07, *Interlaboratory evaluation of test methods to determine TAPPI repeatability and reproducibility*
- [5] DAHL, C.B. JR., Limited Range of Ring Crush Test, *TAPPI J.*, **Vol. 68**, No. 10, 1985, pp. 108-109
- [6] *Effect of specimen dimensions on edgewise compression tests of linerboard and corrugating medium*, Parts 1 and 2, Testing Compression Reports 82 and 83, Institute of Paper Chemistry, Project 1108-4, March 23rd, 1966
- [7] FELLERS, C. and DONNER, B.C., *Edgewise compression strength of paper*, in Handbook of Physical Testing of Paper, **Vol. 1**, Chapter 9, Marcel Dekker Inc., 2nd edition
- [8] FRANK, B., Ring Crush and Short Span Compression for Predicting Edgewise Compressive Strength, *TAPPI J.*, **Vol. 2**, No. 11, 2003, p. 12
- [9] KONING, J.W., A short column crush test of corrugated paperboard, *TAPPI J.*, **Vol. 47**, No. 3, 1964, p. 134
- [10] SMITH, J.H., *A discussion of the ring crush test*, Southern Pulp & Paper Manufacturer, August 11, 1958
- [11] STORA TEKNIK, SE-661 00 SÄFFLE, Sweden — PM 223/189 TKS 1989-02-06, *Study — A comparison between different compression testers and cutting devices used in BILLERUD comparative testing*
- [12] TRAVERS, R., Improving the reliability of the ring crush test, *Appita*, **Vol. 30**, No. 3, 1976, pp. 235-240

© ISO 2015

ICS 85.060

Price based on 10 pages