**Road vehicles — Endurance braking
systems of motor vehicles and towed
vehicles — Test procedures**

*Véhicules routiers — Véhicules à moteur et véhicules tractés disposant
de systèmes de freinage d'endurance — Procédures d'essai*



PDF disclaimer

This PDF file may contain embedded typefaces. In accordance with Adobe's licensing policy, this file may be printed or viewed but shall not be edited unless the typefaces which are embedded are licensed to and installed on the computer performing the editing. In downloading this file, parties accept therein the responsibility of not infringing Adobe's licensing policy. The ISO Central Secretariat accepts no liability in this area.

Adobe is a trademark of Adobe Systems Incorporated.

Details of the software products used to create this PDF file can be found in the General Info relative to the file; the PDF-creation parameters were optimized for printing. Every care has been taken to ensure that the file is suitable for use by ISO member bodies. In the unlikely event that a problem relating to it is found, please inform the Central Secretariat at the address given below.

© ISO 2006

All rights reserved. Unless otherwise specified, no part of this publication may be reproduced or utilized in any form or by any means, electronic or mechanical, including photocopying and microfilm, without permission in writing from either ISO at the address below or ISO's member body in the country of the requester.

ISO copyright office
Case postale 56 • CH-1211 Geneva 20
Tel. + 41 22 749 01 11
Fax + 41 22 749 09 47
E-mail copyright@iso.org
Web www.iso.org

Published in Switzerland

Contents

Page

Foreword.....	iv
Introduction	v
1 Scope	1
2 Normative references	1
3 Terms and definitions.....	1
4 Symbols and abbreviated terms	5
5 General test conditions	6
5.1 Ambient conditions	6
5.2 Test site	6
5.3 Vehicle preparation.....	6
6 Downhill test.....	7
6.1 General.....	7
6.2 Downhill test track.....	8
6.3 Normal test parameters.....	8
6.4 Determination of specific test parameters	9
6.5 Conducting the downhill test	12
6.6 Presentation of results	14
7 Drag test (gradient simulation test)	14
7.1 General.....	14
7.2 Drag test track.....	14
7.3 Regular test parameters.....	14
7.4 Determination of specific test parameters	15
7.5 Conducting the drag test	15
7.6 Data processing and presentation of results	16
8 Indoor vehicle test on a test bench (gradient simulation test)	17
8.1 General.....	17
8.2 Description of the test bench	17
8.3 Normal test parameters.....	18
8.4 Determination of specific test parameters	19
8.5 Conducting the dynamometer test	19
8.6 Data processing and presentation of results	20
Annex A (normative) Vehicle data	22
Annex B (normative) Test reports	23
Bibliography	26

Foreword

ISO (the International Organization for Standardization) is a worldwide federation of national standards bodies (ISO member bodies). The work of preparing International Standards is normally carried out through ISO technical committees. Each member body interested in a subject for which a technical committee has been established has the right to be represented on that committee. International organizations, governmental and non-governmental, in liaison with ISO, also take part in the work. ISO collaborates closely with the International Electrotechnical Commission (IEC) on all matters of electrotechnical standardization.

International Standards are drafted in accordance with the rules given in the ISO/IEC Directives, Part 2.

The main task of technical committees is to prepare International Standards. Draft International Standards adopted by the technical committees are circulated to the member bodies for voting. Publication as an International Standard requires approval by at least 75 % of the member bodies casting a vote.

Attention is drawn to the possibility that some of the elements of this document may be the subject of patent rights. ISO shall not be held responsible for identifying any or all such patent rights.

ISO 12161 was prepared by Technical Committee ISO/TC 22, *Road vehicles*, Subcommittee SC 2, *Braking systems and equipment*.

Introduction

This International Standard applies to complete vehicles and not to endurance braking systems on their own.

Depending on the available test facilities the vehicles equipped with endurance braking systems shall be tested for type approval using one of the following types of tests:

Outdoor tests

- Downhill vehicle test (see Clause 6)
- Vehicle drag test (see Clause 7)

Indoor test (see Clause 8)

- Dynamometer vehicle test

All three tests are evaluated from downhill braking manoeuvres and are to different degrees gradient simulation tests.

Road vehicles — Endurance braking systems of motor vehicles and towed vehicles — Test procedures

IMPORTANT — When using this International Standard, care should be taken to ensure that changes have not subsequently been adopted that affect the test methods or values given.

1 Scope

This International Standard specifies methods for testing the endurance braking systems of vehicles of categories M N and O (excluding M1, N1, O1 and O2) which are designed to comply with ECE-R 13/09 with supplement 1 to 6. The values given in square brackets are taken from ECE Regulation No. 13 for information.

All endurance test procedures are based on the principle of equivalent energy absorption and procedures which are not suitable to support this principle are not considered.

The principle of equivalent energy allows the base test parameters to be adapted to the variations occurring under real conditions compared to theoretical values.

NOTE Typical sources are:

- The variation of the gradient of downhill test track or
- The variation of retarding force during drag tests or indoor test.

2 Normative references

The following referenced documents are indispensable for the application of this document. For dated references, only the edition cited applies. For undated references, the latest edition of the referenced document (including any amendments) applies.

ISO 611: 2003, *Road vehicles — Braking of automotive vehicles and their trailers — Vocabulary*

ISO 1176: 1990, *Road vehicles — Masses — Vocabulary and codes*

ISO 3833: 1977, *Road vehicles — Types — Terms and definitions*

ISO 8855, *Road vehicles — Vehicle dynamics and road-holding ability — Vocabulary*

ECE Regulation No. 13, *Uniform provisions concerning the approval of vehicles with regard to braking*, incorporating the series 09 with supplements 1 to 6

3 Terms and definitions

For the purposes of this document, the terms and definitions given in ISO 611, ISO 1176 and ISO 3833 and the following apply.

3.1

vehicle categories

as defined in ECE R.E.3, the Consolidated Resolution on the construction of vehicles:

- category M: power-driven vehicles having at least four wheels and used for the carriage of passengers;
- category N: power-driven vehicles having at least four wheels and used for the carriage of goods

3.2

endurance braking system

total of all devices of a vehicle which enable the driver to reduce the speed or to transverse a long descent at nearly a constant speed without the use of the service brake

NOTE 1 An endurance braking system may contain one or more retarder(s), and may include:

- energy supplying means;
- control device(s);
- transmission means;
- retarder(s);
- energy dissipation device(s);
- auxiliary device(s).

NOTE 2 All retarders are new and fully burnished according to the supplier recommendations.

3.2.1

types of control device used in endurance braking system

3.2.1.1

independent control device

device which controls the endurance braking system independently from the service braking system

3.2.1.2

integrated control device

device applied simultaneously with the service braking systems or with a suitably phased operation

3.2.1.3

vehicle speed control device

device which allows a nearly constant vehicle speed by automatic operation and modulation of the endurance braking system

3.2.1.4

cut-out device

device which allows to apply the service braking system alone or to use the vehicle speed control without actuating the endurance braking system

NOTE This is a combined control device.

3.2.2

retarder

energy transformation device used to provide braking effort allowing control of vehicle speed independently of or as a supplement to the friction brakes

3.2.2.1 categories of retarders

3.2.2.1.1

primary retarder

retarder located on the drive train of a motor vehicle at the engine side of the gearbox (torque converter)

3.2.2.1.2

secondary retarder

retarder located on the drive train of motor vehicles between the gearbox (torque converter) and the drive axle(s)

NOTE Retarders can be connected to non-driven axles and are also classed as secondary retarders.

3.2.2.1.3

other retarders

retarders which are not categorized in 3.2.2.1.1 or 3.2.2.1.2 (e.g. aerodynamic retarders)

3.2.2.2

types of retarders

3.2.2.2.1

combustion engine retarder

3.2.2.2.1.1

engine braking

means whereby the engine drag resulting from the reduction of the fuel input and the throttling of the induction air supply whilst the engine is linked to the driving wheels retards the vehicle (see 5.5.3.1.3.1 of ISO 611:2003)

3.2.2.2.1.2

engine retarder

mechanism in which an increased retarding effect is obtained by changing the valve timing to increase the internal resistance (drag) of the engine (see 5.5.3.1.3.2 of ISO 611:2003)

3.2.2.2.1.3

exhaust retarder

mechanism in which an increased retarding effect is obtained by blocking the flow of the exhaust gas to increase the internal resistance of the engine (see 5.5.3.1.3.3 of ISO 611:2003)

3.2.2.2.2

electric traction motor retarder

mechanism in which the electric traction motor, linked to the driving wheels, exercises a retarding effect on the moving vehicle, for example, by functioning as a current generator (see 5.5.3.1.3.4 of ISO 611:2003)

3.2.2.2.3

hydraulic retarder

retarder in which a retarding effect is obtained by the action of liquid on rotating/pumping components linked to one or more wheels

3.2.2.2.3.1

hydrodynamic retarder

hydraulic retarder in which the power absorption is based on the principle of specific kinetic energy of a fluid

3.2.2.2.3.2

hydrostatic retarder

hydraulic retarder in which the power absorption is based on the principle of specific kinetic energy of a fluid

3.2.2.2.4
electric retarders

3.2.2.2.4.1
electromagnetic retarder

retarder in which a retarding effect is obtained by the action of an electromagnetic field on a rotating component (eddy current, hysteresis) linked to one or more wheels

3.2.2.2.4.2
permanent-magnetic retarder

mechanism in which a retarding effect is obtained by the action of a permanent-magnetic field on a rotating component (eddy current, hysteresis) linked to one or more wheels

3.2.2.2.5
regenerative braking retarder

any type of retarder which recovers the vehicle's kinetic energy through the braking torque in order to restore it to a vehicle energy reservoir

3.2.2.2.6
aerodynamic retarder

mechanism in which a retarding effect is obtained by causing an increase in the air resistance, for example, by the deployment of movable surfaces

[ISO 611:2003]

3.3
vehicle loading

3.3.1
laden vehicle

vehicle laden to its maximum technically permissible mass as specified by the vehicle manufacturer and acknowledged by the technical services

3.4
energy

3.4.1
dissipated energy

amount of energy dissipated through braking during any braking operation of a vehicle or vehicle combination taking into account a rolling resistance of 1 % of g

$$W_{\text{diss}} = W_{\text{pot}} - W_{\text{rr}}$$

$$W_{\text{pot}} = m \times g \times \Delta H$$

$$W_{\text{rr}} = m \times g \times \left(\frac{\Delta H}{\tan \alpha} \times 0,01 \right)$$

3.4.2
equivalent energy $W_{\text{equ,II}}$

energy of a vehicle dissipated while braking downhill when this dissipated energy is equivalent to that dissipated in the same period of time with the vehicle driven at an average speed of 30 km/h on a [6 %] down-gradient for a distance of [6 km]

$$W_{\text{equ,II}} = W_{\text{diss,II}} = f(\tan \alpha = 6 \%, l = 6 \text{ km})$$

4 Symbols and abbreviated terms

For the purposes of this International Standard, the symbols given in Table 1 apply.

Table 1 — Symbols

α	angle of the down gradient (from the horizontal)	rad
a_m	mean deceleration	m/s^2
d_m	mean fully developed deceleration	m/s^2
E	wheelbase	m
F	towing force	N
F_{rr}	rolling resistance	N
l	length of the test "track" or equivalent	m, km
l', l''	modified length of the test "track" or equivalent	m, km
m	mass of the vehicle or vehicle combination	kg
M	torque, braking torque, driving torque of dynamometer	Nm
m', m''	modified mass	kg
N	number of measurement samples	-
P	power	W
P_{ret}	retarding power resp. braking power	W
P_{rr}	dissipated power due to the rolling resistance while braking	Nm/s or W
r	radius	m
t	time	s
T	duration of the test	s
T_{req}	required duration of the test	s
$\tan \alpha$	gradient of the down slope	%
$\tan \alpha_m$	average gradient of the downhill test road	%
$\tan \alpha_m'$	modified average gradient of the downhill test road	%
v	vehicle speed	m/s
v_{aver}	average speed	m/s
v_{req}	required test speed	m/s
v', v''	modified vehicle speed	m/s
W_{diss}	dissipated energy while braking	Nm or W
W_{pot}	potential energy while downhill braking	Nm or W
W_{rr}	dissipated energy due to the rolling resistance while braking	Nm or W
ΔH	difference of altitude	m
$\Delta H', \Delta H''$	modified difference of altitude	m

5 General test conditions

5.1 Ambient conditions

5.1.1 Wind speed

The tests shall be performed when there is no wind liable to affect the results.

5.1.2 Air temperature

The air temperature shall be noted in the test report.

5.1.3 Road surface condition

Any test road shall be smooth, hard-surfaced and free of loose material, and thereby provide a sufficient peak coefficient of adhesion to prevent excessive wheel slip.

5.2 Test site

Any test site should be of adequate size and length and without obstacles, and be able to provide a safe testing environment.

The length of the test track shall be established by suitable means of distance measurements with a tolerance of $\pm 1,0$ %.

5.3 Vehicle preparation

5.3.1 Instrumentation

The test vehicle (and the towing vehicle if appropriate) shall be prepared for testing by the installation of additional instruments and/or calibration of the existing standard vehicle instruments, as required.

All the instruments shall be checked to ensure correct function and, with the vehicle stationary on the test surface, all the instruments shall be set.

The instrumentation shall be able to measure the following parameters.

5.3.1.1 Vehicle speed

If the recording of the vehicle speed is required, a separate speed measuring device independent of any wheel slip shall be used.

5.3.1.2 Duration of the test

The duration of the test shall be measured by means of a chronometer or electronic timing equipment.

5.3.1.3 Engine speed

For monitoring the permissible engine speed, the instrument on the dashboard is sufficient.

5.3.1.4 Temperatures

For surveying the permissible temperature of the engine cooling system the instrument on the dashboard is sufficient.

Separate temperature measuring means shall be used when stabilized operating conditions are required.

5.3.1.5 Towing force

The towing force during the drag test shall be measured by means of a strain-gauged and calibrated towing link/coupling, and the measuring system shall provide a visible reading and a signal for producing a permanent force record.

5.3.2 Verification and calibration of the measuring instruments

Prior to the test check that:

- the vehicle instruments such as the tachograph, the engine revolution-counter and the coolant thermometer work properly;
- a separate distance and speed measuring system and the chronometer work properly;
- other sensors such as the towing link sensor system are calibrated and registered.

5.3.3 Vehicle to be tested

5.3.3.1 Vehicle

Technical data of the test vehicle or vehicle combination shall be recorded according to Annex A.

At the beginning of the test, the normal operating temperature of the engine according to the operator's manual shall be reached.

5.3.3.2 Endurance braking system

For evaluation of the test results, the technical specification of the endurance braking system shall be recorded according to Annex A.

The endurance braking system shall be in proper working condition and ready for operation. This includes making sure that the normal operating temperatures according to the manufacturer's specifications are reached.

The instructions of the endurance braking system manufacturer (see operating instructions of endurance braking system) shall be taken into account.

5.3.3.3 Towing vehicle

The towing vehicle shall be able to pull the test vehicle or vehicle combination during the whole test with a nearly constant speed as required. Gear changing shall be limited to a necessary minimum. It shall be possible to communicate with the driver of the test vehicle by either visual or audible means.

6 Downhill test

6.1 General

The basic requirement of the downhill test is that the dissipated energy shall be equal to the equivalent energy according to ECE-R 13 Annex 4.

6.2 Downhill test track

6.2.1 General

The downhill test may be made on any quiet road where the average gradient and length satisfy the required values (e.g. 6 % and 6 km according to UN-ECE Regulation 13 or variations thereof according to 6.4). However, the local gradient is not required to be strictly constant but may vary along the test road.

6.2.2 Altitude difference

The difference in altitude between two points along the test track shall be determined by suitable means of altitude measurements with a tolerance of $\pm 0,5$ %.

6.2.3 Gradient of test road

The average gradient of the downhill test road is the difference of the altitudes between the beginning and the end of the test track divided by the distance between those points.

$$\tan \alpha_m = \frac{H}{l}$$

6.2.4 Permissible tolerance of local gradient along the test track

The local gradient $\tan \alpha_{loc}$ along the test road may vary ± 50 % of $\tan \alpha_m$.

6.2.5 Specific local characteristics of a realistic downhill test road

A downhill road including a maximum of five curves or temporary obstacles, requiring a short and significant speed reduction but not below 10 km/h, is allowed as a test site. These conditions permit correction as stated in 6.4 to be valid.

6.3 Normal test parameters

The following regular test parameters are:

- length of the test road;
- gradient of the test road;
- test speed; and
- loading condition — laden.

The parameters given in Table 2 shall be taken from the values given by Regulation 13 and shall be used as a basis for the test.

Table 2 — Regular test parameters given by Regulation 13

ECE-R 13 Annex 4	Speed km/h	Gradient (tan α) %	Distance km	Rolling resistance %
Type II	30	6	6	1
Type IIA	30	7	6	1

The normal duration of the test is 12 min, calculated from speed and distance.

The difference of altitude of the downhill test road may be calculated using the values of Table 2 and the following formula:

$$\Delta H = l \tan \alpha$$

The mass of the vehicle or the vehicle combination to be tested shall be specified by the applicant according to the required loading condition.

6.4 Determination of specific test parameters

6.4.1 General

The test parameters, such as speed, gradient, mass, etc., shall be determined according to the real conditions of the available test track in order to conduct the tests alternatively on downhill test sites with gradients which differ from those of Table 2. Based on the principle of equivalent energy, the specific parameters or combinations of parameters may be altered as set out in the following clauses. The calculations and results thereof shall be documented.

6.4.2 Required adjustment of altitude and duration of the type IIA test to compensate for a short application of the service braking system

For a test road with a number of narrow curves or temporary obstacles which require an additional but brief short use of the service braking system as specified in 6.2.5, the test parameters shall be compensated as follows:

- For each significant speed reduction by using the service braking system the length of the test track shall be extended in advance such that the difference in altitude shall be increased by 7 m. The required duration of the test and the distances travelled shall be extended according to 6.5.2.2.2 or 6.5.2.2.3.
- As an alternative to the extension of the length of the test road, the mass of the vehicle or vehicle combination may be increased in order to add the corresponding amount of energy (see 6.4.3).

6.4.3 Adjustment of mass to compensate for a difference of altitude

If the available test road provides the prescribed length but not the prescribed gradient and thus a difference of altitude $\Delta H'$ different from the necessary altitude difference (see Figure 1), the mass of the test vehicle or vehicle combination shall be modified to m' using the following formula, which is based on the principle of the equivalent energy:

$$m' = m \times \frac{\Delta H - 0,01 \times l}{\Delta H' - 0,01 \times l}$$

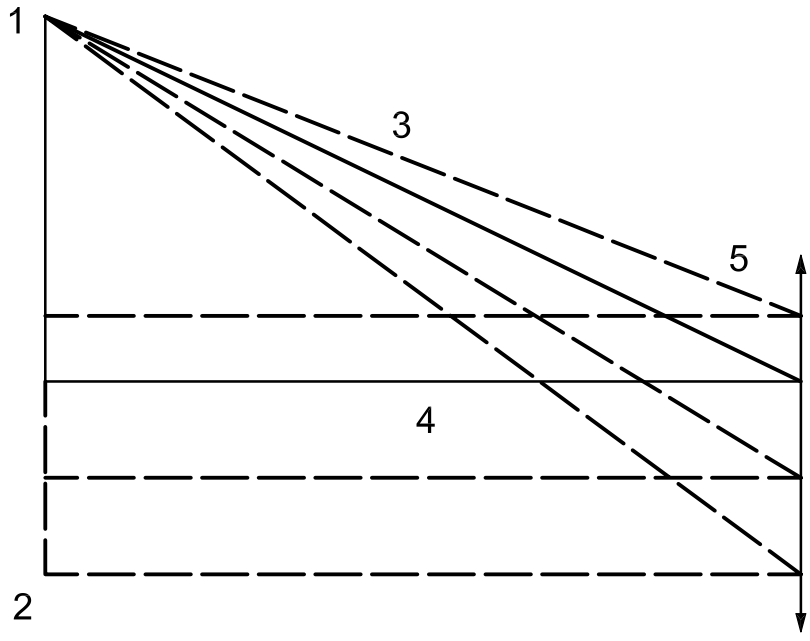

- Key**
- 1 top
 - 2 bottom
 - 3 $W_{diss} = \text{const.}$
 - 4 $l = \text{const.}$
 - 5 ΔH variable

Figure 1 — Variable altitude

6.4.4 Adjustment of test speed to compensate for a deviation of gradient

If the available test road provides the prescribed altitude difference but not the prescribed gradient and thus the road length (see Figure 2), the average test speed v' shall be calculated from the average gradient of the actual downhill test road $\tan \alpha'$ (based on the principle of the equivalent energy and the nominal mass of the vehicle or combination), and is such that the duration of the test shall not be altered:

$$v' = v \times \frac{\tan \alpha - 0,01}{\tan \alpha' - 0,01}$$

Due to the fact that the same period of time is required, the necessary length of the downhill test track shall be:

$$l' = l \times \frac{v'}{v}$$

The resulting difference of altitude is:

$$\Delta H' = l' \tan \alpha'$$

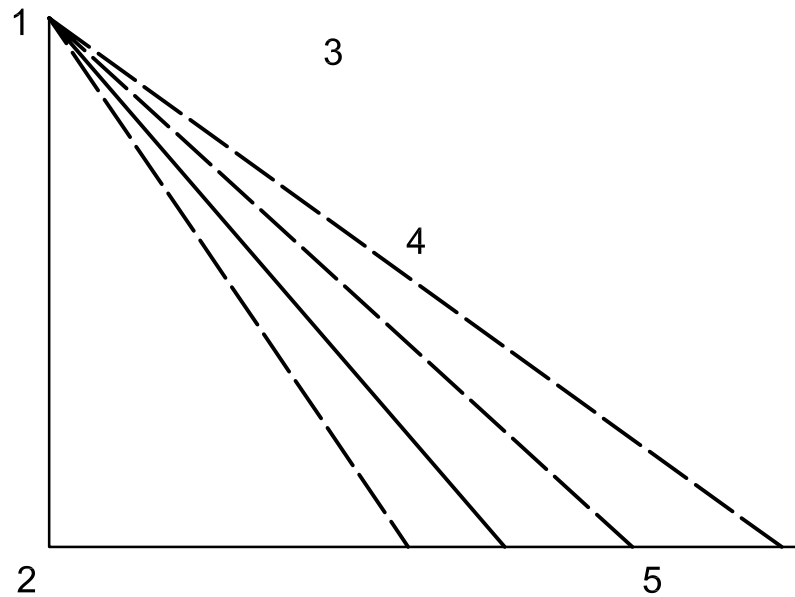

Key

- 1 top
- 2 bottom
- 3 $m = \text{const.}, p = \text{const.}$
- 4 variable $\tan \alpha$
- 5 variable l

Figure 2 — Variable gradient

Table 3 — Examples for type II

Variable	Unit	Normal value	Example 1	Example 2	Example 3	Example 4
$\tan \alpha$	%	6,0	5,5	5,2	6,5	7,2
v	km/h	30,0	33,3	35,7	27,3	24,2
l	km	6,0	6,7	7,1	5,5	4,8
ΔH	m	360,0	366,7	371,4	354,5	348,4

Table 4 — Examples for type IIA

Variable	Unit	Normal value	Example 1	Example 2	Example 3	Example 4
$\tan \alpha$	%	7,0	6,5	6,0	7,5	8,5
v	km/h	30,0	32,7	36,0	27,7	24,0
l	km	6,0	6,5	7,2	5,5	4,8
ΔH	m	420,0	425,5	432,0	415,4	408,0

The calculated average test speed v_{calc} shall match the normal parameter test speed [30 km/h] within a tolerance of $\pm 20\%$.

If the calculated average test speed v_{calc} exceeds this tolerance range, this road is not suitable for downhill testing of vehicles with nominal mass. However, modification of the mass of the vehicle or combination of vehicles may be determined according to 6.4.5.

6.4.5 Adjustment of vehicle mass and speed to compensate for a deviation of road gradient and length

If the available test road provides the required altitude difference but not the required gradient and thus road length such that the calculated average test speed according to 6.4.4 exceeds the tolerance of $\pm 20\%$, the mass of the vehicle or combination of vehicles may be modified so as to correct the dissipated energy.

The mass shall be calculated from the average gradient so that the resulting speed is within the tolerance range.

$$v' = v \times \frac{\tan \alpha - 0,01}{\tan \alpha' - 0,01}$$

v' is the calculated speed v_{calc} , which is out of tolerance v'' shall now be chosen within the tolerance $30 \text{ km/h} \pm 20\%$.

$$m'' = m' \times \frac{v'}{v''} \quad (m' = m)$$

The nominal duration of the test shall not be altered. Therefore, the length of the test track is required as following:

$$l'' = l' \times \frac{v''}{v'}$$

The resulting difference of altitude is:

$$\Delta H'' = l'' \times \tan \alpha'$$

When the calculated difference of altitude can not be provided, this road is not suitable for downhill testing.

6.4.6 Specific vehicle conditions

When the applicant prefers to test the maximum performance of the endurance braking system, a weight higher than the gross vehicle weight (GVW) or gross combination weight (GCW) is allowed, but shall comply to the other appropriate legal requirements.

6.5 Conducting the downhill test

6.5.1 Recording of test data

For verification of the test procedure, the driven distance and the test duration, as well as the lowest and highest driven speeds, shall be recorded.

6.5.2 Test procedure

The endurance braking system shall be conditioned as prescribed in 5.3.3.2.

The gear engaged shall be such that the speed of the engine does not exceed the maximum value prescribed by the manufacturer.

6.5.2.1 Required test speed

The required average speed v_{req} is the calculated average speed, determined according to 6.4.4. A tolerance of ± 5 km/h for the actually driven speed is allowed.

The test vehicle shall enter and leave the test section of the downhill test site within a tolerance of ± 5 km/h on the required average speed.

6.5.2.1.1 Exception for vehicles fitted with primary retarders

For vehicles in which the energy is absorbed by the braking action of primary retarders alone, a tolerance of ± 5 km/h on the calculated average test speed as per 6.5.2.1 shall be permitted for the required average speed v_{req} , and the gear enabling the speed v_{req} to be stabilized at a value closest to the calculated average test speed shall be engaged.

6.5.2.2 Duration of the test

6.5.2.2.1 General

The time between the beginning and the end of the test section shall be measured. The duration of the downhill test shall normally be $T_{\text{req}} = [12]$ min.

6.5.2.2.2 Duration of the test for vehicles fitted with primary retarders

The time between the beginning and the end of the test section shall be measured. The duration T_{req} of the downhill test shall be calculated using the following formula:

$$T_{\text{req}} = \frac{l}{v_{\text{req}}}$$

6.5.2.2.3 Extension of the duration of the test if a short use of the service braking system is necessary

If the altitude difference must be adjusted for compensation of a brief application of the service brakes according to 6.4.2, the maximum duration of the downhill test shall be extended by 12 s for each use of the service brakes.

6.5.2.2.4 Permissible reduction of duration of test

Where the performance of the endurance braking system is clearly not affected by the distance travelled or any other conditions during the test run, the test may be terminated before the nominal duration of the test has been reached.

The premature termination of the downhill test is allowed under the following conditions:

- a) Steady state conditions of operating parameters such as
 - vehicle speed and
 - coolant temperature
 have been reached and maintained for at least one minute.
- b) The section of the test track which is covered during this one minute provides a nearly constant downhill gradient.

- c) The actual constant vehicle speed is the value corresponding to the actual gradient being used according to Table 2 or using the formula given in 6.4.5.

In this case the necessary data shall be recorded.

6.6 Presentation of results

The principle of the equivalent energy is fulfilled and the test is successfully completed if the measured duration of the test has not exceeded the duration defined in 6.5.2.2.1 to 6.5.2.2.3, allowing a tolerance of + 15 s or if the conditions of 6.5.2.2.4 are completely fulfilled.

The test results shall be documented in the form given in B.1.

7 Drag test (gradient simulation test)

7.1 General

The drag test is an accepted means of simulating downhill braking on a level road in which the simulated force due to the gradient is generated by a towing vehicle.

The requirement of the drag test is that the dissipated energy shall be equal to the equivalent energy according to Regulation ECE-R13.

7.2 Drag test track

The drag test may be made on every level road where the required distance and speed can be driven without interruption.

7.3 Regular test parameters

7.3.1 General

The parameters

- test speed and
- distance

of Table 5 are the values given by Regulation 13 and shall be used.

Table 5 — Regular test parameters, values given by Regulation 13

ECE-R 13 Annex 4	Speed km/h	Gradient %	Distance km	Rolling resistance %
Type II	30	6	6	1
Type IIA	30	7	6	1

The normal duration of the test is 12 min, calculated from speed and distance.

The mass of the vehicle or the vehicle combination to be tested shall be specified such as the endurance braking forces can be transmitted to the road surface without excessive wheel slip.

7.3.2 Determination of the required dissipated energy

Taking into account the rolling resistance of 1 %, the required dissipated energy shall be:

$$W_{\text{dissII}} = mg \cdot 6\,000 \times (0,06 - 0,01)$$

$$W_{\text{dissIIa}} = mg \cdot 6\,000 \times (0,07 - 0,01)$$

The vehicle weight in this formula is equal to the GVW or GCW for which type approval is being sought.

7.4 Determination of specific test parameters

7.4.1 Test speed

The required average test speed v_{req} shall be equal to the speed given in Table 5. The actual speed should be nearly constant but at least within a tolerance of ± 5 km/h. The towing force (resp. braking force of the towed vehicle) may vary during the test.

7.4.1.1 Exception for vehicles fitted with primary retarders

For vehicles in which the energy is absorbed by the braking action of primary retarders alone, a tolerance of ± 5 km/h on the speed given in Table 5 shall be permitted, and the gear enabling the speed v_{req} to be stabilized at a value closest to the speed given in Table 5 shall be engaged.

Under certain circumstances due to the available transmission ratio even higher speeds may be agreed by the approval authority with strict respect to the principle of equivalent energy.

7.5 Conducting the drag test

7.5.1 Recording of data

For verification of the test procedure for later data processing, the towing force and the vehicle speed shall be recorded as functions of the time, and the driven distance and the test duration shall be reported.

7.5.2 Test procedure

7.5.2.1 General

The endurance braking system shall be conditioned as prescribed in 5.3.3.2.

The engine of the towed vehicle shall be started and the gear engaged shall be such that the speed of the engine does not exceed the maximum value prescribed by the manufacturer.

7.5.2.2 Duration of the test

7.5.2.2.1 Normal duration

The duration of the drag test shall normally be 12 min.

7.5.2.2.2 Duration of the test for vehicles fitted with primary retarders

The duration T_{req} of the drag test shall be calculated from

$$T_{\text{req}} = \frac{l}{v_{\text{req}}}$$

7.5.2.2.3 Permissible reduction of duration of test

Where the performance of the endurance braking system is clearly not affected by the distance travelled or any other conditions during the test run, the test may be terminated before the nominal duration of the test has been reached.

The premature termination of the drag test is allowed if steady state conditions of coolant temperature, towing force and vehicle speed have been reached and maintained for at least one minute. For this purpose, the corresponding data shall be recorded.

7.6 Data processing and presentation of results

7.6.1 Evaluation of test data

7.6.1.1 Data processing of vehicle speed

Depending on the kind of data acquisition the average vehicle speed is:

$$v = \frac{l}{T}$$

or

$$v = \frac{\sum_{i=1}^N v_i}{N}$$

or

$$v = \frac{1}{T} \int_{t_0}^T v(t) dt$$

7.6.1.2 Data processing of towing force

The average towing force is:

$$F = \frac{\sum_{i=1}^N F_i}{N}$$

or

$$F = \frac{1}{T} \int_{t_0}^T F(t) dt$$

7.6.1.3 Rolling resistance

The force to overcome the rolling resistance of the towed vehicle is considered to be 1 % of the actual towed vehicle mass.

7.6.1.4 Data processing of dissipated energy

The dissipated energy is:

$$W_{\text{diss}} = \left(\sum_{i=1}^N F_i \times v_i \times \Delta t \right) - (F_{\text{rr}} \times v_{\text{aver}} \times T)$$

or

$$W_{\text{diss}} = \int_{t_0}^T F(t) \times v(t) dt - (F_{\text{rr}} \times v_{\text{aver}} \times T)$$

The average retarding power may be determined as:

$$P_{\text{ret}} = \frac{W_{\text{diss}}}{T}$$

7.6.2 Evaluation of test data

7.6.2.1 Comparison of dissipated and required energy

The principle of the equivalent energy is fulfilled and the test has been successfully performed if the dissipated energy according to 7.6.1.4 is greater than or equal to the required energy according to 7.3.1.

Where the duration of the test has been cut short according to 7.5.2.2.2, the required energy shall be reduced in proportion to the effective duration of the test in relation to the normal required duration.

7.6.2.2 Presentation of results

The test results shall be documented in the form given in B.2.

8 Indoor vehicle test on a test bench (gradient simulation test)

8.1 General

The indoor test may be made on a rolling road dynamometer if it is able to simulate downhill braking conditions by the powered driving motor of the test bench. Practically seen, the dynamometer test at constant speed mode is the indoor simulation of the drag test.

The dissipated energy shall be equal to the equivalent energy according to ECE-R 13.

8.2 Description of the test bench

The dynamometer test bench shall provide a rolling road. The vehicle to be tested shall be secured in such a position that the driven axle(s) has (have) a rolling contact on to a power driven drum of the test bench.

The diameter of the drum shall be at least twice the diameter of the tyres.

The test bench design shall allow measurements of the input torque and speed to permit calculation of the power required to drive the drums against the action of the endurance braking system.

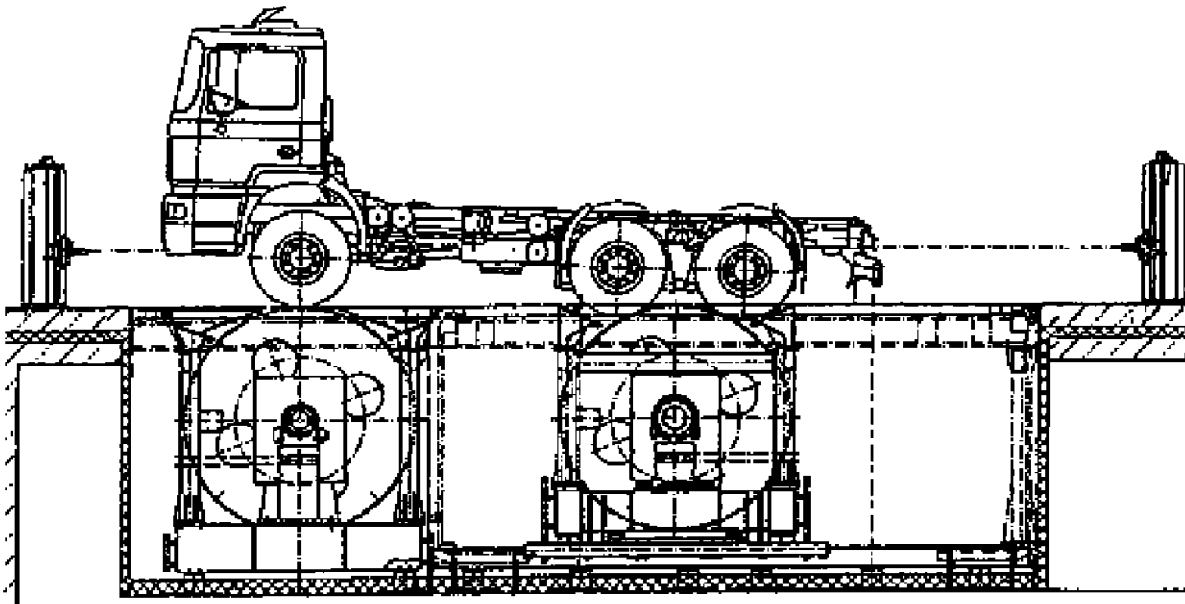

Figure 3 — Truck dynamometer test bench

The test bench shall provide a realistic cooling effect by the provision of a suitable airstream.

8.3 Normal test parameters

8.3.1 General

The normal test parameters are:

- test speed; and
- distance.

The parameters in Table 6 have been taken from the values given by Regulation 13 and the initial drum speed. The constant dynamometer torque input to the wheels shall be set to provide these parameters.

Table 6 — Normal test parameters, values given by Regulation 13

ECE-R 13 Annex 4	Speed km/h	Gradient (tan ∇) %	Distance, l km	Rolling resistance %
Type II	30	6	6	1
Type IIA	30	7	6	1

The normal duration of the test is [12] min, calculated from speed and distance.

The drive axle loading of the vehicle on the test bench shall be specified such that the endurance braking forces can be transmitted to the surface of the drums of the test bench without excessive wheel slip.

8.3.2 Determination of the required dissipated energy

Taking into account the rolling resistance of 1 %, the required dissipated energy shall be:

$$W_{\text{dissII}} = mg \times 6\,000 \times (0,06 - 0,01)$$

$$W_{\text{dissIIa}} = mg \times 6\,000 \times (0,07 - 0,01)$$

The vehicle mass in this formula is equal to the maximum permissible mass of the vehicle or the combination for which the type approval shall be given.

8.4 Determination of specific test parameters

8.4.1 Test speed

The required average test speed v_{req} shall be equal to the speed given in Table 6. The actual speed should be nearly constant but at least within a tolerance of ± 5 km/h.

8.4.1.1 Exception for vehicles fitted with primary retarders

For vehicles in which the energy is absorbed by the braking action of primary retarders alone, a tolerance of ± 5 km/h on the required average test speed v_{req} given in Table 6 shall be permitted. This is in order to suit the gear ratios of the vehicle to achieve maximum braking torque at safe engine speed prescribed by the manufacturer. The gear enabling the speed v_{req} to be stabilized at a value closest to the speed given in Table 6 shall be engaged.

Under certain circumstances, due to the available drivelling ratio, even higher speeds may be agreed by the approval authority with strict respect to the principle of equivalent energy.

8.5 Conducting the dynamometer test

8.5.1 Recording of data

For data post-processing, the input torque from driven motor and the rotational speed of the drum(s) shall be recorded as functions of the time. The “driven” distance and the test duration shall be reported.

8.5.2 Preparation of the test

The endurance braking system shall be conditioned as prescribed in 5.3.3.2.

The engine of the tested vehicle shall be started and the gear engaged shall be such that the speed of the engine does not exceed the maximum value prescribed by the manufacturer.

8.5.3 Test procedure

8.5.3.1 General

The test is made with the dynamometer operating in the “controlled speed” mode and should therefore be held at a near constant speed v_{req} .

The retarder shall be set at the maximum output position and the dynamometer torque shall be recorded and integrated so that the total absorbed energy can be calculated in real time.

Note that this torque may vary, depending on the retarder characteristics, as the test proceeds and note also that the driving torque figure includes that component needed to overcome engine braking.

8.5.3.2 Duration of the test

The duration of the test shall normally be 12 min.

The test shall continue until the total energy absorbed is equivalent to that required to hold the laden vehicle or vehicle combination at 30 km/h on the prescribed gradient (depending on the Type II/IIa test being conducted) for 6 km.

This test is successful if that total energy is absorbed in 12 min or less.

8.5.3.3 Duration of the test for vehicles fitted with primary retarders

The duration T_{req} of the drag test shall be calculated with the formula:

$$T_{\text{req}} = \frac{l}{v_{\text{req}}}$$

8.5.3.4 Permissible reduction of duration of test

Where the performance of the endurance braking system is clearly not affected by the distance travelled or any other conditions during the test run, the test may be terminated before the required duration of the test has been reached.

The premature termination of the drag test is allowed if steady state conditions of the following are reached and maintained for at least one minute:

- coolant temperature;
- input torque; and
- vehicle speed.

For evidence purposes, the corresponding data shall be recorded.

8.6 Data processing and presentation of results

8.6.1 Data processing of vehicle speed

The average vehicle speed is

$$v = \frac{l}{T}$$

or

$$v = \frac{\sum_{i=1}^N v_i}{N}$$

or

$$v = \frac{1}{T} \int_{t_0}^T v(t) dt$$

8.6.2 Data processing of input torque

The average input torque is

$$M = \frac{\sum_{i=1}^N (M_{\text{left},i} + M_{\text{right},i})}{N}$$

or

$$M = \frac{1}{T} \int_{t_0}^T (M_{\text{left},i} + M_{\text{right},i}) dt$$

8.6.3 Rolling resistance

The rolling resistance of the tested vehicle shall be determined in a separate test run at the required speed with braking systems not applied.

$$P_{\text{rr}} = \frac{\sum_{i=1}^N F_{\text{rr}} \times v_i \times \Delta t}{T}$$

8.6.4 Data processing of dissipated energy

The dissipated energy is

$$W_{\text{diss}} = \left(\sum_{i=1}^N M_i \times \frac{v_i}{r} \times \Delta t \right) - N \Delta t \times P_{\text{rr}}$$

or

$$W_{\text{diss}} = \int_{t_0}^T \frac{M(t) \times v(t)}{r} dt - T \times P_{\text{rr}}$$

The retarding power may be determined as

$$P_{\text{ret}} = \frac{W_{\text{diss}}}{T}$$

8.6.5 Comparison of dissipated and required energy

The principle of the equivalent energy is fulfilled and the test is successfully completed if the dissipated energy according to 8.6.4 is greater than or equal to the required energy according to 8.3.1.

If the duration of the test has been cut short according to 8.5.3.4, the required energy shall be reduced in proportion to the effective duration of the test in relation to the required duration.

8.6.6 Presentation of results

The test results shall be documented in the form given in B.3.

Annex A
(normative)

Vehicle data

Vehicle category M, N, O

Trade name or mark of the vehicle

Vehicle type

Vehicle identification No.

Engine type

Engine power

Maximum engine speed
(described by the manufacturer)

Ratios

Number of gears

Ratio of gears used

Ratio(s) of transfer case

Total axle ratio(s)

Tyre dimension on driven axle(s)

Mass of vehicle when tested

Axle No. 1

Axle No. 5

Axle No. 3

Axle No. 4

Axle No. 5

Total

Type(s) of the endurance braking system(s)

Type of operating control

Measuring devices

Speed

Towing force

Temperature

Distance

Technical Service

Place/Date

Address

Name/Function

Sign

Annex B (normative)

Test reports

B.1 Downhill test report

Weather conditions

air temperature _____
road surface condition _____
wind speed _____

Test site

average gradient _____
length _____
difference of altitude _____

Vehicle operation

engaged gear _____
engaged retarder position _____

Reported data from the dashboard

engine speed	max	_____
	min	_____
cooling system temperature	start	_____
	end	_____
maximum speed		_____
minimum speed		_____

Test results													
required average test speed													
duration of the test													
measured average speed													
driven distance													
<p>Measured duration of the test is less than or equal to required duration with completely fulfilled conditions</p> <p style="text-align: right; margin-right: 20px;">yes non</p> <table border="1" style="margin-left: auto; margin-right: auto; border-collapse: collapse;"> <tr> <td style="width: 50px; height: 20px;"></td> <td style="width: 50px; height: 20px;"></td> </tr> </table> <p>or</p> <p>in case of permissible reduction of duration of test:</p> <p style="padding-left: 20px;">The conditions of 6.5.2.2.3 are completely fulfilled</p> <p>1. Steady state conditions of operation parameters such as</p> <table border="0" style="margin-left: 40px;"> <tr> <td style="padding-right: 10px;">— vehicle speed</td> <td style="border: 1px solid black; width: 100px; height: 20px;"></td> <td style="padding-left: 20px; border-bottom: 1px solid black;"></td> </tr> <tr> <td>— coolant temperature</td> <td style="border: 1px solid black; width: 100px; height: 20px;"></td> <td style="padding-left: 20px; border-bottom: 1px solid black;"></td> </tr> </table> <p style="padding-left: 40px;">have reached constant values for at least one minute</p> <p>2. The section of the test track which is passed during this one minute provides a nearly constant downhill gradient</p> <table border="0" style="margin-left: auto; margin-right: auto;"> <tr> <td style="border: 1px solid black; width: 50px; height: 20px;"></td> <td style="border: 1px solid black; width: 50px; height: 20px;"></td> </tr> </table> <p style="text-align: right; margin-right: 20px;">max/min downhill gradient</p> <p>3. The actual constant vehicle speed corresponds to the required test speed.</p> <table border="0" style="margin-left: auto; margin-right: auto;"> <tr> <td style="border: 1px solid black; width: 50px; height: 20px;"></td> <td style="border: 1px solid black; width: 50px; height: 20px;"></td> </tr> </table>			— vehicle speed			— coolant temperature							
— vehicle speed													
— coolant temperature													

Technical Service
Place/Date.....

Address
Name/Function
Sign

B.2 Drag test report

Weather conditions

air temperature _____
road surface condition _____
wind speed _____

Vehicle operation

engaged gear _____
engaged retarder position _____

Reported data from the dashboard

engine speed max _____
min _____
cooling system temperature start _____
end _____
duration of test _____
driven distance _____

Calculation of required dissipated energy

Type II: $W_{\text{requ diss}} = m \cdot g \cdot 6\,000[\text{m}] \cdot 0,05$

Type IIa: $W_{\text{requ diss}} = m \cdot g \cdot 6\,000[\text{m}] \cdot 0,06$

Calculation of dissipated energy

Calculated from the processed data "towing force" and "vehicle speed"

$W_{\text{diss}} = \text{Sum } F_i \cdot v_i \cdot \Delta t - F_{\text{roll}} \cdot v_{\text{aver}} \cdot T$

or

$W_{\text{diss}} = \text{Integral } F \cdot v_{\text{dt}} - F_{\text{roll}} \cdot v_{\text{aver}} \cdot T$

yes no

Permissible reduction of test duration

Test results	
$W_{\text{diss}} \geq W_{\text{requ diss}}$ with completely fulfilled conditions	yes no <input type="text"/> <input type="text"/>

Technical Service..... Address.....
Place/Date..... Name/Function.....
Sign.....

B.3 Indoor test report

Vehicle operation

engaged gear _____

engaged retarder position _____

Test bench

diameter of the drum(s) r_T _____

cooling system _____

air speed _____

area _____

Reported data from the dashboard

engine speed

max _____

min _____

cooling system temperature

start _____

end _____

Duration of the test _____

Driven distance _____

Recorded data

input torque

$$M = \sum M_{il} / N + M_{ir} / N$$

$$M = \text{integral } l, r \, M dt / T$$

average vehicle speed

$$v = l/t \quad \text{or}$$

$$v = \sum v_i / N \quad \text{or}$$

$$v = \text{integral } v dt / T$$

power of rolling resistance

$$P_{\text{roll}} = \sum F_{\text{roll}i} * v_i * \text{delta } t / N$$

Calculation of required dissipated energy

Type II:

$$W_{\text{requ diss}} = m * g * 6000[\text{m}] * 0,05$$

Type IIa:

$$W_{\text{requ diss}} = m * g * 6000[\text{m}] * 0,06$$

Calculation of dissipated energy

$$W_{\text{diss}} = \sum M_i * v_i / r_T * \text{delta } t - P_{\text{roll}} * T$$

$$W_{\text{diss}} = \text{Integral } M * v / r_T dt - P_{\text{roll}} * T$$

yes

no

Permissible reduction of test duration

--	--

Test results	
$W_{\text{diss}} \geq W_{\text{requ diss}}$ with completely fulfilled conditions	yes no <input type="text"/> <input type="text"/>

Technical Service Address

Place/Date Name/Function

Sign

Bibliography

- [1] *Prüfung von Dauerbremsen auf wechselndem Gefälle (Testing of Endurance Brakes on Varying Descents)*, FAT Schriftenreihe Nr. 144, Frankfurt/Main 1998 VDA Verband der Automobilindustrie e.V., (German Association of the Automotive Industry)

