

---

---

**Connections for hydraulic fluid power  
and general use — Hose fittings —**

**Part 3:  
Hose fittings with ISO 6162-1 or  
ISO 6162-2 flange ends**

*Raccordements pour transmissions hydrauliques et applications  
générales — Raccords de flexible —*

*Partie 3: Raccords de flexible avec brides conformes à l'ISO 6162-1 ou  
à l'ISO 6162-2*



Reference number  
ISO 12151-3:2010(E)

© ISO 2010

**PDF disclaimer**

This PDF file may contain embedded typefaces. In accordance with Adobe's licensing policy, this file may be printed or viewed but shall not be edited unless the typefaces which are embedded are licensed to and installed on the computer performing the editing. In downloading this file, parties accept therein the responsibility of not infringing Adobe's licensing policy. The ISO Central Secretariat accepts no liability in this area.

Adobe is a trademark of Adobe Systems Incorporated.

Details of the software products used to create this PDF file can be found in the General Info relative to the file; the PDF-creation parameters were optimized for printing. Every care has been taken to ensure that the file is suitable for use by ISO member bodies. In the unlikely event that a problem relating to it is found, please inform the Central Secretariat at the address given below.



**COPYRIGHT PROTECTED DOCUMENT**

© ISO 2010

All rights reserved. Unless otherwise specified, no part of this publication may be reproduced or utilized in any form or by any means, electronic or mechanical, including photocopying and microfilm, without permission in writing from either ISO at the address below or ISO's member body in the country of the requester.

ISO copyright office  
Case postale 56 • CH-1211 Geneva 20  
Tel. + 41 22 749 01 11  
Fax + 41 22 749 09 47  
E-mail [copyright@iso.org](mailto:copyright@iso.org)  
Web [www.iso.org](http://www.iso.org)

Published in Switzerland

# Contents

Page

Foreword .....	iv
Introduction.....	v
1 Scope.....	1
2 Normative references.....	2
3 Terms and definitions .....	2
4 Performance requirements.....	2
5 Designation of hose fittings .....	2
6 Design.....	3
7 Manufacture .....	3
8 Procurement information .....	4
9 Marking.....	4
10 Identification statement (reference to this part of ISO 12151) .....	4
Bibliography.....	12

## Foreword

ISO (the International Organization for Standardization) is a worldwide federation of national standards bodies (ISO member bodies). The work of preparing International Standards is normally carried out through ISO technical committees. Each member body interested in a subject for which a technical committee has been established has the right to be represented on that committee. International organizations, governmental and non-governmental, in liaison with ISO, also take part in the work. ISO collaborates closely with the International Electrotechnical Commission (IEC) on all matters of electrotechnical standardization.

International Standards are drafted in accordance with the rules given in the ISO/IEC Directives, Part 2.

The main task of technical committees is to prepare International Standards. Draft International Standards adopted by the technical committees are circulated to the member bodies for voting. Publication as an International Standard requires approval by at least 75 % of the member bodies casting a vote.

Attention is drawn to the possibility that some of the elements of this document may be the subject of patent rights. ISO shall not be held responsible for identifying any or all such patent rights.

ISO 12151-3 was prepared by Technical Committee ISO/TC 131, *Fluid power systems*, Subcommittee SC 4, *Connectors and similar products and components*.

This second edition cancels and replaces the first edition (ISO 12151-3:1999), which has been technically revised.

ISO 12151 consists of the following parts, under the general title *Connections for hydraulic fluid power and general use — Hose fittings*:

- *Part 1: Hose fittings with ISO 8434-3 O-ring face seal ends*
- *Part 2: Hose fittings with ISO 8434-1 and 8434-4 24 degree cone connector ends with O-rings*
- *Part 3: Hose fittings with ISO 6162-1 or ISO 6162-2 flange ends*
- *Part 4: Hose fittings with ISO 6149 metric stud ends*
- *Part 5: Hose fittings with ISO 8434-2 37 degree flared ends*
- *Part 6: Hose fittings with ISO 8434-6 60 degree cone ends*

## Introduction

In hydraulic fluid power systems, power is transmitted and controlled through a liquid under pressure within an enclosed circuit. In general applications, the fluid can be conveyed under pressure.

Components are connected through their ports by stud ends on fluid conductor connectors to tubes/pipes or to hose fittings and hoses.



# Connections for hydraulic fluid power and general use — Hose fittings —

## Part 3: Hose fittings with ISO 6162-1 or ISO 6162-2 flange ends

### 1 Scope

This part of ISO 12151 specifies the general and dimensional requirements for the design and performance of flange hose fittings, made of carbon steel, for nominal hose inside diameters of 12,5 mm to 51 mm inclusive, in accordance with ISO 4397, for use with ports and clamps in accordance with ISO 6162-1 and ISO 6162-2.

NOTE 1 Materials other than carbon steel can be supplied as agreed between the manufacturer and user.

NOTE 2 For hose fittings used in hydraulic and pneumatic braking systems on road vehicles (as defined in the scope of ISO/TC 22/SC 2, *Road vehicles*), see ISO 4038, ISO 4039-1 and ISO 4039-2.

These hose fittings (see Figure 1 for a typical example) are for use in hydraulic fluid power systems with hose that meets the requirements of the respective hose standards and in general applications with suitable hoses.

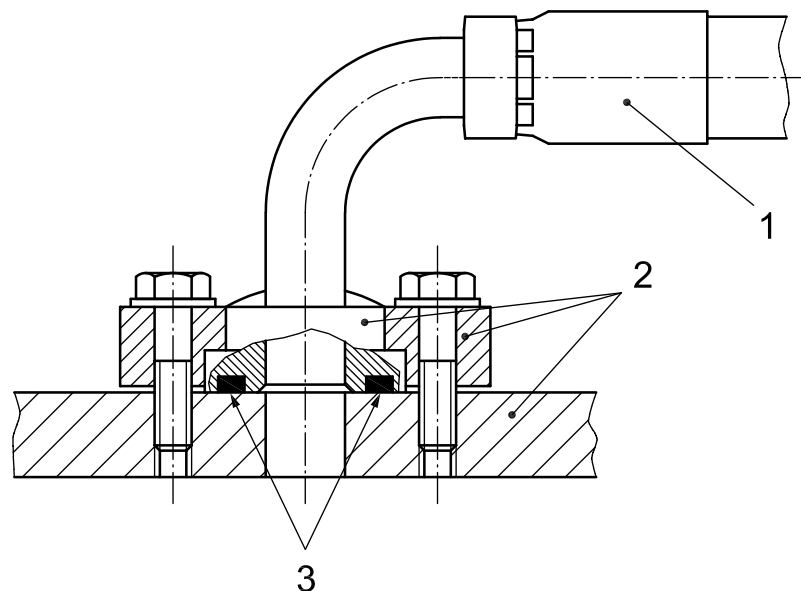

#### Key

- 1 hose fitting
- 2 port, flanged head and clamp per ISO 6162-1 or ISO 6162-2
- 3 O-ring seal

Figure 1 — Typical example of hose fitting connection with ISO 6162-1 or ISO 6162-2 flange end

## 2 Normative references

The following referenced documents are indispensable for the application of this document. For dated references, only the edition cited applies. For undated references, the latest edition of the referenced document (including any amendments) applies.

ISO 4397, *Fluid power systems and components — Connectors and associated components — Nominal outside diameters of tubes and nominal inside diameters of hoses*

ISO 5598, *Fluid power systems and components — Vocabulary*

ISO 6162-1, *Hydraulic fluid power — Flange connectors with split or one-piece flange clamps and metric or inch screws — Part 1: Flange connectors for use at pressures of 3,5 MPa (35 bar) to 35 MPa (350 bar), DN 13 to DN 127*

ISO 6162-2, *Hydraulic fluid power — Flange connectors with split or one-piece flange clamps and metric or inch screws — Part 2: Flange connectors for use at pressures of 35 MPa (350 bar) to 40 MPa (400 bar), DN 13 to DN 51*

ISO 6605, *Hydraulic fluid power — Hoses and hose assemblies — Test methods*

ISO 9227, *Corrosion tests in artificial atmospheres — Salt spray tests*

ISO 19879, *Metallic tube connections for fluid power and general use — Test methods for hydraulic fluid power connections*

## 3 Terms and definitions

For the purposes of this document, the terms and definitions given in ISO 5598 apply.

## 4 Performance requirements

**4.1** Hose assemblies shall meet the performance requirements specified in the appropriate hose specification without leakage or failure.

**4.2** The working pressure of the hose assembly shall be the lower of the pressures given for its flange style (pressure series) and size in ISO 6162-1 or ISO 6162-2, and in the relevant hose specification.

**4.3** The hose-fitting portion of a hose assembly shall be tested in accordance with ISO 19879, and the complete hose assembly shall be tested in accordance with ISO 6605.

## 5 Designation of hose fittings

**5.1** Hose fittings shall be designated by an alphanumeric code to facilitate ordering. They shall be designated by the words “Hose fitting”, followed by a space, followed by “ISO 12151-3”, followed by a spaced hyphen, then the shape symbol (see 5.2), followed by another spaced hyphen, the style letter L for 2,5 MPa to 35 MPa (25 bar to 350 bar) flanges or the style letter S for 40 MPa (400 bar) flanges in accordance with ISO 6162-1 or ISO 6162-2, followed by the flange size from ISO 6162-1 or ISO 6162-2, a multiplication symbol (×) and the hose size (nominal hose inside diameter in accordance with ISO 4397).

**EXAMPLE** A 45° elbow hose fitting, with a medium drop length (E45M) with a 40 MPa (400 bar) flanged head (S) 32 mm nominal flange size and 31,5 nominal ID hose, is designated as follows:

**Hose fitting ISO 12151-3 - E45M - S32 × 31,5**

**5.2** The letter symbols as given in Table 1 shall be used.



Table 1 — Letter symbols used in the designation of hose fittings

Connection end type		Symbol
Style	2,5 MPa to 35 MPa (25 bar to 350 bar)	L
	40 MPa (400 bar)	S
Shape	Straight	S
	45° elbow, short	E45S
	45° elbow, medium	E45M
	90° elbow, short	ES
	90° elbow, medium	EM
	Deprecated fitting angles	22,5° elbow, medium
	30° elbow, short	E30S
	30° elbow, medium	E30M
	60° elbow, short	E60S
	60° elbow, medium	E60M
	67,5° elbow, short	E67S
	67,5° elbow, medium	E67M

## 6 Design

**6.1** Hose fitting dimensions shown in Figures 2 to 8 shall conform to those given in Tables 2 to 8 and to the relevant dimensions in ISO 6162-1 or ISO 6162-2.

**6.2** Angular tolerances on axes of ends of elbows shall be  $\pm 3^\circ$  for all sizes.

**6.3** Details of contour shall be as chosen by the manufacturer, provided that the dimensions given in Tables 2 to 8 are maintained.

## 7 Manufacture

### 7.1 Construction

Hose fittings may be made by forging or cold forming, machined from barstock or manufactured from multiple components.

### 7.2 Workmanship

Workmanship shall conform to the best commercial practice to produce high quality hose fittings. Hose fittings shall be free from visual contaminants, all hanging burrs, loose scale and slivers that can be dislodged in use, and any other defects that can affect the functioning of the parts. All machined surfaces shall have a surface roughness value of  $Ra \leq 6,3 \mu\text{m}$ , except where otherwise specified.

### 7.3 Finish

The external surface and threads of all carbon steel parts shall be plated or coated with a suitable material that passes a 72 h neutral salt spray test in accordance with ISO 9227, unless otherwise agreed upon by the

## ISO 12151-3:2010(E)

manufacturer and the user. Any appearance of red rust during the salt spray test on any area, except those noted below, shall be considered failure:

- all internal fluid passages;
- edges, such as hex points, serrations and crests of threads, where there can be mechanical deformation of the plating or coating typical of mass-produced parts or shipping effects;
- areas where there is mechanical deformation of the plating or coating caused by crimping, flaring, bending and other post-plate metal forming operations;
- areas where the parts are suspended or affixed in the test chamber where condensate can accumulate.

Internal fluid passages shall be protected from corrosion during storage.

NOTE Cadmium plating is deprecated due to environmental concerns. Changes in plating can affect assembly torques and require requalification, when applicable.

### 7.4 Fitting protection

By a method agreed between the supplier and purchaser, the face of the flange hose fittings shall be protected by the manufacturer from nicks and scratches that can be detrimental to the functioning of the hose fitting. Passages shall be securely covered to prevent the entrance of dirt or other contaminants. Covers that contribute to contamination shall not be used.

## 8 Procurement information

The following minimum information should be supplied by the purchaser when making an inquiry or placing an order:

- description of hose fitting using designation in accordance with Clause 5;
- material of hose fitting if other than carbon steel;
- hose type and size;
- fluid being conveyed;
- working pressure;
- working temperature (ambient and of the fluid).

## 9 Marking

Hose fittings shall be permanently marked with the manufacturer's name or trademark.

## 10 Identification statement (reference to this part of ISO 12151)

It is strongly recommended to manufacturers who have chosen to conform to this part of ISO 12151 that the following statement be used in test reports, catalogues and sales literature:

“Flange hose fittings conform to ISO 12151-3, *Connections for hydraulic fluid power and general use — Hose fittings — Part 3: Hose fittings with ISO 6162-1 or ISO 6162-2 flange ends.*”

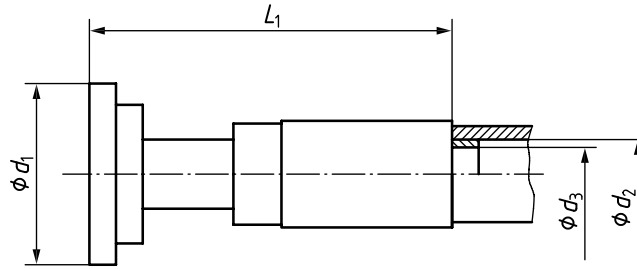

NOTE 1 Connection details and O-rings in accordance with ISO 6162-1 or ISO 6162-2.

NOTE 2 Method of attachment of hose fitting to hose is optional.

Figure 2 — Straight flange hose fittings (S)

Table 2 — Dimensions of straight flange hose fittings (S)

Dimensions in millimetres

Hose fitting size	$d_1$ $\pm 0,25$		Nominal flange size	Nominal hose inside diameter $d_2$	$d_3^a$ min.	$L_1^b$ max.
	S-L	S-S				
13 × 12,5	30,2	31,8	13	12,5	8	100
19 × 12,5	38,1	41,3	19	12,5	8	120
19 × 19	38,1	41,3	19	19	14	140
25 × 19	44,45	47,6	25	19	14	150
25 × 25	44,45	47,6	25	25	19	150
32 × 25	50,8	54	32	25	19	163
32 × 31,5	50,8	54	32	31,5	25	175
38 × 31,5	60,35	63,5	38	31,5	25	182
38 × 38	60,35	63,5	38	38	31	200
51 × 38	71,4	79,4	51	38	31	220
51 × 51	71,4	79,4	51	51	42	240

<sup>a</sup> Minimum diameter at any point through the hose fitting prior to assembly to the hose. The diameter after assembly shall not be less than  $0,9d_3$ .

<sup>b</sup> Dimension  $L_1$  is measured after assembly.

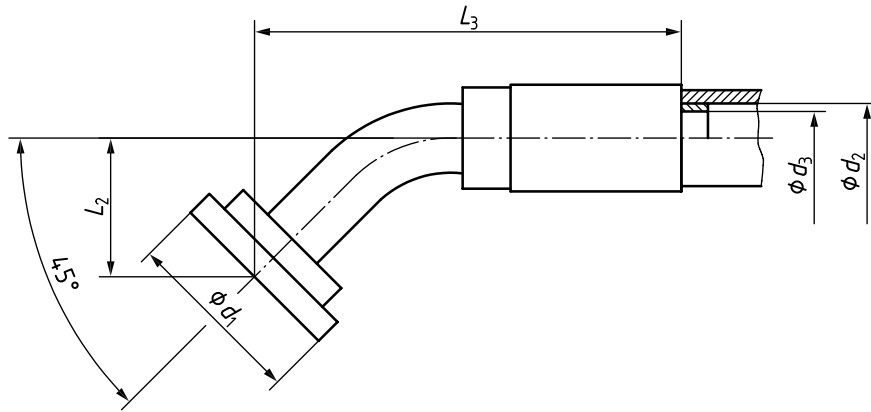

NOTE 1 Connection details and O-rings in accordance with ISO 6162-1 or ISO 6162-2.

NOTE 2 Method of attachment of hose fitting to hose is optional.

Figure 3 — 45° elbow flange hose fittings (E45)

Table 3 — Dimensions of 45° elbow flange hose fittings (E45)

Dimensions in millimetres

Hose fitting size	$d_1$ $\pm 0,25$		Nominal flange size	Nominal hose inside diameter $d_2$	$d_3^a$ min.	$L_2$ $\pm 3$		$L_3^b$ max.
	E45S-L E45M-L	E45S-S E45M-S				E45S-L <sup>c</sup> E45S-S <sup>c</sup>	E45M-L E45M-S	
13 × 12,5	30,2	31,8	13	12,5	8	—	19	105
19 × 12,5	38,1	41,3	19	12,5	8	—	26	125
19 × 19	38,1	41,3	19	19	14	—	26	145
25 × 19	44,45	47,6	25	19	14	—	32	175
25 × 25	44,45	47,6	25	25	19	28 <sup>c</sup>	32	175
32 × 25	50,8	54	32	25	19	32 <sup>c</sup>	38	188
32 × 31,5	50,8	54	32	31,5	25	32 <sup>c</sup>	38	200
38 × 31,5	60,35	63,5	38	31,5	25	38 <sup>c</sup>	44	222
38 × 38	60,35	63,5	38	38	31	38 <sup>c</sup>	44	240
51 × 38	71,4	79,4	51	38	31	52 <sup>c</sup>	56	270
51 × 51	71,4	79,4	51	51	42	52 <sup>c</sup>	56	290

<sup>a</sup> Minimum diameter at any point through the hose fitting prior to bending and/or assembly to the hose. The diameter after bending and/or assembly shall not be less than  $0,9d_3$ .

<sup>b</sup> Dimension  $L_3$  is measured after assembly.

<sup>c</sup> Short-drop (E45S-L and E45S-S) hose fittings might not be manufactured by preferred methods with ratings suitable for use with high-pressure spiral-wire hose, which is typically used at working pressures of 28 MPa (280 bar), 21 MPa (210 bar), 17,5 MPa (175 bar) or 14 MPa (140 bar) and higher in hose sizes 25, 31,5, 38 and 51, respectively. Use preferred medium-drop (E45M-L or E45M-S) hose fittings or consult manufacturer for availability.

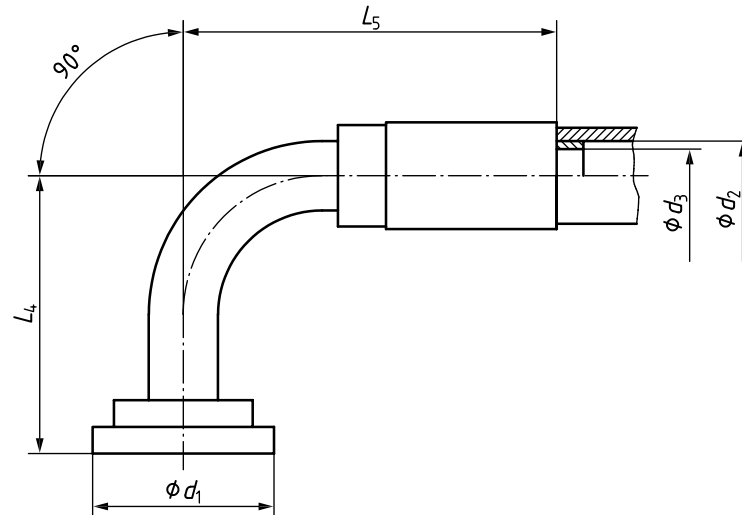

NOTE 1 Connection details and O-rings in accordance with ISO 6162-1 or ISO 6162-2.

NOTE 2 Method of attachment of hose fitting to hose is optional.

Figure 4 — 90° elbow flange hose fittings (E)

Table 4 — Dimensions of 90° elbow flange hose fittings (E)

Dimensions in millimetres

Hose fitting size	$d_1$ $\pm 0,25$		Nominal flange size	Nominal hose inside diameter $d_2$	$d_3^a$ min.	$L_4$ $\pm 3$		$L_5^b$ max.
	ES-L EM-L	ES-S EM-S				ES-L <sup>c</sup> ES-S <sup>c</sup>	EM-L EM-S	
13 × 12,5	30,2	31,8	13	12,5	8	—	40	100
19 × 12,5	38,1	41,3	19	12,5	8	—	58	120
19 × 19	38,1	41,3	19	19	14	—	58	140
25 × 19	44,45	47,6	25	19	14	—	70	170
25 × 25	44,45	47,6	25	25	19	61	70	170
32 × 25	50,8	54	32	25	19	68 <sup>c</sup>	90	188
32 × 31,5	50,8	54	32	31,5	25	68 <sup>c</sup>	90	200
38 × 31,5	60,35	63,5	38	31,5	25	81 <sup>c</sup>	104	212
38 × 38	60,35	63,5	38	38	31	81 <sup>c</sup>	104	230
51 × 38	71,4	79,4	51	38	31	120 <sup>c</sup>	138	260
51 × 51	71,4	79,4	51	51	42	120 <sup>c</sup>	138	280

<sup>a</sup> Minimum diameter at any point through the hose fitting prior to bending and/or assembly to the hose. The diameter after bending and/or assembly shall not be less than  $0,9d_3$ .

<sup>b</sup> Dimension  $L_5$  is measured after assembly.

<sup>c</sup> Short-drop (ES-L and ES-S) hose fittings in flange sizes 32 and larger might not be manufactured by preferred methods with ratings suitable for use with high-pressure spiral-wire hose, which is typically used at working pressures of 28 MPa (280 bar), 21 MPa (210 bar), 17,5 MPa (175 bar) or 14 MPa (140 bar) and higher in hose sizes 25, 31,5, 38 and 51, respectively. Use preferred medium-drop (EM-L or EM-S) hose fittings or consult manufacturer for availability.

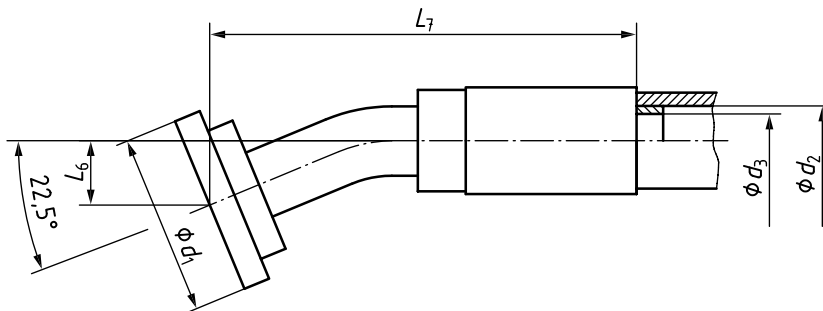

NOTE 1 Connection details and O-rings in accordance with ISO 6162-1 or ISO 6162-2.

NOTE 2 Method of attachment of hose fitting to hose is optional.

NOTE 3 This hose fitting angle is not preferred.

Figure 5 — 22,5° elbow flange hose fittings (E22)

Table 5 — Dimensions of 22,5° elbow flange hose fittings (E22)

Dimensions in millimetres

Hose fitting size	$d_1$ $\pm 0,25$		Nominal flange size	Nominal hose inside diameter $d_2$	$d_3^a$ min.	$L_6$ $\pm 3$	$L_7^b$ max.
	E22M-L	E22M-S				E22M-L E22M-S	
13 × 12,5	30,2	31,8	13	12,5	8	9	105
19 × 12,5	38,1	41,3	19	12,5	8	11	115
19 × 19	38,1	41,3	19	19	14	11	135
25 × 19	44,45	47,6	25	19	14	14	170
25 × 25	44,45	47,6	25	25	19	14	170
32 × 25	50,8	54	32	25	19	15	193
32 × 31,5	50,8	54	32	31,5	25	15	205
38 × 31,5	60,35	63,5	38	31,5	25	18	232
38 × 38	60,35	63,5	38	38	31	18	250
51 × 38	71,4	79,4	51	38	31	22	285
51 × 51	71,4	79,4	51	51	42	22	305

<sup>a</sup> Minimum diameter at any point through the hose fitting prior to bending and/or assembly to the hose. The diameter after bending and/or assembly shall not be less than  $0,9d_3$ .

<sup>b</sup> Dimension  $L_7$  is measured after assembly.

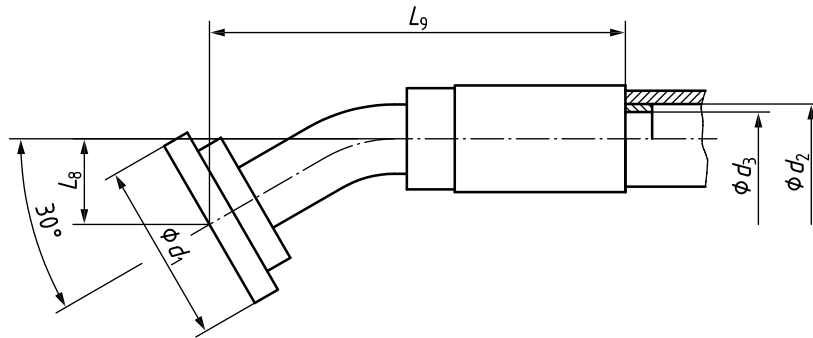

NOTE 1 Connection details and O-rings in accordance with ISO 6162-1 or ISO 6162-2.

NOTE 2 Method of attachment of hose fitting to hose is optional.

NOTE 3 This hose fitting angle is not preferred.

Figure 6 — 30° elbow flange hose fittings (E30)

Table 6 — Dimensions of 30° elbow flange hose fittings (E30)

Dimensions in millimetres

Hose fitting size	$d_1$ $\pm 0,25$		Nominal flange size	Nominal hose inside diameter $d_2$	$d_3^a$ min.	$L_8$ $\pm 3$		$L_9^b$ max.
	E30S-L E30M-L	E30S-S E30M-S				E30S-L <sup>c</sup> E30S-S <sup>c</sup>	E30M-L E30M-S	
13 × 12,5	30,2	31,8	13	12,5	8	—	12	105
19 × 12,5	38,1	41,3	19	12,5	8	—	16	125
19 × 19	38,1	41,3	19	19	14	—	16	145
25 × 19	44,45	47,6	25	19	14	—	19	170
25 × 25	44,45	47,6	25	25	19	—	19	170
32 × 25	50,8	54	32	25	19	—	22	188
32 × 31,5	50,8	54	32	31,5	25	20 <sup>c</sup>	22	200
38 × 31,5	60,35	63,5	38	31,5	25	—	30	227
38 × 38	60,35	63,5	38	38	31	25 <sup>c</sup>	30	245
51 × 38	71,4	79,4	51	38	31	—	32	280
51 × 51	71,4	79,4	51	51	42	—	32	300

<sup>a</sup> Minimum diameter at any point through the hose fitting prior to bending and/or assembly to the hose. The diameter after bending and/or assembly shall not be less than  $0,9d_3$ .

<sup>b</sup> Dimension  $L_9$  is measured after assembly.

<sup>c</sup> Short-drop (E30S-L and E30S-S) hose fittings might not be manufactured by preferred methods with ratings suitable for use with high pressure spiral wire hose, which is typically used at working pressures of 21 MPa (210 bar) or 17,5 MPa (175 bar) and higher in hose sizes 31,5 and 38, respectively. Use preferred medium-drop (E30M-L or E30M-S) hose fittings or consult manufacturer for availability.

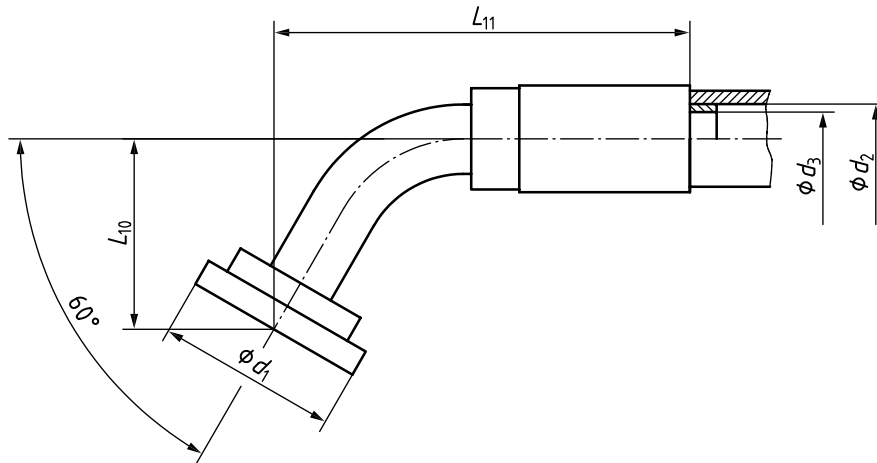

NOTE 1 Connection details and O-rings in accordance with ISO 6162-1 or ISO 6162-2.

NOTE 2 Method of attachment of hose fitting to hose is optional.

NOTE 3 This hose fitting angle is not preferred.

Figure 7 — 60° elbow flange hose fittings (E60)

Table 7 — Dimensions of 60° elbow flange hose fittings (E60)

Dimensions in millimetres

Hose fitting size	$d_1$ $\pm 0,25$		Nominal flange size	Nominal hose inside diameter $d_2$	$d_3^a$ min.	$L_{10}$ $\pm 3$		$L_{11}^b$ max.
	E60S-L E60M-L	E60S-S E60M-S				E60S-L <sup>c</sup> E60S-S <sup>c</sup>	E60M-L E60M-S	
13 × 12,5	30,2	31,8	13	12,5	8	—	27	110
19 × 12,5	38,1	41,3	19	12,5	8	—	37	125
19 × 19	38,1	41,3	19	19	14	—	37	145
25 × 19	44,45	47,6	25	19	14	—	44	180
25 × 25	44,45	47,6	25	25	19	—	44	180
32 × 25	50,8	54	32	25	19	—	55	218
32 × 31,5	50,8	54	32	31,5	25	45 <sup>c</sup>	55	230
38 × 31,5	60,35	63,5	38	31,5	25	—	64	262
38 × 38	60,35	63,5	38	38	31	53 <sup>c</sup>	64	280
51 × 38	71,4	79,4	51	38	31	—	83	290
51 × 51	71,4	79,4	51	51	42	75 <sup>c</sup>	83	310

<sup>a</sup> Minimum diameter at any point through the hose fitting prior to bending and/or assembly to the hose. The diameter after bending and/or assembly shall not be less than  $0,9d_3$ .

<sup>b</sup> Dimension  $L_{11}$  is measured after assembly.

<sup>c</sup> Short-drop (E60S-L and E60S-S) hose fittings might not be manufactured by preferred methods with ratings suitable for use with high pressure spiral wire hose, which is typically used at working pressures of 21 MPa (210 bar), 17,5 MPa (175 bar) or 14 MPa (140 bar) and higher in hose sizes 31,5, 38 and 51, respectively. Use preferred medium-drop (E60M-L or E60M-S) hose fittings or consult manufacturer for availability.



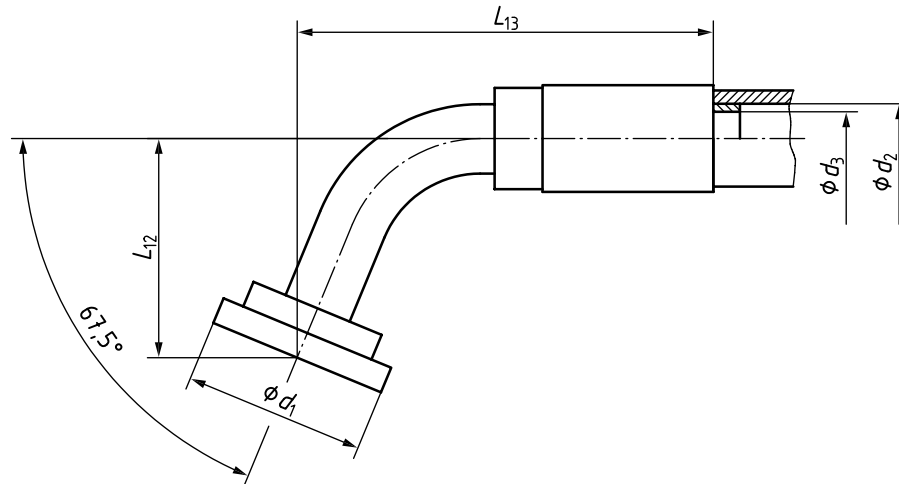

NOTE 1 Connection details and O-rings in accordance with ISO 6162-1 or ISO 6162-2.

NOTE 2 Method of attachment of hose fitting to hose is optional.

NOTE 3 This hose fitting angle is not preferred.

Figure 8 — 67,5° elbow flange hose fittings (E67)

Table 8 — Dimensions of 67,5° elbow flange hose fittings (E67)

Dimensions in millimetres

Hose fitting size	$d_1$ ±0,25		Nominal flange size	Nominal hose inside diameter $d_2$	$d_3^a$ min.	$L_{12}$ ±3		$L_{13}^b$ max.
	E67S-L E67M-L	E67S-S E67M-S				E67S-L <sup>c</sup> E67S-S <sup>c</sup>	E67M-L E67M-S	
13 × 12,5	30,2	31,8	13	12,5	8	—	30	105
19 × 12,5	38,1	41,3	19	12,5	8	—	42	125
19 × 19	38,1	41,3	19	19	14	—	42	145
25 × 19	44,45	47,6	25	19	14	—	51	175
25 × 25	44,45	47,6	25	25	19	—	51	175
32 × 25	50,8	54	32	25	19	—	64	208
32 × 31,5	50,8	54	32	31,5	25	51 <sup>c</sup>	64	220
38 × 31,5	60,35	63,5	38	31,5	25	—	74	242
38 × 38	60,35	63,5	38	38	31	61 <sup>c</sup>	74	260
51 × 38	71,4	79,4	51	38	31	—	97	280
51 × 51	71,4	79,4	51	51	42	85 <sup>c</sup>	97	300

<sup>a</sup> Minimum diameter at any point through the hose fitting prior to bending and/or assembly to the hose. The diameter after bending and/or assembly shall not be less than  $0,9d_3$ .

<sup>b</sup> Dimension  $L_{13}$  is measured after assembly.

<sup>c</sup> Short-drop (E67S-L and E67S-S) hose fittings might not be manufactured by preferred methods with ratings suitable for use with high pressure spiral wire hose, which is typically used at working pressures of 21 MPa (210 bar), 17,5 MPa (175 bar) or 14 MPa (140 bar) and higher in hose sizes 31,5, 38 and 51, respectively. Use preferred medium-drop (E67M-L or E67M-S) hose fittings or consult manufacturer for availability.

## Bibliography

- [1] ISO 1436, *Rubber hoses and hose assemblies — Wire-braid-reinforced hydraulic types for oil-based or water-based fluids — Specification*
- [2] ISO 3862, *Rubber hoses and hose assemblies — Rubber-covered spiral-wire-reinforced hydraulic types for oil-based or water-based fluids — Specification*
- [3] ISO 3949, *Plastics hoses and hose assemblies — Textile-reinforced types for hydraulic applications — Specification*
- [4] ISO 4038, *Road vehicles — Hydraulic braking systems — Simple flare pipes, tapped holes, male fittings and hose end fittings*
- [5] ISO 4039-1, *Road vehicles — Pneumatic braking systems — Part 1: Pipes, male fittings and tapped holes with facial sealing surface*
- [6] ISO 4039-2, *Road vehicles — Pneumatic braking systems — Part 2: Pipes, male fittings and holes with conical sealing surface*
- [7] ISO 4079, *Rubber hoses and hose assemblies — Textile-reinforced hydraulic types for oil-based or water-based fluids — Specification*

.....

---

---

**ICS 23.040.70; 23.100.40**

Price based on 12 pages