

---

---

**Connections for hydraulic fluid power  
and general use — Hose fittings —**

Part 2:

**Hose fittings with ISO 8434-1 and  
ISO 8434-4 24° cone connector ends with  
O-rings**

*Raccordements pour transmissions hydrauliques et applications  
générales — Flexibles de raccordement —*

*Partie 2: Flexibles avec embouts à cône à 24° et joints toriques  
conformes à l'ISO 8434-1 et à l'ISO 8434-4*



**PDF disclaimer**

This PDF file may contain embedded typefaces. In accordance with Adobe's licensing policy, this file may be printed or viewed but shall not be edited unless the typefaces which are embedded are licensed to and installed on the computer performing the editing. In downloading this file, parties accept therein the responsibility of not infringing Adobe's licensing policy. The ISO Central Secretariat accepts no liability in this area.

Adobe is a trademark of Adobe Systems Incorporated.

Details of the software products used to create this PDF file can be found in the General Info relative to the file; the PDF-creation parameters were optimized for printing. Every care has been taken to ensure that the file is suitable for use by ISO member bodies. In the unlikely event that a problem relating to it is found, please inform the Central Secretariat at the address given below.

© ISO 2003

All rights reserved. Unless otherwise specified, no part of this publication may be reproduced or utilized in any form or by any means, electronic or mechanical, including photocopying and microfilm, without permission in writing from either ISO at the address below or ISO's member body in the country of the requester.

ISO copyright office  
Case postale 56 • CH-1211 Geneva 20  
Tel. + 41 22 749 01 11  
Fax + 41 22 749 09 47  
E-mail [copyright@iso.org](mailto:copyright@iso.org)  
Web [www.iso.org](http://www.iso.org)

Published in Switzerland

# Contents

Page

<b>Foreword</b> .....	<b>iv</b>
<b>Introduction</b> .....	<b>v</b>
<b>1 Scope</b> .....	<b>1</b>
<b>2 Normative references</b> .....	<b>1</b>
<b>3 Terms and definitions</b> .....	<b>2</b>
<b>4 Performance requirements</b> .....	<b>2</b>
<b>5 Designation of hose fittings</b> .....	<b>3</b>
<b>6 Design</b> .....	<b>3</b>
<b>7 Manufacture</b> .....	<b>3</b>
<b>8 Assembly instructions</b> .....	<b>4</b>
<b>9 Procurement information</b> .....	<b>5</b>
<b>10 Marking</b> .....	<b>5</b>
<b>11 Identification statement</b> (Reference to this part of ISO 12151) .....	<b>5</b>
<b>Bibliography</b> .....	<b>13</b>

## Foreword

ISO (the International Organization for Standardization) is a worldwide federation of national standards bodies (ISO member bodies). The work of preparing International Standards is normally carried out through ISO technical committees. Each member body interested in a subject for which a technical committee has been established has the right to be represented on that committee. International organizations, governmental and non-governmental, in liaison with ISO, also take part in the work. ISO collaborates closely with the International Electrotechnical Commission (IEC) on all matters of electrotechnical standardization.

International Standards are drafted in accordance with the rules given in the ISO/IEC Directives, Part 2.

The main task of technical committees is to prepare International Standards. Draft International Standards adopted by the technical committees are circulated to the member bodies for voting. Publication as an International Standard requires approval by at least 75 % of the member bodies casting a vote.

Attention is drawn to the possibility that some of the elements of this document may be the subject of patent rights. ISO shall not be held responsible for identifying any or all such patent rights.

ISO 12151-2 was prepared by Technical Committee ISO/TC 131, *Fluid power systems*, Subcommittee SC 4, *Connectors and similar products and components*.

ISO 12151 consists of the following parts, under the general title *Connections for hydraulic fluid power and general use — Hose fittings*:

- *Part 1: Hose fittings with ISO 8434-3 O-ring face seal ends*
- *Part 2: Hose fittings with ISO 8434-1 and ISO 8434-4 24° cone connector ends with O-rings*
- *Part 3: Hose fittings with ISO 6162 flange ends*
- *Part 4: Hose fittings with ISO 6149 metric stud ends*
- *Part 5: Hose fittings with ISO 8434-2 37° flared ends*
- *Part 6: Hose fittings with ISO 8434-6 60° cone ends*

## Introduction

In hydraulic fluid power systems, power is transmitted and controlled through a liquid under pressure within an enclosed circuit. In general applications, a fluid may be conveyed under pressure.

Components are connected through their ports by stud ends on fluid conductor fittings to tubes/pipes or to hose fittings and hoses.

.....

# Connections for hydraulic fluid power and general use — Hose fittings —

## Part 2: Hose fittings with ISO 8434-1 and ISO 8434-4 24° cone connector ends with O-rings

### 1 Scope

This part of ISO 12151 specifies the general and dimensional requirements for the design and performance of hose fittings with 24° cone connector ends with O-rings, in accordance with ISO 8434-1 and ISO 8434-4. These hose fittings are made of carbon steel and are intended for use with hoses with nominal inside diameters from 5 mm through 38 mm (inclusive).

NOTE 1 Materials other than carbon steel may be supplied as agreed between the manufacturer and user.

NOTE 2 For hose fittings used in hydraulic and pneumatic braking systems on road vehicles (as defined in the scope of ISO/TC 22), see ISO 4038, ISO 4039-1 and ISO 4039-2.

These hose fittings (see Figure 1 for a typical example) are for use in fluid power systems with hoses that meet the requirements of respective standards and in general applications with suitable hoses.

### 2 Normative references

The following referenced documents are indispensable for the application of this document. For dated references, only the edition cited applies. For undated references, the latest edition of the referenced document (including any amendments) applies.

ISO 4397, *Fluid power systems and components — Connectors and associated components — Nominal outside diameters of tubes and nominal inside diameters of hoses*

ISO 4759-1:2000, *Tolerances for fasteners — Part 1: Bolts, screws, studs and nuts — Product grades A, B and C*

ISO 5598, *Fluid power systems and components — Vocabulary*

ISO 8434-1<sup>1)</sup>, *Metallic tube connections for fluid power and general use — Part 1: 24° compression fittings*

ISO 8434-4<sup>1)</sup>, *Metallic tube connections for fluid power and general use — Part 4: 24° cone connectors with O-ring weld-on nipples*

ISO 8434-5<sup>2)</sup>, *Metallic tube connections for fluid power and general use — Part 5: Test methods for threaded hydraulic fluid power connections*

ISO 9227, *Corrosion tests in artificial atmospheres — Salt spray tests*

1) The content of ISO 8434-4 will be incorporated into the revision of ISO 8434-1.

2) ISO 8434-5 is under revision and will be replaced by ISO 19879.

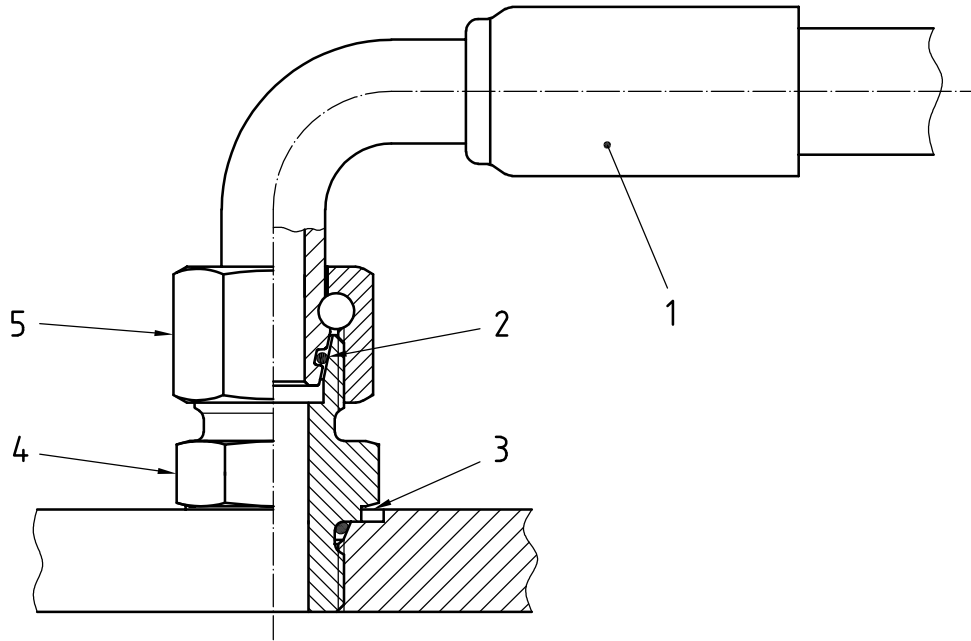

**Key**

- 1 hose fitting
- 2 O-ring seal
- 3 port
- 4 adapter
- 5 nut

**Figure 1 — Example of typical ISO 12151-2 hose fitting connection**

### **3 Terms and definitions**

For the purposes of this document, the terms and definitions given in ISO 5598 apply.

### **4 Performance requirements**

- 4.1** Hose assemblies shall meet the performance requirements specified in the appropriate hose specification without leakage or failure.
- 4.2** The working pressure of the hose assembly shall be the lower of the pressures given for its size in ISO 8434-1 or ISO 8434-4 and in the relevant hose specification.
- 4.3** Hose fitting tests shall be conducted in accordance with ISO 8434-5 for the working pressure of the hose assembly. The hose assembly shall undergo a cyclic endurance test and meet or exceed the number of cycles specified in the relevant hose specification.



## 5 Designation of hose fittings

**5.1** Hose fittings shall be designated by an alphanumeric code to facilitate ordering. They shall be designated by ISO 12151-2, followed by a spaced hyphen, then the connection end type, shape and style letter symbols (see 5.4), followed by another spaced hyphen and, for the ends, the letter symbol for the series directly followed by the 24° cone end size (nominal connection size) and the hose size (nominal hose inside diameter), each separated by a multiplication sign (×).

**EXAMPLE** A swivel straight light-duty series hose fitting for use with 22 mm OD tubing and 19 mm ID hose is designated as follows:

**ISO 12151-2 - SWS - L22 × 19**

**5.2** The letter symbol designation of the hose fitting shall consist of the connection end type, immediately followed by the shape of the fitting and the nut style, where applicable.

**5.3** Tube ends are assumed to be male and thus do not need to be included in the code. However, if another end is involved, it shall be designated.

**5.4** The following letter symbols shall be used:

Connection end type	Shape
Swivel / SW	Straight / S
	90° elbow / E
	45° elbow / E45
Series	Symbol
Light-duty	L
Heavy-duty	S

## 6 Design

**6.1** Hose fitting dimensions shown in Figures 2 to 5 shall conform to the dimensions in Tables 1 to 4 and to the relevant dimensions in ISO 8434-1 and ISO 8434-4.

**6.2** Hex tolerances across flats shall be in accordance with ISO 4759-1:2000, product grade C. Minimum across corner hex dimensions are 1,092 times the nominal width across flats. The minimum side flat is 0,43 times the nominal width across flats.

**6.3** Angular tolerances on axes of ends of elbows shall be  $\pm 3^\circ$  for all sizes.

**6.4** Details of contour shall be as chosen by the manufacturer, provided that the dimensions given in Tables 1 to 4 are maintained.

## 7 Manufacture

### 7.1 Construction

Hose fittings may be made by forging or cold forming, machined from bar stock or manufactured from multiple components.

## 7.2 Workmanship

Workmanship shall conform to the best commercial practice to produce high quality hose fittings. Hose fittings shall be free from visual contaminants, all hanging burrs, loose scale and slivers which might be dislodged in use, and any other defects that might affect the function of the parts. All machined surfaces shall have a surface roughness value of  $Ra \leq 6,3 \mu\text{m}$ , except where otherwise specified.

## 7.3 Finish

The external surface and threads of all carbon steel parts shall be plated or coated with a suitable material that passes a 72-h neutral salt spray test in accordance with ISO 9227, unless otherwise agreed upon by the manufacturer and the user. Any appearance of red rust during the salt spray test on any area, except those noted below, shall be considered failure:

- all internal fluid passages;
- edges, such as hex points, serrations and crests of threads, where there may be mechanical deformation of the plating or coating typical of mass-produced parts or shipping effects;
- areas where there is mechanical deformation of the plating or coating caused by crimping, flaring, bending and other post-plate metal forming operations;
- areas where the parts are suspended or affixed in the test chamber where condensate can accumulate.

Internal fluid passages shall be protected from corrosion during storage.

NOTE Cadmium plating is not preferred due to environmental concerns. Changes in plating can affect assembly torques and require requalification, when applicable.

## 7.4 Fitting protection

By a method agreed between the supplier and purchaser, the face of the hose fittings and threads (both internal and external) shall be protected by the manufacturer from nicks and scratches that would be detrimental to the function of the hose fitting. Passages shall be securely covered to prevent the entrance of dirt or other contaminants. Paper caps and plugs shall not be used.

## 8 Assembly instructions

The assembly of the hose fittings to other connectors or tubes shall be carried out without external loads. The manufacturer shall draw up assembly instructions for the use of hose fittings. These instructions shall include at least the following:

- instructions regarding the assembly of the hose fittings, such as the number of wrenching turns or assembly torque;
- recommendations regarding the tools to be used for assembly.

When hose fittings are used with tubes, follow the instructions related to material, preparation and attachment given in ISO 8434-1 or ISO 8434-4, as appropriate.

## 9 Procurement information

The following minimum information should be supplied by the purchaser when making an inquiry or placing an order:

- description of hose fitting (using designation in accordance with Clause 5);
- material of hose fitting (if other than carbon steel);
- hose type and size;
- fluid to be conveyed;
- working pressure;
- working temperature (ambient and of the fluid).

## 10 Marking

Hose fittings shall be permanently marked with the manufacturer's name or trademark. The nuts on female hose fittings shall be marked with the series (L or S) and hose fitting size.

## 11 Identification statement (Reference to this part of ISO 12151)

Use the following statement in test reports, catalogues and sales literature when electing to comply with this part of ISO 12151:

“Hose fitting with 24° compression fitting end and 24° cone connector end with O-ring in conformance to ISO 12151-2:2003, *Connections for hydraulic fluid power and general use — Hose fittings — Part 2: Hose fittings with ISO 8434-1 and ISO 8434-4 24° cone connector ends with O-rings.*”

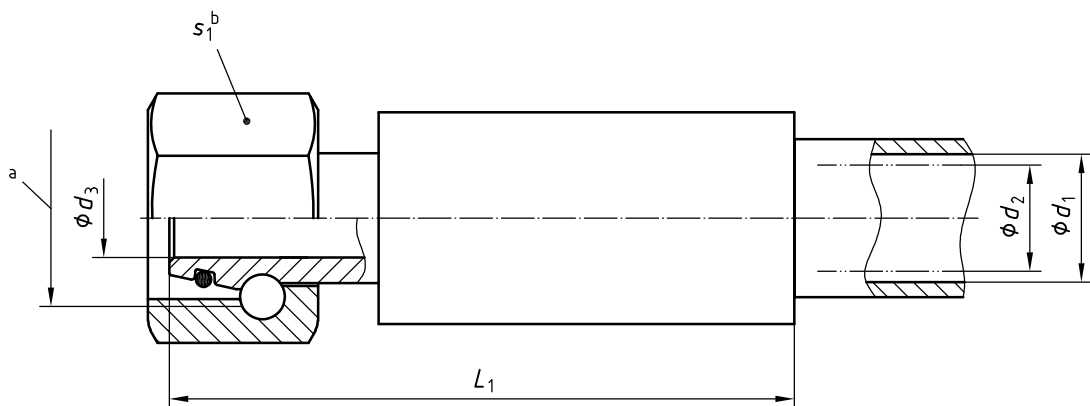

NOTE 1 A free length of tube should be left so that, in the case of an O-ring change, the nut can be moved behind the O-ring groove.

NOTE 2 Method of attachment of hose fitting to hose is optional.

NOTE 3 Connection details in accordance with ISO 8434-1 and ISO 8434-4.

a Thread.

b Width across flats.

**Figure 2 — Female straight swivel hose fitting (SWS)**

Table 1 — Dimensions of female straight swivel hose fittings (SWS)

Dimensions in millimetres

Series	Hose fitting size	Thread	Nominal connection size	Nominal hose ID	$d_2^b$ min.	$d_3^c$ max.	$s_1^d$	$L_1^e$ max.
				$d_1^a$				
Light-duty series (L)	6 × 5 <sup>f</sup>	M12 × 1,5	6	5	2,5	3,2	14	59
	8 × 6,3 <sup>f</sup>	M14 × 1,5	8	6,3	3	5,2	17	59
	10 × 8 <sup>f</sup>	M16 × 1,5	10	8	5	7,2	19	61
	12 × 10 <sup>f</sup>	M18 × 1,5	12	10	6	8,2	22	65
	15 × 12,5	M22 × 1,5	15	12,5	8	10,2	27	68
	18 × 16	M26 × 1,5	18	16	11	13,2	32	68
	22 × 19	M30 × 2	22	19	14	17,2	36	74
	28 × 25	M36 × 2	28	25	19	23,2	41	85
	35 × 31,5	M45 × 2	35	31,5	25	29,2	50	110
	42 × 38	M52 × 2	42	38	31	34,3	60	105
Heavy-duty series (S)	8 × 5	M16 × 1,5	8	5	2,5	4,2	19	59
	10 × 6,3	M18 × 1,5	10	6,3	3	6,2	22	67
	12 × 8	M20 × 1,5	12	8	5	8,2	24	68
	12 × 10	M20 × 1,5	12	10	6	8,2	24	72
	16 × 12,5	M24 × 1,5	16	12,5	8	11,2	30	80
	20 × 16	M30 × 2	20	16	11	14,2	36	93
	25 × 19	M36 × 2	25	19	14	18,2	46	102
	30 × 25	M42 × 2	30	25	19	23,2	50	112
	38 × 31,5	M52 × 2	38	31,5	25	30,3	60	126

<sup>a</sup> In accordance with ISO 4397.

<sup>b</sup> Minimum diameter at any point through the hose fitting prior to assembly to the hose. The diameter after assembly shall not be reduced by more than 10 %.

<sup>c</sup> Dimensions  $d_3$  are in accordance with ISO 8434-1, except that the minimum diameter for  $d_3$  shall not be less than  $d_2$ . Transition between diameters  $d_2$  (hose nipple through diameter) and  $d_3$  (through diameter of the connector end) shall be located to minimize stress concentration.

<sup>d</sup> Stem hex optional on female straight swivels (SWS).

<sup>e</sup> Dimension  $L_1$  is measured to the end of the crimped ferrule.

<sup>f</sup> Dimensions of cone connectors that are not included in current edition of ISO 8434-4.

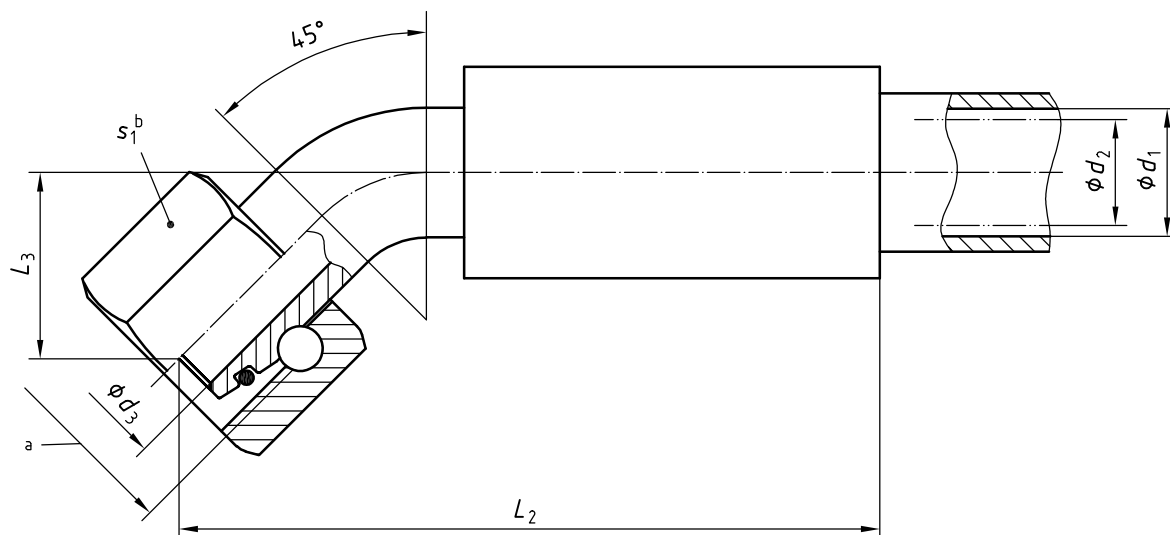

NOTE 1 A free length of tube should be left so that, in the case of an O-ring change, the nut can be moved behind the O-ring groove.

NOTE 2 Method of attachment of hose fitting to hose is optional.

NOTE 3 Connection details in accordance with ISO 8434-1.

a Thread.

b Width across flats.

**Figure 3 — Female 45° elbow swivel hose fitting (SWE45)**

Table 2 — Dimensions of female 45° elbow swivel hose fittings (SWE45)

Dimensions in millimetres

Series	Hose fitting size	Thread	Nominal connection size	Nominal hose ID $d_1^a$	$d_2^b$ min.	$d_3^c$ max.	$s_1$	$L_2^d$ max.	$L_3$	
									nom.	tol.
Light-duty series (L)	6 × 5 <sup>e</sup>	M12 × 1,5	6	5	2,5	3,2	14	80	15	± 3
	8 × 6,3 <sup>e</sup>	M14 × 1,5	8	6,3	3	5,2	17	80	16	± 4
	10 × 8 <sup>e</sup>	M16 × 1,5	10	8	5	7,2	19	80	17	± 4
	12 × 10 <sup>e</sup>	M18 × 1,5	12	10	6	8,2	22	90	18,5	± 4
	15 × 12,5	M22 × 1,5	15	12,5	8	10,2	27	100	19,5	± 4
	18 × 16	M26 × 1,5	18	16	11	13,2	32	110	23,5	± 6
	22 × 19	M30 × 2	22	19	14	17,2	36	130	25,5	± 6
	28 × 25	M36 × 2	28	25	19	23,2	41	133	32	± 6
	35 × 31,5	M45 × 2	35	31,5	25	29,2	50	165	38	± 7
	42 × 38	M52 × 2	42	38	31	34,3	60	185	44,5	± 10
Heavy-duty series (S)	8 × 5	M16 × 1,5	8	5	2,5	4,2	19	75	17	± 3
	10 × 6,3	M18 × 1,5	10	6,3	3	6,2	22	75	17	± 3
	12 × 8	M20 × 1,5	12	8	5	8,2	24	85	18	± 3
	12 × 10	M20 × 1,5	12	10	6	8,2	24	90	18,5	± 3
	16 × 12,5	M24 × 1,5	16	12,5	8	11,2	30	110	21	± 4
	20 × 16	M30 × 2	20	16	11	14,2	36	115	25	± 4
	25 × 19	M36 × 2	25	19	14	18,2	46	135	30,5	± 4
	30 × 25	M42 × 2	30	25	19	23,2	50	145	35,5	± 5
	38 × 31,5	M52 × 2	38	31,5	25	30,3	60	195	42	± 6

<sup>a</sup> In accordance with ISO 4397.

<sup>b</sup> Minimum diameter at any point through the hose fitting prior to assembly to the hose. The diameter after assembly shall not be reduced by more than 10 %. This definition does not apply to the bend.

<sup>c</sup> Dimensions  $d_3$  are in accordance with ISO 8434-1, except that the minimum diameter for  $d_3$  shall not be less than  $d_2$ . Transition between diameters  $d_2$  (hose nipple through diameter) and  $d_3$  (through diameter of the connector end) shall be located to minimize stress concentration.

<sup>d</sup> Dimension  $L_2$  is measured to the end of the crimped ferrule.

<sup>e</sup> Dimensions of cone connectors that are not included in the current edition of ISO 8434-4.

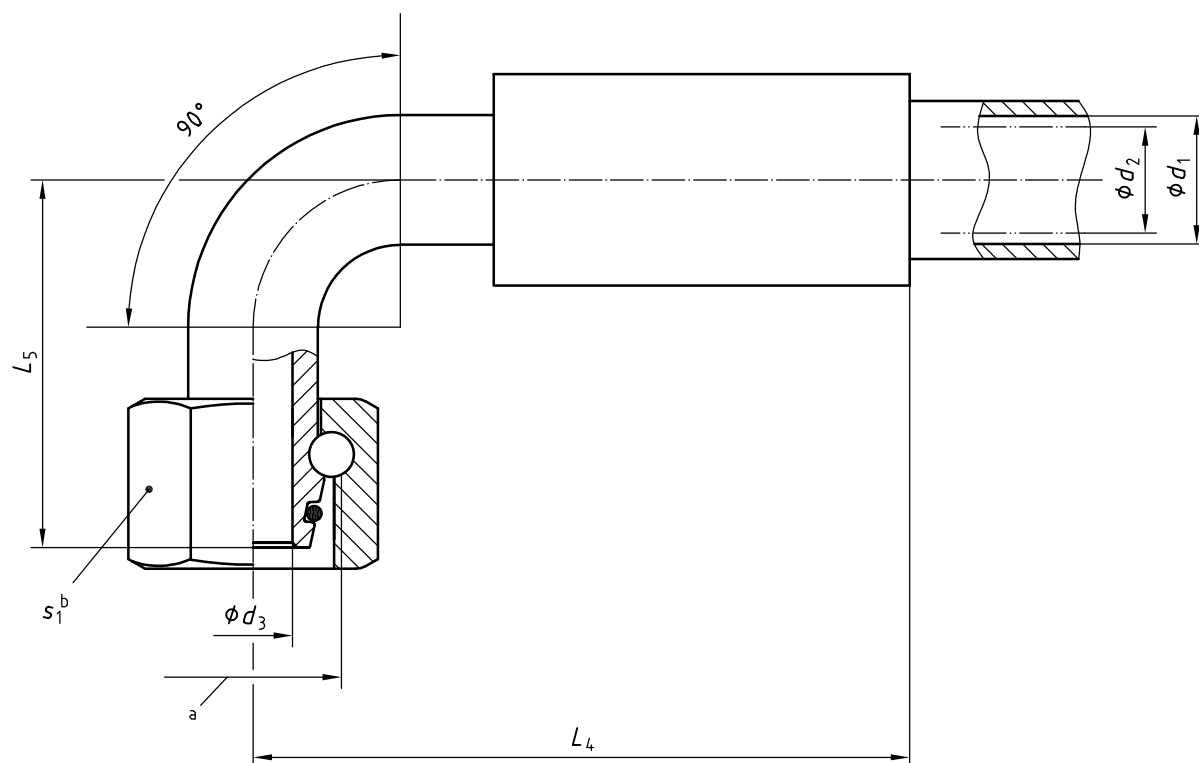

NOTE 1 A free length of tube should be left so that, in the case of an O-ring change, the nut can be moved behind the O-ring groove.

NOTE 2 Method of attachment of hose fitting to hose is optional.

NOTE 3 Connection details in accordance with ISO 8434-1.

a Thread.

b Width across flats.

Figure 4 — Female 90° elbow swivel hose fitting (SWE)

Table 3 — Dimensions of female 90° elbow swivel hose fittings (SWE)

Dimensions in millimetres

Series	Hose fitting size	Thread	Nominal connection size	Nominal hose ID $d_1^a$	$d_2^b$ min.	$d_3^c$ max.	$s_1$	$L_4^d$ max.	$L_5$	
									nom.	tol.
Light-duty series (L)	6 × 5 <sup>e</sup>	M12 × 1,5	6	5	2,5	3,2	14	65	30	± 5
	8 × 6,3 <sup>e</sup>	M14 × 1,5	8	6,3	3	5,2	17	65	30,5	± 5
	10 × 8 <sup>e</sup>	M16 × 1,5	10	8	5	7,2	19	75	33	± 5
	12 × 10 <sup>e</sup>	M18 × 1,5	12	10	6	8,2	22	85	36	± 5
	15 × 12,5	M22 × 1,5	15	12,5	8	10,2	27	90	40,5	± 6
	18 × 16	M26 × 1,5	18	16	11	13,2	32	95	51,5	± 10
	22 × 19	M30 × 2	22	19	14	17,2	36	100	56	± 10
	28 × 25	M36 × 2	28	25	19	23,2	41	120	68,5	± 10
	35 × 31,5	M45 × 2	35	31,5	25	29,2	50	147	78,5	± 10
	42 × 38	M52 × 2	42	38	31	36,2	60	170	95	± 13
Heavy-duty series (S)	8 × 5	M16 × 1,5	8	5	2,5	4,2	19	65	32	± 4
	10 × 6,3	M18 × 1,5	10	6,3	3	6,2	22	65	32	± 6
	12 × 8	M20 × 1,5	12	8	5	8,2	24	70	34	± 6
	12 × 10	M20 × 1,5	12	10	6	8,2	24	85	35,5	± 6
	16 × 12,5	M24 × 1,5	16	12,5	8	11,2	30	100	43	± 8
	20 × 16	M30 × 2	20	16	11	14,2	36	100	49,5	± 8
	25 × 19	M36 × 2	25	19	14	19,2	46	120	59	± 8
	30 × 25	M42 × 2	30	25	19	24,2	50	135	70	± 8
	38 × 31,5	M52 × 2	38	31,5	25	32,2	60	180	87	± 11

<sup>a</sup> In accordance with ISO 4397.

<sup>b</sup> Minimum diameter at any point through the hose fitting prior to assembly to the hose. The diameter after assembly shall not be reduced by more than 10 %. This definition does not apply to the bend.

<sup>c</sup> Dimensions  $d_3$  are in accordance with ISO 8434-1, except that the minimum diameter for  $d_3$  shall not be less than  $d_2$ . Transition between diameters  $d_2$  (hose nipple through diameter) and  $d_3$  (through diameter of the connector end) shall be located to minimize stress concentration.

<sup>d</sup> Dimension  $L_4$  is measured to the end of the crimped ferrule.

<sup>e</sup> Dimensions of cone connectors that are not included in the current edition of ISO 8434-4.



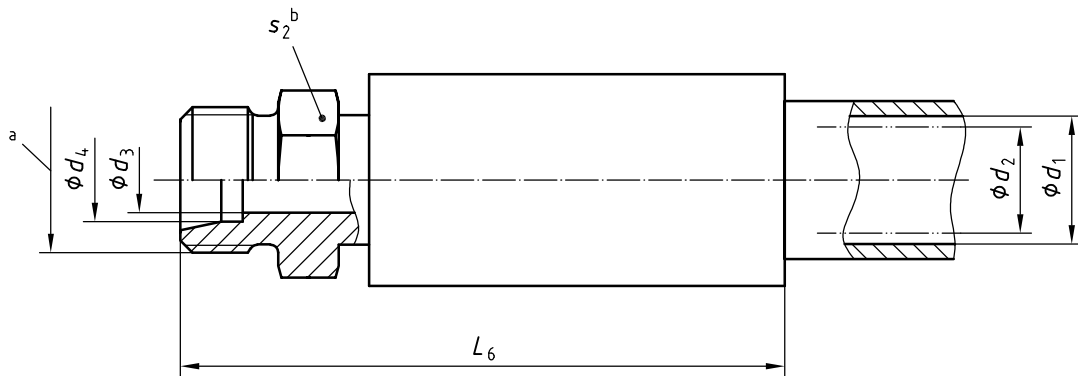

NOTE 1 Method of attachment of hose fitting to hose is optional.

NOTE 2 Connection details in accordance with ISO 8434-1.

- a Thread.
- b Width across flats.

**Figure 5 — Male straight hose fitting (S)**

Table 4 — Dimensions of male straight hose fittings (S)

Dimensions in millimetres

Series	Fitting size	Thread	Nominal connection size	Nominal hose ID $d_1^a$	$d_2^b$ min.	$d_3^{b,c}$ max.	$d_4^d$		$s_2^e$	$L_6^f$ max.
							B11	+0,1 0		
Light-duty series (L)	6 × 5 <sup>g</sup>	M12 × 1,5	6	5	2,5	4,2	6	—	14	59
	8 × 6,3 <sup>g</sup>	M14 × 1,5	8	6,3	3	6,2	8	—	17	59
	10 × 8 <sup>g</sup>	M16 × 1,5	10	8	5	8,2	10	—	17	60
	12 × 10 <sup>g</sup>	M18 × 1,5	12	10	6	10,2	12	—	19	62
	15 × 12,5	M22 × 1,5	15	12,5	8	12,2	15	—	24	70
	18 × 16	M26 × 1,5	18	16	11	15,2	18	—	27	75
	22 × 19	M30 × 2	22	19	14	19,2	22	—	32	78
	28 × 25	M36 × 2	28	25	19	24,2	28	—	41	90
	35 × 31,5	M45 × 2	35	31,5	25	30,3	—	35,3	46	108
42 × 38	M52 × 2	42	38	31	36,3	—	42,3	55	110	
Heavy-duty series (S)	8 × 5	M16 × 1,5	8	5	2,5	5,1	8	—	17	62
	10 × 6,3	M18 × 1,5	10	6,3	3	7,2	10	—	19	65
	12 × 8	M20 × 1,5	12	8	5	8,2	12	—	22	66
	12 × 10	M20 × 1,5	12	10	6	8,2	14	—	22	68
	16 × 12,5	M24 × 1,5	16	12,5	8	12,2	16	—	27	76
	20 × 16	M30 × 2	20	16	11	16,2	20	—	32	82
	25 × 19	M36 × 2	25	19	14	20,2	25	—	41	97
	30 × 25	M42 × 2	30	25	19	25,2	30	—	46	108
	38 × 31,5	M52 × 2	38	31,5	25	32,3	—	38,3	55	120

<sup>a</sup> In accordance with ISO 4397.

<sup>b</sup> Minimum diameter at any point through the hose fitting prior to assembly to the hose. The diameter after assembly shall not be reduced by more than 10 %.

<sup>c</sup> Dimensions  $d_3$  are in accordance with ISO 8434-1, except that the minimum diameter for  $d_3$  shall not be less than  $d_2$ . Transition between diameters  $d_2$  (hose nipple through diameter) and  $d_3$  (through diameter of the connector end) shall be located to minimize stress concentration.

<sup>d</sup> See ISO 8434-1.

<sup>e</sup> Smaller hexes are allowed.

<sup>f</sup> Dimension  $L_6$  is measured to the end of the crimped ferrule.

<sup>g</sup> Dimensions of cone connectors that are not included in the current edition of ISO 8434-4.

## Bibliography

- [1] ISO 1436-1, *Rubber hoses and hose assemblies — Wire-braid-reinforced hydraulic types — Specification — Part 1: Oil-based fluid applications*
- [2] ISO 3862-1, *Rubber hoses and hose assemblies — Rubber-covered spiral-wire-reinforced hydraulic types — Specification — Part 1: Oil-based fluid applications*
- [3] ISO 3949, *Plastics hoses and hose assemblies — Thermoplastics, textile-reinforced, hydraulic type — Specification*
- [4] ISO 4038, *Road vehicles — Hydraulic braking systems — Simple flare pipes, tapped holes, male fittings and hose end fittings*
- [5] ISO 4039-1, *Road vehicles — Pneumatic braking systems — Part 1: Pipes, male fittings and tapped holes with facial sealing surface*
- [6] ISO 4039-2, *Road vehicles — Pneumatic braking systems — Part 2: Pipes, male fittings and holes with conical sealing surface*
- [7] ISO 4079-1, *Rubber hoses and hose assemblies — Textile-reinforced hydraulic types — Specification — Part 1: Oil-based fluid applications*

---

---

**ICS 23.040.70; 23.100.40**

Price based on 13 pages