**Connections for hydraulic fluid power
and general use — Hose fittings —**

**Part 1:
Hose fittings with ISO 8434-3 O-ring face
seal ends**

*Raccordements pour transmissions hydrauliques et applications
générales — Raccords de flexible —*

*Partie 1: Raccords de flexible avec embouts à joints faciaux toriques
conformes à l'ISO 8434-3*



Reference number
ISO 12151-1:2010(E)

© ISO 2010

PDF disclaimer

This PDF file may contain embedded typefaces. In accordance with Adobe's licensing policy, this file may be printed or viewed but shall not be edited unless the typefaces which are embedded are licensed to and installed on the computer performing the editing. In downloading this file, parties accept therein the responsibility of not infringing Adobe's licensing policy. The ISO Central Secretariat accepts no liability in this area.

Adobe is a trademark of Adobe Systems Incorporated.

Details of the software products used to create this PDF file can be found in the General Info relative to the file; the PDF-creation parameters were optimized for printing. Every care has been taken to ensure that the file is suitable for use by ISO member bodies. In the unlikely event that a problem relating to it is found, please inform the Central Secretariat at the address given below.



COPYRIGHT PROTECTED DOCUMENT

© ISO 2010

All rights reserved. Unless otherwise specified, no part of this publication may be reproduced or utilized in any form or by any means, electronic or mechanical, including photocopying and microfilm, without permission in writing from either ISO at the address below or ISO's member body in the country of the requester.

ISO copyright office
Case postale 56 • CH-1211 Geneva 20
Tel. + 41 22 749 01 11
Fax + 41 22 749 09 47
E-mail copyright@iso.org
Web www.iso.org

Published in Switzerland

Contents

Page

Foreword	iv
Introduction	v
1 Scope	1
2 Normative references	2
3 Terms and definitions	2
4 Performance requirements	2
5 Designation of hose fittings	3
6 Design	3
7 Manufacture	4
8 Assembly instructions	4
9 Procurement information	5
10 Marking	5
11 Identification statement (reference to this part of ISO 12151)	5
Annex A (informative) Illustrations of applications for short, medium and long ISO 12151-1 hose fittings	14
Bibliography	15

Foreword

ISO (the International Organization for Standardization) is a worldwide federation of national standards bodies (ISO member bodies). The work of preparing International Standards is normally carried out through ISO technical committees. Each member body interested in a subject for which a technical committee has been established has the right to be represented on that committee. International organizations, governmental and non-governmental, in liaison with ISO, also take part in the work. ISO collaborates closely with the International Electrotechnical Commission (IEC) on all matters of electrotechnical standardization.

International Standards are drafted in accordance with the rules given in the ISO/IEC Directives, Part 2.

The main task of technical committees is to prepare International Standards. Draft International Standards adopted by the technical committees are circulated to the member bodies for voting. Publication as an International Standard requires approval by at least 75 % of the member bodies casting a vote.

Attention is drawn to the possibility that some of the elements of this document may be the subject of patent rights. ISO shall not be held responsible for identifying any or all such patent rights.

ISO 12151-1 was prepared by Technical Committee ISO/TC 131, *Fluid power systems*, Subcommittee SC 4, *Connectors and similar products and components*.

This second edition cancels and replaces the first edition (ISO 12151-1:1999), which has been technically revised.

ISO 12151 consists of the following parts, under the general title *Connections for hydraulic fluid power and general use — Hose fittings*:

- *Part 1: Hose fittings with ISO 8434-3 O-ring face seal ends*
- *Part 2: Hose fittings with ISO 8434-1 and ISO 8434-4 24° cone connector ends with O-rings*
- *Part 3: Hose fittings with ISO 6162-1 or ISO 6162-2 flange ends*
- *Part 4: Hose fittings with ISO 6149 metric stud ends*
- *Part 5: Hose fittings with ISO 8434-2 37° flared ends*
- *Part 6: Hose fittings with ISO 8434-6 60° cone ends*

Introduction

In hydraulic fluid power systems, power is transmitted and controlled through a liquid under pressure within an enclosed circuit. In general applications, the fluid can be conveyed under pressure.

Components are connected through their ports by stud ends on fluid conductor connectors to tubes/pipes or to hose fittings and hoses.

.....

Connections for hydraulic fluid power and general use — Hose fittings —

Part 1: Hose fittings with ISO 8434-3 O-ring face seal ends

1 Scope

This part of ISO 12151 specifies the general and dimensional requirements for the design and performance of hose fittings with O-ring face seal ends in accordance with ISO 8434-3, made of carbon steel, for nominal hose inside diameters of 6,3 mm to 38 mm, inclusive, in accordance with ISO 4397.

NOTE 1 Materials other than carbon steel can be supplied as agreed between the manufacturer and user.

NOTE 2 For hose fittings used in hydraulic and pneumatic braking systems on road vehicles (as defined in the scope of ISO/TC 22, *Road vehicles*), see ISO 4038, ISO 4039-1 and ISO 4039-2.

These hose fittings (see Figure 1 for a typical example) are for use in hydraulic fluid power systems with hose that meets the requirements of the respective hose standards and in general applications with suitable hose.

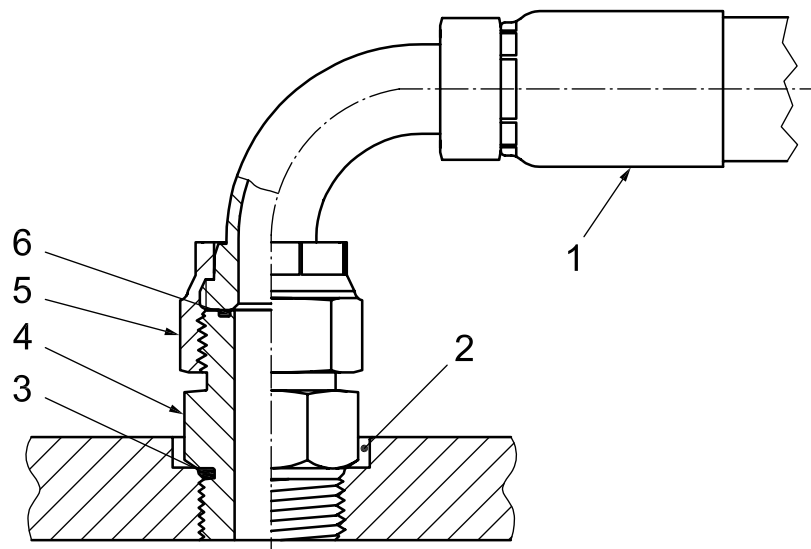

Key

- | | | | |
|---|------------------------------------|---|---------------------------------------|
| 1 | hose fitting | 4 | adapter in accordance with ISO 8434-3 |
| 2 | port in accordance with ISO 6149-1 | 5 | nut |
| 3 | O-ring seal | 6 | O-ring seal |

Figure 1 — Typical example of a hose-fitting connection with O-ring face seal end

2 Normative references

The following referenced documents are indispensable for the application of this document. For dated references, only the edition cited applies. For undated references, the latest edition of the referenced document (including any amendments) applies.

ISO 68-2, *ISO general-purpose screw threads — Basic profile — Part 2: Inch screw threads*

ISO 263, *ISO inch screw threads — General plan and selection for screws, bolts and nuts — Diameter range 0,06 to 6 in*

ISO 4397, *Fluid power systems and components — Connectors and associated components — Nominal outside diameters of tubes and nominal hose sizes*

ISO 4759-1:2000, *Tolerances for fasteners — Part 1: Bolts, screws, studs and nuts — Product grades A, B and C*

ISO 5598, *Fluid power systems and components — Vocabulary*

ISO 5864:1993, *ISO inch screw threads — Allowances and tolerances*

ISO 6149-1, *Connections for hydraulic fluid power and general use — Ports and stud ends with ISO 261 metric threads and O-ring sealing — Part 1: Ports with truncated housing for O-ring seal*

ISO 6605, *Hydraulic fluid power — Hoses and hose assemblies — Test methods*

ISO 8434-3:2005, *Metallic tube connections for fluid power and general use — Part 3: O-ring face seal connectors*

ISO 9227, *Corrosion tests in artificial atmospheres — Salt spray tests*

ISO 19879, *Metallic tube connections for fluid power and general use — Test methods for hydraulic fluid power connections*

3 Terms and definitions

For the purposes of this document, the terms and definitions given in ISO 5598 apply.

4 Performance requirements

4.1 Hose assemblies shall meet the performance requirements specified in the appropriate hose specification without leakage or failure.

4.2 The working pressure of the hose assembly shall be the lower of the pressures given for its size in ISO 8434-3 and in the relevant hose specification.

4.3 The hose-fitting portion of a hose assembly shall be tested in accordance with ISO 19879, and the complete hose assembly shall be tested in accordance with ISO 6605.

5 Designation of hose fittings

5.1 Hose fittings shall be designated by an alphanumeric code to facilitate ordering. They shall be designated by ISO 12151-1, followed by a spaced hyphen, then the connection end type, shape and style letter symbols (see 5.4), followed by another spaced hyphen, the O-ring face seal end size (nominal tube outside diameter in accordance with ISO 8434-3) and the hose size (nominal hose inside diameter in accordance with ISO 4397), each separated by a multiplication symbol (\times).

EXAMPLE A swivel hose fitting with a 45° medium elbow, for 12 mm OD tubing and 12,5 mm nominal ID hose is designated as follows:

ISO 12151-1 - SWE45M - 12 \times 12,5

5.2 The letter symbol designation of the hose fitting shall consist of the connection end type, immediately followed by the shape of the fitting and the nut style, where applicable.

5.3 Tube ends are assumed to be male and thus it is not necessary to include them in the code. However, if another end is involved, it shall be designated.

5.4 The letter symbols as given in Table 1 shall be used.

Table 1 — Letter symbols used in the designation of hose fittings

Connection end type		Symbol
Swivel	—	SW
Shape	Straight	S
	90° elbow, short	ES
	90° elbow, medium	EM
	90° elbow, long	EL
	45° elbow, short	E45S
	45° elbow, medium	E45M
Nut sealing surface	Sealing surface not exposed	A
	Sealing surface exposed	B

6 Design

6.1 Hose fitting dimensions shown in Figures 2 to 5 shall conform to those given in Tables 2 to 5 and to the relevant dimensions in ISO 8434-3.

6.2 Hexagonal tolerances across flats shall be in accordance with ISO 4759-1:2000, product grade C. Minimum across-corner hexagonal dimensions are 1,092 times the nominal width across flats. The minimum side flat is 0,43 times the nominal width across flats.

6.3 Angular tolerances on axes of ends of elbows shall be $\pm 3^\circ$ for all sizes.

6.4 Details of contour shall be as chosen by the manufacturer, provided that the dimensions given in Tables 2 to 5 are maintained.

6.5 The screw threads on the connection ends of the hose fittings shall be ISO inch screw threads in accordance with ISO 263 and ISO 8434-3:2005, Annex A, except for 1-14 UNS classes 2A and 2B threads, whose dimensions are also found in ISO 8434-3:2005, Annex A.

7 Manufacture

7.1 Construction

Hose fittings may be made by forging or cold forming, machined from barstock or manufactured from multiple components.

7.2 Workmanship

Workmanship shall conform to the best commercial practice to produce high-quality hose fittings. Hose fittings shall be free from visual contaminants, all hanging burrs, loose scale and slivers that can be dislodged in use, and any other defects that can affect the functioning of the parts. All machined surfaces shall have a surface roughness value of $Ra \leq 6,3 \mu\text{m}$, except where otherwise specified.

7.3 Finish

The external surface and threads of all carbon steel parts shall be plated or coated with a suitable material that passes a 72 h neutral salt-spray test in accordance with ISO 9227, unless otherwise agreed upon by the manufacturer and the user. Any appearance of red rust during the salt-spray test on any area, except those noted below, shall be considered failure:

- all internal fluid passages;
- edges, such as hex points, serrations and crests of threads, where there can be mechanical deformation of the plating or coating typical of mass-produced parts or shipping effects;
- areas where there is mechanical deformation of the plating or coating caused by crimping, flaring, bending and other post-plate metal-forming operations;
- areas where the parts are suspended or affixed in the test chamber where condensate can accumulate.

Internal fluid passages shall be protected from corrosion during storage.

NOTE Cadmium plating is deprecated due to environmental concerns. Changes in plating can affect assembly torques and require requalification, when applicable.

7.4 Fitting protection

By a method agreed between the supplier and purchaser, the face of the hose fittings and threads (both internal and external) shall be protected by the manufacturer from nicks and scratches that can be detrimental to the functioning of the hose fitting. Passages shall be securely covered to prevent the entrance of dirt or other contaminants.

8 Assembly instructions

The assembly of the hose fittings to other connectors or tubes shall be carried out without external loads. The manufacturer shall draw up assembly instructions for the use of hose fittings. These instructions shall include at least the following:

- instructions regarding the assembly of the hose fitting, such as the number of wrenching turns or assembly torque;
- recommendations regarding the tools to be used for assembly.

When hose fittings are used with tubes, follow the instructions related to material, preparation and attachment given in ISO 8434-3, as appropriate.

9 Procurement information

The following minimum information should be supplied by the purchaser when making an inquiry or placing an order:

- description of hose fitting using designation in accordance with Clause 5;
- material of hose fitting if other than carbon steel;
- hose type and size;
- fluid being conveyed;
- working pressure;
- working temperature (ambient and of the fluid).

10 Marking

Hose fittings shall be permanently marked with the manufacturer's name or trademark.

11 Identification statement (reference to this part of ISO 12151)

It is strongly recommended to manufacturers who have chosen to conform to this part of ISO 12151 that the following statement be used in test reports, catalogues and sales literature:

"Hose fittings with O-ring face seal ends conform to ISO 12151-1, Connections for hydraulic fluid power and general use — Hose fittings — Part 1: Hose fittings with ISO 8434-3 O-ring face seal ends."

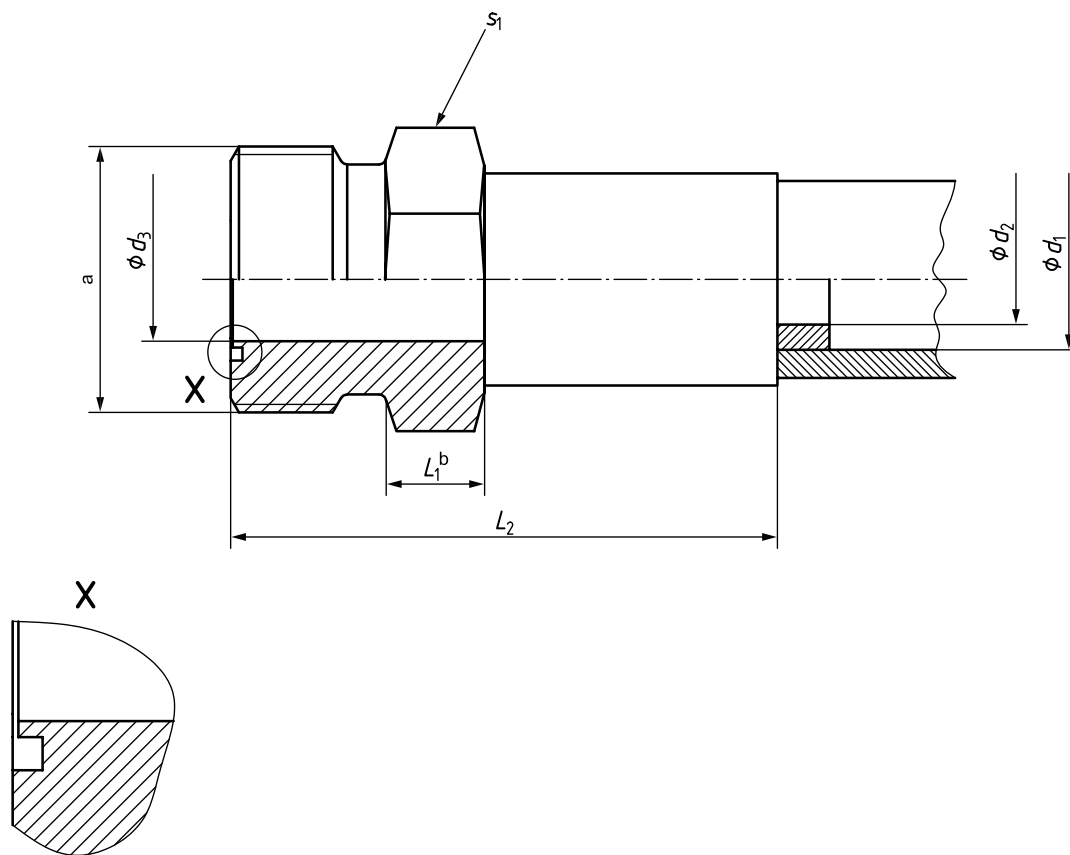

NOTE 1 Connection details and O-rings in accordance with ISO 8434-3.

NOTE 2 Method of attachment of hose fitting to hose is optional.

a Thread.

b Width across flats.

Figure 2 — Male hose fitting, straight (S)

.....

Table 2 — Dimensions of male hose fittings, straight (S)

Dimensions in millimetres

Hose fitting size	Thread ^a	Nominal connection size	Nominal hose size d_1	d_2^b	d_3^c	L_1	L_2^d	s_1^e
				min.	max.	min.	max.	
6 × 6,3	9/16-18 UNF	6	6,3	3	5,2	10	60	17
6 × 8	9/16-18 UNF	6	8	5	5,2	10	65	17
10 × 6,3	11/16-16 UNF	10	6,3	3	6,7	10	63	19
10 × 8	11/16-16 UNF	10	8	5	6,7	10	67	19
10 × 10	11/16-16 UNF	10	10	6	6,7	10	70	19
12 × 10	13/16-16 UN	12	10	6	9,7	11	73	22
12 × 12,5	13/16-16 UN	12	12,5	8	9,7	11	80	22
16 × 12,5	1-14 UNS	16	12,5	8	12,8	13	85	27
16 × 16	1-14 UNS	16	16	11	12,8	13	90	27
20 × 16	1 3/16-12 UN	20	16	11	15,8	15	94	32
20 × 19	1 3/16-12 UN	20	19	14	15,8	15	95	32
25 × 19	1 7/16-12 UN	25	19	14	20,8	19	100	41
25 × 25	1 7/16-12 UN	25	25	19	20,8	19	100	41
30 × 25	1 11/16-12 UN	30	25	19	26,3	21	108	46
30 × 31,5	1 11/16-12 UN	30	31,5	25	26,3	21	120	46
38 × 31,5	2-12 UN	38	31,5	25	32,4	25	132	55
38 × 38	2-12 UN	38	38	31	32,4	25	150	55

^a In accordance with ISO 68-2, ISO 263 and ISO 5864:1993, class 2A (except for 1-14 UNS-2A thread, the dimensions of which are given in ISO 8434-3:2005, Annex A).

^b Minimum diameter at any point through the hose fitting prior to assembly to the hose. The diameter after assembly to the hose shall not be less than $0,9d_2$.

^c Dimensions d_3 are in accordance with ISO 8434-3, except that the minimum diameter for d_3 shall not be less than d_2 . Transition between diameters d_2 (hose nipple through diameter) and d_3 (through diameter of the face seal end) shall be located to minimize stress concentration.

^d Dimension L_2 is measured after assembly.

^e In accordance with ISO 4759-1:2000, product grade C, and ISO 8434-3:2005.

Dimensions in millimetres

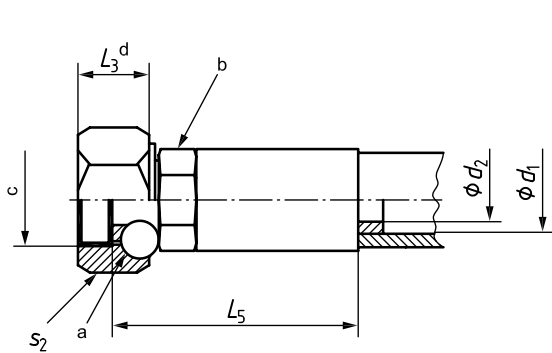

a) Style A

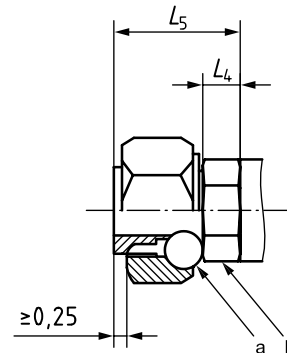

b) Style B
(shown with sealing surface exposed)

NOTE 1 Connection details in accordance with ISO 8434-3 for NA or NB nut and WDNP nipple.

NOTE 2 Method of attachment of hose fitting to hose is optional.

- a Method of attachment of swivel nut is as chosen by the manufacturer.
- b Hexagonal head required, but its size is optional.
- c Thread.
- d Width across flats.

Figure 3 — Female swivel hose fitting, straight — Styles A (SWSA) and B (WSB)

.....

Table 3 — Dimensions of female swivel hose fittings, straight (SWSA and SWSB)

Dimensions in millimetres

Hose fitting size	Thread ^a	Nominal connection size	Nominal hose size d_1	d_2^b min.	L_3^c min.	L_4 min.	L_5^d max.		s_2^e
							SWSA	SWSB	
6 × 6,3	9/16-18 UNF	6	6,3	3	6,5	6	70	80	17
6 × 8	9/16-18 UNF	6	8	5	6,5	6	75	85	17
10 × 6,3	11/16-16 UNF	10	6,3	3	6,5	6	73	83	22
10 × 8	11/16-16 UNF	10	8	5	6,5	6	78	88	22
10 × 10	11/16-16 UNF	10	10	6	6,5	6	80	90	22
12 × 10	13/16-16 UN	12	10	6	8	6	85	95	24
12 × 12,5	13/16-16 UN	12	12,5	8	8	6	90	100	24
16 × 12,5	1-14 UNS	16	12,5	8	9,5	6	93	108	30
16 × 16	1-14 UNS	16	16	11	9,5	6	95	110	30
20 × 16	1 3/16-12 UN	20	16	11	9,5	6	100	115	36
20 × 19	1 3/16-12 UN	20	19	14	9,5	7	100	115	36
25 × 19	1 7/16-12 UN	25	19	14	11	7	105	120	41
25 × 25	1 7/16-12 UN	25	25	19	11	8	105	120	41
30 × 25	1 11/16-12 UN	30	25	19	12,5	8	115	130	50
30 × 31,5	1 11/16-12 UN	30	31,5	25	12,5	9	125	140	50
38 × 31,5	2-12 UN	38	31,5	25	15,5	9	135	155	60
38 × 38	2-12 UN	38	38	31	15,5	9	150	170	60

^a In accordance with ISO 68-2, ISO 263 and ISO 5864:1993, class 2B (except for 1-14 UNS-2B thread, the dimensions of which are given in ISO 8434-3:2005, Annex A).

^b Minimum diameter at any point through the hose fitting prior to assembly to the hose. The diameter after assembly to the hose shall not be less than $0,9d_2$.

^c Crimp style nut is permissible, but width of hexagonal head shall meet L_3 min.

^d Dimension L_5 is measured after assembly.

^e In accordance with ISO 4759-1:2000, product grade C, and ISO 8434-3:2005.

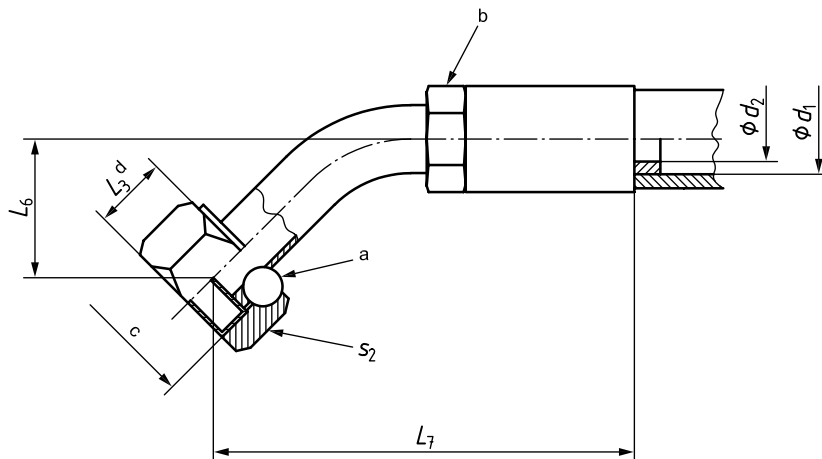

NOTE 1 Connection details in accordance with ISO 8434-3 for NA or NB nut and WDNP nipple.

NOTE 2 Method of attachment of hose fitting to hose is optional.

- a Method of attachment of swivel nut is as chosen by the manufacturer.
- b Hexagonal head optional.
- c Thread.
- d Width across flats.

**Figure 4 — Female swivel hose fitting —
45° elbow [short (SWE45S) and medium (SWE45M)]**

**Table 4 — Dimensions of female swivel hose fitting —
45° elbow (SWE45S and SWE45M)**

Dimensions in millimetres

Hose fitting size	Thread ^a	Nominal connection size	Nominal hose size d_1	d_2^b min.	L_3^c min.	L_6^d $\pm 1,5$		L_7^e max.		s_2^f
						SWE45S	SWE45M	SWE45S	SWE45M	
6 × 6,3	9/16-18 UNF	6	6,3	3	6,5	10	—	90	—	17
6 × 8	9/16-18 UNF	6	8	5	6,5	10	—	95	—	17
10 × 6,3	11/16-16 UNF	10	6,3	3	6,5	11	—	93	—	22
10 × 8	11/16-16 UNF	10	8	5	6,5	11	—	98	—	22
10 × 10	11/16-16 UNF	10	10	6	6,5	11	—	100	—	22
12 × 10	13/16-16 UN	12	10	6	8	15	—	105	—	24
12 × 12,5	13/16-16 UN	12	12,5	8	8	15	—	110	—	24
16 × 12,5	1-14 UNS	16	12,5	8	9,5	16	—	118	—	30
16 × 16	1-14 UNS	16	16	11	9,5	16	—	120	—	30
20 × 16	1 3/16-12 UN	20	16	11	9,5	21	—	124	—	36
20 × 19	1 3/16-12 UN	20	19	14	9,5	21	—	125	—	36
25 × 19	1 7/16-12 UN	25	19	14	11	24	—	130	—	41
25 × 25	1 7/16-12 UN	25	25	19	11	24	—	130	—	41
30 × 25	1 11/16-12 UN	30	25	19	12,5	25	32	160	167	50
30 × 31,5	1 11/16-12 UN	30	31,5	25	12,5	25	32	170	177	50
38 × 31,5	2-12 UN	38	31,5	25	15,5	27	42	175	190	60
38 × 38	2-12 UN	38	38	31	15,5	27	42	190	205	60

^a In accordance with ISO 68-2, ISO 263 and ISO 5864:1993, class 2B (except for 1-14 UNS-2B thread, the dimensions of which are given in ISO 8434-3:2005, Annex A).

^b Minimum diameter at any point through the hose fitting prior to assembly to the hose. The diameter after bending or assembly to the hose shall not be less than 0,9 d_2 .

^c Crimp style nut is permissible, but width of hexagonal head shall meet L_3 min.

^d Short-drop (SWE45S) hose fittings may not be manufactured by preferred methods with ratings suitable for use with high pressure spiral wire hose, which is typically used at working pressures of 28 MPa (280 bar), 21 MPa (210 bar) or 17,5 MPa (175 bar) and higher in hose sizes 25, 31,5 and 38, respectively. Use preferred medium-drop (SWE45M) hose fittings or consult manufacturer for availability.

^e Dimension L_7 is measured after assembly.

^f In accordance with ISO 4759-1:2000, product grade C, and ISO 8434-3:2005.

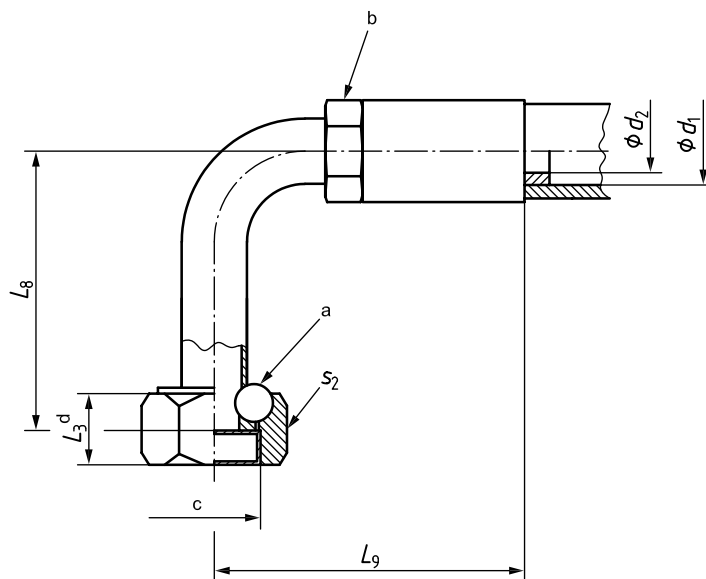

NOTE 1 Connection details in accordance with ISO 8434-3 for NA or NB nut and WDNP nipple.

NOTE 2 Method of attachment of hose fitting to hose is optional.

- a Method of attachment to swivel nut is as chosen by the manufacturer.
- b Hexagonal head optional.
- c Thread.
- d Width across flats.

**Figure 5 — Female swivel hose fitting —
90° elbow [short (SWES), medium (SWEM), long (SWEL)]**

**Table 5 — Dimensions of female swivel hose fittings —
90° elbow (SWES, SWEM, SWEL)**

Dimensions in millimetres

Hose fitting size	Thread ^a	Nominal connection size	Nominal hose size d_1	d_2^b min.	L_3^c min.	L_8^d ± 1,5			L_9^h max.	s_2^i
						SWES ^e	SWEM ^f	SWEL ^g		
6 × 6,3	9/16-18 UNF	6	6,3	3	6,5	21	32	46	90	17
6 × 8	9/16-18 UNF	6	8	5	6,5	21	32	46	95	17
10 × 6,3	11/16-16 UNF	10	6,3	3	6,5	23	38	54	93	22
10 × 8	11/16-16 UNF	10	8	5	6,5	23	38	54	98	22
10 × 10	11/16-16 UNF	10	10	6	6,5	23	38	54	100	22
12 × 10	13/16-16 UN	12	10	6	8	29	41	64	105	24
12 × 12,5	13/16-16 UN	12	12,5	8	8	29	41	64	110	24
16 × 12,5	1-14 UNS	16	12,5	8	9,5	32	47	70	118	30
16 × 16	1-14 UNS	16	16	11	9,5	32	47	70	120	30
20 × 16	1 3/16-12 UN	20	16	11	9,5	48	58	96	124	36
20 × 19	1 3/16-12 UN	20	19	14	9,5	48	58	96	125	36
25 × 19	1 7/16-12 UN	25	19	14	11	56	71	114	130	41
25 × 25	1 7/16-12 UN	25	25	19	11	56	71	114	130	41
30 × 25	1 11/16-12 UN	30	25	19	12,5	64	78	129	160	50
30 × 31,5	1 11/16-12 UN	30	31,5	25	12,5	64	78	129	170	50
38 × 31,5	2-12 UN	30	31,5	25	15,5	69	86	141	175	60
38 × 38	2-12 UN	38	38	31	15,5	69	86	141	190	60

^a In accordance with ISO 68-2, ISO 263 and ISO 5864:1993, class 2B (except for 1-14 UNS-2B thread, the dimensions of which are given in ISO 8434-3:2005, Annex A).

^b Minimum diameter at any point through the hose fitting prior to assembly to the hose. The diameter after bending or assembly to the hose shall not be less than 0,9 d_2 .

^c Crimp style nut is permissible, but width of hexagonal head shall meet L_3 min.

^d Short-drop (SWES) hose fittings may not be manufactured by preferred methods with ratings suitable for use with high-pressure spiral wire hose, which is typically used at working pressures of 28 MPa (280 bar), 21 MPa (210 bar) or 17,5 MPa (175 bar) and higher in hose sizes 25, 31,5 and 38, respectively. Use preferred medium-drop (SWEM) hose fittings or consult manufacturer for availability.

^e Short-drop (SWES) dimensions. See Annex A.

^f Medium-drop (SWEM) dimensions. Medium-drop hose fittings clear 90° adjustable stud elbow (SDE) in accordance with ISO 8434-3:2005. See Annex A.

^g Long-drop (SWEL) dimensions. Long-drop hose fittings clear short-drop (SWES) hose fittings. See Annex A.

^h Dimension L_9 is measured after assembly.

ⁱ In accordance with ISO 4759-1:2000, product grade C, and ISO 8434-3:2005.

Annex A (informative)

Illustrations of applications for short, medium and long ISO 12151-1 hose fittings

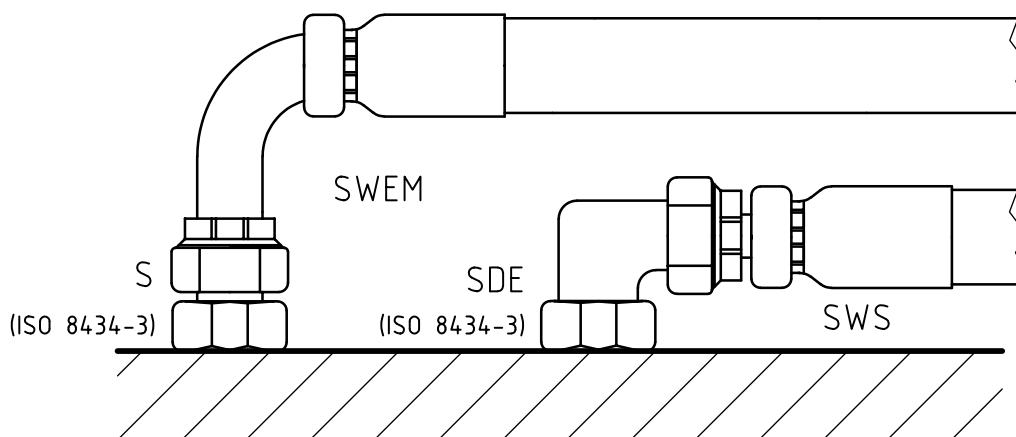
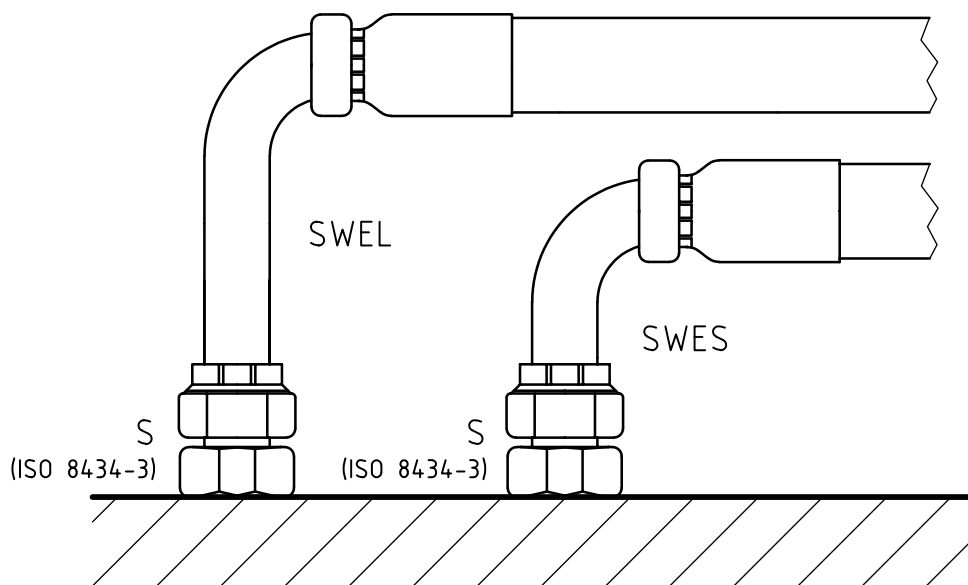

www.iso.org

Bibliography

- [1] ISO 1436, *Rubber hoses and hose assemblies — Wire-braid-reinforced hydraulic types for oil-based or water-based fluids — Specification*
- [2] ISO 3862, *Rubber hoses and hose assemblies — Rubber-covered spiral-wire-reinforced hydraulic types for oil-based or water-based fluids — Specification*
- [3] ISO 3949, *Plastics hoses and hose assemblies — Textile-reinforced types for hydraulic applications — Specification*
- [4] ISO 4038, *Road vehicles — Hydraulic braking systems — Simple flare pipes, tapped holes, male fittings and hose end fittings*
- [5] ISO 4039-1, *Road vehicles — Pneumatic braking systems — Part 1: Pipes, male fittings and tapped holes with facial sealing surface*
- [6] ISO 4039-2, *Road vehicles — Pneumatic braking systems — Part 2: Pipes, male fittings and holes with conical sealing surface*
- [7] ISO 4079, *Rubber hoses and hose assemblies — Textile-reinforced hydraulic types for oil-based or water-based fluids — Specification*

ICS 23.040.70; 23.100.40

Price based on 15 pages