**Agricultural machinery — Agricultural
trailers and trailed equipment —
Drawbar jacks**

*Matériel agricole — Remorques agricoles et matériel traîné —
Béquilles d'attelage*



Reference number
ISO 12140:2013(E)

© ISO 2013



COPYRIGHT PROTECTED DOCUMENT

© ISO 2013

All rights reserved. Unless otherwise specified, no part of this publication may be reproduced or utilized otherwise in any form or by any means, electronic or mechanical, including photocopying, or posting on the internet or an intranet, without prior written permission. Permission can be requested from either ISO at the address below or ISO's member body in the country of the requester.

ISO copyright office
Case postale 56 • CH-1211 Geneva 20
Tel. + 41 22 749 01 11
Fax + 41 22 749 09 47
E-mail copyright@iso.org
Web www.iso.org

Published in Switzerland

Contents

Page

Foreword	iv
1 Scope	1
2 Normative references	1
3 Terms and definitions	1
4 Requirements	4
4.1 Crank effort.....	4
4.2 Overtravel.....	4
4.3 Ground pressure.....	4
4.4 Corrosion protection.....	4
4.5 Service life.....	4
4.6 Rated static compressive load capacity.....	4
4.7 Rated dynamic compressive load capacity.....	4
4.8 Rated static tensile load capacity.....	4
4.9 Rated dynamic tensile load capacity.....	5
4.10 Rated static side load capacity.....	5
4.11 Rated static side torque class.....	5
4.12 Crank assembly.....	5
4.13 Prevention of ground contact when not in use.....	5
4.14 Security in operating position.....	6
4.15 Hydraulic components and fittings.....	6
4.16 Application performance.....	6
5 Marking	7
6 Acceptance tests — Installation and procedures	8
6.1 General procedures and installation of jack.....	8
6.2 Jack stand system design verification tests.....	8
6.3 Jack stand system application tests.....	9
7 Information for use	10
Bibliography	11

Foreword

ISO (the International Organization for Standardization) is a worldwide federation of national standards bodies (ISO member bodies). The work of preparing International Standards is normally carried out through ISO technical committees. Each member body interested in a subject for which a technical committee has been established has the right to be represented on that committee. International organizations, governmental and non-governmental, in liaison with ISO, also take part in the work. ISO collaborates closely with the International Electrotechnical Commission (IEC) on all matters of electrotechnical standardization.

The procedures used to develop this document and those intended for its further maintenance are described in the ISO/IEC Directives, Part 1. In particular the different approval criteria needed for the different types of ISO documents should be noted. This document was drafted in accordance with the editorial rules of the ISO/IEC Directives, Part 2. www.iso.org/directives

Attention is drawn to the possibility that some of the elements of this document may be the subject of patent rights. ISO shall not be held responsible for identifying any or all such patent rights. Details of any patent rights identified during the development of the document will be in the Introduction and/or on the ISO list of patent declarations received. www.iso.org/patents

Any trade name used in this document is information given for the convenience of users and does not constitute an endorsement.

The committee responsible for this document is ISO/TC 23, *Tractors and machinery for agriculture and forestry*, Subcommittee SC 3, *Safety and comfort*.

This second edition cancels and replaces the first edition (ISO 12140:1998), which has been technically revised.

.....

Agricultural machinery — Agricultural trailers and trailed equipment — Drawbar jacks

1 Scope

This International Standard specifies terms and definitions, establishes test procedures, and creates minimum performance requirements for telescopic mechanical screw-type jacks or hydraulic jacks mounted on agricultural implements as original equipment and/or replacement jacks.

Furthermore, this International Standard defines terms, establishes test procedures, and creates minimum acceptance criteria for the use of telescopic mechanical screw-type jacks or hydraulic jacks mounted on agricultural implements as original equipment jacks or jacks fitted with a jack attachment mounts (both weld-on and removable). In addition, it specifies minimum markings and information for use to be provided by the jack manufacturer.

These jacks are used specifically for:

- supporting the hitch points of towed agricultural implements during storage;
- lifting and lowering of implement hitches to facilitate attaching to or disconnecting from an agricultural tractor or other agricultural machines;
- levelling of machinery for stationary use.

NOTE Drawbar jacks as part/component of a machine are also covered by ISO 4254-1:2013.

2 Normative references

The following documents, in whole or in part, are normatively referenced in this document and are indispensable for its application. For dated references, only the edition cited applies. For undated references, the latest edition of the referenced document (including any amendments) applies.

ISO 4413, *Hydraulic fluid power — General rules and safety requirements for systems and their components*

ISO 9227, *Corrosion tests in artificial atmospheres — Salt spray tests*

3 Terms and definitions

For the purposes of this document, the following terms and definitions apply.

3.1 jack

hand or power-operated mechanism, with a ground contact pad (base) or wheel and fixing point (jack mount or mounting point), designed for controlled vertical movement

Note 1 to entry: A hand-operated jack typically uses mechanical means to control movement. A powered-operated jack typically uses hydraulic fluid displacement to control movement.

3.2

towed agricultural implement

machine or device that is designed to perform agricultural field operations and is pulled by an agricultural tractor or other agricultural machine and is usually equipped with wheels required for transport

3.3

static compressive load

vertical force measured at the jack location under static conditions

3.4

dynamic compressive load

vertical force measured at the jack location during jack extension (lifting)

3.5

static tensile load

force opposite of static compressive load resulting in a tension load applied to the jack

3.6

dynamic tensile load

force opposite of dynamic compressive load resulting in a tension load applied to the jack

3.7

side load

<fore-aft> force applied in a plane perpendicular to the longitudinal axis of the jack in a direction generally aligning with the towing direction of the towed agricultural implement

3.8

side load

<lateral> force applied in a plane perpendicular to the longitudinal axis of the jack at right angles to the general towing direction of the towed agricultural implement

3.9

screw and nut

threaded portion of the jack that transforms rotational motion of the crank assembly into linear motion of the jack

3.10

screw travel

total change in length of the jack from a fully retracted to a fully extended condition caused by screw movement only

3.11

swivel mount

jack mounting method that allows the jack to be rotated to a storage position without removing the jack from the towed implement

3.12

crank assembly

portion of the jack consisting of a crank and knob used to actuate the screw to extend or retract the jack

3.13

side wind jack

assembly of crank, knob, outer tube, inner tube and screw/nut that causes the extension or retraction of the jack when the crank assembly is rotated about an axis perpendicular to the screw travel

3.14

top wind jack

assembly of crank, knob, outer tube, inner tube and screw/nut that causes the extension or retraction of the jack when the crank assembly is rotated about an axis of rotation parallel to the screw travel

3.15

base

bottom load-bearing portion of the inner tube that transmits force to the ground or floor

3.16**jack cycle**

cycle consisting of extending the jack through 65 % of the jack screw travel and then retracting the jack back to its original length

Note 1 to entry: If a particular jack has added screw travel for the purpose of greater unloaded range, the jack cycle can be based on 65 % of the normal screw travel.

3.17**retracted length**

minimum attainable dimension from the centre of the mount to the bottom of the base of the jack

Note 1 to entry: In the case where the jack mount is not part of the jack during manufacture, use the uppermost part of the outer tube as the upper measuring point.

3.18**extended length**

maximum attainable dimension from the centre of the mount to the bottom of the base of the jack

Note 1 to entry: In the case when the jack mount is not part of the jack during manufacturing, use the uppermost part of the jack outer tube as the upper measuring point.

3.19**basic rated life**

L_{10}

term taken from bearing terminology, indicating that the 90 %-reliable life of the samples tested pass a given requirement

3.20**crank effort**

tangential force, measured at the crank knob position, required to actuate the jack

3.21**jack stand system**

includes the jack, attaching structure of the towed implement, jack mount, and attached components

3.22**implement tongue**

that portion of the machine designed to be attached to the drawbar or hitch of the towing machine

3.23**drawbar**

mechanical connection mounted on the rear of an agricultural tractor or other agricultural machine for the mechanical coupling of an implement

3.24**towed implement mount**

part of the implement tongue designed to mount or accept the jack

3.25**largest application vertical static load**

static compressive load when the intended application is at the maximum rated weight configuration

3.26**normal operational length**

jack extended to its application length to properly support and lift the implement tongue to the appropriate height for hitching to the towing machine

Note 1 to entry: If the application length is unknown, the operational length shall be the maximum extended length of the jack.

4 Requirements

4.1 Crank effort

During the jack cycle, the crank effort shall not exceed 225 N while the jack is loaded to its rated dynamic compressive load capacity or, if applicable, its rated dynamic tensile load capacity. The knob on the crank assembly shall be designed to rotate freely on the crank and the knob shall have a radial dimension of not less than 25 mm.

4.2 Overtravel

The jack shall be designed with sufficient means to withstand the applied force when attempting to extend or retract beyond the intended screw travel. Without functional or catastrophic failures, the jack shall be able to sustain one and one half times the maximum crank effort experienced at the rated dynamic compressive lift capacity or, if applicable, the rated dynamic tensile load capacity.

4.3 Ground pressure

If the jack is provided with a substantially flat base, the base shall be of sufficient size that the average ground pressure shall not exceed 400 kPa. The implement manufacturer may include or recommend additional support to meet the required value. Jacks equipped with a wheel or other base configuration intended for use on an improved or special surface are excluded from this requirement.

4.4 Corrosion protection

The jack shall not experience a functional failure after a 48-h salt spray exposure in accordance with ISO 9227.

Note Guidance can be drawn from ASTM B-117-09 also.

4.5 Service life

The service life for the jack shall be greater than 250 jack cycles when tested in accordance with this International Standard.

4.6 Rated static compressive load capacity

The rated static compressive load capacity shall not exceed one half that of the static compressive load sufficient to cause catastrophic failure. This load shall be applied through the intended jack mount or swivel mount. The jack shall also be able to support the rated static compressive load and afterward meet all other requirements of this International Standard. This is a maximum value and may be reduced by the jack or implement manufacturer based on application.

4.7 Rated dynamic compressive load capacity

The rated dynamic compressive load capacity shall not exceed the largest dynamic compressive load to be moved by the jack through a jack cycle, and shall meet the service life and crank effort requirements of this International Standard. This load shall be applied through the intended jack mount or swivel mount. The jack shall also independently meet all other requirements of this International Standard. The rated dynamic compressive load capacity shall not exceed the rated static compressive load capacity. This is a maximum value and may be reduced by the jack or implement manufacturer based on application.

4.8 Rated static tensile load capacity

The rated static tensile load capacity shall not exceed one half that of the static tensile load sufficient to cause catastrophic failure. This load shall be applied through the intended jack mount or swivel mount. The jack shall also be able to support the rated static tensile load and afterward meet all other

requirements of this International Standard. This is a maximum value and may be reduced by the jack or implement manufacturer based on application.

4.9 Rated dynamic tensile load capacity

The rated dynamic tensile load capacity shall not exceed the largest dynamic tensile load to be repeatedly retracted (pulled) by the jack, and shall meet the service life and crank effort requirements of this International Standard. This load shall be applied through the intended jack mount or swivel mount. The jack shall also independently meet all other requirements of this International Standard. The rated dynamic tensile load capacity shall not exceed the rated static tensile load capacity. This is a maximum value and may be reduced by the jack or implement manufacturer based on application.

4.10 Rated static side load capacity

The rated static side load capacity shall not exceed one-half that of the static side load sufficient to cause catastrophic failure. This load shall be applied through the intended jack mount or swivel mount. The jack shall also be able to support the rated static side load and afterward meet all other requirements of this International Standard. The rated static side load capacity is the least value resulting from loading in any direction, such as fore-aft, lateral or other. This is a maximum value and may be reduced by the jack or implement manufacturer based on application.

4.11 Rated static side torque class

Jacks that have been manufactured with a specific mount or mounting location shall be classified in accordance with [Table 1](#).

The rated static side torque shall be calculated as follows: rated static side torque is equal to rated static side load times the distance from the jack mounting location to the bottom of the base at maximum extension.

Table 1 — Rated static side torque classes

Class	Torque, in Newton metres Nm
I	<1351
II	1 351 to 2 050
III	2 051 to 2 700
IV	2 701 to 3 400
V	3 401 to 4 100
VI	4 101 to 5 400
VII	>5 400

4.12 Crank assembly

If the design of a mechanical jack includes a crank assembly for controlling the height adjustment of the drawbar, it shall be possible to stow the handle to avoid impalement.

4.13 Prevention of ground contact when not in use

The jack shall be either so designed, or have such a device installed, that it can be prevented from winding or dropping down by its own volition while the towed agricultural equipment or trailed equipment is in motion over the ground.

4.14 Security in operating position

For jacks that can be folded or moved into a storage position when not in use, it shall be possible to locate them securely in the operating position. The jack shall be lockable (by design or additional means). Supporting or height adjusting of the drawbar shall not be possible unless the jack is locked. This requirement shall be verified during the test described in [4.16.2](#).

For hydraulic jacks, a means to ensure that the load is maintained and the jack does not drift down shall be affixed to the jack, e.g. a holding valve. This requirement shall be verified during the test described in [6.3.3](#).

4.15 Hydraulic components and fittings

Hydraulic systems for hydraulic jacks shall comply with the safety requirements of ISO 4413.

4.16 Application performance

4.16.1 General

These performance requirements apply when the jack is mounted to the implement in the manner and location dictated by the implement design. Performance requirements shall be verified either by analytical methods or by successful performance of the tests described in [Clause 6](#).

4.16.2 Static application vertical load

The jack stand system shall be capable of withstanding a static vertical load equal to 200 % of the largest application vertical static load. There shall be no functional or catastrophic failure of the jack stand system.

4.16.3 Static application side load

The jack stand system shall be capable of withstanding a vertical load of 120 % of largest application vertical static load while applying a side load of 50 % of the largest application vertical static load to the jack. There shall be no functional or catastrophic failure of the jack stand system.

4.16.4 Functional failure

The jack or jack stand system is described as having a functional failure if the jack does not meet any one of the following conditions:

- a) have the ability to complete 10 jack cycles at the rated dynamic compressive load capacity;
- b) have the ability to complete 10 jack cycles at the rated dynamic tensile load capacity, if applicable;
- c) in the case of a swivel mount, the jack shall be able to rotate;
- d) have the ability to sustain the rated static side load capacity.

4.16.5 Catastrophic failure

The jack or jack stand system is described as having a catastrophic failure if the jack does not meet any one of the following conditions:

- a) have the ability to support its rated static compressive load capacity at any position in the jack travel;
- b) have the ability to sustain its rated static tensile load capacity at any position in the jack travel, if applicable;
- c) have the ability to withstand the static application side load at any position in the jack travel.

5 Marking

The permanent marking on a jack shall take into account changes in environment and use to sustain little or no change in physical properties. Examples of marking processes include stamping, embossing, permanent single-use adhesive labels or mechanically fastened nameplates.

Each jack shall be permanently marked:

- a) to indicate its rated dynamic and static compressive load capacities or based on application, to indicate the rated static tensile load capacity and rated dynamic tensile load capacity in place of the respective compressive load capacity values;
- b) with a jack manufacturer's identification and a serial number or code indicating lot or approximate date of manufacture;
- c) in the case of a hydraulic jack, the fluid to be used and an indication that it is essential that only a recommended fluid be used;
- d) with a static side torque class in accordance with [Table 1](#) for jacks with a specific mount or mounting location.

NOTE Concise common industry terms or abbreviated terms can be used in place of the above-mentioned terms.

If the jack stand system has an adjustable mount, an appropriate instruction sign shall be affixed to the implement near the jack mount indicating the proper adjustment of the jack or jack stand system. See [Figure 1](#) as an example.

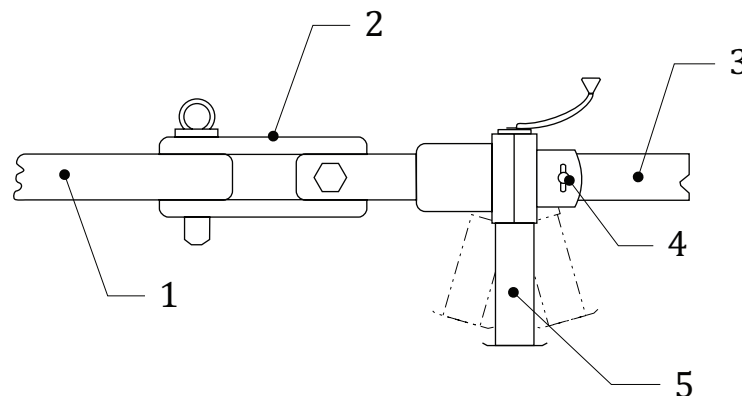

Key

- 1 drawbar
- 2 clevis
- 3 tongue
- 4 positioning nut
- 5 jack

Figure 1 — Jack stand system — Example

6 Acceptance tests — Installation and procedures

6.1 General procedures and installation of jack

- a) For all tests, the jack shall be installed in accordance with the manufacturer's instructions on an implement tongue or a simulated fixture and fitted with the same mounting hardware with which the jack would normally be mounted.
- b) All forces and restraints shall be applied in such a manner as to closely simulate actual field conditions.
- c) A new jack shall be used for each test.

NOTE 1 A break-in period of 10 jack cycles is allowed for each new jack. Thermal and environmental conditions are intended to closely resemble field or application conditions.

- d) Jack actuation shall resemble the input force in both type and direction found in actual practice. This generally consists of a force at an offset distance as determined by the crank assembly.

NOTE 2 If the intended application includes an outboard bearing, elimination of the tangential crank effort can more closely simulate field experience. Some of the tests in [Clause 6](#) are of an iterative nature. It is possible that several trial "rated loads" can be evaluated.

- e) Extend the jack to its maximum extended length.
- f) For application testing, extend the jack to its normal operational length.

6.2 Jack stand system design verification tests

6.2.1 Crank effort test

- a) Mount jack as specified in [6.1](#).
- b) Load the jack to the rated dynamic compressive load capacity or if applicable, its rated dynamic tensile load capacity.
- c) Measure the crank effort.
- d) Test results shall be verified in accordance with [4.1](#).

6.2.2 Overtravel

- a) Mount jack as specified in [6.1](#).
- b) Extend and retract the jack until all internal stops have been encountered.
- c) Test results shall be verified in accordance with [4.2](#).

6.2.3 Ground pressure

- a) Determine the projected base area.
- b) Calculate the ground pressure using the rated dynamic compressive load capacity.
- c) Test results shall be verified in accordance with [4.3](#).

6.2.4 Corrosion protection test

- a) Expose jack in its typical static position to a 48-h salt spray test in accordance with ISO 9227.
- b) Test results shall be verified in accordance with [4.4](#).

6.2.5 Rated static compressive load capacity test

- a) Mount jack as specified in [6.1](#).
- b) Extend the jack to its maximum extended length.
- c) Apply a static compressive load in increments determined by the jack manufacturer.
- d) Test results shall be verified in accordance with [4.6](#).

6.2.6 Rated dynamic compressive load capacity test

- a) Mount jack as specified in [6.1](#).
- b) Load the jack to the expected rated dynamic compressive load capacity.
- c) Complete adequate jack cycles to satisfy the service life.
- d) Test results shall be verified in accordance with [4.7](#).

6.2.7 Rated static tensile load capacity test

- a) Mount jack as specified in [6.1](#).
- b) Extend the jack to its maximum extended length.
- c) Apply a static tensile load in increments determined by the jack manufacturer.
- d) Test results shall be verified in accordance with [4.8](#).

6.2.8 Rated dynamic tensile load capacity test

- a) Mount jack as specified in [6.1](#).
- b) Load the jack to the expected rated dynamic tensile load capacity.
- c) Complete adequate jack cycles to satisfy the service life.
- d) Test results shall be verified in accordance with [4.9](#).

6.2.9 Rated static side load capacity test

- a) Mount jack as specified in [6.1](#).
- b) Extend the jack to its normal operational length and apply a side load in increments.
- c) Test results shall be verified in accordance with [4.10](#).

6.3 Jack stand system application tests

6.3.1 Maximum static application vertical load capacity test

- a) Mount jack as specified in [6.1](#).
- b) Extend the jack to its normal operational length.
- c) Apply a static load equal to 200 % of the largest application vertical static load.
- d) Test results shall be verified in accordance with [4.16.1](#).

6.3.2 Maximum static application side load capacity test

- a) Mount jack as specified in [6.1](#).
- b) Extend the jack to its normal operational length.
- c) Apply 120 % of the largest application vertical static load.
- d) With the base of the jack held against a rigid vertical step, apply a horizontal side load equal to 50 % of the largest application vertical static load. The force shall be applied in the direction deemed most likely to cause a jack stand system failure.
- e) A new jack stand system should be used for each test.
- f) Test results shall be verified in accordance with [4.16.2](#).

6.3.3 Maintenance of the load

NOTE This procedure applies to hydraulic jacks only.

- a) Attach the jack in accordance with [6.1](#).
- b) Apply a load equal to the rated load.
- c) Extend the jack to its maximum extended length and measure the vertical height of the point of application of the load.
- d) At each interval of 10 min over a period of 30 min, re-measure the vertical height.
- e) The decrease in the height of the point of application of the load after each 10-min interval shall not exceed 1 mm.
- f) The ambient temperature and hydraulic fluid temperature at the start of measuring shall be recorded.

7 Information for use

The manufacturer of the jack shall provide fitting, operating, inspection and maintenance instructions with each jack. The instructions shall draw attention to the following:

- a) the need to ensure that the load rating is appropriate for the jack's task;
- b) that there is a suitable fixing point (jack mount or mounting point) for the jack;
- c) that the jack is capable of being operated without fouling any part of the trailer or equipment;
- d) that the jack shall be securely held in the raised or storage position when not in use;
- e) where unusually soft ground conditions apply, extra support can be provided for the ground contact pad;
- f) that, if applicable, the jack crank handle does not remain in the vertical position when not in use;
- g) that if the jack is fitted with a ground contact wheel, then it is only suitable for use on hard ground;
- h) that information is to be given on how to fill hydraulic jacks with fluid and the type of fluid to be used;
- i) whenever activity requires that individuals place themselves in a position in which unexpected machinery movement can cause harm, auxiliary blocking should be used to support the implement.

Bibliography

- [1] ASAE S485, *Implement mounted, screw-type jacks*
- [2] ASTM B-117-09, *Standard practice for operating salt spray (fog) apparatus*
- [3] ISO 4254-1:2013, *Agricultural machinery — Safety — Part 1: General requirements*

.....

ICS 65.060.01

Price based on 11 pages