**Road vehicles — Connectors for the
electrical connection of towing and towed
vehicles — 15-pole connector for
vehicles with 24 V nominal supply
voltage**

*Véhicules routiers — Connecteurs pour liaisons électriques entre
véhicules tracteurs et véhicules tractés — Connecteur à 15 contacts
pour les véhicules à tension nominale de 24 V*



PDF disclaimer

This PDF file may contain embedded typefaces. In accordance with Adobe's licensing policy, this file may be printed or viewed but shall not be edited unless the typefaces which are embedded are licensed to and installed on the computer performing the editing. In downloading this file, parties accept therein the responsibility of not infringing Adobe's licensing policy. The ISO Central Secretariat accepts no liability in this area.

Adobe is a trademark of Adobe Systems Incorporated.

Details of the software products used to create this PDF file can be found in the General Info relative to the file; the PDF-creation parameters were optimized for printing. Every care has been taken to ensure that the file is suitable for use by ISO member bodies. In the unlikely event that a problem relating to it is found, please inform the Central Secretariat at the address given below.

© ISO 2004

All rights reserved. Unless otherwise specified, no part of this publication may be reproduced or utilized in any form or by any means, electronic or mechanical, including photocopying and microfilm, without permission in writing from either ISO at the address below or ISO's member body in the country of the requester.

ISO copyright office
Case postale 56 • CH-1211 Geneva 20
Tel. + 41 22 749 01 11
Fax + 41 22 749 09 47
E-mail copyright@iso.org
Web www.iso.org

Published in Switzerland

Contents

Page

Foreword	iv
1 Scope	1
2 Normative references	1
3 Terms and definitions	1
4 Dimensions	2
4.1 General	2
4.2 Plug	2
4.3 Socket	2
4.4 Park socket	2
5 Application of the connector	2
5.1 General	2
5.2 Connector positions and free space	2
5.3 Contact allocation	7
5.4 Contact designation	7
5.5 Terminals	7
5.6 Connecting cable	7
6 Tests and specific requirements	8
6.1 General	8
6.2 Mismatching	8
6.3 Connection and disconnection	8
Annex A (normative) Adaptation between 7-pole 24 N and 24 S connectors and the 15-pole connector	9

Foreword

ISO (the International Organization for Standardization) is a worldwide federation of national standards bodies (ISO member bodies). The work of preparing International Standards is normally carried out through ISO technical committees. Each member body interested in a subject for which a technical committee has been established has the right to be represented on that committee. International organizations, governmental and non-governmental, in liaison with ISO, also take part in the work. ISO collaborates closely with the International Electrotechnical Commission (IEC) on all matters of electrotechnical standardization.

International Standards are drafted in accordance with the rules given in the ISO/IEC Directives, Part 2.

The main task of technical committees is to prepare International Standards. Draft International Standards adopted by the technical committees are circulated to the member bodies for voting. Publication as an International Standard requires approval by at least 75 % of the member bodies casting a vote.

Attention is drawn to the possibility that some of the elements of this document may be the subject of patent rights. ISO shall not be held responsible for identifying any or all such patent rights.

ISO 12098 was prepared by Technical Committee ISO/TC 22, *Road vehicles*, Subcommittee SC 3, *Electrical and electronic equipment*.

This second edition cancels and replaces the first edition (ISO 12098:1994), which has been technically revised.

.....

Road vehicles — Connectors for the electrical connection of towing and towed vehicles — 15-pole connector for vehicles with 24 V nominal supply voltage

1 Scope

This International Standard gives the dimensions of, and specifies the contact allocation and tests and test requirements for, 15-pole connectors for the electrical connection of equipment other than braking systems and running gear of towing and towed vehicles with 24 V nominal supply voltage. It specifies a park socket used to receive and store the plug when disconnected, and a means of adaptation between 7-pole and 15-pole connectors.

2 Normative references

The following referenced documents are indispensable for the application of this document. For dated references, only the edition cited applies. For undated references, the latest edition of the referenced document (including any amendments) applies.

ISO 1185, *Road vehicles — Connectors for the electrical connection of towing and towed vehicles — 7-pole connector type 24 N (normal) for vehicles with 24 V nominal supply voltage*

ISO 3731, *Road vehicles — Connectors for the electrical connection of towing and towed vehicles — 7-pole connector type 24 S (supplementary) for vehicles with 24 V nominal supply voltage*

ISO 4009, *Commercial vehicles — Location of electrical and pneumatic connections between towing vehicles and trailers*

ISO 4091, *Road vehicles — Connectors for the electrical connection of towing vehicles and towed vehicles — Definitions, tests and requirements*

ISO 4141 (all parts), *Road vehicles — Multi-core connecting cables*

ISO 7638-1, *Road vehicles — Connectors for the electrical connection of towing and towed vehicles — Part 1: Connectors for braking systems and running gear of vehicles with 24 V nominal supply voltage*

ISO 7638-2, *Road vehicles — Connectors for the electrical connection of towing and towed vehicles — Part 2: Connectors for braking systems and running gear of vehicles with 12 V nominal supply voltage*

ISO 11992-1, *Road vehicles — Interchange of digital information on electrical connections between towing and towed vehicles — Part 1: Physical layer and data-link layer*

ISO 11992-3, *Road vehicles — Interchange of digital information on electrical connections between towing and towed vehicles — Part 3: Application layer for equipment other than brakes and running gear*

3 Terms and definitions

For the purposes of this document, the following terms and definitions given in ISO 4091 apply.

4 Dimensions

4.1 General

Details not specified are at the manufacturer's discretion.

The contacts shall be floating and shall align to the datum position when plug and socket are engaged.

4.2 Plug

Dimensions of the plug shall be in accordance with Figure 1. The locking lever design shall take into consideration the space required for screws used to fasten the socket (see Figure 2).

4.3 Socket

Dimensions of the socket shall be in accordance with Figure 2. The cover is shown in the open position. It shall close automatically when the plug is disconnected.

4.4 Park socket

Dimensions of the park socket shall be in accordance with Figure 3. The cover is shown in the open position. It shall close automatically when the plug is disconnected.

5 Application of the connector

5.1 General

The coiled cable assembly is fitted to the semi-trailer towing vehicle (fifth-wheel tractor) and may be connected to the electrical on-board network of the towing vehicle with or without the connection (see Figure 4).

The uncoiled cable assembly is fitted to the drawbar trailer. Therefore, the trailer towing vehicle (drawbar tractor) shall be fitted with a socket mounted at the rear of the vehicle (see Figure 4).

5.2 Connector positions and free space

The positions of and free space around the connectors shall be in accordance with ISO 4009.

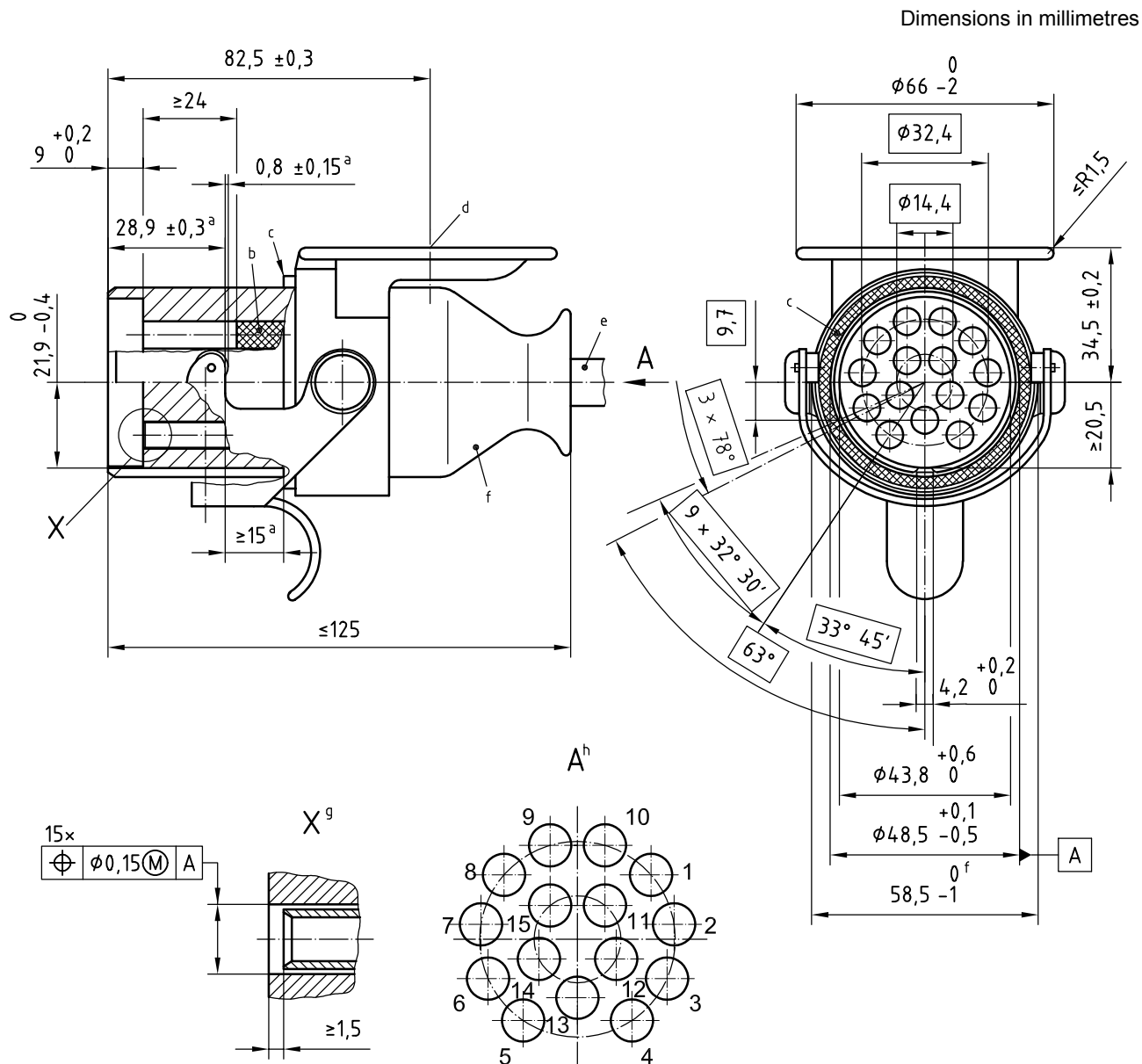

- a Dimension refers to the locking lever in its locked position.
- b If Contacts 14 and 15 are not used, blanking plugs shall, where applicable, be inserted to accept later fitment of pins and tubes.
- c The sealing ring shall be mounted such that it cannot become detached under normal use.
- d Centre of cover rest.
- e See ISO 4141-3.
- f Other housing designs are permitted provided they are in compliance with the maximum distance of 58 mm for the locking lever.
- g Spring tube.
- h Contact numbers.

Figure 1 — Plug

Dimensions in millimetres

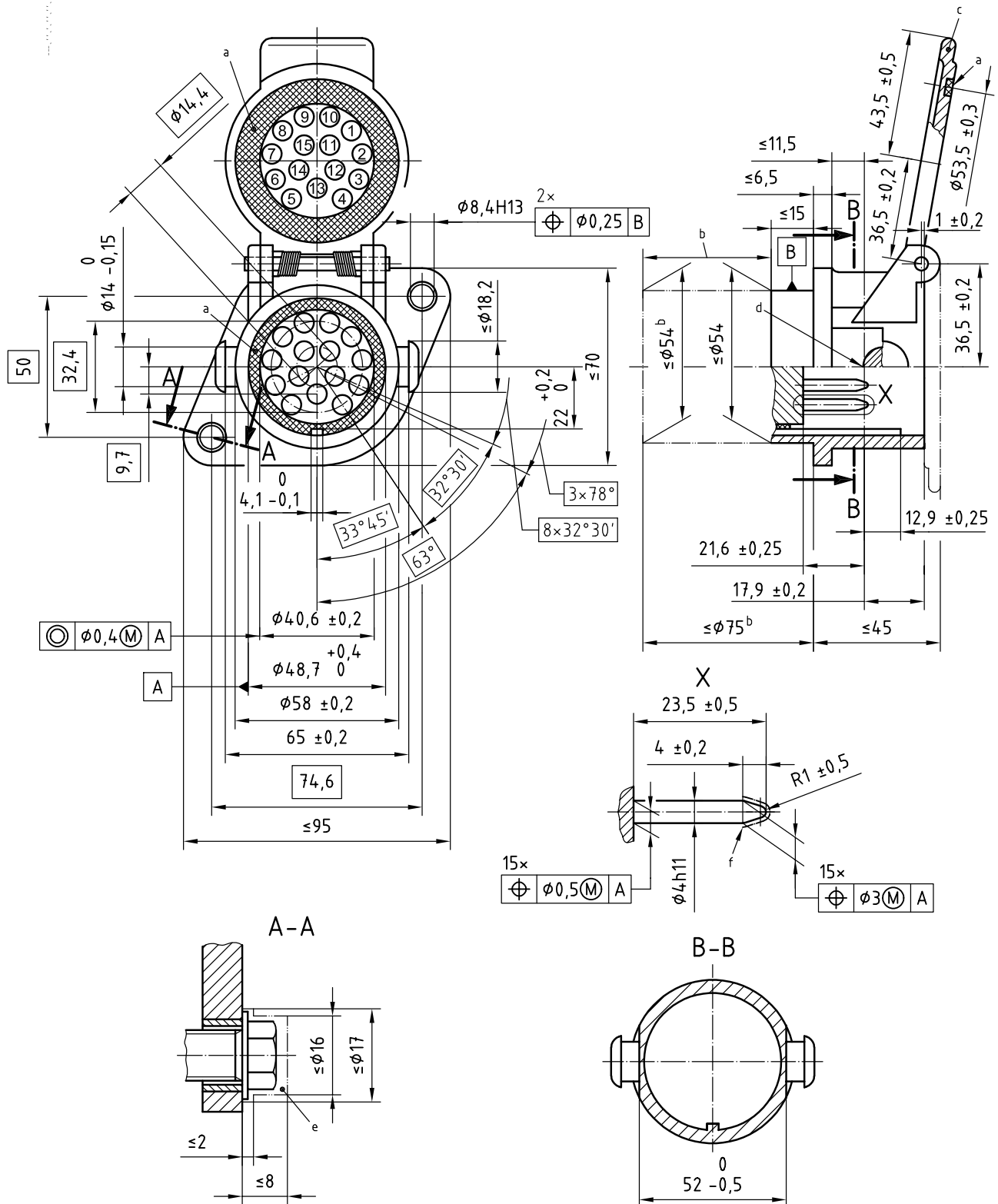

- a The sealing ring shall be mounted such that it cannot become detached under normal use.
- b For existing products for which the cable outlet is mounted from the rear, the outside diameter of the outlet may be larger with the vehicle manufacturer's agreement. However, to ensure socket exchangeability, future applications should have a maximum outside diameter of 54 mm over a maximum length of 75 mm.
- c Opening angle $\geq 120^\circ$.
- d Reference point for engaged locking lever.
- e Minimum space required for screws used to fasten the socket.
- f This area shall be smooth and burr-free.

Figure 2 — Socket

1

Dimensions in millimetres

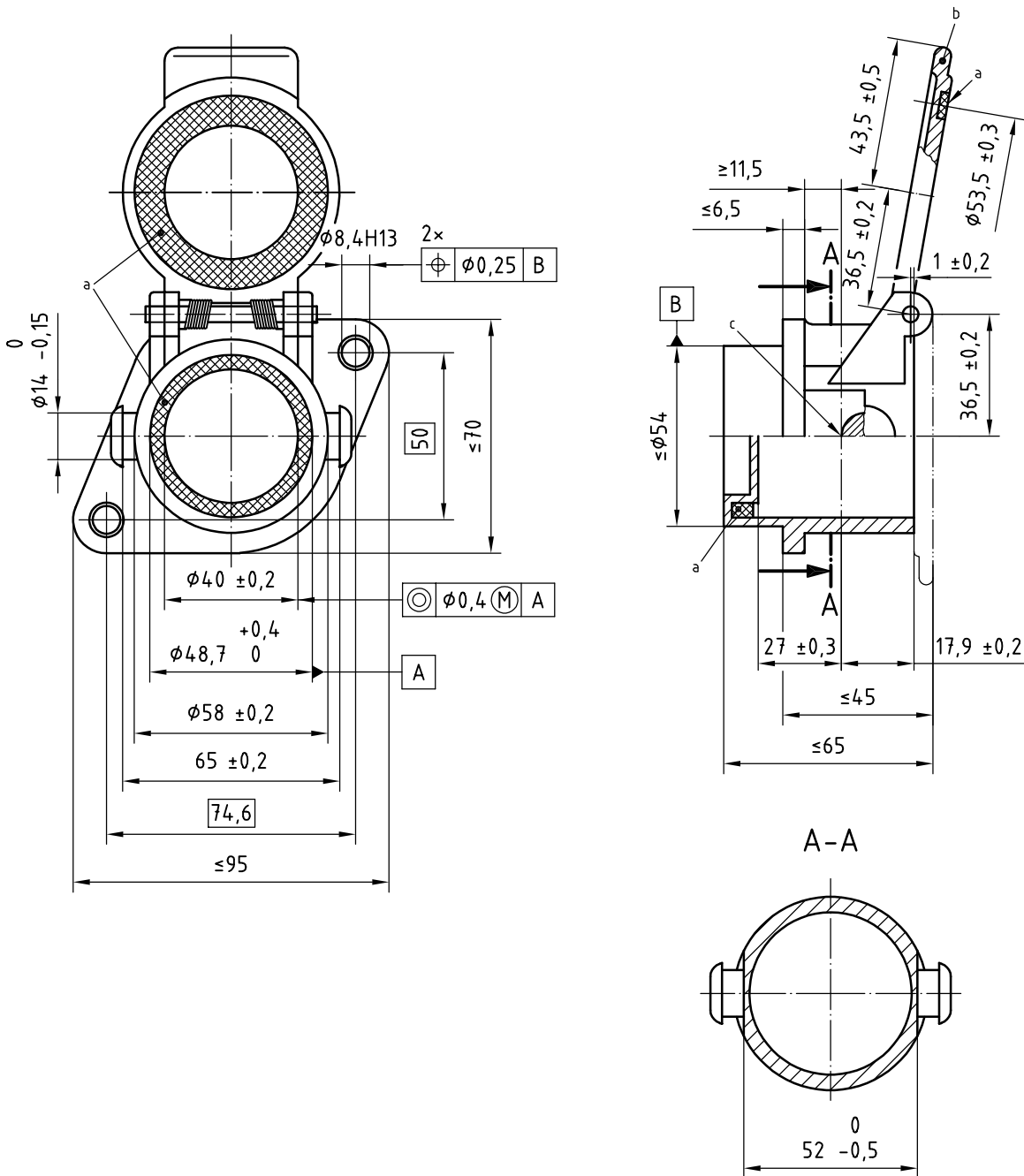

- a The sealing ring shall be mounted such that it cannot become detached under normal use.
- b Opening angle $\geq 120^\circ$.
- c Reference point for engaged locking lever.

Figure 3 — Park socket

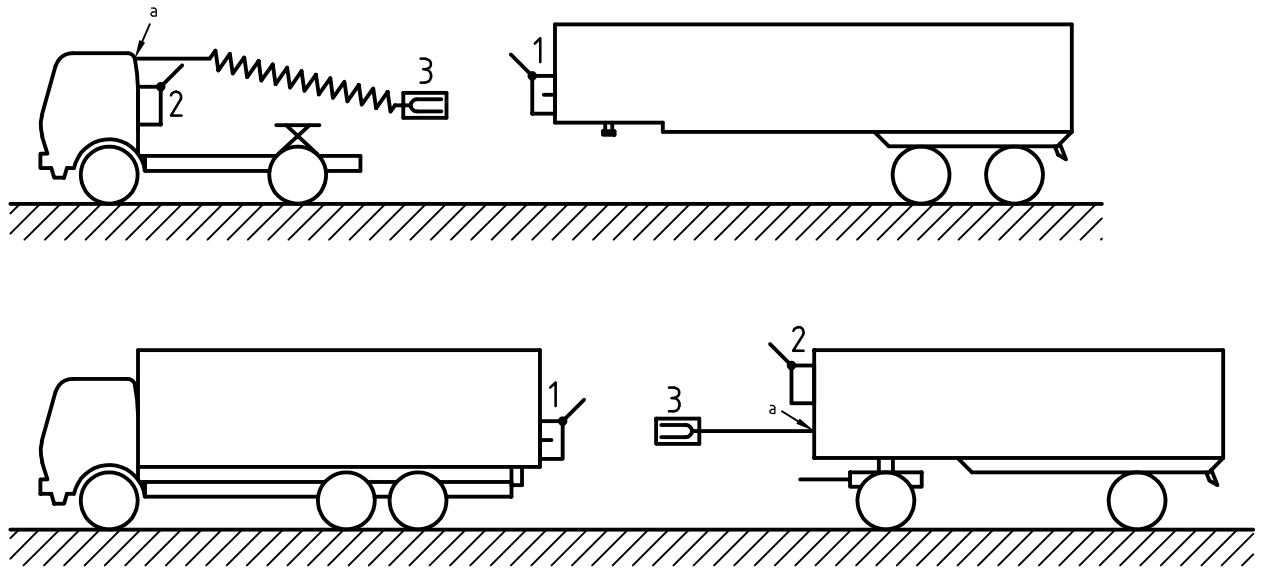

Key

- 1 socket
- 2 park socket
- 3 plug
- a See 5.1.

Figure 4 — Electrical connection positions

5.3 Contact allocation

The contact allocation shall be in accordance with Table 1.

5.4 Contact designation

The contact designation numbers shall be permanently marked on the inside of the socket cover, and on the terminal faces of both plug and socket.

The character size shall not be less than 2 mm. However, where limited space is available, a smaller size may be used on the terminal face.

5.5 Terminals

The terminals at the rear side of the pins and tubes shall be capable of accepting cables with the following nominal cross-sectional areas.

- Contacts 1, 2, 3, 5, 6, 7, 8, 10, 11, 12, 14 and 15: 1,5 mm²
- Contacts 4, 9 and 13: 2,5 mm²

Terminals accepting cables of a different cross-sectional area shall be as agreed between manufacturer and user.

5.6 Connecting cable

The connecting cable shall meet the requirements of the applicable part of ISO 4141.

Table 1 — Contact allocation

Contact No.	Function
1	Left-hand direction indicator light
2	Right-hand direction indicator light
3	Rear fog light
4	Common return for contacts 1 to 3 and 5 to 12
5	Left-hand rear positions light(s), left-hand marker lights and rear registration plate illumination ^a
6	Right-hand rear position light(s), right-hand marker lights and rear registration plate illumination ^a
7	Stop lights
8	Reversing light
9	Permanent power supply (+ 24 V)
10	Reverse lock release for inertia brake, and locking of steering axle
11	Starting-traction control system
12	Axle lifting device
13	Common return for Contact Nos. 14 and 15
14	CAN_H according to ISO 11992-1 and 11992-3, for data interchange of equipment other than braking systems and running gear
15	CAN_L according to ISO 11992-1 and 11992-3, for data interchange of equipment other than braking systems and running gear

^a The rear registration plate illumination device shall be connected such that no lamp of the device has a common connection with both Contacts 5 and 6.

6 Tests and specific requirements

6.1 General

Connectors according to this International Standard shall be tested in accordance with ISO 4091, whose requirements they shall meet except where specified differently in the following subclauses.

6.2 Mismatching

It shall be impossible to make contact between any tube or pin of the plugs and sockets according to this International Standard and the pins and tubes of connectors according to ISO 7638-1 and ISO 7638-2 without the use of excessive force.

6.3 Connection and disconnection

The connection and disconnection forces shall not exceed 100 N when tested in accordance with ISO 4091.

Annex A (normative)

Adaptation between 7-pole 24 N and 24 S connectors and the 15-pole connector

A.1 General

Commercial road vehicles with nominal 24 V supply voltage may be equipped with 7-pole 24 N or 24 S electrical connectors in accordance with ISO 1185 or ISO 3731, or with a 15-pole connector in accordance with this International Standard.

Satisfactory adaptation between 7-pole and 15-pole connectors is only feasible when the vehicles involved are equipped with connectors which fully conform to the specifications of these International Standards.

In order to ensure interchangeability between vehicles equipped with the 7-pole connectors and those equipped with the 15-pole connector, an adapter designed in accordance with the following requirements shall be used.

A.2 Basic requirement

The end of the adapter to be used for connection of the towing or towed vehicle shall be clearly identified on the adapter.

A.3 Mechanical requirements

To ensure adapter mechanical compatibility, the mating parts of the appropriate adapter shall be in accordance with the relevant dimensions and mechanical requirements specified in ISO 1185, ISO 3731 and this International Standard (see Figure A.1).

A.4 Electrical interchangeability

CAUTION — Care shall be taken as to possible effects arising from the connection of Contacts 4 and 6 of the 24 S connector by the adapter.

To ensure electrical interchangeability, the internal wiring of the appropriate adapter (Type A or B) shall be in accordance with Figures A.1 to A.3.

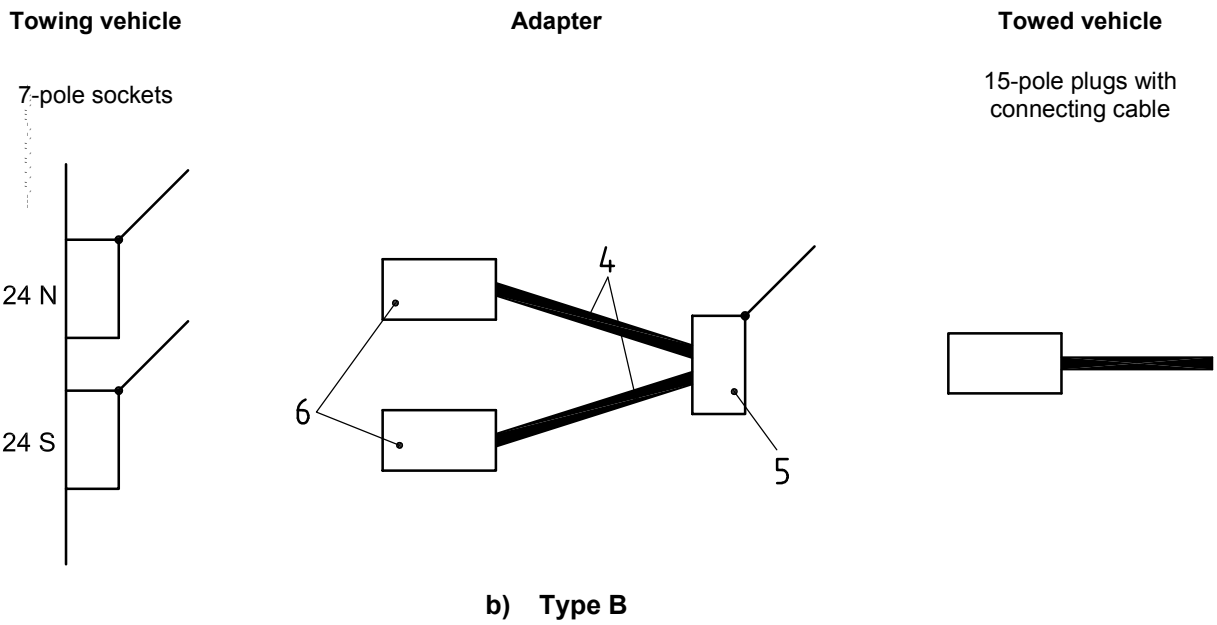
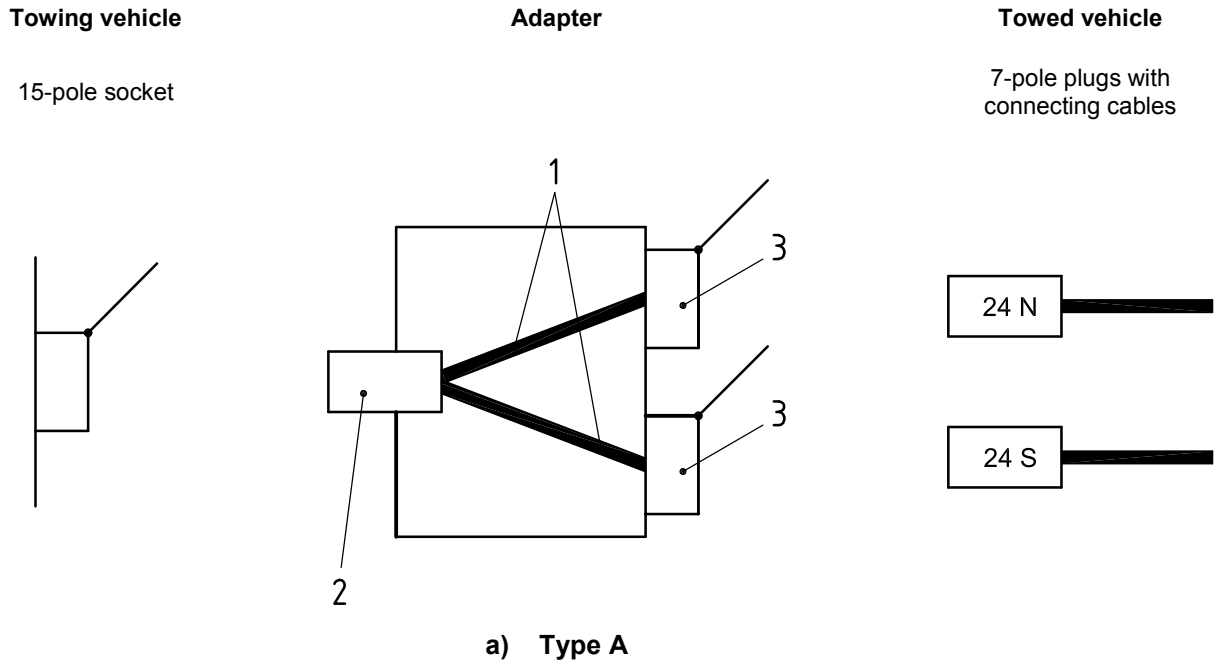

Key

- 1 connection of contacts according to Figure A.2
- 2 mating part according to plug dimensions of Figure 1
- 3 mating parts according to socket dimensions of ISO 1185 and ISO 3731
- 4 connection of contacts according to Figure A.3
- 5 mating part according to socket dimensions of Figure 2
- 6 mating parts according to plug dimensions of ISO 1185 and ISO 3731

Figure A.1 — Adapter configuration

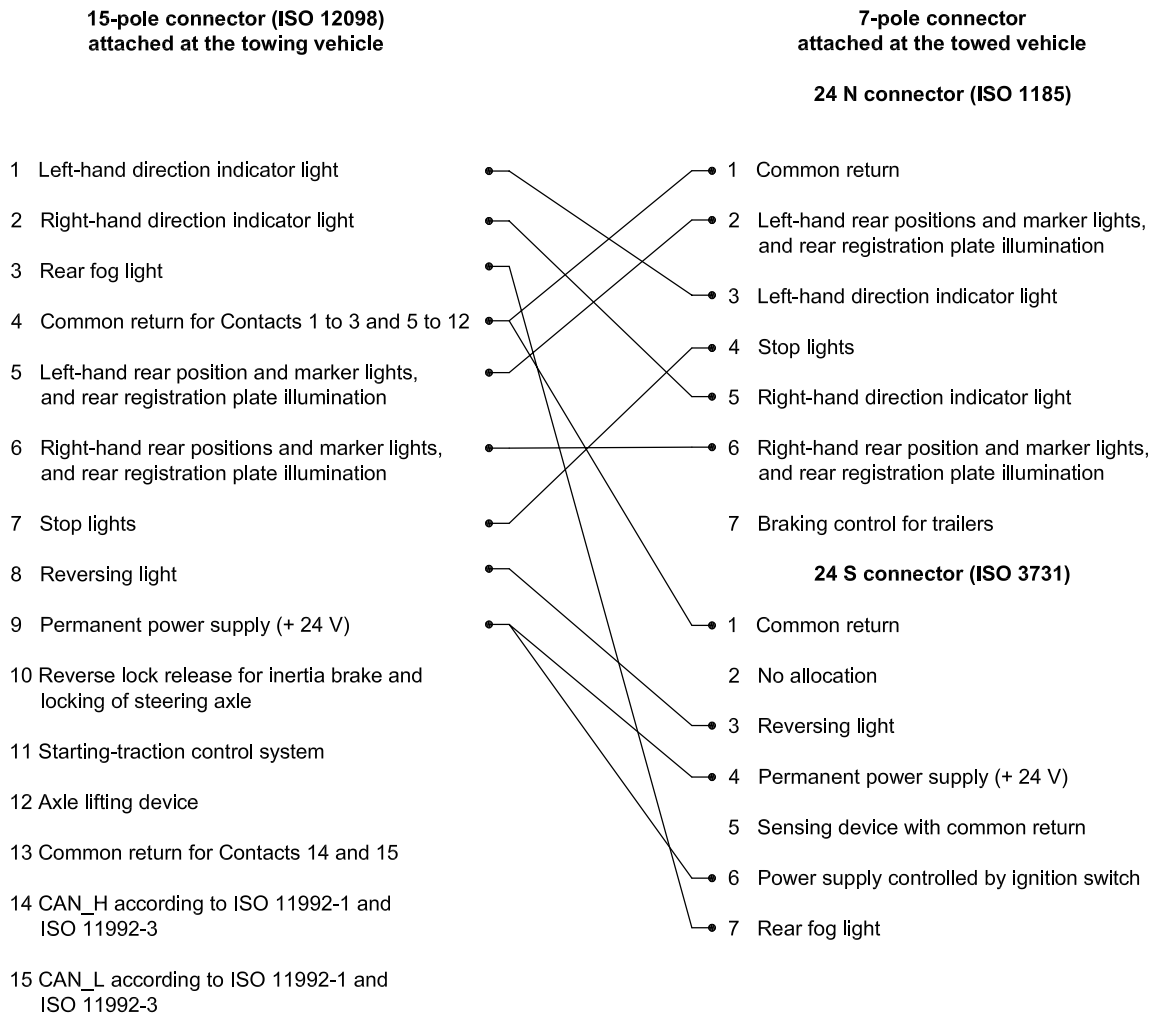

Figure A.2 — Internal wiring — Type A adapter (see Figure A.1)

7-pole connector
attached at the towed vehicle

15-pole connector (ISO 12098)
attached at the towing vehicle

24 N connector (ISO 1185)

- 1 Common return
- 2 Left-hand rear positions and marker lights, and rear registration plate illumination
- 3 Left-hand direction indicator light
- 4 Stop lights
- 5 Right-hand direction indicator light
- 6 Right-hand rear position and marker lights, and rear registration plate illumination
- 7 Braking control for trailers

24 S connector (ISO 3731)

- 1 Common return
- 2 No allocation
- 3 Reversing light
- 4 Permanent power supply (+ 24 V)
- 5 Sensing device with common return
- 6 Power supply controlled by ignition switch
- 7 Rear fog light

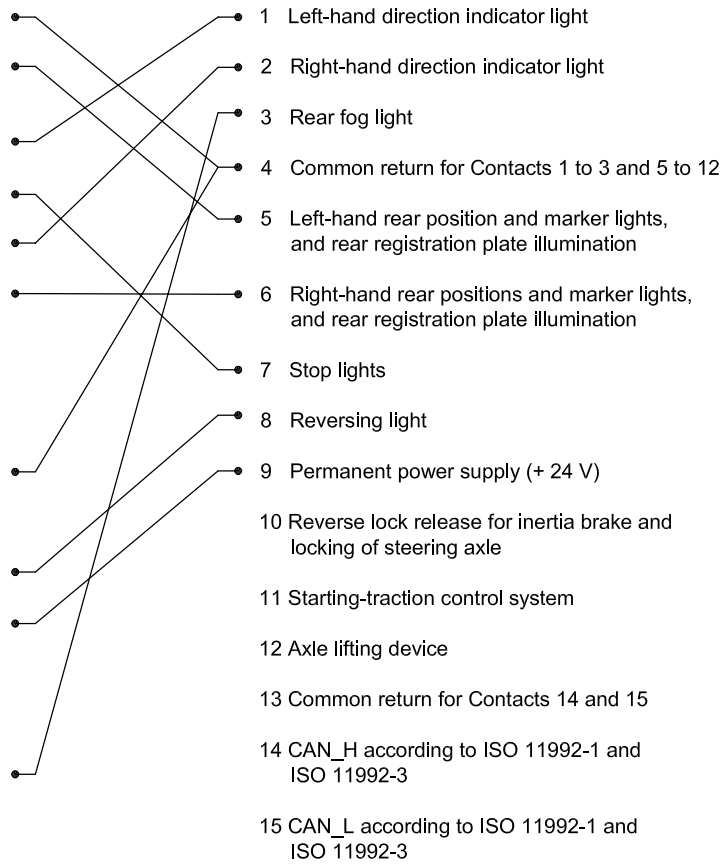

Figure A.3 — Internal wiring — Type B adapter (see Figure A.1)

ICS 43.040.10

Price based on 12 pages