

INTERNATIONAL
STANDARD

ISO
12097-2

First edition
1996-08-15

WARNING
A COPY OF THIS DOCUMENT IS NOT
ALWAYS THE LATEST VERSION

Road vehicles — Airbag components —

Part 2:
Testing of airbag modules

Véhicules routiers — Composants des sacs gonflables —
Partie 2: Essais des modules de sac gonflable



Reference number
ISO 12097-2:1996(E)

Contents

| | Page |
|---------------------------------------------------|------|
| 1 Scope | 1 |
| 2 Normative references | 1 |
| 3 Definitions | 1 |
| 4 General test conditions | 1 |
| 4.1 Purpose of environmental testing | 1 |
| 4.2 Test sequence | 2 |
| 4.3 Measurements and test report | 3 |
| 4.4 Test programme | 3 |
| 5 Environmental testing | 3 |
| 5.1 Drop test | 3 |
| 5.2 Mechanical impact test | 4 |
| 5.3 Dust test | 7 |
| 5.4 Simultaneous vibration temperature test | 8 |
| 5.5 Thermal humidity cycling test | 9 |
| 5.6 Salt spray test | 10 |
| 5.7 Solar radiation simulation test | 12 |
| 5.8 Temperature shock test | 13 |
| 6 Performance testing | 14 |
| 6.1 Static deployment test | 14 |
| 6.2 Tank test | 15 |
| 6.3 Bag test | 16 |

© ISO 1996

All rights reserved. Unless otherwise specified, no part of this publication may be reproduced or utilized in any form or by any means, electronic or mechanical, including photocopying and microfilm, without permission in writing from the publisher.

International Organization for Standardization
Case Postale 56 • CH-1211 Genève 20 • Switzerland

Printed in Switzerland

Annexes

| | | |
|----------|--------------------------------------------------------|-----------|
| A | Determination of temperature build-up time t_g | 17 |
| B | Origin of environmental test procedures | 19 |
| C | Bibliography | 20 |

Foreword

ISO (the International Organization for Standardization) is a worldwide federation of national standards bodies (ISO member bodies). The work of preparing International Standards is normally carried out through ISO technical committees. Each member body interested in a subject for which a technical committee has been established has the right to be represented on that committee. International organizations, governmental and non-governmental, in liaison with ISO, also take part in the work. ISO collaborates closely with the International Electrotechnical Commission (IEC) on all matters of electrotechnical standardization.

Draft International Standards adopted by the technical committees are circulated to the member bodies for voting. Publication as an International Standard requires approval by at least 75 % of the member bodies casting a vote.

International Standard ISO 12097-2 was prepared by Technical Committees ISO/TC 22, *Road vehicles*, Subcommittee SC 12, *Restraint systems*.

ISO 12097 consists of the following parts, under the general title *Road vehicles — Airbag components*:

- *Part 1: Vocabulary*
- *Part 2: Testing of airbag modules*
- *Part 3: Testing of inflator assemblies*

Annex A forms an integral part of this part of ISO 12097. Annexes B and C are for information only.

Road vehicles — Airbag components —

Part 2: Testing of airbag modules

1 Scope

This part of ISO 12097 establishes uniform test methods and specifies environmental procedures and requirements for airbag modules in road vehicles.

Part 3 of ISO 12097 covers testing of inflator assemblies.

2 Normative references

The following standards contain provisions which, through reference in this text, constitute provisions of this part of ISO 12097. At the time of publication, the editions indicated were valid. All standards are subject to revision, and parties to agreements based on this part of ISO 12097 are encouraged to investigate the possibility of applying the most recent editions of the standards indicated below. Members of IEC and ISO maintain registers of currently valid International Standards.

ISO 6487:1987, *Road vehicles — Measurement techniques in impact tests — Instrumentation*.

ISO 12103-1:—¹⁾, *Road vehicles — Test dust for filter evaluation — Part 1: Arizona test dust*.

3 Definitions

For the purposes of this part of ISO 12097, the definitions given in ISO 12097-1 and the following definitions apply.

3.1 airbag module: Assembly consisting of at least an inflator assembly and a bag with a cover, if applicable.

3.1.1 driver airbag module: Airbag module which is normally installed in the steering wheel.

3.1.2 front passenger airbag module: Airbag module which is normally installed ahead of the front seat passenger.

3.2 unexposed sample: Test sample not subjected to environmental testing. (Also referred to as baseline.)

3.3 exposed sample: Test sample subjected to environmental testing.

3.4 intact: State of the test sample, after completion of the test, in which the sample is sufficiently undamaged to enable the test sequence to continue.

4 General test conditions

CAUTION — There is a possibility of accidental firing of the airbag during any of the tests described in this part of ISO 12097. Appropriate precautions should therefore be taken both in terms of handling the module and in terms of the design of test equipment.

4.1 Purpose of environmental testing

Environmental tests simulate the effects of environmental loads on the airbag module with respect to its functional behaviour and service life.

The tests are based on the typical life cycle of an airbag module covering shipping, storage, mounting into the vehicle and operation, maintenance, and repair of the vehicle.

1) To be published.

The complete environmental test programme is composed of individual test methods which simulate automobile related influences such as mechanical shocks and vibration, heat and cold, humidity, sunlight, dust and corrosive agents.

Simulating the total service life may require more severe test levels than those seen in real world conditions to accelerate ageing and degradation processes.

The environmental test programme for airbag modules as specified in this part of ISO 12097 shall be a minimum requirement to ensure the verification of environmental robustness.

Table 1 gives an overview of the complete test programme applied to 10 identical test samples.

Table 2 lists the performance tests which shall be applied to 10 exposed samples and additionally to nine unexposed samples.

4.2 Test sequence

It is imperative that the sequence of the tests, Nos. 1, 2, 3, 6, 7 and 8, is in accordance with table 1. The sequence of tests 4 and 5 may be reversed if required.

The test purpose and sequence are based on life cycle considerations and on possible failure mechanisms which are described in 4.2.1 to 4.2.6.

4.2.1 The drop test and the mechanical impact test reflect handling, transportation and mounting which occur mainly during an early stage of the life cycle.

4.2.2 Dust may penetrate during all phases of the life cycle. It is important to carry out the dust test before the vibration test because of the damaging effect of abrasive particles. However, the dust test is performed after the mechanical impact test which can cause fissures, cracks and sealing damages.

Table 1 — Airbag module environmental test programme

| Test No. | Test | Subclause | Sample number | | | | | | | | | | | | | | | | | | |
|----------|--------------------------------------------------------|-----------|-----------------|---|---|---|---|---|---|---|---|----|-------------------|----|----|----|----|----|----|----|----|
| | | | Exposed samples | | | | | | | | | | Unexposed samples | | | | | | | | |
| | | | 1 | 2 | 3 | 4 | 5 | 6 | 7 | 8 | 9 | 10 | 11 | 12 | 13 | 14 | 15 | 16 | 17 | 18 | 19 |
| 1 | Drop test | 5.1 | x | x | x | x | x | x | x | x | | | | | | | | | | | |
| 2 | Mechanical impact test at - 35 °C 23 °C 85 °C | 5.2 | | x | x | x | x | x | x | x | x | x | | | | | | | | | |
| 3 | Dust test | 5.3 | x | x | x | x | x | x | x | x | | | | | | | | | | | |
| 4 | Simultaneous vibration temperature test | 5.4 | x | x | x | x | x | x | x | x | | | | | | | | | | | |
| 5 | Thermal humidity cycling test | 5.5 | x | x | x | x | x | x | x | x | | | | | | | | | | | |
| 6 | Salt spray test | 5.6 | x | x | x | x | x | x | x | x | | | | | | | | | | | |
| 7 | Solar radiation simulation test | 5.7 | | | | | | | | | | | | | | | | x | x | | |
| 8 | Temperature shock test | 5.8 | | | | | | | | | | | | | | | | x | x | | |

Table 2 — Performance test programme

| Test No. | Test | Subclause | Sample number | | | | | | | | | | | | | | | | | | |
|----------|--------------------------------------------------------|-----------|-----------------|---|---|---|---|---|---|---|---|----|-------------------|----|----|----|----|----|----|----|----|
| | | | Exposed samples | | | | | | | | | | Unexposed samples | | | | | | | | |
| | | | 1 | 2 | 3 | 4 | 5 | 6 | 7 | 8 | 9 | 10 | 11 | 12 | 13 | 14 | 15 | 16 | 17 | 18 | 19 |
| 1 | Static deployment test at - 35 °C 23 °C 85 °C | 6.1 | x | | | | | | | | | | | | | | | | | | |
| 2 | Tank test at - 35 °C 85 °C | 6.2 | | x | | | | | | | | | | | | | | | | | |
| 3 | Bag test | 6.3 | | | x | x | | | | | | | | | | | | | | | |
| 4 | Spare units | — | | | | | | | | | | | | | | | | | x | | |

4.2.3 The simultaneous vibration temperature test simulates the combined action of vibration and temperature which occurs during the life cycle. Dynamic loads during driving can be described as broadband random vibrations. Additionally, increased vibration levels occur at several characteristic frequency ranges. Dynamic loads may cause damage due to friction, abrasion, fatigue, and other effects. It is important to apply vibrations to the test sample at various temperatures, as many of the materials, especially polymers, have mechanical properties which vary with temperature. A simultaneous vibration/temperature regime simulates the real vehicle environment.

4.2.4 The thermal humidity cycling test simulates changing climatic influences with special emphasis on the penetration of water into the module during periods when the airbag module temperature is below the dew-point temperature of the ambient air. This test can cause electrical failures, material swelling, shrinking, corrosion and fouling due to biodegradation.

4.2.5 Salt spray is an accelerating agent for any kind of chemical alteration, especially for corrosion. The salt spray test is used to identify compatibility of the airbag module materials.

4.2.6 The solar radiation simulation test and the temperature shock test serve to determine the ageing behaviour of polymer parts, in their original installation equipment and types of mounting. Complex groups of components are used, and it is therefore suitable to establish the reciprocal effects of various materials within a component, or between several components. This test is used to evaluate changes in all the characteristics relevant to use and the consequences of various thermal expansions through the effects of synthetic global irradiation, heat/cold and humidity.

4.3 Measurements and test report

The following items shall be measured and recorded on a data sheet before and/or during each test of table 1:

- test number, sample number, test temperature and date;
- visual inspection of the samples and, if necessary, photographic documentation;
- definition of the three main axes (see example in figure 1);
- ambient temperature during the test in degrees Celsius (°C);
- squib resistance of the inflator assembly (if applicable).

All relevant observations and any unusual event shall be noted and included in the test report.

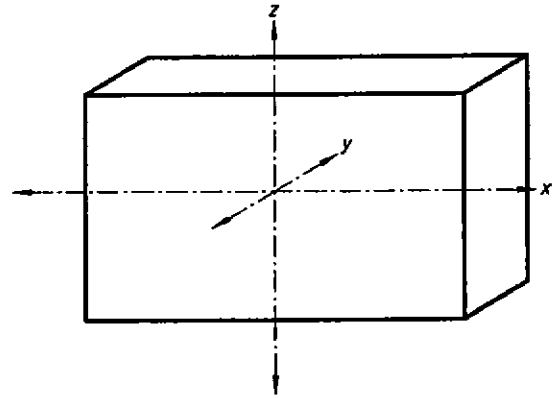

Figure 1 — Definition of airbag module main axes

4.4 Test programme

This part of ISO 12097 specifies a test programme with 19 identical samples of an airbag module that are numbered in accordance with table 1 and table 2. Ten airbag modules are subjected to the environmental test programme (multiple exposure) and nine airbag modules are unexposed samples.

The plug and ignition cable shall be connected, if applicable; the test current (an example is shown in figure 2) shall be applied according to the system used (with the exception of the mechanical impact test, the drop test, the solar radiation simulation test and the temperature shock test). After each test measure and record the squib resistance.

5 Environmental testing

The following test procedures are based on the documents listed in annex B. Certain modifications from these International Standards were made in order to recognize vehicle specific conditions.

5.1 Drop test

5.1.1 General

The purpose of this test is to determine whether the complete airbag module experiences any detrimental effect when dropped from a specified height and orientation.

5.1.2 Equipment

A steel impact plate of minimum dimensions 1 m x 1 m x 10 mm, resting on a solid floor and a fixture that supports the sample at the specified height shall be used.

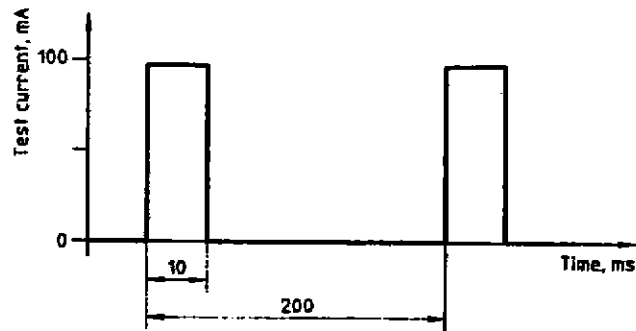

Figure 2 — Example of a test current for environmental simulation

5.1.3 Test sample

Eight airbag modules shall be tested in the sequence given in table 1.

5.1.4 Test conditions

Drop height: $1 \text{ m} \begin{smallmatrix} +0,2 \\ 0 \end{smallmatrix} \text{ m}$

The ambient temperature shall be $(23 \pm 5) \text{ }^\circ\text{C}$

5.1.5 Test procedure

Mount test sample No. 1 onto the support fixture at the specified height above the impact plate and oriented such that it will fall in one of the six directions indicated in figure 1. Disarm the trigger device, if included in the module.

Release the module, allowing it to free fall onto the impact plate. Repeat the test using test samples Nos. 2 to 8, each arranged to fall in a different direction as follows:

- along one of the remaining directions indicated in figure 1, for samples Nos. 2 to 6;
- along two other appropriate directions selected by the test engineer, for samples Nos. 7 and 8.

5.1.6 Requirements

On completion of the test, the airbag module shall be intact (3.4).

Any visible damage shall be noted. The unit under test must continue the test programme according to table 1 even if there is visible damage. It is permissible to repair any damage to the airbag module which prevents mounting, to allow the test to proceed.

5.2 Mechanical impact test

5.2.1 General

The purpose of this test is to determine whether the complete airbag module experiences any detrimental

effect when subjected to a series of shock impacts at normal and extreme temperatures.

5.2.2 Equipment

A climate chamber shall be used which is capable of maintaining the test conditions stated in 5.2.4.

A shock testing machine, onto which an airbag module can be fastened to its fixture or table, shall be used.

The characteristics of the shock testing machine shall be such that the true value of the actual pulse, as measured in the intended direction at the check point, is within the tolerances shown in figure 3.

The check point is the fixing point of the airbag module which is nearest to the centre of the table surface of the shock testing machine, unless there is a fixing point having a more rigid connection to the table, in which case this latter point shall be used. The frequency response of the overall shock testing machine, which includes the accelerometer, can have a significant effect on accuracy and shall be within the limits shown in figure 4.

5.2.3 Preparation of test sample

Eight airbag modules shall be preconditioned at each of the following temperatures:

$(-35 \pm 2,5) \text{ }^\circ\text{C}$

$(23 \pm 5) \text{ }^\circ\text{C}$

$(85 \pm 2,5) \text{ }^\circ\text{C}$

Before mounting onto the test rig, each sample shall be preconditioned in the climate chamber at the required temperature for at least 4 h or for the time t_e , which is determined in accordance with the procedure specified in annex A.

NOTE 1 The reference point for measuring t_e should be at the slowest point of temperature adaptation within the bag folded into the airbag module.

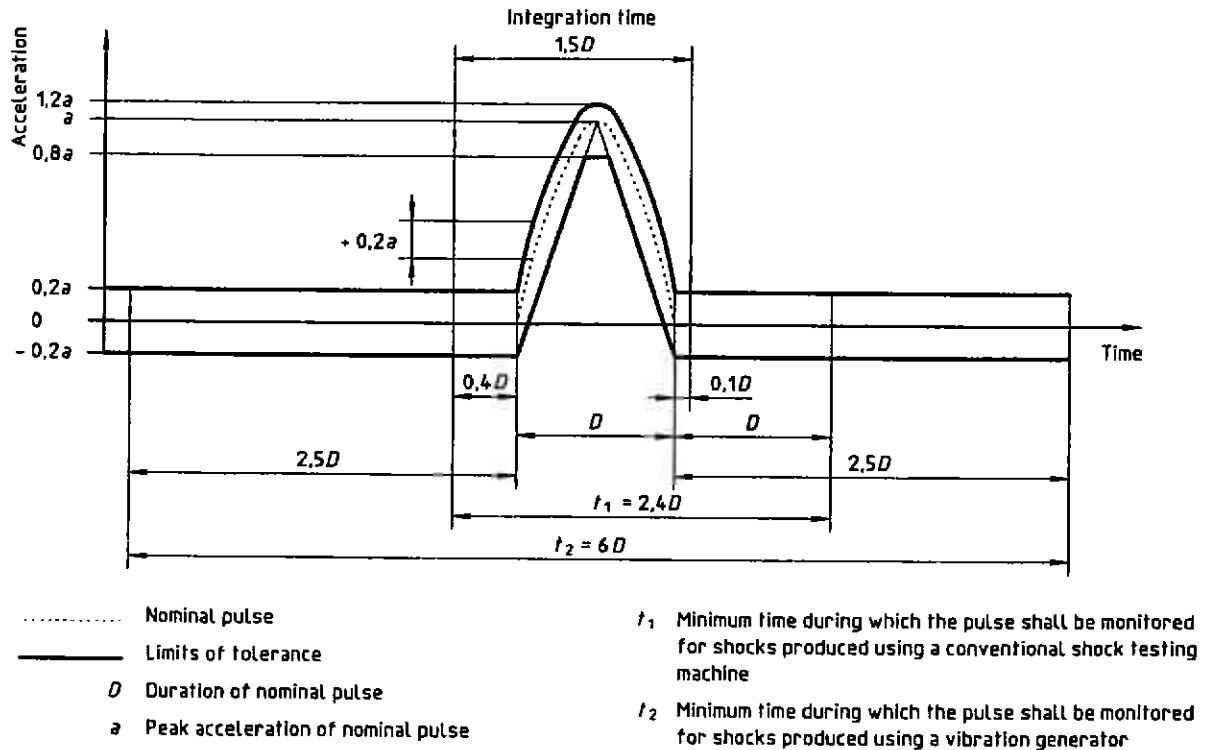

Figure 3 — Half-sine pulse

5.2.4 Test conditions

Each airbag module shall be subjected to a total of 36 shocks; 12 shocks at each of the test temperatures. Each series of 12 shocks consists of two successive shocks applied in each direction of the three mutually perpendicular axes of the airbag modules (see figure 1).

5.2.5 Test procedure

The 24 airbag modules shall be tested in the sequence given in table 1. Each airbag module is mounted outside the climate chamber on the test rig and subjected to the test conditions specified in 5.2.4. However, if the climate chamber is large enough, the test may be conducted inside it.

Airbag modules which include a trigger device shall be tested in the disarmed condition.

Consecutive impact tests can be conducted outside the climate chamber. After 5 min the airbag module shall be reconditioned for 10 min, or for the time t_e , which is determined in accordance with the procedure specified in annex A.

5.2.5.1 Basic pulse shape

The applied pulse shall be a half-sine (see figure 3). The true value of the actual pulse shall be within the limits of tolerance shown by the solid lines in figure 3.

5.2.5.2 Velocity change tolerance

The actual velocity change at the pulse shall be within $\pm 15\%$ of the value corresponding to the nominal pulse. Where the velocity change is determined by integration of the actual pulse, this shall be done from $0.4D$ before the pulse to $0.1D$ beyond the pulse, where D is the duration of the nominal pulse.

5.2.5.3 Transverse motion

The positive or negative peak acceleration at the check point, perpendicular to the intended shock direction, shall not exceed 30% of the value of the peak acceleration at the nominal pulse in the intended direction, when determined with a measuring system in accordance with 5.2.2.

5.2.5.4 Severity

The shock severity shall correspond to the values of table 3.

5.2.6 Requirements

On completion of the test, the airbag module shall be intact (3.4).

Any visible damage shall be noted. The unit under test must continue the test programme according to table 1 even if there is visible damage. It is permissible to repair any damage to the airbag module which prevents mounting, to allow the test to proceed.

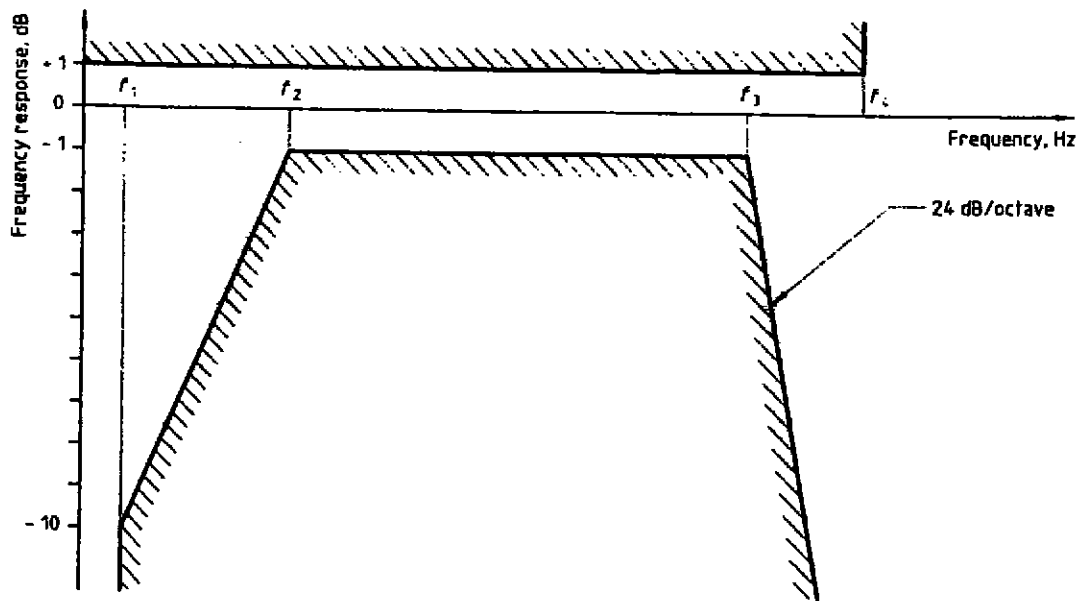

| Duration of pulse ms | Low-frequency cut-off | | High-frequency cut-off | Frequency beyond which the response may rise above + 1 dB |
|-------------------------|-----------------------|-------|------------------------|--------------------------------------------------------------|
| | f_1 | f_2 | f_3 | f_4 |
| 0,2 | 20 | 120 | 20 | 40 |
| 0,5 | 10 | 50 | 15 | 30 |
| 1 | 4 | 20 | 10 | 20 |
| 3 | 2 | 10 | 5 | 10 |
| 6 | 1 | 4 | 2 | 4 |
| 11 | 0,5 | 2 | 1 | 2 |
| 18 and 30 | 0,2 | 1 | 1 | 2 |

NOTE — For shocks of duration equal to or less than 0,5 ms, the values of f_3 and f_4 indicated in this figure may be unnecessarily high. In such instances the relevant specification should state which alternative values are to be adopted.

Figure 4 — Frequency characteristics of the measuring system

Table 3 — Shock severity levels

| Parameter | Driver airbag module | Front passenger airbag module | Other types of airbag module |
|-----------------------------------------|----------------------|-------------------------------|--------------------------------------|
| Peak acceleration of nominal pulse, a | 100g ¹⁾ | 40g | Specific values are to be determined |
| Duration of the nominal pulse, D | 6 ms | 6 ms | |

1) Lower g levels (minimum 40g) may be appropriate for certain types of steering column.

5.3 Dust test

5.3.1 General

The purpose of this test is to determine whether the complete airbag module experiences any detrimental effect when subjected to a dust environment.

5.3.2 Equipment

A test chamber as shown in figure 5 shall be used. The dust used shall consist of approximately 1 kg of ISO 12103-1-A4 test dust (coarse grade).

Dimensions in millimetres

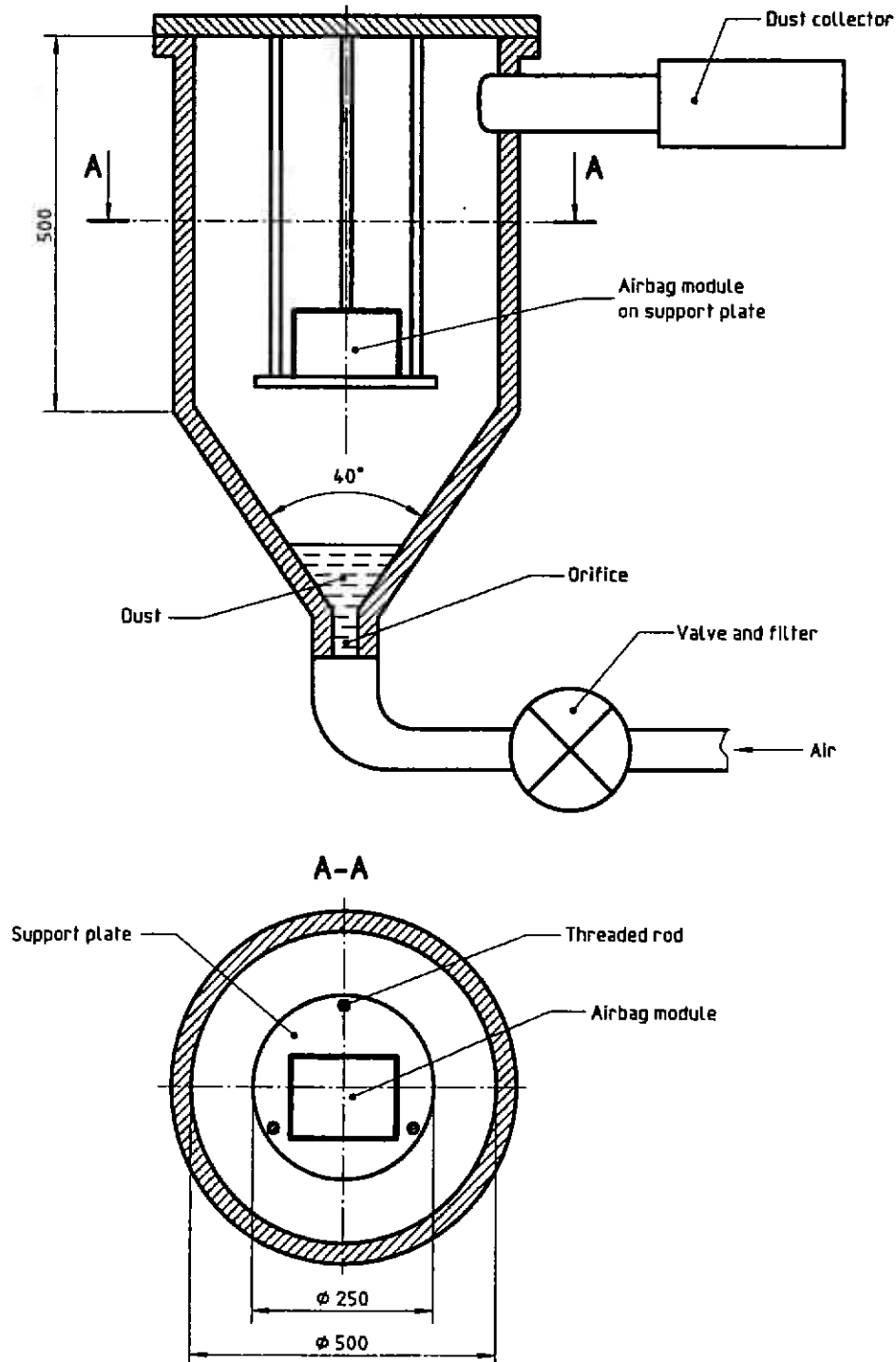

Figure 5 — Dust test chamber

5.3.3 Test sample

Eight airbag modules shall be tested in the sequence given in table 1.

5.3.4 Test conditions

The airbag modules shall be mounted in an orientation similar to that in which they are mounted in the vehicle.

5.3.5 Test procedure

The airbag modules shall be positioned in the test chamber. For a period of 5 h, the dust shall be agitated every 20 min for 5 s by compressed air free of oil and moisture at a gauge pressure of (550 ± 50) kPa¹⁾ entering through an orifice of diameter $(1,5 \pm 0,1)$ mm.

5.3.6 Requirements

On completion of the test, the airbag module shall be intact (3.4).

Any visible damage shall be noted. The unit under test must continue the test programme according to table 1 even if there is visible damage. It is permissible to repair any damage to the airbag module which prevents mounting, to allow the test to proceed.

5.4 Simultaneous vibration temperature test

5.4.1 General

The purpose of this test is to determine the ability of the airbag module to withstand combined vibration and temperature conditions.

5.4.2 Equipment

A vibration table mounted within a climate chamber capable of maintaining the temperature during the test in accordance with 5.4.4.2 shall be used. The table shall be capable of producing the vibration loads specified in 5.4.4.1.

5.4.3 Test sample

Eight airbag modules shall be tested in the sequence given in table 1.

5.4.4 Test conditions

5.4.4.1 Vibration load

Random vibration shall be applied according to figure 6. Alternatively, a vehicle specific or driving condition specific vibration load more severe than that specified (e.g. r.m.s. > 1,34g) in figure 6 may be used, subject to agreement between the airbag module supplier and the client.

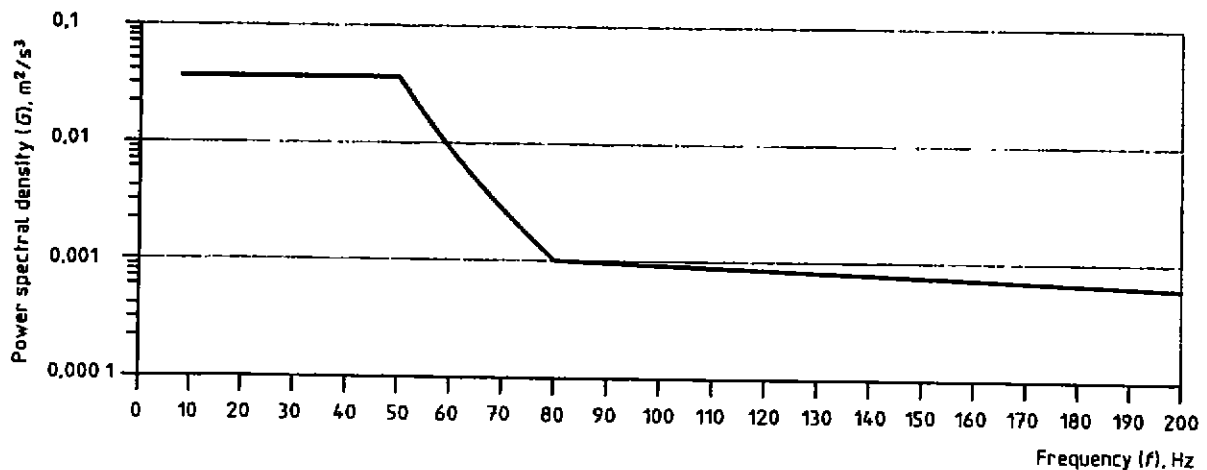

number of lines: 400
 range of analysis: 500 Hz
 (filter bandwidth 1,25 Hz)
 degrees of freedom: 154
 abort limits lines: ± 5 dB
 abort limits of acceleration (r.m.s.): ± 5 dB

| | | | | |
|----------------------------------------------|-------|-------|-------|---------|
| <i>f</i> , Hz | 8 | 50 | 80 | 200 |
| <i>G</i> , (m ² /s ³) | 0,035 | 0,035 | 0,001 | 0,000 5 |
| r.m.s. = 1,34 g | | | | |

Figure 6 — Vibration load

1) 100 kPa = 1 bar = 14,5 psi

5.4.4.2 Temperature cycle

The temperature of the chamber shall be maintained at the levels, and for the durations, shown in figure 7. The tolerance on temperature is $\pm 2,5$ °C.

5.4.5 Test procedure

Each airbag module is subjected to the specified vibration load in each of the three main axes shown in figure 1. The load shall be applied for 24 h along each of the three main axes. The temperature shall be varied simultaneously in accordance with 5.4.4.2.

5.4.6 Requirements

On completion of the test, the airbag module shall be intact (3.4).

Any visible damage shall be noted. The unit under test must continue the test programme according to table 1 even if there is visible damage. It is permissible to repair any damage to the airbag module which prevents mounting, to allow the test to proceed.

5.5 Thermal humidity cycling test

5.5.1 General

The purpose of this test is to determine the ability of an airbag module to withstand high humidity and temperature variations.

5.5.2 Equipment

A climatic chamber with recirculating air shall be used.

5.5.3 Test sample

Eight airbag modules shall be tested in the sequence given in table 1.

5.5.4 Test conditions

The temperature and relative humidity of the chamber shall be maintained at the levels, and for the durations, shown in figure 8. The tolerance on temperature is $\pm 2,5$ °C.

The relevant temperature build-up times t_0 may be used instead of the values specified in figure 8. In this case, the values shall be determined, prior to the test, by the method stated in annex A. The reference point for the determination of build-up times is the approximate point of slowest temperature adaptation on the bag (folded in the airbag module).

5.5.5 Test procedure

Put the airbag modules into the climatic chamber and subject them to 30 thermal humidity cycles in accordance with 5.5.4.

5.5.6 Requirements

On completion of the test, the airbag module shall be intact (3.4).

Any visible damage shall be noted. The unit under test must continue the test programme according to table 1 even if there is visible damage. It is permissible to repair any damage to the airbag module which prevents mounting, to allow the test to proceed.

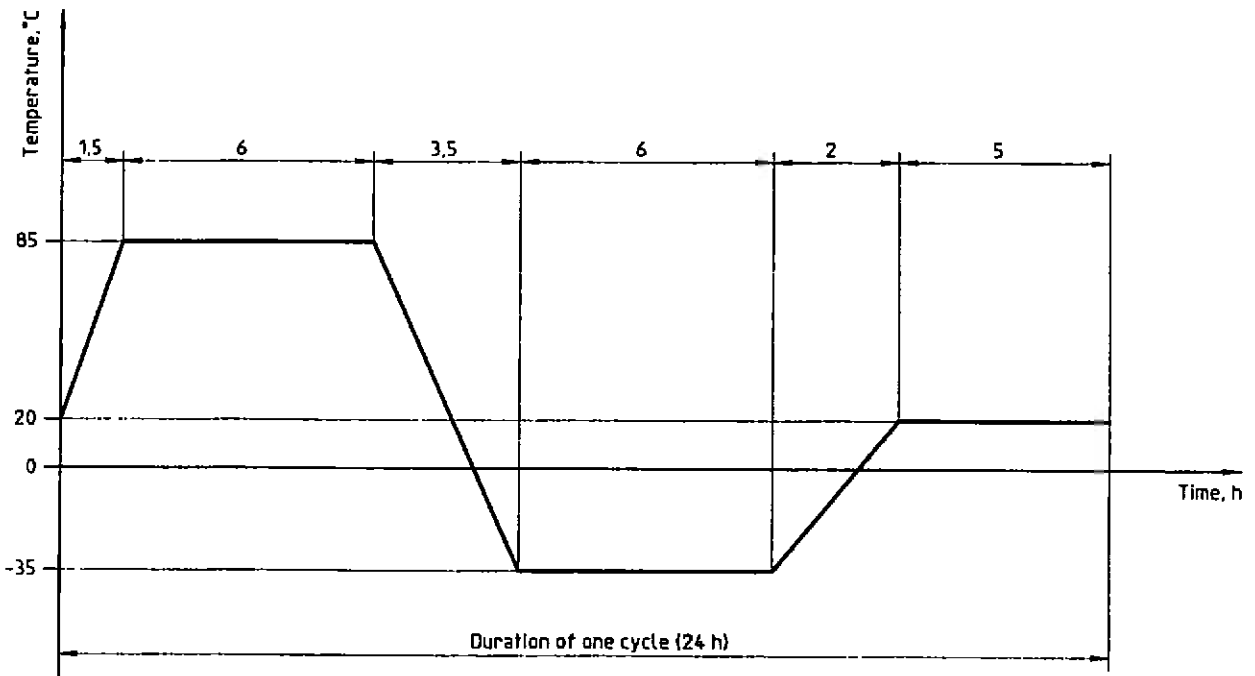
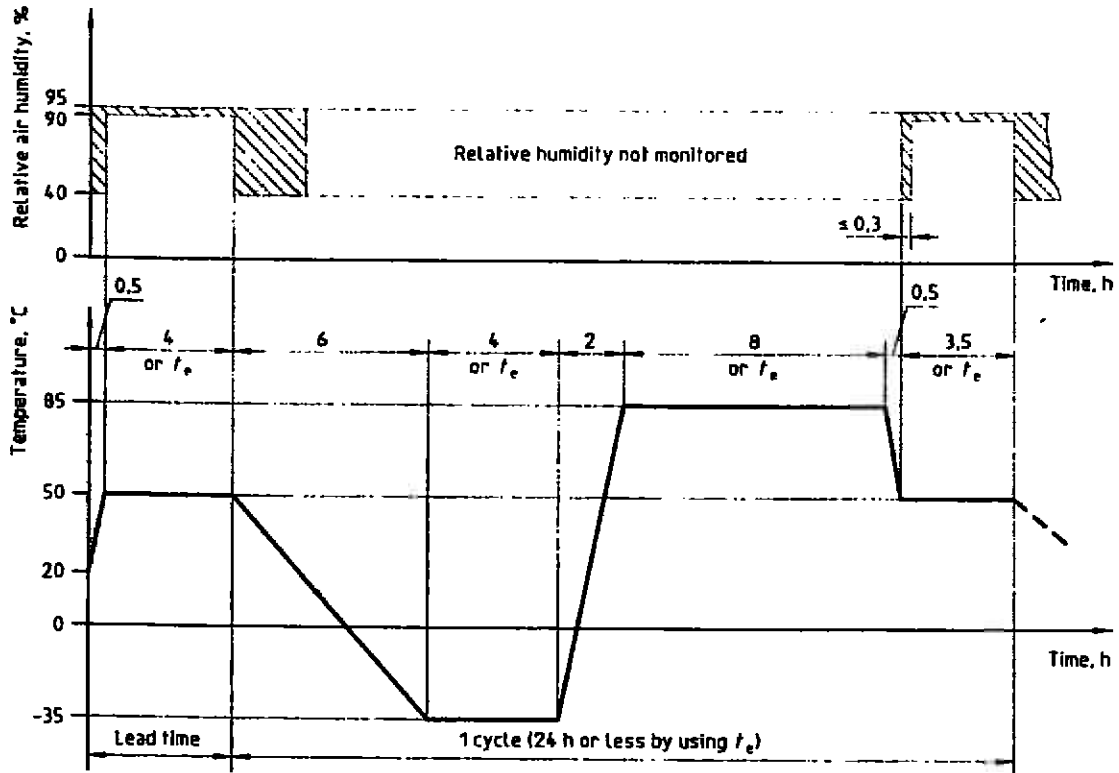

Figure 7 — Temperature cycle



NOTE — The hatched areas show the acceptable temperature changes.

Figure 8 — Thermal humidity cycle

5.6 Salt spray test

5.6.1 General

The purpose of this test is to determine the ability of the airbag module to resist corrosion.

5.6.2 Equipment

5.6.2.1 Salt mist chamber

The chamber for this test shall be constructed of such materials that will not influence the corrosive effects of the salt mist. The detailed construction of the chamber, including the method of producing the salt mist is optional, provided that:

- a) the conditions in the chamber are within the limits specified;
- b) a sufficiently large volume with constant conditions (that are not affected by turbulence and are not influenced by the specimens under test) is available;
- c) no direct spray impinges upon the specimens under test;
- d) drops of liquid accumulating on the ceiling, the walls and other parts cannot drip onto the specimens;

e) the chamber is properly vented to prevent pressure build-up and allows uniform distribution of the salt mist;

f) the discharge end of the vent is protected from strong draughts which would cause air flow in the chamber.

5.6.2.2 Atomizer(s)

The atomizer(s) shall be of such a design and construction as to produce a finely divided, wet and dense mist. The atomizer shall be made of material that is non-reactive to the salt solution.

5.6.2.3 Sprayed solution

The sprayed solution shall not be reused.

5.6.2.4 Air supply

If use is made of compressed air it shall be essentially free from all impurities, such as oil and dust, when entering the atomizer(s).

The air pressure shall be such that each atomizer produces the mist described in 5.6.2.2.

To ensure against clogging of the atomizer(s) by salt deposition, it is recommended that the air has a relative humidity of at least 85 % (at the point of release

from the nozzle). A satisfactory method of achieving this is to pass the air in very fine bubbles through a tower containing water, which should be automatically maintained at a constant level. The temperature of this water shall be not less than that of the chamber.

Means shall be provided for adjusting the air pressure such that the collection rate specified in 5.6.5 can be maintained.

5.6.2.5 Salt solution

The salt used for the test shall be high quality sodium chloride (NaCl) containing, when dry, not more than 0,1 % sodium iodide and not more than 0,3 % of total impurities. The mass fraction of the salt solution shall be (5 ± 1) %. The solution shall be prepared by dissolving 5 ± 1 parts by mass of salt in 95 parts by mass of distilled or demineralized water. The pH value of the solution shall be between 6,5 and 7,2 at a temperature of (20 ± 2) °C. The pH value shall be maintained within this range during conditioning; for this purpose, dilute hydrochloric acid or sodium hydroxide may be used to adjust the pH value, provided that the concentration of NaCl remains within the prescribed limits. The pH values shall be measured when preparing each new batch of solution.

5.6.3 Test sample

Eight airbag modules shall be tested in the sequence given in table 1.

5.6.4 Test conditions

The severity of the test is defined by the combination of the number of spraying periods and the duration of the storage period in the salt mist chamber following each spray. There shall be three spraying cycles. Each cycle consists of 2 h with the spray on, followed by a storage period of 20 h in which no spraying occurs (see figure 9).

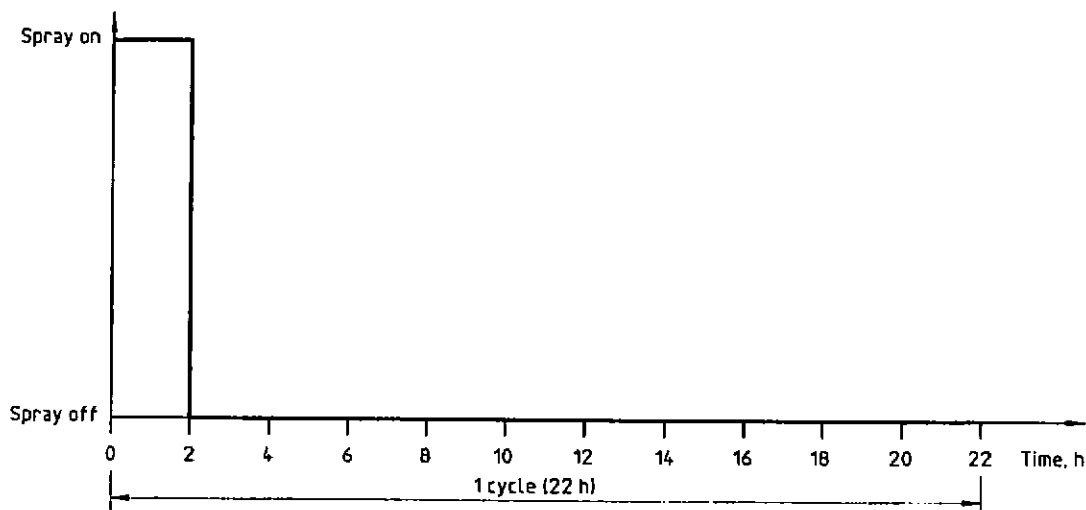

Figure 9 — Salt spray cycle

5.6.5 Test procedure

The specimens shall be placed in the salt mist chamber, and sprayed with the salt solution, in accordance with 5.6.4, at a temperature between 30 °C and 35 °C.

The salt mist conditions shall be maintained in all parts of the exposure zone, such that a clean collecting receptacle with a horizontal collecting area of 80 cm², placed at any point in the exposure zone, shall collect between 1 ml and 2 ml of salt solution per hour, averaged over the collecting period. A minimum of two receptacles shall be used. The receptacles shall be placed such that they are not shielded by the specimens and so that no condensate from any source shall be collected.

NOTE 2 When calibrating the spray rate of the chamber a minimum spraying period of 8 h should be used, for accurate measurement purposes.

The specimens shall not be in contact with each other nor with other metal parts and shall be so arranged as to exclude any influence of one part upon another.

After the last storage period, clean off the salt water with a moist sponge and dry the specimens in air at (55 ± 2) °C for 1 h.

5.6.6 Requirements

On completion of the test, the airbag module shall be intact (3.4).

Any visible damage shall be noted. The unit under test must continue the test programme according to table 1 even if there is visible damage. It is permissible to repair any damage to the airbag module which prevents mounting, to allow the test to proceed.

5.7 Solar radiation simulation test

5.7.1 General

The purpose of this test is to determine the ability of an airbag module to withstand the effects of solar radiation as experienced inside a vehicle (interior conditions). This test shall be performed on airbag modules whose padded cover is subject to direct solar radiation (airbag modules which do not meet this condition are excepted from this text).

5.7.2 Equipment

5.7.2.1 General

A test chamber shall be used which is capable of:

- maintaining temperature and relative humidity in the test cycle specified in 5.7.4;
- providing solar radiation conditions from lamps mounted on the ceiling.

5.7.2.2 Test box

The solar radiation simulation is achieved using glass filters placed directly under the lamps or by placing a glass box which contains the test samples inside the chamber.

Plain window glass of 4 mm thickness is used as the standard glass pane. Due to transmission in the UV range, the use of this glass makes it possible to simulate the worst case scenario. Of course other types of glass can be used by agreement. Although it must be considered that the use of other glass will change the transmission factor and therefore the spectral distribution. The use of other glass shall be indicated in the test report.

5.7.2.3 Radiation unit

The main components of the radiation unit are the light source, reflector systems (if required) and filter systems. The radiation unit shall provide an irradiance of $(830 \pm 80) \text{ W/m}^2$. The tolerance on irradiance at the reference plane shall be $\pm 5\%$, where the reference plane is an imaginary surface inside the empty test box at which the specified climate parameters, such as irradiance and temperature are measured.

The sensors shall be protected from direct radiation. The spectral distribution of the simulated radiation shall correspond to table 4.

5.7.3 Test sample

Two airbag modules shall be tested. In accordance with table 1 these shall be sample No. 9 and sample No. 10.

5.7.4 Test conditions

A solar radiation simulation test is conducted according to the dry climate conditions specified in figure 10.

The tolerance on temperature is $\pm 3^\circ\text{C}$.

5.7.5 Test procedure

The airbag modules are placed in the chamber or test box (5.7.2.2) in an orientation similar to that in which they are mounted in the vehicle. Before and after testing, the airbag modules shall be preconditioned for 24 h at ambient temperature.

The airbag modules are subjected to 15 dry climate cycles in accordance with figure 10.

Table 4 — Spectral distribution of the simulated radiation

| Wavelength nm | Proportion of total radiation % | Transmission of 4 mm thick glass pane % | Proportion of total radiation behind 4 mm thick glass pane % |
|------------------|------------------------------------|-----------------------------------------------|--------------------------------------------------------------------|
| 280 to 320 | $0,5 \pm 0,2$ | 0,07 | < 0,04 |
| 320 to 360 | $2,4 \pm 0,6$ | 0,61 | $1,8 \pm 0,5$ |
| 360 to 400 | $3,2^{+1,2}_{-0,8}$ 1) | 0,88 | $3,4^{+1,2}_{-0,8}$ 1) |
| 400 to 520 | $17,9 \pm 1,8$ | 0,89 | $19,2 \pm 1,9$ |
| 520 to 640 | $16,6 \pm 1,7$ | 0,89 | $17,8 \pm 1,8$ |
| 640 to 800 | $17,3^{+1,7}_{-4,5}$ 1) | 0,83 | $17,3^{+1,7}_{-4,5}$ 1) |
| 800 to 3 000 | $42,1 \pm 8,4$ | 0,80 | $40,5 \pm 8,1$ |

1) Currently available metal halogen lamps can be used to obtain this value.

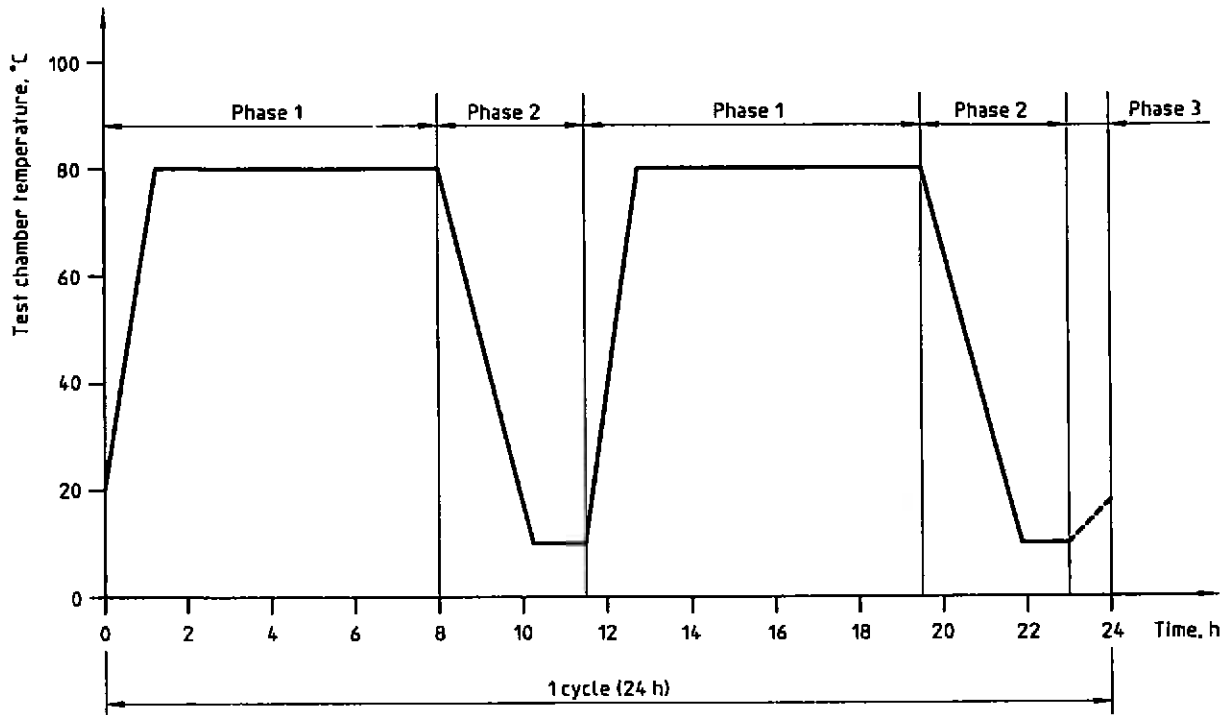

| Parameter | Phase 1 | Phase 2 | Phase 3 |
|-----------------------------------|-----------------------------|------------|-------------------------------------------------------------------------------------------|
| Irradiance | (830 ± 80) W/m ² | no | ambient climate to allow checking of the test item in the test box or in the test chamber |
| Relative humidity | < 30 % | > 55 % | |
| Heating gradient | 1 °C/min | | |
| Cooling gradient | | 0,5 °C/min | |
| Constant test chamber temperature | 80 °C | 10 °C | |
| Time | 8 h | 3,5 h | |

Figure 10 — Dry climate cycle for solar radiation simulation (interior conditions)

Temperature and relative humidity shall be recorded continuously.

Because of the unavoidable ageing and clouding of the lamps, glass filters or the glass test box, the radiation level shall be checked as follows:

- a) prior to each test, measure the spectral distribution;
- b) during each test, measure radiation at a reference point on the airbag module.

To monitor any influences, which cannot be measured, and to achieve comparable results in different test chambers, it is recommended that the exposure conditions are checked using a reference material with known ageing properties.

5.7.6 Requirements

On completion of the test, the airbag module shall be intact (3.4).

Any visible damage shall be noted. The unit under test must continue the test programme according to table 1 even if there is visible damage. It is permissible to repair any damage to the airbag module which prevents mounting, to allow the test to proceed.

5.8 Temperature shock test

5.8.1 General

The purpose of this test is to determine the ability of the airbag module to withstand major temperature changes, in particular in respect to the tear seams.

5.8.2 Equipment

Temperature chambers with recirculating air shall be used.

5.8.3 Test sample

Two airbag modules shall be tested in the sequence given in table 1.

5.8.4 Test conditions

The test cycle shall correspond to figure 11. One temperature chamber shall be maintained at the temperature $T_A = (-35 \pm 2,5) ^\circ\text{C}$, and the other chamber at $T_B = (85 \pm 2,5) ^\circ\text{C}$.

Prior to testing, determine the temperature build-up time t_e by the method given in annex A. The reference point for the determination of build-up times is a point on the inside surface of the cover that coincides with the tear seams.

5.8.5 Test procedure

Put the airbag modules in the high temperature chamber with the highest temperature (T_B) and relocate after 6 h, or the temperature build-up time t_e , to the other temperature chamber (at temperature T_A) in less than 3 min. Continue relocation of the airbag modules for 300 test cycles.

5.8.6 Requirements

On completion of the test, the airbag module shall be intact (3.4).

Any visible damage shall be noted. Particular attention shall be paid to the integrity of the tear seams.

6 Performance testing

The performance of the airbag module shall be determined in accordance with table 2 after the com-

pletion of all environmental tests. The following items shall be measured and recorded on a data sheet or high-speed film:

- squib resistance of the inflator assembly (if applicable);
- ignition time and ignition current curve plotted against time;
- bag inflation time (in accordance with 6.1);
- time at which bag cover begins to open (in accordance with 6.1).

6.1 Static deployment test

6.1.1 Driver airbag module

The airbag module shall be rigidly mounted on a fixture in the position in which it will be installed in the vehicle. Alternatively, the unit may be located in such a way that the airbag unfolds in either the vertical or the horizontal direction.

The test temperatures are:

$$\left(-35 \begin{smallmatrix} +5 \\ -2,5 \end{smallmatrix} \right) ^\circ\text{C}$$

$$(23 \pm 5) ^\circ\text{C}$$

$$\left(85 \begin{smallmatrix} +2,5 \\ -5 \end{smallmatrix} \right) ^\circ\text{C}$$

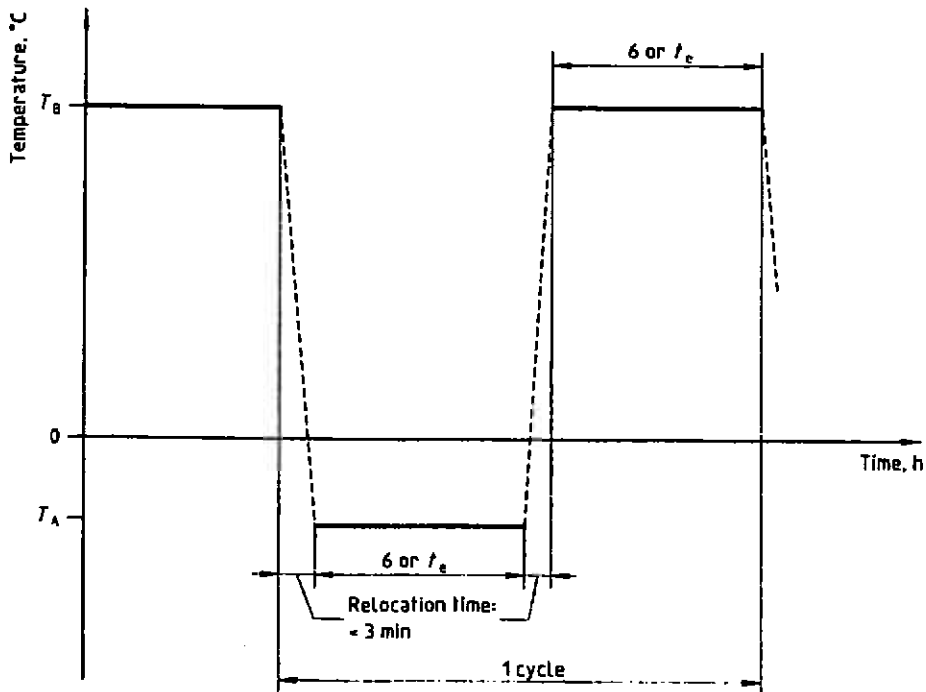

Figure 11 — Cycle of temperature shock test

The airbag module shall be preconditioned until all components are within the required test temperature range. The test may be performed outside the preconditioning chamber provided that temperatures remain within the test temperature range at ignition. The ignition conditions depend on the type of ignition or trigger system in use. During the test, a high-speed camera (at least 1 000 frames/s) shall be used to film the inflation process both from the front and from the side, in order to determine the exact inflation times.

6.1.2 Front passenger airbag module

The airbag module shall be preconditioned until all components are within the required test temperature range. The test may be performed outside the conditioning chamber provided that temperatures remain within the test temperature range at ignition.

Location and cabling of the object to be tested shall correspond to the installed position in the vehicle. Alternatively, the unit may be located in such a way that the airbag unfolds in either the vertical or the horizontal direction.

6.1.3 Requirements

During and after the static deployment test no projected airbag module fragments shall strike a normally seated occupant.

During the static deployment test, the bag surface region which would contact a normally seated occupant shall not tear or burn through. Outside this region, holes of less than 3 mm diameter are allowed. Bag seams shall remain intact.

The inflation time of the unexposed and exposed airbag modules shall be within the defined tolerances, depending on the type of airbag module.

6.2 Tank test

6.2.1 General

The purpose of this test is to compare inflator assembly samples from the modules of the environmental test programme (table 1) with unexposed inflator assembly samples from the modules of the performance test programme (table 2). The performance of an inflator assembly is determined by igniting it in a closed volume container (tank) at a given temperature level.

6.2.2 Equipment

An appropriate tank to test the inflator assemblies shall be used.

6.2.3 Test samples

Two unexposed and two exposed inflator assembly samples, see table 2, shall be tested in the tank.

6.2.4 Test conditions

Each sample shall be preconditioned in a temperature chamber so that the required test temperature given in table 2 is reached. The point of reference for measuring temperature is on the propellant of the inflator assembly.

6.2.5 Test procedure

The inflator assembly shall be fixed tightly to an appropriate tank so that gases and solid particles are captured in the tank during ignition.

If applicable, the inflator assembly shall be ignited with a defined nominal current pulse (amplitude and duration).

Record pressure and time using an appropriate transducer.

6.2.5.1 Measurement of tank pressure

a) Transducer:

Measuring principle: transducer for measuring absolute pressure

Calibration range: shall be appropriate

Usable frequency range: 0 to 2 kHz

Error: linearity and hysteresis $\leq + 1 \%$

b) Measuring and filtering of pressure channel:

CAC: 0 to 500 kPa

CFC: class 1 000 of ISO 6487

Error: $\leq + 2,5 \%$

c) Measuring point:

The pressure probe orifice shall not be in the direct gas flow from the exit ports of the inflator.

6.2.5.2 Measurement of tank temperature

The tank temperature shall be measured at the mounting point of the inflator assembly and shall remain at the ambient temperature.

6.2.5.3 Squib resistance (where applicable)

a) Resistance measurement:

Object: squib with connector.

b) Ignition current supply:

Current impulse depending on the squib type.

c) Measurement of ignition current:

ISO 6487 - CFC 1 000 Hz

- d) Digital filtering:
ISO 8487 - CAC 60m/s² - CFC 100 Hz

6.2.6 Requirements

The pressure versus time curves of the unexposed and exposed inflator assemblies shall correspond to the defined performance diagrams, supplied by the manufacturer for the appropriate type of inflator assembly.

The structural integrity of the inflator shall be maintained.

6.3 Bag test

6.3.1 General

The purpose of this test is to compare bags from the airbag modules of the environmental test programme (table 1) with unexposed bags from the airbag modules of the performance test programme (table 2).

6.3.2 Equipment

Appropriate equipment for textile testing shall be used.

6.3.3 Test samples

Two unexposed samples and two exposed samples, see table 2, shall be tested.

6.3.4 Requirements

The following items shall be within defined tolerances:

- bag volume;
- fabric permeability;
- fabric visual inspection;
- seam strength;
- fabric strength;
- fabric tear strength.

Annex A (normative)

Determination of temperature build-up time t_e

The temperature build-up time t_e is the time required, after a change of the surrounding temperature from T_1 to T_2 , for a defined reference point of the test sample to reach the temperature T_2 .

- within 3 °C, in the case of $|T_2 - T_1| \geq 60$ °C, or
- within 5 % of the absolute value of the temperature difference $(T_2 - T_1)$, in the case of $|T_2 - T_1| < 60$ °C.

The temperature build-up time begins at the point where the desired target value curve reaches the surrounding temperature T_2 (see figures A.1 and A.2). The temperature build-up times shall be determined in the apparatus for the relevant test. The test sample temperature shall be measured at the prescribed reference point.

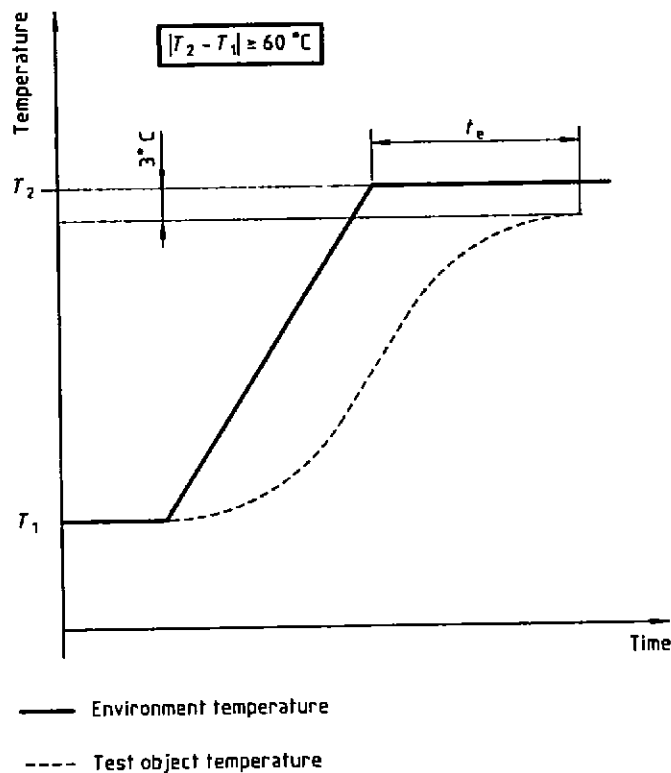

Figure A.1 — Temperature build-up time t_e for $|T_2 - T_1| \geq 60$ °C

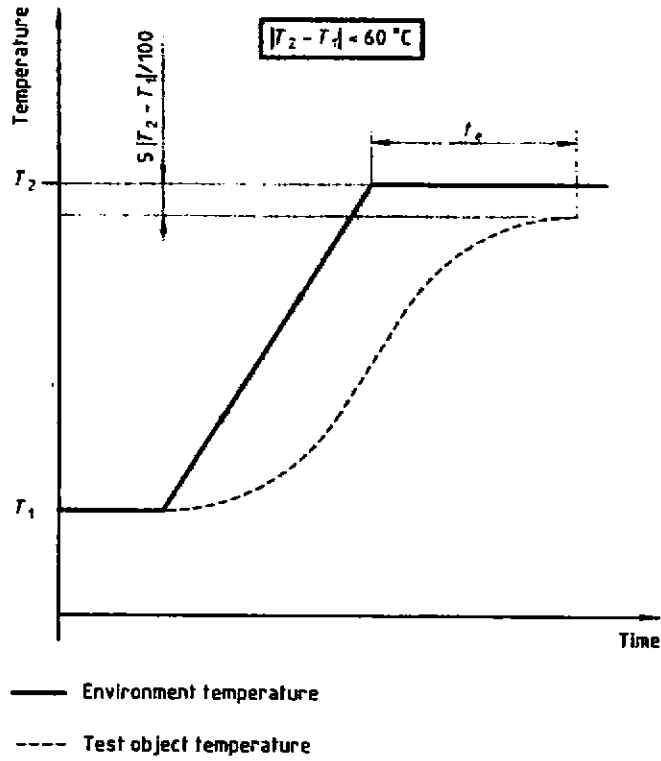

Figure A.2 — Temperature build-up time t_0 for $|T_2 - T_1| < 60 \text{ }^\circ\text{C}$

Annex B
(informative)

Origin of environmental test procedures

| Subclause | Test procedure | Origin |
|------------------|-----------------------------------------|-----------------------|
| 5.1 | Drop test | IEC 68-2-27 |
| 5.2 | Mechanical impact test | IEC 68-2-27 |
| 5.3 | Dust test | UN-ECE R16 (FMVSS209) |
| 5.4 | Simultaneous vibration temperature test | IEC 68-2-53 |
| 5.5 | Thermal humidity cycling test | IEC 68-2-38 |
| 5.6 | Salt spray test | IEC 68-2-52 |
| 5.7 | Solar radiation simulation test | DIN 75 220 |
| 5.8 | Temperature shock test | IEC 68-2-53 |

Annex C (informative)

Bibliography

- [1] IEC 68-2-27:1987, *Basic environmental testing procedures — Part 2: Tests — Test Ea and guidance: Shock.*
- [2] IEC 68-2-38:1974, *Basic environmental testing procedures — Part 2: Tests — Test Z/AD: Composite temperature/humidity cyclic test.*
- [3] IEC 68-2-52:1984, *Basic environmental testing procedures — Part 2: Tests — Test Kb: Salt mist, cyclic (sodium chloride solution).*
- [4] IEC 68-2-53:1984, *Basic environmental testing procedures — Part 2: Tests — Guidance to Tests Z/AFc and Z/BFc: Combined temperature (cold and dry heat) and vibration (sinusoidal) tests.*
- [5] DIN 75220:1992, *Alterung von Kfz-Bauteilen in Sonnensimulationsanlagen.*
- [6] UN-ECE, Regulation No. 16, *Uniform provisions concerning the approval of safety belts and restraint systems for adult occupants of power driven vehicles.*

ICS 43.040.60

Descriptors: road vehicles, safety devices, air bags (vehicle safety), modules, tests, environmental tests, performance tests, testing conditions.

Price based on 20 pages
