

---

---

**Lasers and laser-related equipment —  
Determination of laser resistance of  
tracheal tubes —**

**Part 1:  
Tracheal tube shaft**

*Lasers et équipements associés aux lasers — Détermination de la  
résistance au laser des tubes trachéaux —*

*Partie 1: Axe des tubes trachéaux*





**COPYRIGHT PROTECTED DOCUMENT**

© ISO 2011

All rights reserved. Unless otherwise specified, no part of this publication may be reproduced or utilized in any form or by any means, electronic or mechanical, including photocopying and microfilm, without permission in writing from either ISO at the address below or ISO's member body in the country of the requester.

ISO copyright office  
Case postale 56 • CH-1211 Geneva 20  
Tel. + 41 22 749 01 11  
Fax + 41 22 749 09 47  
E-mail [copyright@iso.org](mailto:copyright@iso.org)  
Web [www.iso.org](http://www.iso.org)

Published in Switzerland

**Contents**

Page

<b>Foreword</b> .....	<b>iv</b>
<b>Introduction</b> .....	<b>v</b>
<b>1 Scope</b> .....	<b>1</b>
<b>2 Normative references</b> .....	<b>1</b>
<b>3 Terms and definitions</b> .....	<b>1</b>
<b>4 Principle</b> .....	<b>2</b>
<b>5 Significance and use of the test</b> .....	<b>3</b>
<b>6 Apparatus</b> .....	<b>3</b>
<b>6.1 Gas supply system</b> .....	<b>3</b>
<b>6.2 Containment box</b> .....	<b>4</b>
<b>6.3 Smoke evacuation</b> .....	<b>5</b>
<b>6.4 Lasers and delivery systems</b> .....	<b>5</b>
<b>6.5 Oxygen analyser</b> .....	<b>6</b>
<b>7 Reagents and materials</b> .....	<b>6</b>
<b>8 Preparation of test specimen</b> .....	<b>6</b>
<b>9 Preparation of apparatus</b> .....	<b>6</b>
<b>10 Test procedure</b> .....	<b>7</b>
<b>11 Interpretation of results</b> .....	<b>8</b>
<b>12 Test report</b> .....	<b>8</b>
<b>Bibliography</b> .....	<b>10</b>

## Foreword

ISO (the International Organization for Standardization) is a worldwide federation of national standards bodies (ISO member bodies). The work of preparing International Standards is normally carried out through ISO technical committees. Each member body interested in a subject for which a technical committee has been established has the right to be represented on that committee. International organizations, governmental and non-governmental, in liaison with ISO, also take part in the work. ISO collaborates closely with the International Electrotechnical Commission (IEC) on all matters of electrotechnical standardization.

International Standards are drafted in accordance with the rules given in the ISO/IEC Directives, Part 2.

The main task of technical committees is to prepare International Standards. Draft International Standards adopted by the technical committees are circulated to the member bodies for voting. Publication as an International Standard requires approval by at least 75 % of the member bodies casting a vote.

Attention is drawn to the possibility that some of the elements of this document may be the subject of patent rights. ISO shall not be held responsible for identifying any or all such patent rights.

ISO 11990-1 was prepared by Technical Committee ISO/TC 172, *Optics and photonics*, Subcommittee SC 9, *Electro-optical systems*.

This first edition of ISO 11990-1 cancels and replaces ISO 11990:2003, of which it constitutes a minor revision.

ISO 11990 consists of the following parts, under the general title *Lasers and laser-related equipment — Determination of laser resistance of tracheal tubes*:

- *Part 1: Tracheal tube shaft*
- *Part 2: Tracheal tube cuffs*

## Introduction

A fire in the airway is always a serious matter. In addition to local damage in the larynx, injury can occur to the lower airway and the parenchymal tissue in the lung. The products of combustion can be blown into the lungs.

Procedures performed in the airway where a tracheal tube and a laser are used bring together an oxygen-enriched atmosphere, a fuel and high power, the three ingredients necessary to create a fire. The likelihood that a laser beam will contact the tracheal tube during airway procedures is high.

In the early to mid-1980s, the increasing use of such lasers was followed by airway fires and, subsequently, the development of tracheal tubes designed specifically to be resistant to laser ignition and damage. Unfortunately, some of these tubes were not sufficiently resistant under operating room conditions, and airway fires continued to occur. These events led to the development of the test method described in this part of ISO 11990, in order to assist the clinician in determining which tracheal tube shaft is most laser-resistant for a defined set of conditions.



# Lasers and laser-related equipment — Determination of laser resistance of tracheal tubes —

## Part 1: Tracheal tube shaft

### 1 Scope

This part of ISO 11990 specifies a method of testing the continuous wave (cw) resistance of the shaft of a tracheal tube designed to resist ignition by a laser. It is not applicable to other components of the system, such as the inflation system and cuff, which are defined in ISO 11990-2 (see Note 1).

NOTE 1 ISO 11990-2 specifies the method for testing the laser resistance of the tracheal tube cuff.

This part of ISO 11990 can be used to measure and describe the properties of materials, products or assemblies in response to heat and flame under controlled laboratory conditions. It does not describe or appraise the fire hazard or fire risk of materials, products, or assemblies under actual clinical use conditions. However, the results of this test can be used as one element of a fire risk assessment which takes into account all factors pertinent to an assessment of the hazard of a particular end use.

NOTE 2 The direct applicability of the result of this test method to the clinical situation has not been fully established.

**CAUTION — This test method can involve hazardous materials, operations, and equipment. This part of ISO 11990 provides advice on minimizing some of the risks associated with its use but does not purport to address all such risks. It is the responsibility of the user of this part of ISO 11990 to establish appropriate safety and health practices and to determine the applicability of regulatory limitations prior to use.**

### 2 Normative references

The following referenced documents are indispensable for the application of this document. For dated references, only the edition cited applies. For undated references, the latest edition of the referenced document (including any amendments) applies.

ISO 11146-1, *Lasers and laser-related equipment — Test methods for laser beam widths, divergence angles and beam propagation ratios — Part 1: Stigmatic and simple astigmatic beams*

### 3 Terms and definitions

For the purposes of this document, the following terms and definitions apply.

#### 3.1

##### beam cross-sectional area

$A_{95}$

smallest area containing 95 % of the total beam power

[ISO 11990-2:2010]

**3.2**  
**beam diameter**

$d_{95}$   
diameter of an aperture in a plane perpendicular to the beam axis which contains 95 % of the total beam power

NOTE Adapted from ISO 11145.

[ISO 11990-2:2010]

**3.3**  
**combustion**

any continuing burning process that occurs in or on the test specimen caused by a chemical process of oxidation with the liberation of heat

EXAMPLES Flame, smouldering, rapid evolution of smoke.

[ISO 11990-2:2010]

**3.4**  
**damage**

any change, other than combustion, which may affect the safety of the patient or efficacy of the tracheal tube due to increasing the risk of ignition

EXAMPLES Local heating, melting, creation of holes, pyrolysis.

[ISO 11990-2:2010]

**3.5**  
**ignition**

creation of combustion induced by the delivery of power

[ISO 11990-2:2010]

**3.6**  
**laser resistance**

measure of the ability of a material to withstand laser power without ignition or damage

[ISO 11990-2:2010]

**3.7**  
**shaft**

portion of the tracheal tube between the cuff and the machine end of the tube

## 4 Principle

**WARNING — This test method can result in a rocket-like fire involving the tracheal tube. Such a fire can produce intense heat and light and toxic gases.**

To simulate worst-case conditions, the shaft of a tracheal tube is exposed to laser power of known characteristics while in an environment of  $(98 \pm 2)$  % oxygen.



## 5 Significance and use of the test

**5.1** This part of ISO 11990 describes a uniform and repeatable test method for measuring the laser resistance of the shaft of a tracheal tube. Most of the variables involved in laser ignition of a tracheal tube have been fixed in order to establish a basis for comparison. This test method for measuring can be used to compare tracheal tubes having differing types and designs of laser protection.

**5.2** A large number and range of variables are involved in ignition of a tracheal tube. A change in one variable can affect the outcome of the test. Caution should be observed, since the direct applicability of the results of this test method to the clinical situation has not been fully established.

NOTE This method can be applied to study the effect of changing the test conditions, but this is outside the scope of this part of ISO 11990. For example, variation of the breathing-gas flow rate or different breathing-gas mixtures might affect the laser resistance of the shaft of a tracheal tube.

**5.3** Since an oxygen-enriched atmosphere is often present in the clinical situation, either intentionally or unintentionally, the test is performed in an environment of  $(98 \pm 2)$  % oxygen.

**5.4** A flow rate of 1 l/min of oxygen in a 6,0 mm inner diameter tube was chosen as the most appropriate conditions for shaft ignition and establishment of a fire, based on the work cited in Reference [8].

**5.5** The preparation of the shaft of the test specimen shall be in accordance with the manufacturer's instructions for use.

**5.6** Use of beam cross-sectional shape other than circular, or mode of laser power delivery other than continuous wave can affect the shaft ignition characteristics. Also, shafts of different construction have different laser resistances (see References [8] to [14]).

## 6 Apparatus

### 6.1 Gas supply system

**6.1.1** The gas supply system shall provide oxygen to the tracheal tube at a controllable flow rate. Also, the system shall be capable of rapidly flooding the containment box with nitrogen or other inert gas or stopping oxygen flow, or both, to extinguish any burning material. An oxygen flow meter and controller and a quick-action inert gas valve shall be part of this system (see Figure 1). The nitrogen or inert gas supplied shall be at a higher pressure and allow a flow rate of at least an order of magnitude greater than that of the oxygen supplied to the tracheal tube.

**6.1.2** Other arrangements, such as an oxygen flood valve for rapidly purging the containment box or an inert gas flooding system for rapid extinguishment of burning material, may be used as long as the requirements of the test method as defined herein are not affected.

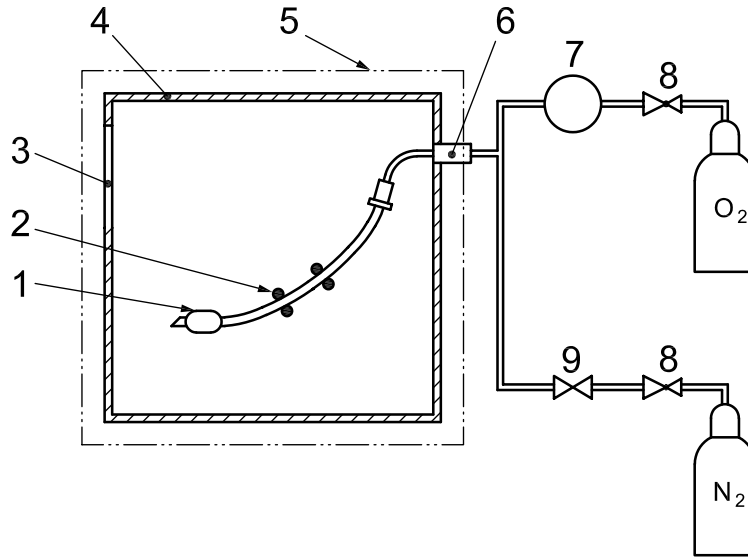

**Key**

- 1 test tracheal tube
- 2 tracheal tube support using two clamps
- 3 opening for laser access
- 4 containment box (lateral view)
- 5 enclosure cover (may be multi-piece)
- 6 flashback arrestor
- 7 oxygen flow meter and controller
- 8 pressure regulator with inlet and outlet gauges
- 9 quick-action inert gas valve

**Figure 1 — Typical testing apparatus schematic**

**6.2 Containment box**

**6.2.1** The containment box controls the environment around the test specimen while allowing the laser beam to be directed onto the test specimen.

**6.2.2** The containment box shall have the following characteristics.

- a) It allows direct access of the laser beam to the entire length of the tracheal tube shaft.
- b) It allows the mounting of the test specimen.
- c) It maintains an environment of  $(98 \pm 2)$  % oxygen around the tracheal tube.
- d) It exhausts the gas flowing through the tube and any products of combustion to a safe area.
- e) It is fireproof and easily cleaned of soot and residue from burned tracheal tubes.
- f) It is rectangular in shape and measures approximately 46 cm × 46 cm × 46 cm.
- g) While maintaining the test environment of  $(98 \pm 2)$  % oxygen, it has openings closed with transparent, non-flammable covers, or windows, to allow:
  - 1) observation with video cameras on the top and on all sides of the box; a minimum of three video cameras (one camera positioned above the containment box and two cameras positioned on two sides of the containment box) is needed for recording purposes;

- 2) access to the test specimen;
- 3) cleaning of the box, and cleaning of the covers and/or windows themselves.

The opening to allow laser access to the test specimen shall be positioned such that the laser beam can be directed perpendicular to the surface of the shaft. A door, or at least one cover or window, shall allow access to the test specimen.

- h) It can be rapidly flooded with nitrogen or another inert gas to extinguish any fire inside the box.
- i) The top is covered with appropriate filter media to protect the sample and the interior of the box from reflections.

**6.2.3** Other configurations may be used, as long as the requirements of the test method as defined herein are not affected.

### 6.3 Smoke evacuation

**WARNING — Combustion of most materials used in tracheal tubes produces toxic gases such as carbon monoxide, hydrogen chloride and hydrogen cyanide. Also, the smoke produced in such fires contains hazardous particles of carbon, silica, unburned matter and other materials.**

**6.3.1** A device shall be attached to the containment box to safely remove smoke resulting from a burning tracheal tube, but it shall be designed to minimize the chance of drawing fire into the exhaust system. Placing the containment box in a fume hood that exhausts to a safe location satisfies this requirement.

**6.3.2** The smoke evacuation device shall not interfere with maintaining the oxygen environment within the containment box. For example, the flow of a fume hood should not create draughts that would enter or pull gas from the opening for laser access. A smoke evacuation should not be activated until after the initiation of combustion.

### 6.4 Lasers and delivery systems

**WARNING — Surgical lasers emit radiation of sufficient power to damage living tissue or ignite fires directly or by reflection of radiation. In addition to other precautions, test personnel should be trained in the use of lasers and take proper safety measures based on the type of laser being used. These precautions should include laser-safety eyewear, protective clothing and controlled access to the test area.**

**6.4.1** Various laser types emitting radiation of wavelengths in the visible and infrared ranges are used during ENT (ear, nose and throat) surgery. Any laser that meets the requirements listed in this test procedure is suitable for use in this test.

**6.4.2** The continuous wave laser radiation shall be applied with the same optical quality as is typically used for a surgical procedure. These devices allow a laser beam with known and controllable size to be directed onto an area of treatment without physical contact. The system shall provide a beam diameter,  $d_{95}$ , of  $0,5 \text{ mm} \pm 10 \%$  at the surface of the test specimen in accordance with ISO 11146-1.

**NOTE** Bare fibres, contact tips, contact fibres or other devices that convert some laser power into heat and are used in physical contact with tissue are not covered by this test method. Heat affects materials differently from laser power and is inconsistent with this test method.

**CAUTION — Cooling or clearing gases shall not be used. Cooling or clearing gases are used by some lasers to maintain the quality of the delivery system. The flow of these gases can alter the measured laser resistance, e.g. by extinguishing nascent fire.**

**6.4.3** The power of radiation transmitted by these systems should be verified as being accurate to  $\pm 10 \%$ . This can be accomplished by the use of an external power meter or internal calibration systems.

## 6.5 Oxygen analyser

**6.5.1** Any device that can measure the concentration of gaseous oxygen with a repeatability of at least 1 % of full scale and a calibrated accuracy of at least 1 % of full scale is satisfactory.

**6.5.2** The oxygen sensor shall be positioned so as to minimize the chance of its ignition by any fire in the containment box.

## 7 Reagents and materials

**7.1** **Oxygen**,  $(98 \pm 2)$  % (volume fraction) pure.

**7.2** **Nitrogen or other inert gas** (i.e. non-oxidizing, non-flammable),  $(98 \pm 2)$  % (volume fraction) pure.

## 8 Preparation of test specimen

**8.1** The test specimen shall be any material, device or system used as a tracheal tube, with whatever modifications used to protect the tracheal tube from laser power.

**8.2** Five test specimens shall be used.

**8.3** Each test specimen shall be prepared according to the manufacturer's instructions for use. Some devices might require special preparation (e.g. wetting of tube, filling cuff with isotonic saline or water, insufflation with inert gas).

**8.4** The test specimens shall be free from extraneous materials, as such materials can significantly alter the laser resistance of the tracheal tube.

EXAMPLES Char, ash, soot, blood, mucous, lubricants and other materials.

**8.5** The test specimen and apparatus shall be equilibrated to  $(20 \pm 3)$  °C in an oxygen-enriched  $(98 \pm 2)$  % atmosphere for 10 min prior to the start of testing.

NOTE 1 This is done to standardize the test conditions rather than to simulate a clinical condition. The ignitability and flammability of most materials do not significantly change between room temperature and body temperature. However, some polymers do change their oxygen absorption, and therefore their flammability, with temperature.

NOTE 2 Some materials, such as polymers, absorb oxygen and can have diminished laser resistance if exposed to oxygen for long periods of time.

## 9 Preparation of apparatus

**9.1** Ensure that the containment box is clean (i.e. free of contaminants). The enclosure covers should be clear and clean enough to allow test personnel to view laser interaction with the test specimen by observation with video cameras.

NOTE Contamination can interfere with the performance of the test or evaluation of the results.

**9.2** Ensure that the laser is in working order, that its operation is understood, and that personnel protection is in place.

**9.3** Ensure that there is adequate oxygen for the test and nitrogen, or other gas, for extinguishing any resulting fire.

**9.4** Have other means of fire extinguishment (e.g. a carbon dioxide fire extinguisher) at hand. Water is not recommended, as it will not extinguish some materials burning in oxygen and, if used, will cause considerable soiling of the containment box and will interfere with interpretation of the results of laser interaction with the test specimen. Water is not recommended for use on fire involving energized electrical equipment.

## 10 Test procedure

**10.1** Perform the test at  $(20 \pm 3) ^\circ\text{C}$ .

**10.2** Insert the test specimen in the containment box. Connect the gas supply system to the apparatus.

**10.3** Place the enclosure cover on the top of the containment box, as shown in Figure 1. Ensure that the opening for laser access is as small as possible, in order to maintain the oxygen-enriched atmosphere while still allowing laser access to the shaft of the test specimen. Also, ensure that the test specimen is visible through the enclosure cover.

**10.4** Ensure that the inert gas flush is working properly.

**10.5** Ensure that the smoke evacuation system is working properly and will not affect the gas concentration in the containment box during the test.

**10.6** Flow oxygen into the containment box at a rate and time period sufficient to establish an environment of  $(98 \pm 2) \%$  oxygen. This oxygen level shall be verified by use of an oxygen analyser (see 6.5) measuring the environment.

**10.7** Establish an oxygen flow rate of 1 l/min through the test specimen.

**10.8** Position the laser so that

- the laser beam is perpendicular to the surface of the shaft of the test specimen (see Figure 2);
- the beam diameter,  $d_{95}$ , measured in accordance with ISO 11146-1, shall be  $0,5 \text{ mm} \pm 10 \%$  at the surface of the test specimen (the beam cross-sectional area,  $A_{95}$ , is a critical dimension).

Lateral motion of the laser spot shall be minimized by some form of stabilization.

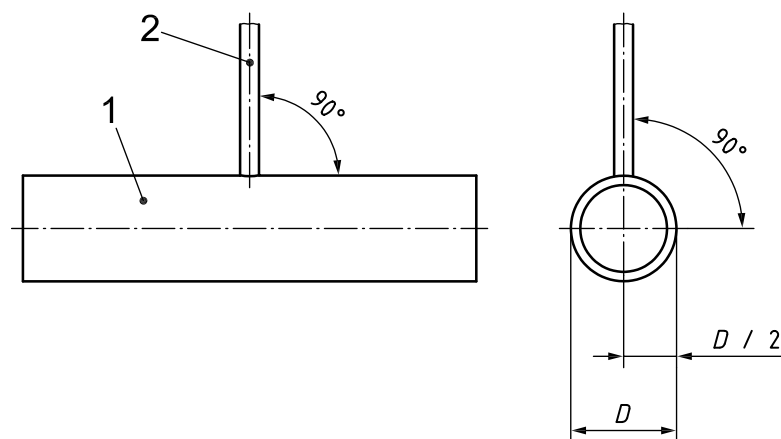

### Key

- 1 test shaft
- 2 laser beam

**Figure 2 — Laser beam firing angle**

**10.9** Verify that the following standardised test parameters are correct during performance of the test:

- a) exact positioning of the laser beam;
- b) oxygen concentration:  $(98 \pm 2) \%$ ;
- c) temperature  $(20 \pm 3) ^\circ\text{C}$ ;
- d) oxygen flow rate: 1 l/min;
- e) laser beam diameter  $d_{95}$ :  $0,5 \text{ mm} \pm 10 \%$ ;
- f) mode of laser operation: continuous wave.

**10.10** Starting with a power of 2 W, apply the laser beam to the test specimen for a specified duration of 1 s up to 10 s maximum, using the continuous wave mode of laser operation. Stop the laser beam if ignition, or damage (i.e. melting, perforation, leakage, etc.) occurs or if there is difficulty with the test apparatus. These data shall be reported in addition to data collected at 10 s.

**10.11** Increase the laser power in reasonable steps. Repeat the application of the laser beam for each new power level or until ignition or damage occurs as described in 10.10. This shall necessitate either the use of a new specimen or, if the construction of the shaft is identical around the whole circumference, rotation of the specimen (at a cool, clean undamaged area) for each new power level to determine the maximum power setting at which ignition or damage did not occur. Once the maximum power setting has been determined, verify the maximum power setting by beginning the testing procedure with the five specimens according to 8.2.

## **11 Interpretation of results**

**11.1** Any test specimen that experiences ignition as defined in 3.5 is considered to have laser resistance up to the maximum power at which the ignition did not occur under the specified test conditions.

**11.2** Any damage (see 3.4) to the test specimen (e.g. melting, creation of holes) shall be described in the test report, together with the laser settings that caused such change(s).

## **12 Test report**

The test report shall include the following information for each test specimen:

- a) laser type, nominal wavelength and delivery system used;
- b) laser power duration, expressed in seconds;
- c) maximum power, expressed in watts, of the laser;
- d) outside diameter, expressed in millimetres, of the test specimen;
- e) manufacturer of tracheal tube and identifying data, material of the shaft;
- f) whether the shaft material is laser-resistant or not;
- g) length, expressed in centimetres, of the test specimen;
- h) a description of any ignition or damage;
- i) power, expressed in watts, at which ignition or damage of the shaft occurred;

- j) maximum power, expressed in watts, that did not cause ignition or damage of the shaft;
- k) physical description (colour, size) of the flame or damage produced;
- l) location where ignition or damage of the shaft occurred;
- m) statement that the test has been performed in accordance with this part of ISO 11990;
- n) date and time of test;
- o) name and address of the test organization;
- p) name and signature of the individual performing the test;
- q) graphical report of results, showing power against laser exposure duration;
- r) report of results.

## Bibliography

- [1] ISO 5361, *Anaesthetic and respiratory equipment — Tracheal tubes and connectors*
- [2] ISO 11145, *Optics and photonics — Lasers and laser-related equipment — Vocabulary and symbols*
- [3] ISO 11990-2:2010, *Lasers and laser-related equipment — Determination of laser resistance of tracheal tubes — Part 2: Tracheal tube cuffs*
- [4] ISO/TR 11991, *Guidance on airway management during laser surgery of upper airway*
- [5] ISO 14408, *Tracheal tubes designed for laser surgery — Requirements for marking and accompanying information*
- [6] IEC 60601-2-22, *Medical electrical equipment — Part 2-22: Particular requirements for basic safety and essential performance of surgical, cosmetic, therapeutic and diagnostic laser equipment*
- [7] IEC 60825-1, *Safety of laser products — Part 1: Equipment classification and requirements*
- [8] SIDEBOTHAM, G.W., WOLF, G.L., *et al.* Endotracheal Tube Fire: A Flame Spread Phenomenon, in STOLTZFUS, J., and McILROY, K. eds., ASTM STP 1111 *Flammability and Sensitivity of Materials in Oxygen-Enriched Atmospheres*, 5, pp. 168-178, May 1991
- [9] ECRI, Evaluation of Laser Resistant Endotracheal Tubes, *Health Devices*, **19**, (4), pp. 123-134, 1990
- [10] OSSOFF, R.H., Laser Safety in Otolaryngology — Head and Neck Surgery: Anesthetic and Educational Considerations for Laryngeal Surgery, *Laryngoscope*, Supplement, **48**, (99), pp. 1-26, 1989
- [11] PASHAYAN, A.G. and GRAVENSTEIN, J.S., Helium Retards Endotracheal Tube Fires from Carbon Dioxide Lasers, *Anesthesiology*, **62**, (3), pp. 274-277, 1985
- [12] SOSIS, M.B., Anesthesia for laser surgery, *Problems in anesthesia*, Vol. 7, Lippincott, Philadelphia PA, 1993
- [13] FOTH, H.-J., Laser resistance of endotracheal tubes I: Experimental results of a compound tube in comparison to a metallic tube, *Lasers Med Sci*, **13**:242-252, 1998
- [14] FOTH, H.-J., Laser resistance of endotracheal tubes II: Observed temperature rise and theoretical explanation, *Lasers Med Sci*, **14**, pp. 24-31, 1999
- [15] BERLIEN, H.-P., *The Cuff — The weak point for ignition safety of endotracheal tubes*, ILSC, San Francisco, International Laser Safety Conference proceedings, 2005





