**Petroleum and natural gas industries —
Steel drill pipe**

Industries du pétrole et du gaz naturel — Tiges de forage en acier



PDF disclaimer

This PDF file may contain embedded typefaces. In accordance with Adobe's licensing policy, this file may be printed or viewed but shall not be edited unless the typefaces which are embedded are licensed to and installed on the computer performing the editing. In downloading this file, parties accept therein the responsibility of not infringing Adobe's licensing policy. The ISO Central Secretariat accepts no liability in this area.

Adobe is a trademark of Adobe Systems Incorporated.

Details of the software products used to create this PDF file can be found in the General Info relative to the file; the PDF-creation parameters were optimized for printing. Every care has been taken to ensure that the file is suitable for use by ISO member bodies. In the unlikely event that a problem relating to it is found, please inform the Central Secretariat at the address given below.



COPYRIGHT PROTECTED DOCUMENT

© ISO 2008

All rights reserved. Unless otherwise specified, no part of this publication may be reproduced or utilized in any form or by any means, electronic or mechanical, including photocopying and microfilm, without permission in writing from either ISO at the address below or ISO's member body in the country of the requester.

ISO copyright office
Case postale 56 • CH-1211 Geneva 20
Tel. + 41 22 749 01 11
Fax + 41 22 749 09 47
E-mail copyright@iso.org
Web www.iso.org

Published in Switzerland

Contents

Page

Foreword.....	v
Introduction	vi
1 Scope	1
2 Conformance	1
2.1 Dual citing of normative references.....	1
2.2 Units of measurement	2
3 Normative references	2
4 Terms, definitions, symbols and abbreviated terms.....	4
4.1 Terms and definitions.....	4
4.2 Symbols and abbreviated terms	8
5 Information to be supplied when placing orders for drill-pipe	10
6 Requirements for drill-pipe.....	11
6.1 General.....	11
6.2 Dimensions, masses and connections.....	11
6.3 Material requirements.....	12
6.4 Process of manufacture for drill-pipe.....	14
6.5 Traceability	15
6.6 Inspection and testing — General.....	15
6.7 Testing of welds	16
6.8 Tensile test	16
6.9 Hardness test	17
6.10 Charpy V-notch impact test.....	18
6.11 Transverse side-bend test	19
6.12 Imperfections and defects in drill-pipe.....	19
6.13 Visual inspection of the drill-pipe weld zone.....	20
6.14 Non-destructive examination of the weld zone	20
6.15 Marking of drill-pipe.....	22
6.16 Minimum facility requirements for drill-pipe manufacturers	23
6.17 Documentation requirements of drill-pipe	24
7 Requirements for drill-pipe body	24
7.1 Information to be supplied when placing orders for drill-pipe bodies.....	24
7.2 Dimensional and mass requirements	25
7.3 Material requirements.....	27
7.4 Process of manufacture	28
7.5 Traceability	28
7.6 Inspection and testing — General.....	29
7.7 Testing of chemical composition.....	29
7.8 Tensile tests	30
7.9 Charpy V-notch impact tests	31
7.10 Drill-pipe-body wall thickness	32
7.11 Drill-pipe-body length.....	32
7.12 Internal upset	32
7.13 Internal profile	32
7.14 Straightness	33
7.15 Upset alignment.....	33
7.16 Mass determination	33
7.17 Imperfections and defects of drill-pipe body.....	33
7.18 Visual inspection of drill-pipe body.....	34

7.19	Non-destructive examination	34
7.20	Marking.....	38
7.21	Minimum facility requirements for drill-pipe-body manufacturer	39
7.22	Documentation requirements	39
8	Requirements for tool joints	40
8.1	Information to be supplied when placing orders for tool joints.....	40
8.2	Dimensional requirements	41
8.3	Material requirements	41
8.4	Process of manufacture	42
8.5	Traceability	43
8.6	Inspection and testing — General	43
8.7	Testing of chemical composition	43
8.8	Tensile tests.....	44
8.9	Hardness tests.....	45
8.10	Charpy V-notch impact tests	45
8.11	Imperfections and defects.....	47
8.12	Non-destructive examination.....	47
8.13	Marking.....	48
8.14	Minimum facility requirements for tool-joint manufacturers.....	48
8.15	Documentation requirements for tool joints	49
Annex A (normative) Tables in SI units.....		51
Annex B (normative) Figures in SI (USC) units		69
Annex C (normative) Tables in USC units		83
Annex D (normative) Purchaser inspection.....		101
Annex E (informative) Supplementary requirements.....		102
Annex F (informative) Procedures used to convert from USC units to SI units for drill-pipe		105
Annex G (normative) Product specification levels		109
Annex H (informative) API monogram		111
Bibliography		112

Foreword

ISO (the International Organization for Standardization) is a worldwide federation of national standards bodies (ISO member bodies). The work of preparing International Standards is normally carried out through ISO technical committees. Each member body interested in a subject for which a technical committee has been established has the right to be represented on that committee. International organizations, governmental and non-governmental, in liaison with ISO, also take part in the work. ISO collaborates closely with the International Electrotechnical Commission (IEC) on all matters of electrotechnical standardization.

International Standards are drafted in accordance with the rules given in the ISO/IEC Directives, Part 2.

The main task of technical committees is to prepare International Standards. Draft International Standards adopted by the technical committees are circulated to the member bodies for voting. Publication as an International Standard requires approval by at least 75 % of the member bodies casting a vote.

Attention is drawn to the possibility that some of the elements of this document may be the subject of patent rights. ISO shall not be held responsible for identifying any or all such patent rights.

ISO 11961 was prepared by Technical Committee ISO/TC 67, *Materials, equipment and offshore structures for petroleum, petrochemical and natural gas industries*, Subcommittee SC 5, *Casing, tubing and drill pipe*.

This second edition cancels and replaces the first edition (ISO 11961:1996), which has been extensively technically revised.

It is the intention of ISO/TC 67 that either this edition or the previous edition of ISO 11961 be applicable, at the option of the purchaser (as defined in 4.1.31), for a period of six months from the first day of the calendar quarter immediately following the date of publication of this edition, after which period the previous edition will no longer be applicable.

Introduction

This International Standard is based on API Spec 5D and API Spec 7.

Users of this International Standard should be aware that further or differing requirements may be needed for individual applications. This International Standard is not intended to inhibit a vendor from offering, or the purchaser from accepting, alternative equipment or engineering solutions for the individual application. This may be particularly applicable where there is innovative or developing technology. Where an alternative is offered, the vendor should identify any variations from this International Standard and provide details.

This International Standard includes provisions of various natures. These are identified by the use of certain verbal forms:

- a) SHALL is used to indicate that a provision is MANDATORY;
- b) SHOULD is used to indicate that a provision is not mandatory, but RECOMMENDED as good practice;
- c) MAY is used to indicate that a provision is OPTIONAL.

Petroleum and natural gas industries — Steel drill pipe

1 Scope

This International Standard specifies the technical delivery conditions for steel drill-pipes with upset pipe-body ends and weld-on tool joints for use in drilling and production operations in petroleum and natural gas industries for three product specification levels (PSL-1, PSL-2 and PSL-3). The requirements for PSL-1 form the basis of this International Standard. The requirements that define different levels of standard technical requirements for PSL-2 and PSL-3 are in Annex G.

This International Standard covers the following grades of drill-pipe:

- grade E drill-pipe;
- high-strength grades of drill-pipe, grades X, G and S.

A typical drill-pipe configuration is given, showing main elements and lengths (see Figure B.1). The main dimensions and masses of the grades of drill-pipe are given in both SI units (see Table A.1) and in USC units (see Table C.1).

This International Standard can also be used for drill-pipe with tool joints not specified by ISO or API standards.

By agreement between purchaser and manufacturer, this International Standard can also be applied to other drill-pipe body and/or tool-joint dimensions. This International Standard lists supplementary requirements that can optionally be agreed between purchaser and manufacturer, for testing, performance verification and non-destructive examination (see Annex E).

This International Standard does not consider performance properties.

NOTE 1 In this International Standard, drill-pipe is designated by label 1, label 2, grade of material (E, X, G and S), upset type and type of rotary shouldered connection. Designations are used for the purpose of identification in ordering.

NOTE 2 Reference can be made to ISO 10424-2 or API Spec 7-2 for the detailed requirements for the threading of drill-pipe tool joints.

NOTE 3 Reference can be made to API RP 7G for the performance properties of the drill-pipe.

2 Conformance

2.1 Dual citing of normative references

In the interests of world-wide application of this International Standard, Technical Committee ISO/TC 67 has decided, after detailed technical analysis, that certain of the normative documents listed in Clause 3 and prepared by ISO/TC 67 or another ISO Technical Committee are interchangeable in the context of the relevant requirement with the relevant document prepared by the American Petroleum Institute (API), the American Society for Testing and Materials (ASTM) and the American National Standards Institute (ANSI). These latter documents are cited in the running text following the ISO reference and preceded by “or”, for example “ISO XXXX or API YYYY”. Application of an alternative normative document cited in this manner will lead to technical results different from the use of the preceding ISO reference. However, both results are acceptable and these documents are thus considered interchangeable in practice.

2.2 Units of measurement

In this International Standard, data are expressed in both the International System (SI) of units and the United States Customary (USC) system of units. Separate tables for data expressed in SI units and USC units are in Annex A and Annex C, respectively. Figures are in Annex B and express data in both SI and USC units. For a specific order item, it is intended that only one system of units be used, without combining data expressed in the other system.

Products manufactured to specifications expressed in either of these unit systems shall be considered equivalent and totally interchangeable. Consequently, compliance with the requirements of this International Standard as expressed in one system provides compliance with requirements expressed in the other system.

For data expressed in the SI system, a comma is used as the decimal separator and a space as the thousands separator. For data expressed in the USC system, a dot (on the line) is used as the decimal separator and a space as the thousands separator.

In the text, data in SI units are followed by data in USC units in brackets.

NOTE The procedures used to convert from USC units to SI units are given in informative Annex F.

3 Normative references

The following referenced documents are indispensable for the application of this document. For dated references, only the edition cited applies. For undated references, the latest edition of the referenced document (including any amendment) applies.

ISO 6506-1, *Metallic materials — Brinell Hardness test — Part 1: Test method*

ISO 6507-1, *Metallic materials — Vickers hardness test — Part 1: Test method*

ISO 6508-1, *Metallic materials — Rockwell hardness test — Part 1: Test method (scales A, B, C, D, E, F, G, H, K, N, T)*

ISO 6892, *Metallic materials — Tensile testing*

ISO 7500-1, *Metallic materials — Verification of static uni-axial testing machines — Part 1: Tension/compression testing machines — Verification and calibration of the force-measuring system*

ISO 9303, *Seamless and welded (except submerged arc-welded) steel tubes for pressure purposes — Full peripheral ultrasonic testing for the detection of longitudinal imperfections*

ISO 9304, *Seamless and welded (except submerged arc-welded) steel tubes for pressure purposes — Eddy current testing for the detection of imperfections*

ISO 9305, *Seamless steel tubes for pressure purposes — Full peripheral ultrasonic testing for the detection of transverse imperfections*

ISO 9402, *Seamless and welded (except submerged arc-welded) steel tubes for pressure purposes — Full peripheral magnetic transducer/flux leakage testing of ferromagnetic steel tubes for the detection of longitudinal imperfections*

ISO 9513, *Metallic materials — Calibration of extensometers used in uniaxial testing*

ISO 9598, *Seamless steel tubes for pressure purposes — Full peripheral magnetic transducer/flux leakage testing of ferromagnetic steel tubes for the detection of transverse imperfections*

ISO/TR 9769, *Steel and iron — Review of available methods of analysis*

ISO/TR 10400, *Petroleum and natural gas industries — Equations and calculations for the properties of casing, tubing, drill-pipe and line pipe used as casing or tubing*

ISO 10424-2, *Petroleum and natural gas industries — Rotary drilling equipment — Part 2: Threading and gauging of rotary shouldered thread connections*

ISO 11484, *Steel tubes for pressure purposes — Qualification and certification of non-destructive (NDT) personnel*

ISO 13665, *Seamless and welded steel tubes for pressure purposes — Magnetic particle inspection of the tube body for the detection of surface imperfections*

API Spec 7-2, *Specification for Threading and Gauging of Rotary Shouldered Thread Connections*

API RP 7G, *Recommended Practice for Drill Stem Design and Operating Limits*

ANSI/API 5C3, *Bulletin on Formulas and Calculations for Casing, Tubing, Drill-pipe, and Line Pipe Properties (including Supplement 1)*

ASME *Boiler and Pressure Vessel Code, Section IX*

ASNT SNT-TC-1A, *Recommended Practice, Personnel Qualification and Certification in Non-Destructive Testing*

ASTM A370, *Standard Test Methods and Definitions for Mechanical Testing of Steel Products*

ASTM A751, *Standard Test Methods, Practices and Terminology for Chemical Analysis of Steel Products*

ASTM A941, *Terminology Relating to Steel, Stainless Steel, Related Alloys, and Ferroalloys*

ASTM E4, *Standard Practices for Force Verification of Testing Machines*

ASTM E10, *Standard Test Method for Brinell Hardness of Metallic Materials*

ASTM E18, *Standard Test Methods for Rockwell Hardness of Metallic Materials*

ASTM E23, *Standard Test Methods for Notched Bar Impact Testing of Metallic Materials*

ASTM E83, *Standard Practice for Verification and Classification of Extensometer Systems*

ASTM E92, *Standard Test Method for Vickers Hardness of Metallic Materials*

ASTM E213, *Standard Practice for Ultrasonic Examination of Metal Pipe and Tubing*

ASTM E309, *Standard Practice for Eddy-Current Examination of Steel Tubular Products Using Magnetic Saturation*

ASTM E570, *Standard Practice for Flux Leakage Examination of Ferromagnetic Steel Tubular Products*

ASTM E709, *Standard Guide for Magnetic Particle Testing*

4 Terms, definitions, symbols and abbreviated terms

4.1 Terms and definitions

For the purposes of this document, the terms and definitions in ASTM A941 for heat treatment operations and the following apply.

4.1.1

bevel diameter

outer diameter of the sealing shoulder of a rotary shouldered connection

4.1.2

defect

imperfection of sufficient magnitude to warrant rejection of the product based on criteria defined in this International Standard

[ISO 11960:2004, definition 4.1.11]

4.1.3

drill-pipe

drill-pipe body with weld-on tool joints

4.1.4

drill-pipe body

seamless pipe with upset ends

See Figure B.1.

4.1.5

drill-pipe-body manufacturer

firm, company or corporation that operates facilities for making drill-pipe bodies and is responsible for compliance with the requirements of this International Standard applicable to the drill-pipe body

See 7.21.

4.1.6

drill-pipe manufacturer

firm, company or corporation responsible for compliance with all the applicable requirements of this International Standard

See 6.16.

4.1.7

drill-pipe torsion-strength ratio

torsion strength of the tool-joint connection divided by the drill-pipe-body torsion strength

4.1.8

drill-pipe weld neck

machined part of the drill-pipe comprising the tool-joint weld neck, the weld and the drill-pipe-body upset

See Figure B.1.

4.1.9

elephant hide

wrinkled outside diameter surfaces of the drill-pipe body caused by the upsetting process

4.1.10

essential variable

variable parameter in which a change affects the mechanical properties of the weld joint

4.1.11**gouge**

elongated groove or cavity caused by mechanical removal of metal

4.1.12**hard banding**

application of material onto tool joints to reduce external wear of the tool joint

NOTE Also known as hard facing.

4.1.13**hardness number**

result from a single hardness impression

4.1.14**heat****heat of steel**

metal produced by a single cycle of a batch-melting process

4.1.15**heat analysis**

chemical analysis representative of a heat as reported by the metal producer

[ISO 11960:2004, definition 4.1.15]

4.1.16**imperfection**

discontinuity in the product wall or on the product surface that can be detected by an NDE method included in this International Standard

[ISO 11960:2004, definition 4.1.16]

4.1.17**indication**

evidence of a discontinuity that requires interpretation to determine its significance

4.1.18**inspection**

process of measuring, examining, testing, gauging or otherwise comparing the product with the applicable requirements

4.1.19**label 1**

dimensionless designation for the drill-pipe-body size that may be used when ordering

4.1.20**label 2**

dimensionless designation for the drill-pipe-body mass per unit length that may be used when ordering

4.1.21**linear imperfection**

imperfection that includes, but is not limited to, seams, laps, cracks, plug scores, cuts, gouges and elephant hide

NOTE See API 5T1.

[ISO 11960:2004, definition 4.1.25]

4.1.22

lot
definite quantity of product manufactured under conditions that are considered uniform for the attribute being inspected

4.1.23

lot size
number of units in a lot

4.1.24

manufacturer
one or more of the following, depending on the context: the maker of drill-pipe, the maker of drill-pipe body or the maker of tool joints

4.1.25

mean hardness number
result of averaging the hardness numbers for the single specimen or location being evaluated

4.1.26

non-essential variable
variable parameter in which a change may be made in the WPS without re-qualification

4.1.27

non-linear imperfection
imperfection that includes, but is not limited to, pits

See API Std 5T1.

4.1.28

pipe body
seamless pipe excluding upset and upset-affected areas

See Figure B.1.

4.1.29

procedure qualification record
PQR
written documentation stating an assessment that a specific WPS produces welds in accordance with the requirements of this International Standard.

4.1.30

product
drill-pipe, drill-pipe body or tool joint

4.1.31

purchaser
party responsible for both the definition of requirements for a product order and for payment for that order

[ISO 11960:2004, definition 4.1.35]

4.1.32

quench crack
crack in steel resulting from stresses produced during the transformation from austenite to martensite

NOTE This transformation is accompanied by an increase in volume.

[ISO 11960:2004, definition 4.1.36]

4.1.33**rotary shouldered connection**

connection used on drill string elements which has tapered threads and sealing shoulders

4.1.34**rotary friction welding**

solid state welding under compressive-force contact of work-pieces rotating relative to one another along a common axis to increase temperature and plastically displace material from the faying surfaces

NOTE Either direct drive or inertia friction welding is acceptable.

4.1.35**sample**

one or more units of product selected from a lot to represent that lot

4.1.36**seamless pipe**

wrought steel tubular product made without a weld seam

NOTE It is manufactured by hot working and, if necessary, by subsequently cold-working or heat-treating, or a combination of these operations, to produce the desired shape, dimensions and properties.

[ISO 11960:2004, definition 4.1.37]

4.1.37**tool joint**

forged or rolled steel component for drill-pipe designed to be welded to the drill-pipe body and having a rotary shouldered connection

4.1.38**tool-joint box**

threaded connection on tool joints that has internal threads

4.1.39**tool-joint manufacturer**

firm, company or corporation that operates facilities for making tool joints and is responsible for compliance with the requirements of this International Standard applicable to the tool joint

See 8.14.

4.1.40**tool-joint pin**

threaded connection on tool joints that has external threads

4.1.41**upset ovality**

difference between the largest and smallest diameter in a plane perpendicular to the axis of the upset

4.1.42**weld zone**

zone comprising the weld line and the heat-affected areas on either side of the weld line caused by the friction welding and subsequent heat-treatment processes

4.1.43**welding machine and welding operator performance qualification****WPQ**

written procedure used to demonstrate that a welding machine and welding operator combination has the capability to use the WPS to produce a weld meeting the requirements of this International Standard

NOTE It includes records from the qualification tests.

4.1.44

welding procedure specification

WPS

written procedure that provides instructions to the welding operator for making production welds in accordance with the requirements of this International Standard

NOTE It includes all essential variables and non-essential variables for friction welding of tool joints to drill-pipe body. A WPS applies to all those welds, of which each element has the same specified dimensions and chemistry, that are grouped according to a documented procedure that ensures a predictable response to weld-zone treatment for a particular grade.

4.2 Symbols and abbreviated terms

A_{dp}	cross-sectional area of the drill-pipe body based on the specified dimensions of the pipe body
A	cross-sectional area of the tensile specimen, expressed in square millimetres (square inches)
A	length of reduced section, expressed in millimetres
A_w	minimum cross-sectional area of the weld zone
D	tool-joint outside diameter (pin and box)
C_m	standard Charpy impact energy, expressed in Joules;
C	standard Charpy impact energy, expressed in foot-pounds.
D_{dp}	pipe-body outside diameter
D_f	bevel diameter (pin and box)
D_j	external diameter on the tool-joint neck, which becomes D_{te} after welding and final machining
D	diameter of round bar
D_{te}	outside diameter of the drill-pipe weld after machining
D_{0u}	drill-pipe-body upset outside diameter
d_{dp}	pipe-body inside diameter
d_j	internal diameter of the tool-joint neck, which becomes d_{te} after welding and final machining
d_p	tool-joint-pin inside diameter
d_{te}	inside diameter of the drill-pipe weld after machining
d_{0u}	drill-pipe-body upset inside diameter
EU	external upset
e	minimum extension in a gauge length of 50,8 mm (2.0 in)
e_m	minimum elongation
e_w	drill-pipe-body mass gain or loss due to end finishing. For plain-end non-upset pipe, e_w equals zero
G	gauge length
ID	inside diameter

IEU	internal-external upset
IU	internal upset
L	length of drill-pipe with weld-on tool joint (from shoulder to shoulder)
L_b	length of box-tool joint outside diameter including connection bevel and hard band; see Figures B.1 and B.12
L_{eu}	drill-pipe-body external upset length
L_{iu}	drill-pipe-body internal upset length
L_{pb}	length of pin-tool-joint outside diameter, including connection bevel; see Figures B.1 and B.12
L_{pe}	length of drill-pipe body (without tool joint)
m_{eu}	drill-pipe-body external upset taper length
m_{iu}	drill-pipe-body internal upset taper length
N	fraction or number with a fraction
NDE	non-destructive examination
OD	outside diameter
PQR	procedure qualification record
PSL	product specification level
R	minimum radius of fillet
RSC	rotary shouldered connection
T_S	tensile strength
t	pipe-body wall thickness
U	upset dimension
U_{dp}	minimum specified tensile strength
UT	ultrasonic testing
W	width
W_L	approximate calculated mass of a piece of drill-pipe body of length L_{pe}
WPQ	welder performance qualification
WPS	welding procedure specification
w_{dp}	approximate linear mass of the drill-pipe
w_{pe}	plain-end pipe-body unit mass (without upsets)
Y_{min}	specified minimum yield strength, see Table A.5 or Table C.5
Y_w	weld zone yield strength

5 Information to be supplied when placing orders for drill-pipe

5.1 When placing orders for drill-pipe to be manufactured in accordance with this International Standard, the purchaser shall specify the following on the purchase agreement:

Requirements	Reference
Document number(s)	ISO 11961 or API Spec 5 DP
Quantity	
Label 1	Table A.1 or Table C.1
Label 2	Table A.1 or Table C.1
Grade	Table A.1 or Table C.1
Upset type (internal, external or internal-external upset)	Table A.1 or Table C.1
RSC type or other special connection by agreement between purchaser and manufacturer	Table A.1 or Table C.1, or 6.2.2
Range or special length and tolerance by agreement between purchaser and manufacturer	Table A.3 or Table C.3
Delivery date and shipping instructions	
Inspection by purchaser	Annex D
Documentation	6.17

5.2 The purchaser shall also specify in the purchase agreement his requirements concerning the following stipulations, which are optional with the purchaser:

Requirements	Reference
Tool-joint outside diameter	6.2.2
Tool-joint inside diameter of the pin end	6.2.2
Length of pin-tool-joint outside diameter	6.2.6
Length of box-tool-joint outside diameter	6.2.6
Under-thickness tolerance if less than 12,5 %	7.2.6
Type of heat treatment for drill-pipe body: grade E only	7.4.3
Hard banding: type, location, dimensions and acceptance criteria	8.4.7
NOTE Hard banding reduces the length of the tool-joint outside diameter available for tong placement.	
Pipe coatings: internal and/or external	6.4.5, 6.4.6 and 7.4.4
Special threads on tool joints	8.2.5
Specific thread or storage compound	6.4.7
Thread-protector type	6.4.7 and 8.4.8
Marking requirements	6.15, 7.20 and 8.13
Individual drill-pipe traceability	6.5

Supplementary requirements

Non-destructive examination for grades E, X and G	Clause E.2, SR2
Test certificates	Clause E.3, SR15
Charpy V-notch (CVN) impact toughness testing of grade E pipe body	Clause E.4, SR19
Alternative low-temperature Charpy V-notch impact testing	Clause E.5, SR20
Weld-zone testing frequency	Clause E.6, SR23
Charpy V-notch: increased weld-zone requirements	Clause E.7, SR24
For PSL-2 or PSL-3	Annex G

6 Requirements for drill-pipe

6.1 General

The drill-pipe shall be made from drill-pipe body manufactured in accordance with Clause 7 and tool joints manufactured in accordance with Clause 8. Areas of the drill-pipe body and tool joint affected by the welding and finishing processes are addressed in Clause 6.

6.2 Dimensions, masses and connections

6.2.1 Standard configuration

The configuration of drill-pipe shall correspond to Figure B.1. Drill-pipe shall be furnished with dimensions and tolerances as in Tables A.1 and A.2 or Tables C.1 and C.2 and/or in the purchase agreement. All dimensions shown without tolerances are related to the basis for design and are not subject to measurement to determine acceptance or rejection of product. Drill-pipe dimensions that are not in this International Standard or in the purchase agreement are at the manufacturer's discretion.

Rotary shouldered connections shall conform to the dimensions, together with the tolerances, in ISO 10424-2 or API Spec 7-2. Right-hand thread connections shall be considered standard.

6.2.2 Alternative configurations

When specified in the purchase agreement, drill-pipe shall be furnished in dimensional configurations not defined in this International Standard. In this case, dimensions, tolerances and markings shall be agreed between the purchaser and manufacturer. The drill-pipe body and tool joint shall be modified in accordance with this agreement but the drill-pipe shall otherwise be manufactured in accordance with the requirements of this International Standard.

The outside diameter of the box tool joint, D , and inside diameter of the pin tool joint, d_p , dimensions in Table A.1 or Table C.1, result in a drill-pipe torsion-strength ratio 0,8 or greater. Changes in the OD and ID of the tool joints can result in a lower drill-pipe torsion-strength ratio, which should be determined by the purchaser to be suitable for the intended application.

6.2.3 Drill-pipe weld neck diameters

The drill-pipe weld diameters, D_{te} and d_{te} , as shown in Figure B.1, apply to the finished product after the tool joint is welded to the drill-pipe body and machined and/or ground. The outside diameter, D_{te} , shall meet the requirements of Table A.1 or Table C.1, and 6.3.2. The inside diameter, d_{te} , shall meet the requirements of 6.3.2 and may be different on the pin and box weld zones.

6.2.4 Tool-joint inside diameters

The tool-joint-pin inside diameter, d_p , shall meet the requirements in Table A.1 or Table C.1. The tool-joint-box inside diameter is at the manufacturer's discretion but shall not be less than the tool-joint-pin internal diameter, d_p .

6.2.5 Length

Drill-pipe shall be furnished in length ranges conforming to Table A.3 or Table C.3 or other lengths and tolerances as specified in the purchase agreement.

The drill-pipe manufacturer shall specify the lengths and tolerances of the drill-pipe body and tool joints such that the required length of each drill-pipe is achieved.

6.2.6 Length of tool-joint outside diameter

The length of pin-tool-joint outside diameter, L_{pb} , and the length of box-tool-joint outside diameter, L_b , in Table A.1 or Table C.1, may be increased by agreement between purchaser and manufacturer.

6.2.7 End-drift

Each drill-pipe shall be end-drift tested throughout the length of the tool joints and upsets with a cylindrical mandrel having a minimum diameter of 3,2 mm (0.125 in) smaller than the specified inside diameter of the pin end, d_p . The drift mandrel shall be at least 100 mm (4 in) long.

NOTE Drift testing of the full length of the drill-pipe is not required.

6.2.8 Tool-joint alignment

The maximum misalignment between the longitudinal axis of the drill-pipe body and the longitudinal axis of the welded-on tool joint shall not exceed the following:

- for parallel misalignment: 4 mm (0,157 in) total indicator reading;
- for angular misalignment: 8 mm/m (0,008 in/in) for label 1: 4-¹/₂ and larger;
10 mm/m (0,010 in/in) for smaller than label 1: 4-¹/₂.

The axis of the tool joint shall be determined on the surface of the outside diameter, D , that is unaffected by markings or hard banding. The axis of the drill-pipe body shall be determined over a minimum length of 400 mm (15 in) on the outside surface of the pipe body.

6.2.9 Weld-zone profile

The weld zone shall have no sharp corners or drastic changes of section. The internal weld-zone profile shall not cause a 90° hook-type tool to hang up.

6.3 Material requirements

6.3.1 General

The material properties of the drill-pipe body and the tool joint shall be as in Tables A.4 to A.8 or Tables C.4 to C.8 inclusive.

6.3.2 Weld-zone yield strength

The yield load of the weld zone in tension shall be greater than the yield load of the drill-pipe body as given by Equation (1):

$$(Y_w \times A_w) \geq (Y_{\min} \times A_{dp}) \quad (1)$$

where

A_{dp} is the cross-sectional area of the drill-pipe body based on the specified dimensions of the pipe body;

A_w is the minimum cross-sectional area of the weld zone;

Y_{\min} is the specified minimum yield strength of the drill-pipe body;

Y_w is the weld zone minimum yield strength (determined by the manufacturer based on the design).

The method for calculating the minimum cross-sectional area, A_w , of the weld zone shall be as given in Equation (2):

$$A_w = 0,7854 \times (D_{te,\min}^2 - d_{te,\max}^2) \quad (2)$$

where

$d_{te,\max}$ is the maximum allowable inside diameter specified by the drill-pipe manufacturer;

$D_{te,\min}$ is the minimum allowable outside diameter specified by the drill-pipe manufacturer.

6.3.3 Weld-zone hardness

For surface hardness, no hardness number shall exceed 37 HRC or equivalent.

For the through-wall hardness test, the mean hardness number of the weld zone shall not exceed 37 HRC or 365 HV10.

6.3.4 Weld-zone Charpy V-notch absorbed-energy requirements

The minimum absorbed energy requirements shall be as in Table A.8 or Table C.8. In addition, not more than one impact specimen shall exhibit an absorbed energy below the minimum average absorbed-energy requirement, and in no case shall an individual impact specimen exhibit an absorbed energy below the minimum specimen absorbed-energy requirement.

Additional requirements for PSL-3 are in Annex G.

6.3.5 Weld-zone Charpy V-notch absorbed energy — Alternative requirements

When specified in the purchase agreement, the absorbed energy shall meet the SR20 and/or the SR24 requirements in Clause E.5 and/or Clause E.7 respectively (see also Table A.8 or Table C.8).

6.3.6 Weld-zone transverse side bend properties

The guided-bend specimens shall have no open discontinuity in the weld zone exceeding 3 mm (0,125 in) measured in any direction on the convex surface of the specimen after bending. Open discontinuities occurring on the corner of the specimen during testing shall not be considered unless there is definite evidence that they result from lack of fusion, inclusions or other internal discontinuities.

6.4 Process of manufacture for drill-pipe

6.4.1 Processes requiring validation

Final operations performed during drill-pipe manufacturing that affect compliance as required in this International Standard (except chemical composition and dimensions) shall have their process validated.

Those processes requiring validation are welding and weld heat treatment.

6.4.2 Welding qualification

The manufacturer shall develop, qualify and use a welding procedure, including post-weld heat treatment (WPS and PQR), in accordance with the ASME Boiler and Pressure Vessel Code, Section IX. The procedure shall identify the essential variables and non-essential variables and address the permissible number of re-heat treatments.

The PQR shall include, as a minimum, the data of the specific variables (both essential and non-essential) used to weld a tool joint to a drill-pipe body and the results of all mechanical tests to verify the properties in 6.3 carried out on specimens taken from the test weld.

In addition, the manufacturer shall undertake macrostructural examination of the weld to verify that the weld exhibits complete bonding and freedom from cracks.

The manufacturer shall qualify the welding machines and welding operators to a specific WPQ for each WPS utilized by the operators.

6.4.3 Welding of tool joints to drill-pipe body and post-weld heat treatment

The welding of the tool joint to the drill-pipe body shall be by the rotary friction welding process.

A post-weld heat treatment shall be performed through the entire thickness and from the weld line to beyond where the flow lines of the tool joint and drill-pipe body material change direction as a result of the welding process. The weld shall be austenitized, cooled below the transformation temperature and tempered at a minimum temperature of 593 °C (1 100 °F).

6.4.4 Weld machining

The weld area shall be machined and/or ground, both externally and internally, to produce a flush surface (visually free from gouges or abrupt changes in section).

Tool marks from normal machining operations shall be acceptable.

6.4.5 Internal coating

When specified in the purchase agreement, drill-pipe shall be internally coated over the full length, except the thread. The type of coating shall be specified in the purchase agreement and the application and inspection shall be carried out in accordance with an agreed documented procedure.

6.4.6 External coating

Unless otherwise specified in the purchase agreement, the drill-pipe shall be given an external coating for protection from corrosion during transit. The coating shall be rated to protect the drill-pipe for at least three months and it should be smooth, hard to the touch and with minimum sags.

6.4.7 Thread protection

Threads and shoulders of rotary shouldered connections shall be equipped with thread protectors to protect them from damage during transportation and storage. Unless otherwise specified in the purchase agreement, the type of thread protector is at the manufacturer's discretion.

A thread compound, suitable for rotary shouldered connections, shall be applied over the clean threads and shoulders before protectors are installed. Unless otherwise specified in the purchase agreement, the type of thread compound is at the manufacturer's discretion.

When specified in the purchase agreement, a storage compound shall be applied instead of the thread compound.

6.5 Traceability

The drill-pipe manufacturer shall establish and follow procedures for maintaining traceability to any applicable supplementary requirement and/or PSL requirement, as well as to drill-pipe-body heat and tool-joint heat as in Clauses 7 and 8, respectively.

Lot identity of all welds shall be maintained until all required tests are performed and conformance with specified requirements has been documented. The procedures shall provide means for tracing the welds to the lot and to mechanical and inspection test results.

When additional traceability is required, the details shall be agreed and be specified in the purchase agreement.

6.6 Inspection and testing — General

6.6.1 Inspection and test equipment calibration

The manufacturer shall determine and document the appropriate calibration frequency and procedures (including occurrences of out-of-calibration and the consequences on products) in order to be able to certify that all products conform to the requirements of this International Standard.

6.6.2 Dimensional inspection

The drill-pipe weld diameters, D_{te} and d_{te} , shall be verified, after final machining and/or grinding according to a documented procedure, to meet the requirements of 6.2.3.

6.6.3 Drill-pipe length

The drill-pipe length, L , (see Figure B.1) shall be measured from shoulder to shoulder unless otherwise specified in the purchase agreement. This length shall be recorded and reported to the purchaser. The accuracy of length-measuring devices shall be $\pm 0,03$ m (± 0.1 ft). Drill-pipe length determination shall be in metres and hundredths of a metre (feet and tenths of a foot).

6.6.4 Straightness

All drill-pipe shall be visually examined for straightness. The straightness of questionably bent pipes or crooked extremities shall be measured in accordance with 7.14.

6.6.5 End-drift test

End-drift testing shall be performed with a drift mandrel conforming to the requirements of 6.2.7. It is permissible for the ends of the drift mandrel, extending beyond the specified cylindrical portion, to be shaped to permit easy entry into the drill-pipe. The drift mandrel shall pass freely through the length of the drill-pipe tool joint and upset by the use of a manual or power drift procedure. In case of dispute, the manual drift procedure shall be used.

6.6.6 Internal profile

Each end of every drill-pipe shall be visually examined for compliance with the requirements of 6.2.9. Questionable ends shall be examined using the following method.

The weld-zone configuration inspection shall be made with a 90° hook-type tool (see Figure B.2). The contact pin shall be visually determined to be attached perpendicular to the handle. The contact-point radius shall not exceed the inside radius of the weld zone being inspected. Sharp edges on the contact point shall be removed (see contact point on Figure B.2). The 90° hook-type-tool contact point should be maintained perpendicular to the longitudinal axis of the weld zone while the contact point is passed axially throughout the weld-zone length. Pressure on the contact point shall be no greater than the pressure created by the weight of the 90° hook-type tool.

6.6.7 Tool-joint alignment

Tool-joint alignment shall conform to the requirements in 6.2.8 and shall be verified according to a documented procedure.

6.7 Testing of welds

6.7.1 Lot size

A lot shall consist of all those welds that are produced in a single production run (either continuous or interrupted) on the same welding machine (without any modification of the set-up parameters) using the same qualified procedures (WPS and WPQ).

6.7.2 Test specimens

All initial test specimens for the weld zone, where size allows, shall be taken from the same sample.

6.8 Tensile test

6.8.1 Procedures

The tensile test shall be performed at room temperature in accordance with ISO 6892 or ASTM A370.

Tests may be carried out on semi-finished products, that is, before final machining operations but after final heat treatment.

The fracture shall not occur at the weld line.

6.8.2 Test equipment calibration

Tensile test machines shall have been calibrated within a period of 15 months preceding any test, in accordance with the procedures in ISO 7500-1 or ASTM E4. Extensometers shall have been calibrated within a period of 15 months preceding any test, in accordance with the procedures in ISO 9513 or ASTM E83. Retention of records shall be in accordance with 6.17.4 and Table A.9 or Table C.9.

6.8.3 Specimens

A longitudinal section of sufficient length to include the entire weld zone shall be suitably prepared and etched to determine the location of the weld zone relative to the weld line and transverse grain flow. This etched section shall be used to ensure that the tensile specimen includes the full weld zone within the reduced section as shown in Figure B.3.

The largest possible round-bar tensile specimens, in accordance with the requirements of ISO 6892 or ASTM A370, 0,2 % offset method, shall be taken from the longitudinal section location as shown in Figure B.3. Specimens with a diameter of 12,7 mm (0.500 in) are preferred. Specimens with a diameter of 8,9 mm (0.350 in) or 6,4 mm (0.250 in) are suitable alternatives for thin sections.

6.8.4 Frequency

The tensile-test frequency for the weld shall be as in Table A.10 or Table C.10.

Additional requirements for PSL-2 and PSL-3 are in Annex G.

For an alternative test frequency, see Clause E.6, SR23.

6.8.5 Defective specimen

Specimens showing material imperfections or defective preparation, whether observed before or after testing, may be discarded, and replacements shall be considered as original specimens.

6.8.6 Re-tests

If the initial tensile test fails to conform to the specified requirements, the manufacturer may elect to test two additional specimens from the same weld. If both of the additional specimens pass, the lot shall be accepted.

If one or more of the additional specimens fail to conform to the requirements, the lot shall be rejected. Rejected lots may be re-heat-treated and tested as new lots.

If insufficient material remains for the re-test specimens to be obtained from the original sample, then it is permitted to obtain specimens from another weld within the same lot.

6.9 Hardness test

6.9.1 Procedures

Hardness tests shall be made in accordance with the appropriate standards as follows:

- ISO 6506-1 or ASTM E10;
- ISO 6507-1 or ASTM E92;
- ISO 6508-1 or ASTM E18.

Hardness indentations shall not be closer than three indentation diameters from other indentations measured centre-to-centre.

6.9.2 Surface hardness test

Each weld zone shall be hardness tested on the outside surface at three places, $120^\circ \pm 15^\circ$ apart. Selection of the hardness testing method is at the manufacturer's option, including the use of an alternative test method. In such a case, the manufacturer shall demonstrate the equivalence of the test result to those of one of the standards mentioned in 6.9.1.

6.9.3 Surface hardness — Re-test

All welds with a hardness number that exceeds 37 HRC shall be re-tested or rejected. For any hardness number that exceeds 37 HRC, one more hardness test shall be made in the immediate area. If the new hardness number does not exceed 37 HRC, the weld shall be accepted. If the new hardness number exceeds 37 HRC, the weld shall be rejected. The manufacturer may elect to re-heat-treat the weld in accordance with the same qualified procedure and perform the surface hardness test again.

6.9.4 Through-wall hardness test

The through-wall hardness test frequency of the weld zone shall be as in Table A.10 or Table C.10.

A Rockwell mean hardness number is the average of three Rockwell C-scale numbers taken at 2,5 mm to 6,4 mm (0.10 in to 0.25 in) from the outside surface and from the inside surface on the pipe and tool-joint sides of the weld line (that is 12 hardness numbers and 4 Rockwell mean hardness numbers on each weld, as shown in Figure B.3).

6.9.5 Through-wall hardness — Re-tests

All weld test pieces with a mean hardness number that exceeds 37 HRC shall be re-tested or the lot represented by the test shall be rejected. Before re-testing, the test surface may be re-ground. If the re-test mean hardness numbers do not exceed 37 HRC, the lot shall be accepted. If any re-test mean hardness number exceeds 37 HRC, the lot of welds represented by the test piece shall be rejected. Rejected lots may be re-heat-treated and tested as new lots.

6.10 Charpy V-notch impact test

6.10.1 Procedures

A test shall consist of a set of three longitudinal specimens taken from one weld. Charpy V-notch impact tests as in ASTM A370 and ASTM E23 shall be conducted at a temperature of $21\text{ °C} \pm 3\text{ °C}$ ($70\text{ °F} \pm 5\text{ °F}$). For alternative standardized test temperatures, see Clause E.5, SR20, and PSL-3 in Table A.8 or Table C.8.

Tests conducted at any temperature lower than the specified temperature are acceptable provided the absorbed-energy requirements at the specified temperature are achieved.

Additional requirements for PSL-2 and PSL-3 are in Annex G.

6.10.2 Specimen size and orientation

The impact test specimen shall not be smaller than the largest size shown in Table A.11 or Table C.11 based on the specified drill-pipe weld neck diameter (and rounded to the next smaller specified outside diameter if required) and the calculated weld neck thickness (based on specified dimensions).

Specimens shall be removed from the weld longitudinally with respect to the axis of the pipe with the notch oriented in a radial direction as shown in Figure B.3. The centre of the notch in the specimen shall be located on the weld line.

6.10.3 Test frequency

The impact test frequency for the weld shall be as in Table A.10 or Table C.10.

Additional requirements for PSL-2 and PSL-3 are in Annex G.

For an alternative test frequency, see Clause E.6, SR23.

6.10.4 Re-tests

If the requirements of 6.3.4 are not met and not more than one specimen is below the minimum specimen absorbed-energy requirement, the manufacturer may elect either to reject the lot or to re-test a set of three additional specimens from the same weld test piece. For all three of these specimens, the absorbed energy shall be equal to or greater than the minimum average absorbed energy in Table A.8 or Table C.8 or the lot shall be rejected. If insufficient material remains for the re-test specimens to be obtained from the original sample, then it is permitted to obtain specimens from another weld from the same lot.

If more than one specimen in the initial test is below the minimum specimen absorbed-energy requirement, then the manufacturer may elect either to reject the lot or to re-test an additional set of three specimens from each of three additional welds from the same lot. If these additional sets of specimens do not meet the initial test requirements, then the lot shall be rejected.

Rejected lots may be re-heat-treated and tested as new lots.

6.10.5 Defective specimens

Specimens showing material imperfections or defective preparation, whether observed before or after testing, may be discarded, and replacements shall be considered as original specimens. Specimens shall not be judged defective simply because they fail to exhibit the minimum absorbed energy requirements.

6.11 Transverse side-bend test

6.11.1 Procedure

The guided bend test shall be carried out in accordance with the ASME Boiler and Pressure Vessel Code, Section IX, paragraphs QW-161.1 and QW-162.1. The specimen shall be bent until the two branches of the specimen form an angle of not greater than 40° under load, as shown in Figure B.3. The weld zone shall be completely within the bend portion of the specimen after bending. A test shall consist of one specimen bent in the clockwise direction and another specimen bent in the counter-clockwise direction relative to the pipe axis.

6.11.2 Specimens

One set of two specimens shall be removed from the weld zone of the test piece. The weld zone shall be in the centre of longitudinal specimens. The test specimens shall be of full wall thickness, approximately 9,5 mm ($\frac{3}{8}$ in) wide, and the length shall be 150 mm (6 in) minimum.

6.11.3 Test frequency

The transverse side-bend test frequency shall be as in Table A.10 or Table C.10.

For an alternative test frequency, see Clause E.6, SR23.

6.11.4 Re-tests

If only one of the guided-bend specimens fail to conform to the specified requirements, the manufacturer may elect to reject the lot or to test an additional set of two specimens from the same weld test piece. If both of the re-test specimens meet the specified requirements, the lot shall be accepted. If one or both of the re-test specimens fail to meet the specified requirements, the lot shall be rejected.

It is preferred that re-test specimens be obtained from the same sample as the original test specimen(s). However, if the re-test specimens cannot be obtained from the original sample, it is permissible to obtain specimens from another weld within the same lot.

Rejected lots may be re-heat-treated and tested as a new lot.

6.12 Imperfections and defects in drill-pipe

6.12.1 General

Drill-pipe shall be free from defects as defined in this International Standard.

6.12.2 Weld zone defects

Any weld-zone imperfection detected by visual inspection, as in 6.13, or wet fluorescent magnetic-particle inspection, as in 6.14.2, shall be considered to be a defect.

Any imperfection detected by ultrasonic inspection that produces a signal equal to or greater than the signal produced by the reference standard described in 6.14.4 shall be considered a defect.

Quench cracks shall be considered defects and shall be cause for rejection of the product.

6.12.3 Process control plan

The manufacturer, based on knowledge of the production process and the requirements of 6.13 and 6.14, shall apply a process control plan that ensures compliance with the requirements of 6.12.2.

6.13 Visual inspection of the drill-pipe weld zone

6.13.1 General

Each weld zone shall be visually inspected over the entire outside surface for the detection of defects.

This inspection shall be carried out by trained personnel. Visual acuity requirements shall be documented by the manufacturer. Personnel compliance with these requirements shall be documented.

NOTE Examples of visual acuity requirements are in ISO 11484 or ASNT SNT-TC-1A.

Documented lighting standards for visual inspection shall be established by the manufacturer. The minimum illumination level at the inspection surface shall be 500 lux (50 foot-candles).

The visual inspection for defects may be at any appropriate point in the manufacturing process after machining.

6.13.2 Disposition of defects

Defects shall be completely removed by grinding or machining. All grinding shall be blended smooth. The dimensions after grinding shall comply with the requirements of 6.2.

6.14 Non-destructive examination of the weld zone

6.14.1 General

All NDE operations (except visual inspection) referred to in this International Standard shall be conducted by NDE personnel qualified in accordance with ISO 11484 or ASNT SNT-TC-1A.

Surfaces to be inspected shall be machined and/or ground before inspection.

When specified in the purchase agreement, the provisions for purchaser inspection of the weld zone and/or witnessing of NDE operations shall be in accordance with Annex D.

The inspections performed in accordance with 6.14, with the equipment calibrated to the specified reference indicators, should not be construed as assuring that the material requirements in 6.12 have been met.

The manufacturer shall determine the appropriate NDE equipment verification frequency in order to be able to certify that all products conform to the requirements of this International Standard.

6.14.2 Wet fluorescent magnetic-particle inspection

The entire outside surface of the weld zone shall be wet-fluorescent-magnetic-particle inspected for the detection of transverse imperfections in accordance with ISO 13665 or ASTM E709. Wet particle concentration shall be checked every 8 h or each shift change. The minimum black-light intensity at the examination surface shall not be less than 1 000 $\mu\text{w}/\text{cm}^2$.

6.14.3 Ultrasonic inspection — Procedure

Each weld zone shall be ultrasonically inspected from the pipe side around the circumference with the beam directed toward the weld. Shear wave/angle beam ultrasonic equipment capable of inspection of the entire weld zone shall be used. The inspection shall be applied in accordance with the manufacturer's documented procedure. The instrument gain setting during inspection shall not be set lower than the gain setting when checked against the reference standard. In case of dispute, the transducer used shall generate a square 2,25 MHz frequency attached to a $45^\circ \pm 5^\circ$ Lucite¹⁾ wedge (the angle refers to the entry angle in the material).

6.14.4 Ultrasonic inspection — Reference standard

A reference standard shall be used to demonstrate the effectiveness of the inspection equipment and procedures at least once every working shift. The equipment shall be adjusted to produce a well defined indication when the reference standard is scanned in a manner simulating the inspection of the product. The reference standard shall have the same specified diameter and wall thickness and the same acoustic properties and surface finish as the weld zone being inspected and may be of any convenient length as determined by the manufacturer. The reference standard shall contain a through-drilled hole as in Figure B.4.

The manufacturer shall use a documented procedure to establish the reject threshold for ultrasonic inspection. The through-drilled hole described in Figure B.4 shall be detected under normal operating conditions.

6.14.5 Ultrasonic inspection — System capability records

The manufacturer shall maintain NDE system records verifying the capabilities of the system(s) in detecting the reference indicators used to establish the equipment test sensitivity.

The verification shall cover, as a minimum, the following criteria:

- a) coverage calculation (i.e. scan plan);
- b) capability for the intended wall thickness;
- c) repeatability;
- d) transducer orientation that provides detection of defects typical of the manufacturing process (see 6.14.3);
- e) documentation demonstrating that defects typical of the manufacturing process are detected;
- f) threshold-setting parameters;

In addition, the manufacturer shall maintain documentation relating to

- NDE system operating procedures,
- NDE equipment description,

1) Lucite is an example of a suitable product available commercially. This information is given for the convenience of users of this International Standard and does not constitute an endorsement by ISO of this product.

- NDE personnel qualification information,
- dynamic test data demonstrating the NDE system/operation capabilities under production test conditions (not applicable to manual operations).

6.14.6 Disposition of defects

Defects detected by either wet fluorescent magnetic-particle inspection or ultrasonic inspection shall be completely removed by grinding or machining, or the weld shall be rejected. All grinding shall be blended smooth. The dimensions after grinding shall comply with the requirements of 6.2. The weld zone shall be re-inspected after grinding using the same inspection method originally used to detect the defect in order to verify complete removal of the defect.

6.15 Marking of drill-pipe

6.15.1 General

Drill-pipe manufactured in conformance with this International Standard shall be marked by the drill-pipe manufacturer as in 6.15. Additional markings may be applied, including those for applicable compatible standards, at the option of the manufacturer or as specified in the purchase agreement. Markings shall not overlap and shall be applied in such a manner as to not damage the drill-pipe.

The drill-pipe final marking shall be the responsibility of the drill-pipe manufacturer and shall include traceability (see 6.5).

6.15.2 Drill-pipe marking

The final marking of the drill-pipe shall consist of

- a) the traceability marking according to 6.15.3,
- b) marking on the drill-pipe body according to 6.15.4,
- c) marking on the tool joint according to 6.15.5.

6.15.3 Traceability marking

This marking (for traceability requirements, see 6.5) shall be die stamped on the pin taper, as shown in Figure B.1, unless otherwise specified in the purchase agreement.

6.15.4 Drill-pipe marking on the pipe body

Drill-pipe-body paint stencil markings shall start approximately 1 m (40 in) from the box shoulder and shall include, in the following sequence, as a minimum:

- a) drill-pipe manufacturer's name or mark;
- b) "ISO 11961" and/or "Specification 5DP", as applicable; marking to indicate compliance with API Spec 5DP is at the manufacturer's option or as specified in the purchase agreement;
- c) API monogram marking requirements (see Annex H), if applicable;
- d) date of drill-pipe manufacture (month and year of welding).

The date of manufacture shall be a three- or four-digit number consisting of a one- or two-digit number indicating the month followed by the last two digits of the year in which the markings of Clause 6 are completed. This marking may be waived at the manufacturer's option (it is also marked on the base of the

tool-joint pin; see Figure B.5). Products manufactured in accordance with this edition of ISO 11961 during the period of overlap of application with the previous edition (see Foreword) may be identified by “00” as the overlap period designation rather than the month;

- e) size designation (label 1);
- f) mass designation (label 2);
- g) grade of the drill-pipe body;
- h) SR information applicable to the drill-pipe;
- i) L2 or L3 (indicating, respectively, PSL-2 or PSL-3) applicable to the drill-pipe.

EXAMPLE Paint-stencilled marking for a label 1: 2-3/8, label 2: 6.65, grade E PSL-2 drill-pipe manufactured by company ZZ in July 2007:

ZZ ISO 11961 707 2-3/8 6.65 E L2.

At the drill-pipe manufacturer's option or as specified in the purchase agreement, the drill-pipe-body manufacturer's marking may remain on the drill-pipe body or be obliterated by the drill-pipe manufacturer.

The paint-stencilled marking may be adversely affected when the drill-pipe is internally coated.

6.15.5 Drill-pipe marking on the tool joint

Unless otherwise specified in the purchase agreement, the tool joint shall be die stamped (the size of the die stamping shall be at the manufacturer's option) at the base of the pin as shown in Figure B.5 and include the following:

- a) drill-pipe manufacturer's name or mark;
- b) month welded: for example, “6” designates “June”;
- c) year welded: for example, “07” designates “2007”;
- d) drill-pipe-body manufacturer's name or mark, at the manufacturer's option;
- e) drill-pipe-body grade: for example, “E” designates “grade E” pipe body;
- f) product drill-pipe-body mass code number (See Table A.12 or Table C.12): for example, “2” designates a standard mass product; for designations not in Table A.12 or Table C.12, the mass code shall be by agreement between the purchaser and the manufacturer;
- g) tool-joint designation, at the manufacturer's option: for example, “NC50” designates an NC50 rotary-shouldered connection; for connections not in Table A.1 or Table C.1 the designation shall be as specified by the manufacturer.

Marking of the tool joint with grooves and flats shall be as specified in the purchase agreement.

Marking made by the tool-joint manufacturer on the outside surface of the tool joint may remain.

6.16 Minimum facility requirements for drill-pipe manufacturers

The drill-pipe manufacturer shall operate facilities for welding tool joints to drill-pipe body, for post-weld heat treatment and for machining the weld area.

Either the drill-pipe manufacturer shall have facilities for conducting all required tests and inspections or any of these tests or inspections may be provided by a subcontractor and may be located offsite. In the event that a subcontractor performs any of these services, the conduct of such inspections and tests shall be controlled and monitored by the drill-pipe manufacturer in accordance with a documented procedure.

6.17 Documentation requirements of drill-pipe

6.17.1 Standard documentation

The drill-pipe manufacturer shall provide the purchaser with the following:

- a) a certificate of compliance giving the product description and a statement that the drill-pipe has been manufactured, inspected and tested in accordance with, and is in compliance with, this International Standard and the purchase agreement; product description shall include as a minimum label 1, label 2, grade, range, RSC type and any other special requirements specified in the purchase agreement;
- b) a tally list giving the length, *L*, of each drill-pipe (see Figure B.1 and 6.6.3).

6.17.2 Supplementary documents

When specified in the purchase agreement, the requirements of Clause E.3, SR15, shall apply.

Additional requirements for PSL-2 and PSL-3 are in Annex G.

6.17.3 Electronic data interchange

The standard and/or supplementary documents (see 6.17.1 and 6.17.2) printed from or used in electronic form from an electronic data interchange (EDI) transmission shall be regarded as having the same validity as a counterpart printed in the drill-pipe manufacturer's facility. The content of the EDI-transmitted document shall meet the requirements of this International Standard and conform to any existing EDI agreement between the purchaser and the drill-pipe manufacturer.

6.17.4 Retention of records

Table A.9 or Table C.9 specifies records that shall be retained. Such records shall be retained by the drill-pipe manufacturer and shall be available to the purchaser on request for a period of five years after the date of purchase from the drill-pipe manufacturer.

7 Requirements for drill-pipe body

7.1 Information to be supplied when placing orders for drill-pipe bodies

7.1.1 When placing orders for drill-pipe bodies to be manufactured in accordance with this International Standard, the purchaser shall specify the following in the purchase agreement:

Requirements	Reference
Document number(s)	ISO 11961 or API Spec 5DP
Quantity	
Label 1 or specified outside diameter	Table A.1 or Table C.1
Label 2 or specified wall thickness	Table A.1 or Table C.1
Grade	Table A.1 or Table C.1
Type of pipe upset (internal, external or internal-external upset)	Table A.1 or Table C.1

Length and tolerance	
Delivery date and shipping instructions	
Inspection by purchaser	Annex D
Documentation	7.22

7.1.2 The purchaser shall also specify in the purchase agreement his requirements concerning the following stipulations, which are optional with the purchaser:

Requirements	Reference
Special upset configuration	7.2.2
Under thickness tolerance if less than 12,5 %	7.2.6
Type of heat treatment for drill-pipe body: grade E only	7.4.3
Impact requirements for grade E	Clause E.4, SR19
Alternative requirements for impact test	Clause E.5, SR20
PSL-2 or PSL-3	Annex G

7.2 Dimensional and mass requirements

7.2.1 General

The dimensions of the drill-pipe body shall correspond with the requirements in Tables A.2 and A.13 or A.14 or Tables C.2 and C.13 or C.14, unless otherwise specified in the purchase agreement.

For drill-pipe body furnished with upsets not in this International Standard, but otherwise manufactured in accordance with the requirements of this International Standard, special marking as in 7.20 is required.

7.2.2 Configuration

The configuration of drill-pipe body shall correspond to Figure B.1. Upset configurations shall correspond to Figure B.6 except as allowed in 6.2.2 or when otherwise specified in the purchase agreement.

7.2.3 Internal upset area

The internal upset taper area of the drill-pipe body shall have a smooth profile. The internal upset configuration shall have no sharp corners or drastic changes of section that can cause a 90° hook-type tool to hang up.

7.2.4 Outside-diameter tolerance

The outside-diameter tolerances of the drill-pipe body shall be in accordance with the requirements of Table A.2 or Table C.2. The outside-diameter tolerances behind the length, m_{eU} , apply to the outside diameter of the drill-pipe body immediately behind the upset for a distance of approximately 127 mm (5 in) for sizes smaller than label 1: 6-5/8 and a distance approximately equal to the outside diameter for label 1: 6-5/8. Measurements shall be made with callipers or snap gauges.

7.2.5 Inside diameter

The pipe-body inside diameter, d_{dp} , is calculated as given in Equation (3):

$$d_{dp} = D_{dp} - 2t \quad (3)$$

There is no tolerance on d_{dp} .

7.2.6 Pipe-body wall thickness and tolerance

The wall thickness at any place on the pipe body shall not be less than the specified thickness minus 12,5 %. When specified in the purchase agreement, the wall thickness under-tolerance may be less than 12,5 %.

7.2.7 Length

The drill-pipe body shall be supplied in lengths and tolerances as specified in the purchase agreement. The lengths and tolerances should be such that the required final length of drill-pipe is achievable.

7.2.8 Mass

The mass shall conform to the calculated mass for the end finish and dimensions specified in the purchase agreement, within the tolerances stipulated below. Calculated mass, W_L , expressed in kilograms (pounds), of a piece of drill-pipe body of length L_{pe} shall be determined in accordance with Equation (4):

$$W_L = (w_{pe} \times L_{pe}) + e_w \quad (4)$$

where

w_{pe} is the non-upset pipe mass per unit length, expressed in kilograms per metre (pounds per foot);

L_{pe} is the length of drill-pipe body, expressed in metres (feet);

e_w is the drill-pipe-body mass gain due to end finishing (see Tables A.13 and A.14 or Tables C.13 and C.14). For non-upset pipe, e_w equals zero. The method of calculation is defined in ISO/TR 10400 or ANSI/API 5C3.

Mass tolerance is as follows:

— single lengths: $\begin{matrix} +6,5 \\ -3,5 \end{matrix}$ %;

— order item: $\begin{matrix} 0 \\ -1,8 \end{matrix}$ %.

Order-item tolerance applies only for masses of 18 140 kg (40 000 lb) or more when shipped from a drill-pipe-body manufacturer.

Where an under-thickness tolerance smaller than 12,5 % is specified in the purchase agreement, the plus tolerance on mass for single lengths shall be increased to 19 % less the specified under-thickness tolerance.

EXAMPLE If an under-thickness tolerance of 10 % is specified in the purchase agreement, the plus tolerance on mass for single lengths is 19 % minus 10 %, or 9 %.

7.2.9 Straightness

Deviation from straight or chord height shall not exceed either of the following (see Figure B.7):

- a) 0,2 % of the total length of the drill-pipe body measured from one end to the other
- b) 3,2 mm (1/8 in) maximum drop in the transverse direction in a length of 1,5 m (5 ft) from each end.

7.2.10 Upset alignment

The outside and inside surfaces of the upset shall be aligned with the outside surface of the pipe body. The total indicator reading shall not exceed 2,4 mm (0.093 in) for the outside surface and 3,2 mm (0.125 in) for the inside surface.

7.2.11 Upset ovality

Maximum ovality, measured with a micrometer on the outside diameter of the upset shall not exceed 2,4 mm (0.093 in).

7.3 Material requirements

7.3.1 Chemical composition

The chemical composition shall be as in Table A.4 or Table C.4.

7.3.2 Tensile requirements

The pipe body shall conform to the requirements in Table A.5 or Table C.5. The upset ends shall conform to the requirements for the pipe body except that there is no requirement for elongation. Compliance with the requirements for the upset shall be qualified by a documented procedure.

The yield strength shall be the tensile stress required to produce the extension under load in Table A.6 or Table C.6, as determined by an extensometer.

The minimum pipe-body elongation, e , in a 50,8 mm (2.0 in) gauge length, expressed in percent rounded to the nearest 0,5 % for elongations less than 10 % and to the nearest unit percent for elongations of 10 % and greater, shall be that determined by Equation (5):

$$e = k \times \frac{A^{0,2}}{U_{dp}^{0,9}} \quad (5)$$

where

k is a constant equal to 1 944 (625 000);

A is the cross-sectional area of the tensile-test specimen, expressed in square millimetres (square inches), based on the specified outside diameter or nominal specimen width and specified wall thickness, rounded to the nearest 10 mm² (0.01 in²), or 490 mm² (0.75 in²) whichever is smaller;

U_{dp} is the minimum specified tensile strength, in megapascals (pounds per square inch).

Pipe-body minimum elongation values in accordance with Equation (5) for various sizes of tensile specimens and pipe grades are shown in Table A.7 or Table C.7. When elongation is recorded or reported, the record or report shall show the nominal width of the test specimen when strip specimens are used, the nominal diameter and gauge length when round-bar specimens are used, or shall state when full-section specimens are used.

7.3.3 Charpy V-notch absorbed-energy requirements — Grade E

There is no mandatory Charpy V-notch absorbed-energy requirement for the pipe body or the upset. See Clause E.4, SR19, for optional requirements.

Additional requirements for PSL-2 and PSL-3 are in Annex G.

7.3.4 Charpy V-notch absorbed-energy requirements — Grades X, G and S

The minimum absorbed-energy requirements of the pipe body shall be as in Table A.8 or Table C.8. In addition, not more than one impact specimen shall exhibit an absorbed energy below the minimum average absorbed-energy requirement, and in no case shall an individual impact specimen exhibit an absorbed energy below the minimum specimen absorbed-energy requirement.

There is no mandatory Charpy V-notch absorbed energy requirement for the upset.

Additional requirements for PSL-2 and PSL-3 are in Annex G.

7.3.5 Charpy V-notch absorbed-energy requirements — Alternative temperature

When specified in the purchase agreement, the absorbed energy of the pipe body shall meet the requirements in Clause E.5, SR20 (see also Table A.8 or Table C.8).

7.4 Process of manufacture

7.4.1 Processes requiring validation

Final operations performed during drill-pipe-body manufacturing that affect compliance as required in this International Standard (except chemical composition and dimensions) shall have their process validated.

The only process requiring validation is heat treatment.

7.4.2 General

Steel used for drill-pipe body furnished to this International Standard shall be made according to a fine-grained practice.

NOTE Steel made according to fine-grained practice contains one or more grain-refining elements, such as aluminium, niobium (columbium), vanadium or titanium in amounts intended to result in the steel having a fine, austenitic grain size.

Drill-pipe body shall be made from seamless pipe.

7.4.3 Heat treatment

Heat treatment shall be performed in accordance with a documented procedure. The procedure shall address the permissible number of re-heat-treatments. The heat-treatment procedure shall be selected by the manufacturer unless specified in the purchase agreement.

The drill-pipe body shall be heat treated over the full length after upsetting.

For grade E, the drill-pipe body shall be quenched and tempered or normalized and tempered or normalized.

For grades X, G and S, the drill-pipe body shall be quenched and tempered.

7.4.4 External coating

Unless otherwise specified in the purchase agreement, the drill-pipe body shall be given an external coating for protection from corrosion during transit. The coating shall be rated to protect the drill-pipe body for at least three months and it should be smooth, hard to the touch and with minimum sags.

7.5 Traceability

The drill-pipe body manufacturer shall establish and follow procedures for maintaining the heat identity of all drill-pipe body covered by this International Standard. Lot identity shall be maintained until all required lot tests are performed and conformance with specified requirements has been documented. The procedures shall provide means for tracing the drill-pipe body to the relevant heat and to the specified chemical, mechanical and test results.

Since a heat may be heat treated in more than one lot, there may be more than one set of mechanical test results for a heat.

7.6 Inspection and testing — General

7.6.1 Inspection and test-equipment calibration

The manufacturer shall determine and document the appropriate calibration frequency and procedures (including occurrences of out-of-calibration and the consequences on products) in order to be able to certify that all products conform to the requirements of this International Standard.

7.6.2 Heat-treatment lot

A lot shall consist of those lengths of drill-pipe body with the same specified dimensions and grade that are heat treated as part of a continuous operation (or batch), and are of a single heat of steel, or from different heats that are grouped according to a documented procedure that ensures that the appropriate requirements of this International Standard are met.

7.7 Testing of chemical composition

7.7.1 Heat analysis

Each heat of steel used in the manufacture of drill-pipe body shall be analysed to provide the results of quantitative determinations of phosphorus and sulfur plus any other elements used by the drill-pipe-body manufacturer to control mechanical properties.

7.7.2 Product analysis

Two tubular products from each heat used shall be analysed. These product analyses shall include the results of quantitative determinations of phosphorus and sulfur plus any other elements used by the manufacturer to control mechanical properties.

7.7.3 Test method

Chemical composition shall be determined by any of the procedures commonly used for determining chemical compositions, such as emission spectroscopy, X-ray emission, atomic absorption, combustion techniques or wet analytical procedures. The calibration methods used shall be traceable to established standards. In case of conflict, chemical analyses shall be made in accordance with ISO/TR 9769 or ASTM A751.

7.7.4 Re-test of product analysis

If the product composition of both lengths of tubular product representing the drill-pipe-body heat fail to conform to the specified requirements, at the manufacturer's option, either the heat shall be rejected or all the remaining lengths in the heat shall be tested individually for conformance to the specified requirements.

If only one of the two samples fails, at the manufacturer's option, either the heat shall be rejected or two re-check analyses shall be made on two additional lengths from the same heat. If both re-check analyses conform to the requirements, the heat shall be accepted, except for the length represented by the initial analysis that failed. If one or both of the re-check analyses fail, at the manufacturer's option, either the entire heat shall be rejected, or each of the remaining lengths shall be tested individually.

When individually testing the remaining lengths in any heat, it is necessary to analyse for only the non-conforming element or elements. Samples for re-check product analyses shall be taken in the same manner as specified for product-analysis samples. The results of all re-check product analyses shall be provided to the purchaser when specified in the purchase agreement.

7.8 Tensile tests

7.8.1 Procedures

The tensile test shall be performed at room temperature in accordance with ISO 6892 or ASTM A370.

7.8.2 Test equipment calibration

Tensile test machines shall have been calibrated within a period of 15 months preceding any test, in accordance with the procedures in ISO 7500-1 or ASTM E4. Extensometers shall have been calibrated within a period of 15 months preceding any test, in accordance with the procedures in ISO 9513 or ASTM E83. Retention of records shall be in accordance with 6.17.4 and Table A.9 or Table C.9.

7.8.3 Test specimens

Tensile specimens from the pipe body shall be either full-section specimens, strip specimens, or round-bar specimens, as shown in Figure B.8, at the option of the manufacturer. The type and size of specimen shall be reported.

Tensile specimens shall be removed from the pipe body after final heat treatment. Round-bar specimens shall be taken from the mid-wall. Strip specimens and round-bar specimens may be taken from any location around the circumference at the option of the manufacturer. All specimens shall represent the full wall thickness of the pipe body from which the specimen was cut, except for round-bar tensile specimens, and shall be tested without flattening.

When used, strip specimens shall be approximately 38 mm (1,5 in) wide in the gauge length if suitable curved-face testing grips are used or if the ends of the specimen are machined or cold flattened to reduce the curvature in the grip area. Otherwise, they shall be approximately 19 mm (0,75 in) wide for pipe smaller than label 1:4 and approximately 25 mm (1 in) wide for pipe label 1:4 and larger.

When round-bar specimens are used, a 12,7 mm (0,500 in) diameter round-bar specimen shall be used when the pipe size allows, and the 8,9 mm (0,350 in) diameter round-bar specimen shall be used for other sizes. Smaller round-bar specimens are not permitted.

7.8.4 Frequency of testing

The tensile-test frequency for the pipe body shall be as in Table A.10 or Table C.10.

No tensile test is required on the upset unless specified in the purchase agreement.

7.8.5 Heat control test

One tensile test shall be made as a control on each heat of steel used by the drill-pipe-body manufacturer. A record of such tests shall be available to the purchaser.

A heat control test may also be considered as a product test for the lot being tested.

7.8.6 Re-tests

If the initial tensile test fails to conform to the specified requirements, the manufacturer may elect to test two additional specimens from the same length and from approximately the same location. If both of the additional specimens pass, then the lot shall be accepted.

If one or both of the additional specimens fail to conform to the requirements, the manufacturer may elect to test three additional lengths from the same lot. If the specimens from all three lengths conform to the requirements, then the lot shall be accepted. If one or more of these specimens fail to conform to the requirement, the lot shall be rejected. Rejected lots may be re-heat-treated and tested as new lots.

7.8.7 Defective specimens

Specimens showing material imperfections or defective preparation, whether observed before or after testing, may be discarded, and replacements shall be considered as original specimens. Specimens shall not be judged defective simply because they fail to exhibit the minimum tensile requirements.

7.9 Charpy V-notch impact tests

7.9.1 Procedure

A test shall consist of a set of three longitudinal specimens taken from one location of a single piece. Charpy V-notch impact tests in accordance with ASTM A370 and ASTM E23 shall be conducted at a temperature of $21\text{ °C} \pm 3\text{ °C}$ ($70\text{ °F} \pm 5\text{ °F}$). For alternative standardized test temperatures, see Clause E.5, SR20, and PSL-3 in Table A.8 or Table C.8.

Tests conducted at any temperature lower than the specified temperature are acceptable provided the absorbed-energy requirements at the specified temperature are achieved.

Additional requirements for PSL-3 are in Annex G.

7.9.2 Specimen size and location

The impact-test specimen shall not be smaller than the largest size shown in Table A.11 or Table C.11 based on the specified pipe-body diameter (rounded to next smaller diameter if required) and the specified pipe-body wall thickness. The smallest specimen permitted shall be 10 mm × 5 mm.

The specimens shall be taken parallel to the axis of the pipe body with the notch oriented in a radial direction as shown in Figure B.9.

7.9.3 Frequency of testing

The impact test frequency for the pipe body shall be as in Table A.10 or Table C.10.

7.9.4 Heat control test

Charpy V-notch impact test specimens shall be taken after final heat treatment and shall conform to 7.9.2.

One impact test shall be made as a control on each heat of steel used by the drill-pipe-body manufacturer. A record of such tests shall be available to the purchaser.

A heat control test may also be considered as a product test for the lot being tested.

7.9.5 Re-test

If the requirements of 7.3.3 and 7.3.4, as applicable, are not met and not more than one specimen is below the minimum specimen absorbed-energy requirement, the manufacturer may elect either to reject the lot or to test three additional specimens from the same length and from approximately the same location. For all three of these specimens, the absorbed energy shall be equal to or greater than the minimum average absorbed energy in Table A.8 or Table C.8 or the lot shall be either rejected or re-tested as in the following paragraph.

If more than one specimen in the initial test is below the minimum specimen absorbed-energy requirement, then the manufacturer may elect either to reject the lot or to re-test an additional set of three specimens from each of three additional pipe bodies from the same lot. If these additional sets of specimens do not meet the initial test requirements, then the lot shall be rejected.

Rejected lots may be re-heat-treated and tested as new lots.

7.9.6 Defective specimens

Specimens showing material imperfections or defective preparation, whether observed before or after testing, may be discarded, and replacements shall be considered as original specimens. Specimens shall not be judged defective simply because they fail to exhibit the minimum absorbed-energy requirement.

7.10 Drill-pipe-body wall thickness

Each pipe body shall have the wall thickness verified in a helical or longitudinal path over the length of the pipe body, excluding end areas not covered by automated systems, in accordance with a documented procedure in order to verify that the requirements of this International Standard are met. The location of this verification process shall be at the discretion of the manufacturer. The inspection process shall take into account the pipe-making process.

The manufacturer shall also have a documented procedure demonstrating that the areas not covered by automated systems (particularly the transition areas between the pipe body and upset transition) comply with the requirements of this International Standard.

Prove-up may be made with a mechanical calliper or with a properly calibrated, manual, non-destructive testing device of appropriate accuracy according to a documented procedure. In case of dispute, measurement determined by use of the mechanical calliper shall govern.

The mechanical calliper shall be fitted with contact pins having circular cross sections of 6,4 mm ($1/4$ in) diameter. The end of the pin contacting the inside surface of the pipe body shall be rounded to a maximum radius of $d_{dp}/4$ with a minimum radius of 3,2 mm ($1/8$ in). The end of the pin contacting the outside surface of the pipe body shall be either flat or rounded to a radius of not less than 38 mm ($1\ 1/2$ in).

7.11 Drill-pipe-body length

The drill-pipe-body length shall be measured from end to end, unless otherwise specified in the purchase agreement. The accuracy of the length-measuring devices shall be $\pm 0,03$ m ($\pm 0,1$ ft). Drill-pipe-body length shall be measured in metres and hundredths of a metre (feet and tenths of a foot).

7.12 Internal upset

The manufacturer shall verify that the internal-upset length meets the requirements in Tables A.13 or A.14 or Tables C.13 or C.14, as applicable. Verification shall be at the frequency for tensile testing of drill-pipe bodies.

Verification shall be either by removal of coupons from the upset or by another documented method provided the manufacturer can demonstrate that the method ensures compliance with the specified requirements.

NOTE The d_{ou} on IEU drill-pipe (see Figure B.6) can be adjusted to accommodate the bores of individual tool joints, in which case the drill-pipe-body internal upset taper length, m_{iu} , is subject to change.

Additional requirements for PSL-2 and PSL-3 are in Annex G.

7.13 Internal profile

Each internal upset shall be visually examined for compliance with the requirements of 7.2.3. Questionable upsets shall be examined using the following method.

The internal upset inspection shall be made with a 90° hook-type tool (see Figure B.2). The contact pin shall be visually determined to be attached perpendicular to the handle. The contact-point radius shall not exceed the inside radius of the upset being inspected. Sharp edges on the contact point shall be removed (see contact point on Figure B.2). The 90° hook-type tool contact point should be maintained perpendicular to the longitudinal axis of the upset while the contact point is passed axially throughout the upset length. Pressure on the contact point shall be no greater than the pressure created by the weight of the 90° hook-type tool.

7.14 Straightness

All drill-pipe-body shall be visually examined. The straightness of questionably bent pipes or crooked extremities shall be measured (see Figure B.7) by one of the following methods:

- a) using a straight-edge or taut string (wire) from one end of the pipe body to the other end of the pipe body;
- b) using a minimum 1,8 m (6 ft) straight-edge shouldered on the pipe-body surface beyond the extent of the hooked extremity, or an equivalent method.

In case of dispute, the straight-edge measurement shall govern.

The chord or straight-edge shall be positioned to highlight the maximum deviation.

Deviation from the straight or chord height shall not exceed the requirements in 7.2.9. Measurements of the pipe-body deviation shall not be made in the plane of the upset or in the areas where the OD tolerances behind the drill-pipe-body external upset taper length, m_{eu} , apply (see 7.2.4).

7.15 Upset alignment

All drill-pipe-body shall be visually examined for upset alignment. Questionable upset alignment shall be measured using a saddle gauge from the outside diameter, D_{dp} , of pipe body to an area immediately behind the end of the upset (see Figure B.10). Other documented procedures may be used by agreement between purchaser and manufacturer.

Upset misalignment shall not exceed the limits in 7.2.10.

7.16 Mass determination

Each length of drill-pipe body shall be weighed separately to determine compliance with mass tolerance. The drill-pipe-body may be weighed non-upset or upset.

7.17 Imperfections and defects of drill-pipe body

7.17.1 General

Drill-pipe-body shall be free from defects as defined in this International Standard.

7.17.2 Surface-breaking pipe-body defects

Any imperfection on the outside or inside surface, of any orientation, shall be considered a defect if

- a) it is linear and deeper than 12,5 % of the specified wall thickness in the radial direction for grades E, X, G, or is linear and deeper than 5 % of the specified wall thickness in the radial direction for grade S, or
- b) it is linear or non-linear and results in a remaining wall thickness, above or below the imperfection, less than the minimum permissible wall thickness.

7.17.3 Surface-breaking upset defects

Any imperfection on the outside or inside surface, of any orientation, that is deeper than shown in Table A.15 or Table C.15, shall be considered a defect.

Sharp corners or changes in section that can cause a 90° tool to hang up shall be considered as defects.

7.17.4 Elephant hide

Elephant hide deeper than the minimum requirements in Table A.15 or Table C.15 shall be considered a defect.

7.17.5 Quench cracks

Quench cracks shall be considered defects.

7.17.6 Process control plan

The manufacturer, based on knowledge of the production process and the requirements of 7.18 and 7.19, shall apply a process control plan that ensures the fulfillment of the above requirements.

7.18 Visual inspection of drill-pipe body

7.18.1 General

The visual inspection shall be carried out by trained personnel with satisfactory visual acuity to detect surface imperfections. Documented lighting standards for visual inspection shall be established by the manufacturer. The minimum illumination level at the inspection surface shall be 500 lux (50 foot-candles).

NOTE Examples of visual acuity requirements can be found in ISO 11484 or ASNT SNT-TC-1A.

Visual end-area inspection shall be after all heat treatment.

If another method is applied with demonstrated capability of detecting defects as defined in 7.17, visual inspection is not required.

7.18.2 Coverage

Each drill-pipe-body shall be visually inspected for imperfections over the entire outside surface and the inside surface for a minimum distance of the length of upset including the run-out interval.

7.18.3 Disposition

Defects shall be completely removed by grinding or machining. All grinding shall be blended smooth. The dimensions after grinding shall comply with the requirements of 7.2.

7.18.4 Elephant hide

The external surface of the drill-pipe body shall be inspected for elephant hide in accordance with the requirements of Table A.15 or Table C.15. The external surfaces (see Figure B.6) that shall be examined for elephant hide are as follows:

- a) for EU, the areas of the upset, L_{EU} , the taper, m_{EU} , and the adjacent pipe body;
- b) for IU and IEU, the external surface areas over the upset, L_{IU} , the areas over the internal taper, m_{IU} , and the adjacent pipe body.

7.19 Non-destructive examination

7.19.1 General

All NDE operations (except visual inspection) to which reference is made in this International Standard shall be conducted by NDE personnel qualified in accordance with ISO 11484 or ASNT SNT-TC-1A.

When specified in the purchase agreement, the provisions for purchaser inspection of drill-pipe body and/or witnessing of NDE operations shall be in accordance with Annex D.

The inspections performed in accordance with 7.19, with the equipment calibrated to the specified reference indicators, should not be construed as assuring that the material requirements in 7.17 have been met.

The manufacturer shall determine the appropriate NDE equipment verification frequency to be able to certify that all products conform to the requirements of this International Standard.

If equipment, whose calibration or verification is required under the provisions of this International Standard, is subject to unusual or severe conditions such as can make its accuracy questionable, re-calibration or re-verification shall be performed before further use of the equipment. All material processed since the last successful calibration or verification shall be re-inspected.

The required NDE operations for the pipe body are in Table A.16 or Table C.16.

The NDE standards referenced in 7.19.3 are based on traditional, proven NDE methods and techniques practiced and adopted worldwide for the inspection of tubular products. However, other NDE methods or techniques that have demonstrated capability to detect defects as defined in 7.17 may be used. Records in accordance with 7.19.8 shall be maintained as in 7.22.4.

At the discretion of the manufacturer, the notches referenced in Table A.17 or Table C.17 may be oriented at an angle such that detection of defects typical of the manufacturing process is optimized. The technical justification for modification of the orientation shall be documented.

Additional requirements for PSL-2 and PSL-3 are in Annex G.

7.19.2 Coverage

Each drill-pipe body shall be inspected over the full length for the detection of imperfections (longitudinal and transverse) on the outside and inside surfaces. End areas not inspected by automated equipment shall be evaluated using magnetic-particle inspection or another inspection method that has demonstrated capability to detect defects as defined in 7.17. All required NDE operations, excluding wall-thickness verification, shall be carried out after final heat treatment and all rotary straightening operations.

7.19.3 Applicable standards

The inspections shall be performed, as a minimum, in accordance with the applicable standards (or equivalent standards) listed below:

- a) electromagnetic (flux leakage): ISO 9402 (longitudinal) and ISO 9598 (transverse) or ASTM E570;
- b) electromagnetic (eddy-current): ISO 9304 or ASTM E309;
- c) ultrasonic: ISO 9303 or ASTM E213 (longitudinal) and ISO 9305 or ASTM E213 (transverse);
- d) magnetic particle: ISO 13665 or ASTM E709.

7.19.4 Reference standards

Ultrasonic and electromagnetic inspection systems, except those for wall-thickness verification, shall use reference standards containing artificial reference indicators (notches) as shown in Table A.17 or Table C.17 and Figure B.11 to verify equipment response.

7.19.5 Documented procedures

The manufacturer may use any documented procedure to establish the reject threshold for ultrasonic or electromagnetic inspection, providing that the artificial reference indicators described in Table A.17 or Table C.17 are detected dynamically under normal operating conditions. Such detection capability shall be demonstrated dynamically. At the option of the manufacturer, this may be performed either on-line or off-line.

7.19.6 Inspection thresholds

Table A.17 or Table C.17 lists the reference indicators for establishing thresholds for sorting pipe that can contain defects as defined in 7.17. The reference indicators, used during automated ultrasonic or electromagnetic inspection, shall not be construed as being the defect sizes defined in 7.17, or be used by those other than the manufacturer as the only basis for rejection.

7.19.7 Automated inspection-system signal evaluation

All indications that are equal to or greater than the reject threshold shall be considered defects, unless it can be demonstrated that the imperfection causing the indication is not a defect as described in 7.17. Pipe with defects shall be given a disposition in accordance with 7.19.10.

7.19.8 NDE system capability records

The manufacturer shall maintain NDE system records verifying the capability of the system(s) in detecting the reference indicators used to establish the equipment test sensitivity.

The verification shall cover, as a minimum, the following criteria:

- a) coverage calculation (i.e. scan plan), including wall-thickness verification;
- b) capability for the intended wall thickness;
- c) repeatability;
- d) transducer orientation that provides detection of defects typical of the manufacturing process (see 7.17);
- e) documentation demonstrating that defects typical of the manufacturing process are detected using the NDE methods in 7.19.3;
- f) threshold-setting parameters.

In addition, the manufacturer shall maintain documentation relating to

- NDE system operating procedures,
- NDE equipment description,
- NDE personnel qualification information,
- dynamic test data demonstrating the NDE system/operation capabilities under production test conditions.

7.19.9 Evaluation of indications (prove-up)

The manufacturer has the option of either evaluating an indication that is equal to or greater than the reject threshold in accordance with this subclause or disposing of the indication as a defect in accordance with 7.19.10. Evaluations of indications shall be performed by level I certified inspectors under the supervision of level II or level III certified inspectors, or by level II or level III certified inspectors. Evaluation of indications shall be performed in accordance with written procedures.

When no imperfection is found in the area of the original indication and there is no explanation for the indication, then the pipe shall be rejected or, at the manufacturer's option, re-inspected over the full length either using the same inspection method or using ultrasonic inspection methods. At the manufacturer's option, the inspection equipment shall be adjusted either to the same sensitivity level as that used to perform the original inspection or to a reduced sensitivity that meets the specified requirements.

For the evaluation of an indicated imperfection, the depth shall be measured to determine whether it is a defect in accordance with 7.17. This measurement shall be performed as follows.

- a) The imperfection's depth may be measured using a mechanical measuring device (for instance, pit gauge, callipers, etc.). Removal of material by grinding or other means to facilitate measurement shall not reduce the remaining wall below the minimum permissible wall thickness. Abrupt changes in wall thickness caused by probe grinding shall be removed in accordance with 7.19.10.
- b) The imperfection's depth may be measured by ultrasonic technique(s) (time- and/or amplitude-based, or other capable techniques). Verification of the ultrasonic technique(s) shall be documented and shall show the capability to detect imperfections with the size stated in 7.17, or larger.
- c) If the purchaser and manufacturer do not agree on the evaluation test results, either party may require destructive evaluation of the material; after which, accountability shall be as described in Clause D.4.
- d) Imperfections that have been evaluated and found to be defects shall be given a disposition in accordance with 7.19.10.

7.19.10 Disposition of defects

Imperfections that satisfy the material requirements and are less than the defect size stated in 7.17 may remain in the drill-pipe-body.

Drill-pipe-body containing quench cracks shall be rejected except that, when the quench cracks are confined to the end of the upset, the end may be cut back in accordance with a documented procedure.

Repair welding is not permitted.

Drill-pipe-body containing defects, except for quench cracks, shall be given one of the following dispositions.

- a) Grinding or machining: Defects shall be completely removed by grinding or machining, provided the remaining wall thickness is within specified limits. Grinding shall be carried out in such a way that the dressed area blends smoothly into the contour of the tube. When the depth of grind exceeds 10 % of the specified wall thickness, the remaining wall thickness shall be verified in accordance with 7.10. After removal of the defect, the affected area shall be re-inspected to verify that the defect was completely removed. The re-inspection shall be either
 - 1) by the same inspection unit that performed the initial inspection, at the same sensitivity, or
 - 2) by another NDE method, or combination of methods, that demonstrates equal or greater sensitivity to the original NDE.

When method 2) above is used, the NDE method (or combination of methods) shall be documented and shall demonstrate equal or greater sensitivity than the original non-destructive examination. In addition, method 2) shall address the possibility that there can be other coincident defects in the affected area.

The removal of imperfections (including elephant hide) from the drill-pipe-body by grinding or machining more than 60 % of the circumference of the drill-pipe body shall not reduce the outside diameter below the specified minimum outside diameter.

- b) Cutting off.
- c) Rejection.

7.20 Marking

7.20.1 General

Marking of the drill-pipe-body shall be carried out by the drill-pipe-body manufacturer, as in 7.20.2, when this component is ordered as an individual part. When the drill-pipe-body is manufactured by the drill-pipe manufacturer, marking of the drill-pipe body may be done in a way different from that in 7.20.2 provided the requirements for traceability are maintained.

Additional markings, paint-stencilling or die stamping may be applied, including those for applicable compatible standards, at the option of the manufacturer or as specified by the purchaser. Die stamping shall be located only on the upset of the drill-pipe-body. Markings shall not overlap and shall be applied in such a manner as not to damage the drill-pipe body.

7.20.2 Paint-stencilled marking sequence

A paint-stencilled marking shall be placed on the outside surface of each length of drill-pipe-body starting not less than 0,6 m (24 in) from either end of the drill-pipe-body. The sequence of paint-stencilled markings on the drill-pipe-body shall be as follows:

- a) The letters "DPB";

NOTE These letters indicate that this marking relates to the drill-pipe-body.

- b) drill-pipe-body manufacturer's name or mark;
- c) "ISO 11961" and/or "Specification 5DP", as applicable; marking to indicate compliance with API Spec 5DP is at the manufacturer's option or as specified in the purchase agreement;
- d) API monogram marking requirements (see Annex H), if applicable;
- e) date of manufacture (month and year).

The date of manufacture shall be a three- or four-digit number consisting of a one- or two-digit number indicating the month followed by the last two digits of the year in which the markings of Clause 7 are completed. Products manufactured in accordance with this edition of ISO 11961 during the period of overlap of application with the previous edition (see Foreword) may be identified by "00" as the overlap period designation rather than the month;

- f) "UF" if upset dimensions are different from those in Table A.13 or A.14 or Table C.13 or C.14;
- g) size designation (label 1);
- h) mass designation (label 2);
- i) grade of drill-pipe body;
- j) SR information;
- k) L2 or L3 (indicating PSL-2 or PSL-3), as applicable;
- l) traceability code (for traceability requirements, see 7.5).

EXAMPLE Label 1: 2-³/₈, label 2: 6.65, grade E drill-pipe-body manufactured by company ZZ with traceability code YYYY in July 2007 and with special upset dimensions is paint stencilled as follows:

DPB ZZ ISO 11961 707 UF 2-3/8 6.65 E YYYY.

7.21 Minimum facility requirements for drill-pipe-body manufacturer

The drill-pipe-body manufacturer shall operate upsetting facilities and/or heat treatment facilities capable of heat treating full lengths of drill-pipe body and shall possess suitable equipment for, and be responsible for, weighing and marking the drill-pipe-body. If the drill-pipe-body manufacturer purchases upset pipe or subcontracts the upsetting or the heat treatment, the conduct of such operations shall be controlled and monitored by the drill-pipe-body manufacturer in accordance with a documented procedure.

The drill-pipe-body manufacturer shall have facilities for conducting all required tests and inspections, or any of these tests or inspections may be provided by a subcontractor and may be located offsite. In the event that a subcontractor performs any of these services, the conduct of such inspections and tests shall be controlled and monitored by the drill-pipe-body manufacturer in accordance with a documented procedure.

7.22 Documentation requirements

7.22.1 Certificate of inspection

The drill-pipe-body manufacturer shall provide a certificate of inspection containing the following data, as applicable, for each order item specified in the purchaser agreement:

- a) ISO International Standard (or equivalent specification) and revision date thereof, to which the drill-pipe body was manufactured;
- b) label 1, label 2, upset configuration, grade of drill-pipe-body, type of heat treatment, length and tolerances and any other special requirements specified in the purchase agreement;
- c) statement that the drill-pipe-body was manufactured, inspected and tested in accordance with, and is in compliance with, this International Standard;
- d) chemical analyses (heat, product and re-check, as applicable) showing the mass per cent of all elements whose limits or reporting requirements are stipulated in this International Standard and any other elements used by the manufacturer to control the mechanical properties;
- e) test data for all tensile tests required by this International Standard, including yield strength, tensile strength and elongation; the type and size of specimens shall be shown;
- f) where impact testing is required by the International Standard, reported data for each test shall include
 - the absorbed-energy requirement,
 - the size, location and orientation of the test specimens,
 - the specified temperature at which the test was performed,
 - the absorbed energy measured for each test specimen,
 - the average absorbed energy,
 - the percent shear area for each test specimen (for information only);
- g) results of any other supplemental testing requirements specified in the purchase agreement.

7.22.2 Tally list

The drill-pipe-body manufacturer shall provide the purchaser with a tally list providing the length, L_{pe} , for each drill-pipe-body.

7.22.3 Electronic data interchange

The standard documents (see 7.22.1 and 7.22.2) printed from or used in electronic form from an electronic data interchange (EDI) transmission shall be regarded as having the same validity as a counterpart printed in the drill-pipe-body manufacturer's facility. The content of the EDI-transmitted document shall meet the requirements of this International Standard and conform to any existing EDI agreement between the purchaser and the drill-pipe-body manufacturer.

7.22.4 Retention of records

Table A.9 or Table C.9 specifies records which shall be retained. Such records shall be retained by the drill-pipe-body manufacturer and shall be available to the purchaser on request for a period of five years after the date of purchase from the drill-pipe-body manufacturer.

8 Requirements for tool joints

8.1 Information to be supplied when placing orders for tool joints

8.1.1 When placing orders for tool joints to be manufactured in accordance with this International Standard, the purchaser shall specify the following on the purchase agreement:

Requirements	Reference
Document number(s)	ISO 11961 or API Spec 5DP
Quantity	
Drawing of the tool-joint pin, including any necessary details	Figure B.12
Drawing of the tool-joint box, including any necessary details	Figure B.12
Delivery date and shipping instructions	
Inspection by purchaser	Annex D
Documentation	8.15

8.1.2 The purchaser shall also specify in the purchase agreement his requirements concerning the following stipulations, which are optional with the purchaser:

Requirements	Reference
Special surface treatment	8.4.5
Tool-joint break-in	8.4.6
Hard banding: type, location, dimensions and acceptance criteria	8.4.7

NOTE Hard banding reduces the length of tool-joint outside diameter available for tong placement.

Thread-protector type	8.4.8
Marking requirements	8.13
Alternative requirements for impact testing	Clause E.5, SR20
PSL-2 or PSL-3	Annex G

8.2 Dimensional requirements

8.2.1 General

All dimensions shown without tolerances are related to the basis for design and are not subject to measurement to determine acceptance or rejection of the product. Tool-joint dimensions that are not specified in this International Standard are optional with the manufacturer unless otherwise specified in the purchase agreement.

8.2.2 Configuration

Tool-joint configuration shall correspond to Figure B.12.

8.2.3 Tool-joint type

Tool joints shall be produced with the rotary shouldered connections in Table A.1 or Table C.1 except as provided by 8.2.5.

8.2.4 Dimensions

Tool joints shall conform to the dimensions and the tolerances in Table A.1 or Table C.1 or in the purchase agreement. See Figure B.12.

The drill-pipe weld neck diameter, D_{te} , at the elevator shoulder, in Table A.1 or Table C.1 and Figure B.1, applies to the finished product after the tool joint is welded to the drill-pipe body. Dimensions prior to welding shall be specified by the drill-pipe manufacturer.

The tool-joint-box inside diameter is at the drill-pipe manufacturer's discretion but shall not be less than the pin internal diameter, d_p (see Figure B.1).

The outside and inside diameters, D and d_p , respectively, in Table A.1 or Table C.1 result in a drill-pipe torsion-strength ratio of 0,8 or greater. Other OD and ID tool joints, such as in combination strings or tapered strings, may be specified in the purchase agreement but the drill-pipe torsion-strength ratio may be different.

8.2.5 Rotary shouldered connection

Rotary shouldered connections shall conform to the dimensions and tolerances in ISO 10424-2 or API Spec 7-2. Right-hand thread connections shall be considered standard. However, when specified in the purchase agreement, other connections are permitted. In this case, dimensions, tolerances and performance ratings shall be agreed between the purchaser and manufacturer.

8.3 Material requirements

8.3.1 Chemical composition

The chemical composition shall be as in Table A.4 or Table C.4.

8.3.2 Tensile requirements

The tool joint shall conform to the requirements in Table A.5 or Table C.5.

The yield strength of the pin shall be determined using the 0,2 % offset method.

NOTE Compliance with the requirements for tensile properties for the tool-joint box is verified by hardness testing.

Additional requirements for PSL-3 are in Annex G.

8.3.3 Hardness

The hardness for the tool-joint box shall be in the range 285 HBW to 341 HBW.

This requirement shall not apply to the through-wall hardness variation requirements in Clause G.3.

Additional requirements for PSL-3 are in Annex G.

8.3.4 Charpy V-notch absorbed-energy requirements

The minimum absorbed-energy requirements shall be as in Table A.8 or Table C.8. In addition, not more than one impact specimen shall exhibit an absorbed energy below the minimum average absorbed-energy requirement, and in no case shall an individual impact specimen exhibit an absorbed energy below the minimum specimen absorbed-energy requirement.

Additional requirements for PSL-3 are in Annex G.

8.4 Process of manufacture

8.4.1 Processes requiring validation

Final operations performed during tool-joint manufacturing that affect attribute compliance as required in this International Standard (except chemical composition and dimensions) shall have their process validated.

Those processes requiring validation are

- heat treatment, and
- hard banding, if applicable.

8.4.2 Material

Tool joints shall be manufactured from forgings or hot-rolled steel.

8.4.3 Heat treatment

Heat treatment shall be performed according to a documented procedure. The procedure shall address the permissible number of re-heat-treatments.

Tool joints shall be quenched and tempered.

8.4.4 Threading

Unless otherwise specified in the purchase agreement, tool-joint thread connections including benchmarks shall be manufactured in accordance with ISO 10424-2 or API Spec 7-2.

8.4.5 Surface treatment to minimize galling

Surface treatment of threads to minimize galling, such as phosphating, copper plating or any other appropriate method, shall be applied. Unless otherwise specified in the purchase agreement, the method is at the option of the manufacturer. The surface treatment shall be performed in accordance with a documented procedure.

8.4.6 Break-in procedure

When specified in the purchase agreement, tool-joint break-in shall be performed in accordance with a documented procedure.

8.4.7 Hard banding

Hard banding of tool joints may be agreed between the purchaser and the manufacturer. The type of hard banding, location, dimensions and tolerances shall be specified in the purchase agreement and the application shall be carried out in accordance with a documented procedure.

8.4.8 Thread protection

The tool-joint manufacturer shall be responsible for thread protection during storage and shipment to the purchaser, unless otherwise stipulated in the purchase agreement.

8.5 Traceability

The tool-joint manufacturer shall establish and follow procedures for maintaining heat identity of all tool joints covered by this International Standard. Lot identity shall be maintained until all required lot tests are performed and conformance with specification requirements has been documented. The procedures shall provide means for tracing the tool joint to the relevant heat and to the specified chemical, mechanical and test results.

NOTE Since a heat can be heat treated in more than one lot, there can be more than one set of mechanical test results for a heat.

8.6 Inspection and testing — General

8.6.1 Inspection and test-equipment calibration

The manufacturer shall determine and document the appropriate calibration frequency and procedures (including occurrences of out-of-calibration and the consequences on products) in order to be able to certify that all products conform to the requirements of this International Standard.

8.6.2 Heat-treatment lot

A lot shall consist of those pin or box tool joints with the same specified dimensions that are heat treated as part of a continuous operation (or batch), and are of a single heat of steel, or from different heats that are grouped according to a documented procedure that ensures that the appropriate requirements of this International Standard are met.

8.7 Testing of chemical composition

8.7.1 General

For tool joints, the analyses shall be made by the steel manufacturer or tool-joint manufacturer and shall be taken from material in finished, forged, tubular or bar form.

8.7.2 Product analyses

Each heat of steel used in the manufacture of tool-joints shall be analysed to provide the results of quantitative determinations of phosphorus and sulfur plus any other elements used by the manufacturer to control mechanical properties.

8.7.3 Test method

Chemical composition shall be determined by any of the procedures commonly used for determining chemical compositions, such as emission spectroscopy, X-ray emission, atomic absorption, combustion techniques or wet analytical procedures. The calibration methods used shall be traceable to established standards. In case of conflict, chemical analyses shall be made in accordance with ISO/TR 9769 or ASTM A751.

8.8 Tensile tests

8.8.1 Procedures

Tensile tests shall be performed at room temperature in accordance with ISO 6892 or ASTM A370.

8.8.2 Test-equipment calibration

Tensile test machines shall have been calibrated within a period of 15 months preceding any test, in accordance with the procedures in ISO 7500-1 or ASTM E4. Extensometers shall have been calibrated within a period of 15 months preceding any test, in accordance with the procedures in ISO 9513 or ASTM E83. Retention of records shall be in accordance with 6.17.4 and Table A.9 or Table C.9.

8.8.3 Test specimens

Tensile specimens shall be removed from the pin tool joint as in Figure B.13 after final heat treatment. Specimens may be taken from semi-finished products (that is, before threading, machining or hard banding operations).

By agreement between the purchaser and manufacturer, tensile tests shall also be undertaken on box tool joints. In such cases, details of testing shall also be agreed.

The test shall be conducted using a 12,7 mm (0,500 in) diameter round specimen.

If the pin section at the specified location is not sufficient to obtain a tensile specimen of 12,7 mm (0,500 in) diameter, an 8,9 mm (0,350 in) or 6,4 mm (0,250 in) diameter specimen may be used. The largest possible diameter specimen shall be used.

If the pin section at the specified location is not sufficient to obtain a 6,4 mm (0,250 in) diameter specimen [25 mm (1 in) gauge length], the tensile test is not required and a hardness test shall be carried out in accordance with 8.9.

8.8.4 Frequency of test

The tensile test frequency for the pin tool joint shall be as in Table A.10 or Table C.10.

Additional requirements for PSL-3 are in Annex G.

8.8.5 Heat control tensile tests

One tensile test shall be made as a control test from each heat of steel used by the manufacturer for the production of tool-joint pins under this International Standard. A record of such tests shall be available to the purchaser.

A heat control test may also be considered as a product test for the lot being tested.

8.8.6 Re-test

If the initial tensile test fails to conform to the specified requirements, the manufacturer may elect to test two additional specimens from the same piece. If both of the additional specimens pass, the lot shall be accepted.

If one or both of the additional specimens fail to conform to the requirements, the manufacturer may elect to test three additional pin tool joints from the same lot. If the specimens from all three pin tool joints conform to the requirements, the lot shall be accepted. If one or more of the specimens fails to conform to the requirement, the lot shall be rejected. Rejected lots may be re-heat-treated and tested as new lots.

8.8.7 Defective specimens

Specimens showing material imperfections or defective preparation, whether observed before or after testing, may be discarded, and replacements shall be considered as original specimens. Specimens shall not be judged defective simply because they fail to exhibit the minimum tensile requirements.

8.9 Hardness tests

8.9.1 Procedure

Hardness tests shall be performed at room temperature in accordance with ISO 6506-1 or ASTM E10 for Brinell hardness tests.

8.9.2 Test specimen

The specimen shall be removed from the box tool joint as in Figure B.13 after final heat treatment. The specimen may be taken on semi-finished product (that is, before threading, machining or hard banding operations).

If the specified location for the pin-tool-joint tensile test is not sufficient to obtain an acceptable tensile test specimen (see 8.8.3), a hardness test shall be performed on the pin tool joint as in Figure B.13.

8.9.3 Frequency of testing

The hardness-test frequency for the box tool joint shall be as in Table A.10 or Table C.10.

When hardness testing is required for pin tool joints due to insufficient material for tensile testing, the hardness testing of the pin tool joint shall be performed at the tensile testing frequency in Table A.10 or Table C.10.

8.9.4 Heat control hardness tests

One hardness test shall be made as a control test from each heat of steel used by the manufacturer for the production of tool-joint boxes (and, when necessary, pins) under this International Standard. A record of such tests shall be available to the purchaser.

A heat control test may also be considered as a product test for the lot being tested.

8.9.5 Re-tests

Any tool joint representing a lot that fails to meet the hardness requirements may be re-tested. Two additional tests shall be made approximately three impression diameters each side of the original test location. If both of the additional tests meet the requirements, the lot shall be accepted.

If one or both of the additional tests fail to conform to the requirements, the manufacturer may elect to test three additional tool joints from the same lot. If the tests on all three tool joints conform to the requirements, the lot shall be accepted. If one or more of the tests fails to conform to the requirement, the lot shall be rejected. Rejected lots may be re-heat-treated and tested as new lots.

8.10 Charpy V-notch impact tests

8.10.1 Procedures

A test shall consist of a set of three longitudinal specimens taken from a tool joint. Charpy V-notch impact tests as in ASTM A370 and ASTM E23 shall be conducted at a temperature of $21\text{ °C} \pm 3\text{ °C}$ ($70\text{ °F} \pm 5\text{ °F}$). For an alternative standardized test temperature, see Clause E.5, SR20, and PSL-3 in Table A.8 or Table C.8.

Tests conducted at a temperature lower than the specified temperature are acceptable provided the absorbed-energy requirements at the specified temperature are achieved.

Additional requirements for PSL-3 are in Annex G.

8.10.2 Specimen size and location

Charpy V-notch impact specimens shall be removed from the tool joint as in Figure B.13 after final heat treatment. Specimens may be taken from semi-finished product (that is, before threading, machining or hard banding operations).

The impact-test specimen shall not be smaller than the largest size shown in Table A.11 or Table C.11 based on the minimum material diameter (rounded to the next smaller diameter, if required) and the wall thickness in the test area. The smallest specimen permitted shall be 10 mm × 5 mm.

The specimens shall be taken parallel to the axis of the tool joint with the notch oriented in a radial direction as in Figure B.13.

8.10.3 Frequency of testing

The Charpy V-notch impact-test frequency shall be as in Table A.10 or Table C.10.

Additional requirements for PSL-3 are in Annex G.

8.10.4 Heat control test

One impact test shall be made as a control on each heat of steel used by the tool-joint manufacturer. A record of such tests shall be available to the purchaser.

A heat control test may also be considered as a product test for the lot being tested.

8.10.5 Re-test

If the requirements of 8.3.4 are not met and not more than one specimen is below the minimum specimen absorbed-energy requirement, then the manufacturer may elect either to reject the lot or to re-test a set of three additional specimens from the same test piece. For all three of these specimens, the absorbed energy shall be equal to or greater than the minimum average absorbed energy in Table A.8 or Table C.8 or the lot shall be rejected. If insufficient material remains for the re-test specimens to be obtained from the original sample, then it is permitted to obtain specimens from a tool joint from the same lot.

If more than one specimen in the initial test is below the minimum specimen absorbed-energy requirement then the manufacturer may elect either to reject the lot or to re-test an additional set of three specimens from each of three additional tool joints from the same lot. If these additional sets of specimens do not meet the initial test requirements, then the lot shall be rejected.

Rejected lots may be re-heat-treated and tested as a new lot.

8.10.6 Defective specimens

Specimens showing material imperfections or defective preparation, whether observed before or after testing, may be discarded, and replacements shall be considered as original specimens. Specimens shall not be judged defective simply because they fail to exhibit the minimum absorbed-energy requirement.

8.11 Imperfections and defects

8.11.1 General

Tool joints shall be free from defects as defined in this International Standard. Die stamping shall not be considered a defect.

8.11.2 Surface breaking defects

In the threads, on the coincident opposite surfaces (that is, the outside surface of the internally threaded member and the inside surface of the externally threaded member) or on the ends of the threaded area, any imperfection shall be considered a defect.

On the surfaces not described above,

- any linear imperfection shall be considered a defect;
- non-linear imperfections that exceed 25 % of the circumference or exceed 3,2 mm (0.125 in) in depth shall be considered defects.

8.11.3 Quench cracks

Quench cracks shall be considered defects.

8.11.4 Process control plan

The manufacturer, based on knowledge of the production process and the requirements of 8.11, shall apply a process control plan that ensures that the above requirements are fulfilled.

8.12 Non-destructive examination

8.12.1 General

All NDE operations (except visual inspection) to which reference is made in this International Standard shall be conducted by NDE personnel qualified in accordance with ISO 11484 or ASNT SNT-TC-1A.

When specified in the purchase agreement, the provisions for purchaser inspection of tool joints and/or witnessing of NDE operations shall be in accordance with Annex D.

The inspections performed in accordance with 8.12 should not be construed as assuring that the material requirements in 8.11 have been met.

The manufacturer shall determine the appropriate NDE equipment verification frequency in order to be able to certify that all products conform to the requirements of this International Standard.

If equipment whose calibration or verification is required under the provisions of this International Standard is subject to unusual or severe conditions such as can make its accuracy questionable, re-calibration or re-verification shall be performed before further use of the equipment.

8.12.2 Wet magnetic-particle inspection

After heat treatment and threading, each tool joint shall be inspected for longitudinal and transverse imperfections on the inside and outside surfaces by the wet magnetic-particle method in accordance with ISO 13665 or ASTM E709. Inspection shall be performed in accordance with a written procedure. The wet-particle concentration shall be checked every 8 h or each shift change. The minimum black-light intensity at the examination surface shall not be less than 1 000 $\mu\text{w}/\text{cm}^2$.

8.12.3 Disposition of defects

Defects shall be cause for rejection or shall be completely removed by grinding or machining in accordance with a written procedure, provided the requirements of 8.2 are met. All grinding shall be blended smooth. After grinding or machining to remove defects, the tool joint shall be re-inspected by the same method that detected the defect in order to verify removal of the defect.

8.13 Marking

8.13.1 General

Marking of the tool joint shall be carried out by the tool-joint manufacturer as in 8.13.2 when this component is ordered as an individual part. When the tool joint is manufactured by the drill-pipe manufacturer, marking of the tool joint may be done in a way different from that in 8.13.2, provided that the requirements for traceability are maintained.

Additional markings may be applied, including those for applicable compatible standards, at the option of the manufacturer or as specified by the purchaser. Marking of the tool joint with grooves and flats (see 6.15.5) may be applied at any time during the production process of the tool joint.

Markings shall not overlap and shall be applied in such a manner as not to damage the tool joint.

8.13.2 Die stamp marking

The tool-joint outside diameter shall be die stamped with the following:

- a) tool-joint manufacturer's name or mark;
- b) tool-joint designation (RSC type or, for connections not in Table A.1 or Table C.1, designation as specified by the manufacturer); see Table A.1 or Table C.1;
- c) "ISO 11961" and/or "Specification 5DP", as applicable. Marking to indicate compliance with API Spec 5DP is at the manufacturer's option or as specified in the purchase agreement;
- d) API monogram marking requirements (see Annex H), if applicable;
- e) date of manufacture (month and year).

The date of manufacture shall be a three- or four-digit number consisting of a one- or two-digit number indicating the month followed by the last two digits of the year in which the markings of Clause 8 are completed. Products manufactured in accordance with this edition of ISO 11961 during the period of overlap of application (see Foreword) with the previous edition may be identified by "00" as the overlap period designation rather than the month;

- f) SR20, if applicable;
- g) L2 or L3 (indicating PSL-2 or PSL-3), as applicable;
- h) traceability code (for traceability requirements, see 8.5).

EXAMPLE NC50 tool joint manufactured by ZZ in August of 2007 in accordance with this International Standard with traceability code YYYY is die stamped as follows (one or more lines):

ZZ NC50 ISO 11961 807 YYYY

8.14 Minimum facility requirements for tool-joint manufacturers

The tool-joint manufacturer shall operate facilities for heat treating and/or threading tool joints and shall possess, and be responsible for, suitable equipment for marking the tool joint. If the tool-joint manufacturer purchases heat-treated material or subcontracts the heat treatment or the threading, the conduct of such operations shall be controlled and monitored by the tool-joint manufacturer in accordance with a documented procedure.

The tool-joint manufacturer shall either have facilities for conducting all required tests and inspections, or any of these tests or inspections may be provided by a subcontractor and may be located offsite. In the event that a subcontractor performs any of these services, the conduct of such inspections and tests shall be controlled and monitored by the tool-joint manufacturer in accordance with a documented procedure.

8.15 Documentation requirements for tool joints

8.15.1 Certificate of inspection

The tool-joint manufacturer shall provide a certificate of inspection containing the following data, as applicable, for each item specified in the purchase agreement:

- a) ISO International Standard number (or equivalent specification) and revision date thereof, to which the tool joints were manufactured;
- b) tool-joint OD, tool-joint ID, length of pin/box outside diameter;
- c) RSC type, type of heat treatment and any other special requirements specified in the purchase agreement
- d) statement that the tool joint has been manufactured, inspected and tested in accordance with, and is in compliance with, this International Standard;
- e) chemical analysis showing the mass per cent of all elements whose limits or reporting requirements are stipulated in this International Standard and any other elements used by the manufacturer to control the mechanical properties;
- f) test data for all tensile tests required by this International Standard, including yield strength, tensile strength and elongation; the type and size of specimens shall be shown;
- g) where impact testing is required by the International Standard, reported data for each test shall include
 - the absorbed-energy requirement,
 - the size, location and orientation of the test specimens,
 - the specified temperature at which the test was performed,
 - the absorbed energy measured for each test specimen,
 - the average absorbed energy,
 - the percent shear area for each test specimen (for information only);
- h) hardness test results (including test type and criteria, and specimen location and orientation);
- i) results of any other supplemental testing requirements specified in the purchase agreement.

8.15.2 Electronic data interchange

The standard documents printed from or used in electronic form from an electronic data interchange (EDI) transmission shall be regarded as having the same validity as a counterpart printed in the tool-joint manufacturer's facility. The content of the EDI-transmitted document shall meet the requirements of this International Standard and conform to any existing EDI agreement between the purchaser and the tool-joint manufacturer.

8.15.3 Retention of records

Table A.9 or Table C.9 specifies records which shall be retained. Such records shall be retained by the tool-joint manufacturer and shall be available to the purchaser on request for a period of five years after the date of purchase from the tool-joint manufacturer.

Annex A
(normative)

Tables in SI units

Table A.1 — Drill-pipe list, main dimensions and mass

Designations ^a				Pipe-body OD	Pipe wall thickness	Drill-pipe weld neck	Tool joint				RSC bevel dia.	Approx. mass ^c	
Label 1	Label 2	Grade	Upset type				RSC type ^d	OD	Pin ID	Pin OD length			Box OD length
1	2	3	4	5	D_{dp} mm	t mm	D_{te}^b mm	D mm	d_p mm	L_{pb} mm	L_b mm	D_t mm	w_{dp} kg/m
					See Table A.2	-12,5 %	max.	± 0,8	+0,4 -0,8	± 6,4	± 6,4	± 0,4	Calculated
					6	7	8	9	10	11	12	13	14
Internal upset, IU													
4	14.00	E	IU	NC40	101,60	8,38	106,4	133,4	71,4	177,80	254,00	127,40	22,42
4	14.00	X	IU	NC40	101,60	8,38	106,4	133,4	68,3	177,80	254,00	127,40	22,76
4	14.00	G	IU	NC40	101,60	8,38	106,4	139,7	61,9	177,80	254,00	127,40	23,61
4	14.00	S	IU	NC40	101,60	8,38	106,4	139,7	50,8	177,80	254,00	127,40	24,03
4-1/2	13.75	E	IU	NC46	114,30	6,88	119,1	152,4	85,7	177,80	254,00	145,26	22,50
2-3/8	6.65	E	EU	NC26	60,32	7,11	65,1	85,7	44,5	177,80	203,20	82,95	10,45
2-3/8	6.65	X, G	EU	NC26	60,32	7,11	65,1	85,7	44,5	177,80	203,20	82,95	10,58
2-7/8	10.40	E	EU	NC31	73,02	9,19	81,0	104,8	54,0	177,80	228,60	100,41	16,25
2-7/8	10.40	X, G	EU	NC31	73,02	9,19	81,0	104,8	50,8	177,80	228,60	100,41	16,50
2-7/8	10.40	S	EU	NC31	73,02	9,19	81,0	111,1	41,3	177,80	228,60	100,41	17,19
3-1/2	9.50	E	EU	NC38	88,90	6,45	98,4	120,7	68,3	203,20	266,70	116,28	15,77
3-1/2	13.30	E	EU	NC38	88,90	9,35	98,4	120,7	68,3	203,20	266,70	116,28	20,77
3-1/2	13.30	X	EU	NC38	88,90	9,35	98,4	127,0	65,1	203,20	266,70	116,28	21,76
3-1/2	13.30	G	EU	NC38	88,90	9,35	98,4	127,0	61,9	203,20	266,70	116,28	21,90
3-1/2	13.30	S	EU	NC38	88,90	9,35	98,4	127,0	54,0	203,20	266,70	116,28	22,22
3-1/2	15.50	E	EU	NC38	88,90	11,40	98,4	127,0	65,1	203,20	266,70	116,28	24,67
3-1/2	15.50	X	EU	NC38	88,90	11,40	98,4	127,0	61,9	203,20	266,70	116,28	25,07
3-1/2	15.50	G	EU	NC38	88,90	11,40	98,4	127,0	54,0	203,20	266,70	116,28	25,38
3-1/2	15.50	S	EU	NC40	88,90	11,40	98,4	139,7	57,2	203,20	266,70	127,40	26,19

Table A.1 (continued)

Designations ^a				Pipe body OD	Pipe wall thickness	Drill-pipe weld neck	Tool joint				RSC bevel dia.	Approx. mass ^c	
Label 1	Label 2	Grade	Upset type				RSC type ^d	OD	Pin ID	Pin OD length			Box OD length
1	2	3	4	5	D_{dp} mm See Table A.2	t mm -12,5 %	D_{te}^b mm max.	D mm $\pm 0,8$	d_p mm $+0,4$ $-0,8$	L_{pb} mm $\pm 6,4$	L_b mm $\pm 6,4$	D_f mm $\pm 0,4$	kg/m Calculated
External-upset (EU)													
4	14.00	E	EU	NC46	101,60	8,38	114,3	152,4	82,6	177,80	254,00	145,26	23,67
4	14.00	X, G	EU	NC46	101,60	8,38	114,3	152,4	82,6	177,80	254,00	145,26	24,12
4	14.00	S	EU	NC46	101,60	8,38	114,3	152,4	76,2	177,80	254,00	145,26	24,46
4-1/2	13.75	E	EU	NC50	114,30	6,88	127,0	168,3	95,3	177,80	254,00	153,99	23,65
4-1/2	16.60	E	EU	NC50	114,30	8,56	127,0	168,3	95,3	177,80	254,00	153,99	27,51
4-1/2	16.60	X, G	EU	NC50	114,30	8,56	127,0	168,3	95,3	177,80	254,00	153,99	28,07
4-1/2	16.60	S	EU	NC50	114,30	8,56	127,0	168,3	88,9	177,80	254,00	153,99	28,47
4-1/2	20.00	E	EU	NC50	114,30	10,92	127,0	168,3	92,1	177,80	254,00	153,99	32,93
4-1/2	20.00	X, G	EU	NC50	114,30	10,92	127,0	168,3	88,9	177,80	254,00	153,99	33,63
4-1/2	20.00	S	EU	NC50	114,30	10,92	127,0	168,3	76,2	177,80	254,00	153,99	34,34
4-1/2	16.60	E	IEU	NC46	114,30	8,56	119,1	158,8	82,6	177,80	254,00	145,26	27,36
4-1/2	16.60	X, G	IEU	NC46	114,30	8,56	119,1	158,8	76,2	177,80	254,00	145,26	27,73
4-1/2	16.60	S	IEU	NC46	114,30	8,56	119,1	158,8	69,9	177,80	254,00	145,26	28,04
4-1/2	20.00	E	IEU	NC46	114,30	10,92	119,1	158,8	76,2	177,80	254,00	145,26	32,94
4-1/2	20.00	X	IEU	NC46	114,30	10,92	119,1	158,8	69,9	177,80	254,00	145,26	33,69
4-1/2	20.00	G	IEU	NC46	114,30	10,92	119,1	158,8	63,5	177,80	254,00	145,26	33,97
4-1/2	20.00	S	IEU	NC46	114,30	10,92	119,1	158,8	57,2	177,80	254,00	145,26	34,23

Table A.1 (continued)

Designations ^a				Pipe body OD	Pipe wall thickness	Drill-pipe weld neck	Tool joint				RSC bevel dia.	Approx. mass ^c
Label 1	Label 2	Grade	Upset type				RSC type ^d	OD	Pin ID	Pin OD length		
1	2	3	4	5	7	8	9	10	11	12	13	14
					-12,5 %	max.	± 0,8	+0,4 -0,8	± 6,4	± 6,4	± 0,4	Calculated
					See Table A.2							
Internal-external upset, IEU												
5	19.50	E	IEU	NC50	9,19	130,2	168,3	95,3	177,80	254,00	153,99	31,79
5	19.50	X	IEU	NC50	9,19	130,2	168,3	88,9	177,80	254,00	153,99	32,58
5	19.50	G	IEU	NC50	9,19	130,2	168,3	82,6	177,80	254,00	153,99	32,95
5	19.50	S	IEU	NC50	9,19	130,2	168,3	69,9	177,80	254,00	153,99	33,60
5	19.50	E	IEU	5 1/2 FH	9,19	130,2	177,8	95,3	203,20	254,00	170,66	33,22
5	19.50	X, G	IEU	5 1/2 FH	9,19	130,2	177,8	95,3	203,20	254,00	170,66	33,61
5	19.50	S	IEU	5 1/2 FH	9,19	130,2	184,2	88,9	203,20	254,00	170,66	34,89
5	25.60	E	IEU	NC50	12,70	130,2	168,3	88,9	177,80	254,00	153,99	40,73
5	25.60	X	IEU	NC50	12,70	130,2	168,3	76,2	177,80	254,00	153,99	41,80
5	25.60	G	IEU	NC50	12,70	130,2	168,3	69,9	177,80	254,00	153,99	42,11
5	25.60	E	IEU	5 1/2 FH	12,70	130,2	177,8	88,9	203,20	254,00	170,66	42,14
5	25.60	X	IEU	5 1/2 FH	12,70	130,2	177,8	88,9	203,20	254,00	170,66	42,51
5	25.60	G	IEU	5 1/2 FH	12,70	130,2	184,2	88,9	203,20	254,00	170,66	43,35
5	25.60	S	IEU	5 1/2 FH	12,70	130,2	184,2	82,6	203,20	254,00	170,66	43,75
5-1/2	21.90	E	IEU	5 1/2 FH	9,17	144,5	177,8	101,6	203,20	254,00	170,66	35,43
5-1/2	21.90	X	IEU	5 1/2 FH	9,17	144,5	177,8	95,3	203,20	254,00	170,66	36,36

Table A.1 (continued)

Designations ^a		Pipe body OD	Pipe wall thickness	Drill-pipe weld neck	Tool joint				RSC bevel dia.	Approx. mass ^c			
					Label 1	Label 2	Grade	Upset type			RSC type ^d	OD	Pin ID
1	2	3	4	5	D_{dp} mm	t mm	D_{te}^b mm	D mm	d_p mm	L_{pb} mm	L_b mm	D_f mm	w_{dp} kg/m
					See Table A.2	-12,5 %	max.	± 0,8	+0,4 -0,8	± 6,4	± 6,4	± 0,4	Calculated
					6	7	8	9	10	11	12	13	14
Internal-external upset, IEU													
5-1/2	21.90	G	IEU	5 1/2 FH	139,70	9,17	144,5	184,2	88,9	203,20	254,00	170,66	37,61
5-1/2	21.90	S	IEU	5 1/2 FH	139,70	9,17	144,5	190,5	76,2	203,20	254,00	180,18	39,27
5-1/2	24.70	E	IEU	5 1/2 FH	139,70	10,54	144,5	177,8	101,6	203,20	254,00	170,66	39,19
5-1/2	24.70	X, G	IEU	5 1/2 FH	139,70	10,54	144,5	184,2	88,9	203,20	254,00	170,66	41,32
5-1/2	24.70	S	IEU	5 1/2 FH	139,70	10,54	144,5	190,5	76,2	203,20	254,00	180,18	42,97
6-5/8	25.20	E	IEU	6 5/8 FH	168,28	8,38	176,2	203,2	127,0	203,20	279,40	195,66	41,03
6-5/8	25.20	X	IEU	6 5/8 FH	168,28	8,38	176,2	203,2	127,0	203,20	279,40	195,66	41,03
6-5/8	25.20	G	IEU	6 5/8 FH	168,28	8,38	176,2	209,6	120,7	203,20	279,40	195,66	42,60
6-5/8	25.20	S	IEU	6 5/8 FH	168,28	8,38	176,2	215,9	108,0	203,20	279,40	195,66	44,73
6-5/8	27.70	E	IEU	6 5/8 FH	168,28	9,19	176,2	203,2	127,0	203,20	279,40	195,66	43,79
6-5/8	27.70	X, G	IEU	6 5/8 FH	168,28	9,19	176,2	209,6	120,7	203,20	279,40	195,66	45,35
6-5/8	27.70	S	IEU	6 5/8 FH	168,28	9,19	176,2	215,9	108,0	203,20	279,40	195,66	47,48
NOTE See Figure B.1.													
^a Designations are shown for the purpose of identification in ordering.													
^b D_{te} is held to a maximum to ensure fit with elevator.													
^c These values have been based on a drill-pipe-body length of 8,96 m and are provided for information only. For other lengths, see API RP 7G for the method of calculation.													
^d The RSC type indicates the size and style of the applicable rotary shouldered connection.													

Table A.2 — Drill-pipe-body outside-diameter tolerances

Label 1	Tolerance
1	2
Pipe body	
≤ 4	± 0,79 mm
> 4	+1,0 % D_{dp} -0,5 % D_{dp}
Drill-pipe-body behind the m_{eu}	
≥ 2 ^{-3/8} to ≤ 3 ^{-1/2}	+2,38 mm -0,79 mm
>3 ^{-1/2} to ≤ 5	+2,78 mm -0,75 % D_{dp}
> 5 to ≤ 6 ^{-5/8}	+3,18 mm -0,75 % D_{dp}

Table A.3 — Drill-pipe length, L

Dimensions in metres

1	Range 1	Range 2	Range 3
	2	3	4
Length, L , inclusive	6,10 to 7,01	8,84 to 9,75	12,19 to 13,72
Limitation for 95 % or order quantity ^a :			
Maximum variation	0,61	—	—
Minimum length	6,40	—	—
Limitation for 90 % of order quantity ^a :			
Maximum variation	—	0,61	0,91
Minimum length	—	9,14	12,19
^a Order quantity is the number of drill-pipe specified in the purchase agreement with the same item designations.			
NOTE See Figure B.1.			

Table A.4 — Chemical composition requirements

1	Phosphorus maximum %	Sulfur maximum %
	2	3
Pipe body: grade E	0,030	0,020
Pipe body: grades X, G and S	0,020	0,015
Tool joint	0,020	0,015

Table A.5 — Tensile requirements

1	Yield strength		Tensile strength	Elongation
	MPa		MPa	%
	min.	max.	min.	min.
	2	3	4	5
Drill-pipe-body				
Grade E	517	724	689	a
Grade X	655	862	724	a
Grade G	724	931	793	a
Grade S	931	1 138	1 000	a
Tool joint	827	1 138	965	13
a See 7.3.2.				

Table A.6 — Total gauge extension at the yield strength for drill-pipe body

Drill-pipe-body grade	Total extension of gauge length
	%
1	2
E, X	0,5
G	0,6
S	0,7

Table A.7 — Minimum pipe-body elongation values

Tensile test specimen				Minimum elongation ^a in 50,8 mm %			
Area <i>A</i> mm ²	Specified wall thickness mm			Grade			
	19 mm wide strip	25 mm wide strip	38 mm wide strip	E	X	G	S
1	2	3	4	5	6	7	8
490	—	—	≥ 12,77	19	18	16	13
480	—	—	12,51 to 12,76	19	18	16	13
470	—	—	12,24 to 12,50	19	18	16	13
460	—	—	11,98 to 12,23	18	18	16	13
450	—	—	11,72 to 11,97	18	18	16	13
440	—	—	11,45 to 11,71	18	18	16	13
430	—	—	11,19 to 11,44	18	17	16	13
420	—	—	10,93 to 11,18	18	17	16	13
410	—	—	10,66 to 10,92	18	17	16	13
400	—	—	10,40 to 10,65	18	17	16	13
390	—	—	10,14 to 10,39	18	17	16	13
380	—	—	9,87 to 10,13	18	17	16	13
370	—	—	9,61 to 9,86	18	17	16	13
360	—	—	9,35 to 9,60	18	17	16	13
350	—	—	9,08 to 9,34	18	17	15	13
340	—	—	8,82 to 9,07	17	17	15	12
330	—	13,01 to 13,39	8,56 to 8,81	17	17	15	12
320	—	12,60 to 13,00	8,29 to 8,55	17	16	15	12
310	—	12,21 to 12,59	8,03 to 8,28	17	16	15	12
300	—	11,80 to 12,20	7,77 to 8,02	17	16	15	12
290	—	11,41 to 11,79	7,51 to 7,76	17	16	15	12
280	—	11,00 to 11,40	7,24 to 7,50	17	16	15	12
270	—	10,61 to 10,99	6,98 to 7,23	17	16	15	12
260	—	10,20 to 10,60	6,72 to 6,97	16	16	15	12
250	—	9,81 to 10,19	6,45 to 6,71	16	16	14	12
240	—	9,40 to 9,80	—	16	16	14	12
230	—	9,01 to 9,39	—	16	15	14	12
220	11,32 to 11,84	8,60 to 9,00	—	16	15	14	11
210	10,79 to 11,31	8,21 to 8,59	—	16	15	14	11
200	10,27 to 10,78	—	—	16	15	14	11
190	9,74 to 10,26	—	—	15	15	14	11
180	9,22 to 9,73	—	—	15	15	14	11
170	8,69 to 9,21	—	—	15	14	13	11

Table A.7 (continued)

Tensile test specimen				Minimum elongation ^a in 50,8 mm %			
Area <i>A</i> mm ²	Specified wall thickness mm			Grade			
	19 mm wide strip	25 mm wide strip	38 mm wide strip	E	X	G	S
1	2	3	4	5	6	7	8
160	8,16 to 8,68	—	—	15	14	13	11
150	7,64 to 8,15	—	—	15	14	13	11
140	7,11 to 7,63	—	—	15	14	13	10
130	6,58 to 7,10	—	—	14	14	13	10
120	6,06 to 6,57	—	—	14	14	12	10

^a The minimum elongation for either round-bar tensile specimens (the 8,8 mm diameter with 35,6 mm gauge length and the 12,5 mm diameter with 50,8 mm gauge length) shall be that shown in this table for a cross-sectional area, *A*, of 130 mm².

Table A.8 — Charpy V-notch longitudinal absorbed-energy requirements

Product element	Minimum average absorbed energy J			Minimum specimen absorbed energy ^a J		
	Specimen size mm × mm			Specimen size mm × mm		
	10 × 10	10 × 7,5	10 × 5	10 × 10	10 × 7,5	10 × 5
1	2	3	4	5	6	7
PSL-1 — Test temperature: 21 °C ± 3 °C						
Drill-pipe body: grades X, G, S	54	43	30	47	38	26
Tool joint (box and pin)	54	43	30	47	38	26
Weld zone	16	14	—	14	11	—
SR19 — Test temperature: 21 °C ± 3 °C						
Drill-pipe body: grade E	54	43	30	47	38	26
SR20 — Test temperature: -10 °C ± 3 °C See E.5.2						
Drill-pipe body: all grades	41	33	27	30	24	20
Tool joint (box and pin)	41	33	27	30	24	20
Weld zone	16	14	—	14	11	—
SR24 — Test temperature: 21 °C ± 3 °C						
Weld zone	27	22	—	23	19	—
PSL-3 — Test temperature -20 °C ± 3 °C						
Drill-pipe body: all grades	100	80	56	80	64	43
Tool joint (box and pin)	54	43	30	47	38	26
Weld zone	42	34	—	32	26	—

^a The percent shear area shall be measured and reported for information only.

Table A.9 — Retention of records

Requirements	Reference (subclause)		
	Drill-pipe	Drill-pipe-body	Tool joints
1	2	3	4
Chemical properties:			
Heat analyses	—	7.7.1	—
Product analyses	—	7.7.2	8.7.2
Mechanical properties:			
Tensile tests	6.8	7.8	8.8
Hardness tests	6.9	—	8.9
Charpy tests	6.10	7.9	8.10
Transverse side-bend tests	6.11	—	—
NDE system capability verification	6.14.5	7.19.8	—
Calibration	Various	Various	Various

Table A.10 — Test frequency

1	Chemical analysis	Tensile test	Charpy impact test	Outside surface hardness test	Through-wall hardness test	Side-bend test
1	2	3	4	5	6	7
Drill-pipe-body — Grade E — PSL-1						
< Label 1: 6 ^{-5/8}	2 product per heat	1 per 400 or per lot ^a	—	—	—	—
≥ Label 1: 6 ^{-5/88}	2 product per heat	1 per 200 or per lot ^a	—	—	—	—
Drill-pipe-body — Grade E — SR19						
< Label 1: 6 ^{-5/8}	—	—	1 per 400 or per lot ^a	—	—	—
≥ Label 1: 6 ^{-5/8}	—	—	1 per 200 or per lot ^a	—	—	—
Drill-pipe-body — Grades X, G and S — PSL-1						
< Label 1: 6 ^{-5/8}	2 product per heat	1 per 200 or per lot ^a	1 per 200 or per lot ^a	—	—	—
≥ Label 1: 6 ^{-5/8}	2 product per heat	1 per 100 or per lot ^a	1 per 100 or per lot ^a	—	—	—
Tool joints — PSL-1						
Pin	1 per heat (solid form)	1 per 200 or per lot ^a	1 per 200 or per lot ^a	—	1 per 200 or per lot ^b	—
Box	1 per heat (solid form)	—	1 per 200 or per lot ^a	—	1 per 200 or per lot ^a	—

Table A.10 (continued)

1	Chemical analysis	Tensile test	Charpy impact test	Outside surface hardness test	Through-wall hardness test	Side bend test
1	2	3	4	5	6	7
Tool joints — PSL-3						
Pin	1 per heat (solid form)	1 per 200 or per lot ^a	—	Each pin	1 per 200 or per lot ^d	—
Box	1 per heat (solid form)	1 per 200 or per lot ^{a,c}	—	Each box	1 per 200 or per lot ^d	—
Weld line — PSL-1						
—	—	1 per 400 welds or per weld lot ^a	1 per 400 welds or per weld lot ^a	All welds at 3 locations 120° apart	1 per 400 welds or per weld lot ^a	1 per 400 welds or per weld lot ^a
Weld line — PSL-1, SR23						
—	—	1 per 200 welds or per weld lot ^a	1 per 200 welds or per weld lot ^a	All welds at 3 locations 120° apart	1 per 200 welds or per weld lot ^a	1 per 200 welds or per weld lot ^a
Weld line — PSL-2						
—	—	1 per 200 welds or per weld lot ^a	1 per 200 welds or per weld lot ^a	—	1 per 200 welds or per weld lot ^a	1 per 200 welds or per weld lot ^a
Weld line — PSL-3						
—	—	1 per 100 welds or per weld lot ^a	1 per 100 welds or per weld lot ^a	—	1 per 100 welds or per weld lot ^a	1 per 100 welds or per weld lot ^a
^a Whichever is the smaller quantity. ^b Only required if a tensile specimen cannot be obtained from the pin tool joint. ^c As close as practicable to the tool-joint shoulder unless otherwise specified in the purchase agreement. ^d This through-wall test is in addition to the test that is required for PSL-1.						

Table A.11 — Calculated wall thickness required to machine longitudinal Charpy impact specimens

Specified outside diameter	Calculated wall thickness required to machine longitudinal Charpy impact specimens		
	mm		
	Full-size	$\frac{3}{4}$ -size	$\frac{1}{2}$ -size
1	2	3	4
60,33	11,42	8,92	6,42
63,50	11,40	8,90	6,40
66,68	11,38	8,88	6,38
69,85	11,36	8,86	6,36
73,03	11,34	8,84	6,34
76,20	11,33	8,83	6,33
79,38	11,32	8,82	6,32
82,55	11,30	8,80	6,30
85,73	11,29	8,79	6,29
88,90	11,28	8,78	6,28
92,08	11,27	8,77	6,27
95,25	11,26	8,76	6,26
98,43	11,25	8,75	6,25
101,60	11,25	8,75	6,25
104,78	11,24	8,74	6,24
107,95	11,23	8,73	6,23
111,13	11,23	8,73	6,23
114,30	11,22	8,72	6,22
117,48	11,21	8,71	6,21
120,70	11,21	8,71	6,21
123,83	11,20	8,70	6,20
127,00	11,20	8,70	6,20
130,18	11,19	8,69	6,19
133,35	11,19	8,69	6,19

Table A.11 (continued)

Specified outside diameter	Calculated wall thickness required to machine longitudinal Charpy impact specimens		
	mm		
	Full-size	$\frac{3}{4}$ -size	$\frac{1}{2}$ -size
1	2	3	4
136,53	11,18	8,68	6,18
139,70	11,18	8,68	6,18
142,88	11,18	8,68	6,18
146,05	11,17	8,67	6,17
149,23	11,17	8,67	6,17
152,40	11,16	8,66	6,16
155,58	11,16	8,66	6,16
158,75	11,16	8,66	6,16
161,93	11,15	8,65	6,15
165,10	11,15	8,65	6,15
168,28	11,15	8,65	6,15
171,45	11,15	8,65	6,15
174,63	11,14	8,64	6,14
177,80	11,14	8,64	6,14
180,98	11,14	8,64	6,14
184,15	11,14	8,64	6,14
187,33	11,13	8,63	6,13
190,50	11,13	8,63	6,13
193,68	11,13	8,63	6,13
196,85	11,13	8,63	6,13
200,03	11,13	8,63	6,13
203,20	11,12	8,62	6,12
206,38	11,12	8,62	6,12
209,55	11,12	8,62	6,12
212,73	11,12	8,62	6,12
215,90	11,12	8,62	6,12
219,08	11,11	8,61	6,11
222,25	11,11	8,61	6,11
225,43	11,11	8,61	6,11
228,60	11,11	8,61	6,11

NOTE The above provides 0,50 mm ID and 0,50 mm OD machining allowances.

Table A.12 — Drill-pipe-mass code number

Designation		Wall thickness	Mass code number
Label 1	Label 2	mm	
1	2	3	4
2- ³ / ₈	6.65	7,11	2
2- ⁷ / ₈	10.40	9,19	2
3- ¹ / ₂	9.50	6,45	1
3- ¹ / ₂	13.30	9,35	2
3- ¹ / ₂	15.50	11,40	3
4	14.00	8,38	2
4- ¹ / ₂	13.75	6,88	1
4- ¹ / ₂	16.60	8,56	2
4- ¹ / ₂	20.00	10,92	3
5	19.50	9,19	2
5	25.60	12,70	3
5- ¹ / ₂	21.90	9,17	2
5- ¹ / ₂	24.70	10,54	3
6- ⁵ / ₈	25.20	8,38	2
6- ⁵ / ₈	27.70	9,19	3

NOTE Mass code number "2" denotes a standard weight for the drill-pipe size.

Table A.13 — Grade E drill-pipe-body dimensions, tolerances and masses

Designation ^a		Pipe-body dimensions					Upset dimensions ^{b,c}							ϵ_w kg
		D_{dp} mm See Table A.2	t mm -12,5 %	d_{dp} mm	w_{pe} kg/m	D_{ou} mm ^{+3,18 d} _{-0,79}	d_{ou} mm $\pm 1,59e$	L_{iu} mm ^{+38,10 f} _{-12,70}	m_{iu} mm min. g	L_{eu} mm min.	m_{eu} mm min.	$L_{eu} + m_{eu}$ mm max.	ϵ_w kg	
1	2	3	4	5	6	7	8	9	10	11	12	13	14	15
Internal upset (IU)														
4	14.00	101,60	8,38	84,84	19,27	107,95	69,85	44,45	50,80	—	—	—	—	2,09
4-1/2	13.75	114,30	6,88	100,54	18,23	120,65	85,72	44,45	—	—	—	—	—	2,36
External upset (EU)														
2-3/8	6.65	60,32	7,11	46,10	9,33	67,46	46,10	—	—	38,10	38,10	—	101,60	0,82
2-7/8	10.40	73,02	9,19	54,64	14,47	81,76	54,64	—	—	38,10	38,10	—	101,60	1,09
3-1/2	9.50	88,90	6,45	76,00	13,12	100,03	76,00	—	—	38,10	38,10	—	101,60	1,18
3-1/2	13.30	88,90	9,35	70,20	18,34	100,03	66,09	57,15	50,80	38,10	38,10	—	101,60	1,82
3-1/2	15.50	88,90	11,40	66,10	21,79	100,03	66,09	—	—	38,10	38,10	—	101,60	1,27
4	14.00	101,60	8,38	84,84	19,27	115,90	84,84	—	—	38,10	38,10	—	101,60	2,27
4-1/2	13.75	114,30	6,88	100,54	18,23	126,60	100,53	—	—	38,10	38,10	—	101,60	2,54
4-1/2	16.60	114,30	8,56	97,18	22,32	128,60	97,18	—	—	38,10	38,10	—	101,60	2,54
4-1/2	20.00	114,30	10,92	92,46	27,84	128,60	92,46	—	—	38,10	38,10	—	101,60	2,54

Table A.13 (continued)

Designation ^a		Pipe-body dimensions					Upset dimensions ^{b,c}								ϵ_w kg
		D_{dp} mm See Table A.2	t mm -12,5 %	d_{dp} mm	w_{pe} kg/m	D_{ou} mm $+3,18^d$ $-0,79$	d_{ou} mm $\pm 1,59^e$	L_{iu} mm $+38,10^f$ $-12,70$	m_{iu} mm min. ^g	L_{eu} mm min.	m_{eu} mm min.	$L_{eu} + m_{eu}$ mm max.	ϵ_w kg		
Label 1	Label 2	3	4	5	6	7	8	9	10	11	12	13	14	15	
Internal-external upset (IEU)															
4-1/2	16,60	114,30	8,56	97,17	22,32	120,65	80,16	63,50	50,80	38,10	25,40	38,10	—	3,68	
4-1/2	20,00	114,30	10,92	92,46	27,84	121,44	76,20	57,15	50,80	38,10	25,40	38,10	—	3,90	
5	19,50	127,00	9,19	108,62	26,70	131,78	93,68	57,15	50,80	38,10	25,40	38,10	—	3,90	
5	25,60	127,00	12,70	101,60	35,80	131,78	87,33	57,15	50,80	38,10	25,40	38,10	—	3,51	
5-1/2	21,90	139,70	9,17	121,36	29,52	146,05	101,60	57,15	50,80	38,10	25,40	38,10	—	4,81	
5-1/2	24,70	139,70	10,54	118,62	33,57	146,05	101,60	57,15	50,80	38,10	25,40	38,10	—	4,09	
6-5/8	25,20	168,28	8,38	151,52	33,05	177,80	135,00	114,30	50,80	76,20	—	—	139,70	—	
6-5/8	27,70	168,28	9,19	149,90	36,06	177,80	135,00	114,30	50,80	76,20	—	—	139,70	—	

NOTE See Figure B.6.

^a Designations are shown for the purpose of identification in ordering.

^b The specified upset dimensions do not necessarily agree with the bore and OD dimensions of finished weld-on product. Upset dimensions were chosen to accommodate the various bores of tool joints and to maintain a satisfactory cross-section in the weld zone after final machining of the product.

^c When specified in the purchase agreement, the length of upset for grade E drill-pipe may be the same as for grades X, G and S.

^d For internal-upset drill-pipe-body, the tolerance on the outside diameter of the upset, D_{ou} , shall be $+3,18$ mm. A slight external upset within these tolerances is permissible.

^e Maximum taper on inside diameter of internal upset and internal-external upset is 21 mm/m on diameter.

^f The L_{iu} tolerance for label 1: $6-5/8$ drill-pipe is $+50,80$ mm.

^g Label 1: 3-1/2 and label 2: 13.30 external-upset drill-pipe has a slight internal upset not illustrated in Figure B.6.

Table A.14 — Grades X, G and S drill-pipe-body dimensions, tolerances and masses

Designation ^a		Pipe-body dimensions				Upset dimensions ^b						
		D_{dp} mm	t mm	d_{dp} mm	w_{pe} kg/m	D_{0u} mm	d_{0u} mm	L_{iu} mm	m_{iu} mm	L_{eu} mm	$L_{eu} + m_{eu}$ mm	e_w kg
Label 1	Label 2	See Table A.2	-12,5 %			$^{+3,18}_{-0,79}$ c	$\pm 1,59$ d	$^{+38,10}_{-12,70}$ e	min.	min.	max.	
1	2	3	4	5	6	7	8	9	10	11	12	13
Internal-upset (IU)												
3-1/2	13.30	88,90	9,35	70,20	18,34	88,90	49,21	88,90	—	—	—	3,36
4	14.00	101,60	8,38	84,84	19,27	107,95	68,68	88,90	—	—	—	4,00
External-upset (EU)												
2-3/8	6.65	60,32	7,11	46,10	9,33	67,46	39,67	107,95	—	76,20	139,70	2,09
2-7/8	10.40	73,02	9,19	54,64	14,47	82,55	49,23	107,95	—	76,20	139,70	2,80
3-1/2	13.30	88,90	9,35	70,20	18,34	101,60	63,50	107,95	—	76,20	139,70	4,63
3-1/2	15.50	88,90	11,40	66,10	21,79	101,60	63,50	107,95	—	76,20	139,70	3,72
4	14.00	101,60	8,38	84,84	19,27	117,48	77,77	107,95	—	76,20	139,70	6,54
4-1/2	16.60	114,30	8,56	97,18	22,32	131,78	90,47	107,95	—	76,20	139,70	7,81
4-1/2	20.00	114,30	10,92	92,46	27,84	131,78	87,33	107,95	—	76,20	139,70	7,26
Internal-external upset (IEU)												
4-1/2	16.60	114,30	8,56	97,18	22,32	120,65	73,02	63,50	76,20	38,10	76,20	3,95
4-1/2	20.00	114,30	10,92	92,46	27,84	121,44	71,42	107,95	76,20	76,20	139,70	7,99
5	19.50	127,00	9,19	108,62	26,70	131,78	90,47	107,95	76,20	76,20	139,70	7,63
5	25.60	127,00	12,70	101,60	35,80	131,78	84,12	107,95	76,20	76,20	139,70	6,99
5-1/2	21.90	139,70	9,17	121,36	29,52	146,05	96,82	107,95	76,20	76,20	139,70	9,53
5-1/2	24.70	139,70	10,54	118,62	33,57	146,05	96,82	107,95	76,20	76,20	139,70	8,35
6-5/8	25.20	168,28	8,38	151,52	33,04	177,80	135,00	114,30	76,20	76,20	139,70	—
6-5/8	27.70	168,28	9,19	149,90	36,05	177,80	135,00	114,30	76,20	76,20	139,70	—
NOTE See Figure B.6.												
<p>a Designations are shown for the purpose of identification in ordering.</p> <p>b The specified upset dimensions do not necessarily agree with the bore and OD dimensions of finished drill-pipe. Upset dimensions were chosen to accommodate the various bores of tool joints and to maintain a satisfactory cross-section in the weld zone after final machining.</p> <p>c For internal-upset drill-pipe body, the tolerance on the outside diameter of the upset, D_{0u}, shall be $^{+3,18}_{0}$ mm. A slight external upset within these tolerances is permissible.</p> <p>d Maximum taper on inside diameter of internal upset and internal-external upset is 21 mm/m on diameter.</p> <p>e The L_{iu} tolerance for label 1: 6-5/8 is $^{+50,80}_{-12,70}$ mm.</p>												

Table A.15 — Drill-pipe-body upset — Maximum permissible depth of imperfections (measured from the surface)

Item	Surface	Depth %	Measurement notes
1	2	3	4
1	All surfaces from the planes as in items 2 and 3 below throughout the upset interval	12,5	Percentage of specified drill-pipe-body wall thickness; for non-linear imperfections; for all grades of drill-pipe-body
		12,5	Percentage of specified drill-pipe-body wall thickness; for linear imperfections; for grade E drill-pipe-body
		5	Percentage of specified drill-pipe-body wall thickness; for linear imperfections; for grades X, G and S drill-pipe-body
2	On the external upset surface, from the end of the drill-pipe-body to a plane at a distance equal to the specified minimum dimension, L_{eu} , (see Figure B.6) from the end of the drill-pipe-body, the maximum permissible depth is as indicated by the requirement for maintaining dimension D_{ou} .		
3	On the internal upset surface from the end of the drill-pipe-body to a plane at a distance equal to the specified minimum dimension, L_{iu} , (see Figure B.6) from the end of the drill-pipe-body, the maximum permissible depth is as indicated by the requirement for maintaining dimension d_{ou} .		
4	The minimum permissible drill-pipe-body wall thickness in the upset taper interval, and the maximum combined effect of coincident internal and external imperfections in all areas, shall not result in less than the minimum permissible pipe-body wall thickness.		
5	Elephant hide shall be inspected as stated in 7.17.4 and in accordance with item 1 tolerances above.		

Table A.16 — Required inspection methods

Grade	Inspection method		
	Visual	Electromagnetic	Ultrasonic
1	2	3	4
E, X, G, S	R	A	A

R – Required.
A – One method or any combination of methods shall be used.

Table A.17 — Artificial reference indicators for the drill-pipe body

Grade	Notch location		Notch orientation ^a		Notch dimensions		
	OD	ID	Long.	Trans.	Depth ^b %	Max. length at full depth mm	Max width mm
1	2	3	4	5	6	7	8
E, X, G	c	c	c	c	12,5	50,8	1,0
S	c	c	c	c	5,0	50,8	1,0

^a Notches shall be square or U-shaped as in ASTM E213. At the option of the drill-pipe manufacturer, notches may be oriented at such an angle as to optimize detection of anticipated defects.

^b Depth as a percentage of specified pipe-body wall thickness. The depth tolerance shall be $\pm 15\%$ of the calculated notch depth with a minimum notch depth of $0,3\text{ mm} \pm 0,05\text{ mm}$.

^c Required when using notches.

Annex B
(normative)

Figures in SI (USC) units

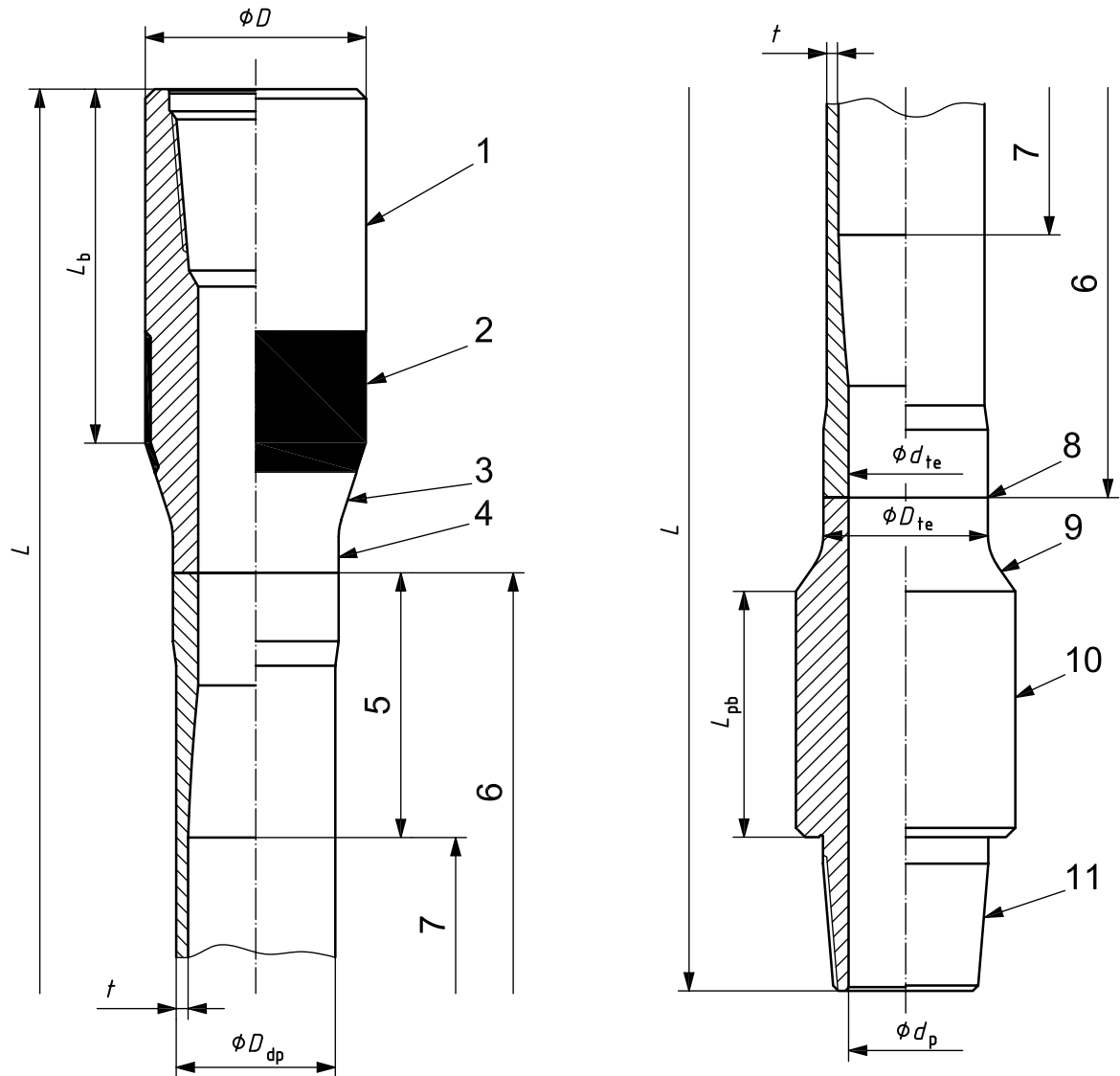

Key

- | | | | |
|---|---------------------------|----|-------------------------------|
| 1 | tool-joint box | 7 | pipe body |
| 2 | hard banding (optional) | 8 | friction weld |
| 3 | tapered elevator shoulder | 9 | pin taper |
| 4 | drill-pipe weld neck | 10 | tool-joint pin |
| 5 | drill-pipe-body upset | 11 | rotary shouldered connection. |
| 6 | drill-pipe-body | | |

NOTE See Tables A.1, A.2 or A.3 or Tables C.1, C.2 or C.3 and 6.2 for dimensional requirements.

Figure B.1 — Drill-pipe

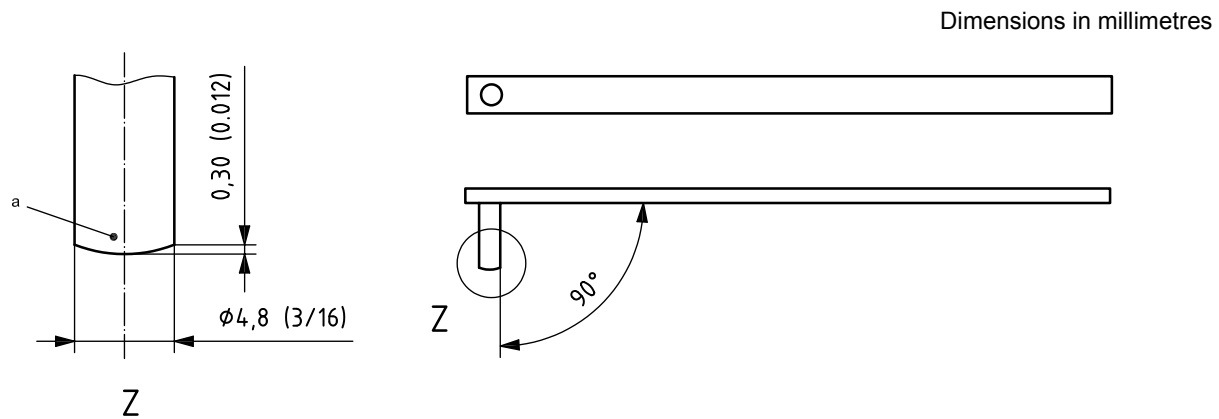

Key

- a Rounded contact point.

Figure B.2 — Example of a typical hook-type tool

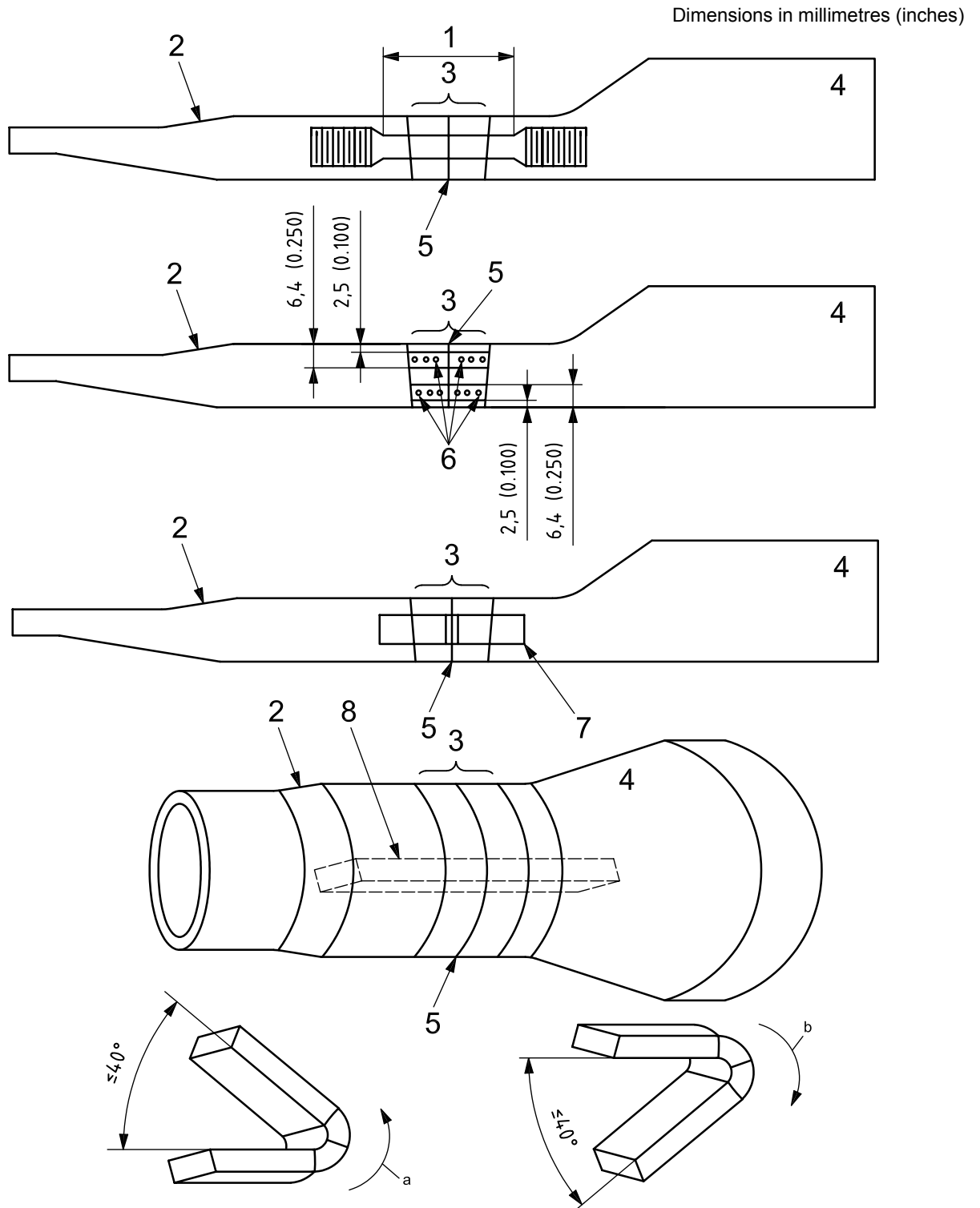

Key

- | | | | |
|---|----------------------------------|---|------------------------------|
| 1 | tensile specimen reduced section | 6 | areas for checking hardness |
| 2 | pipe-body upset | 7 | longitudinal Charpy specimen |
| 3 | weld zone | 8 | location of test specimen |
| 4 | tool joint | a | Counter-clockwise. |
| 5 | weld line | b | Clockwise. |

Figure B.3 — Location and orientation of mechanical test specimens for weld

Dimensions in millimetres (inches)

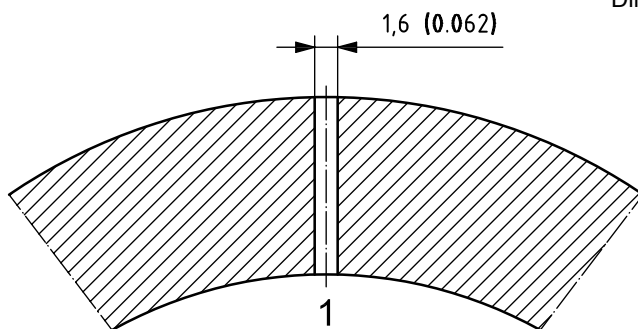

Key

1 drilled hole

Figure B.4 — Reference indicator for drill-pipe weld zone

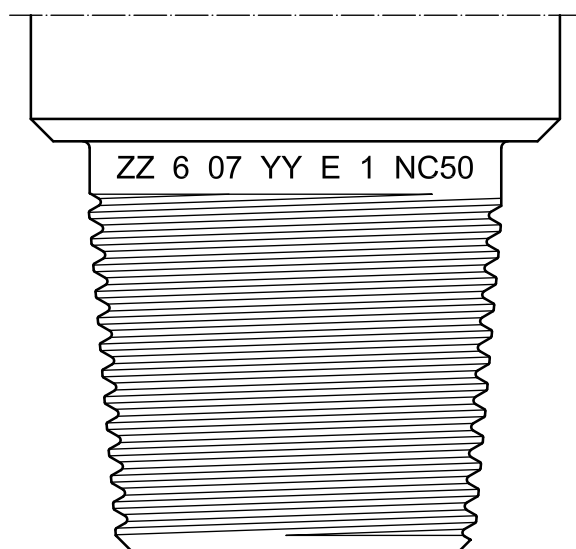
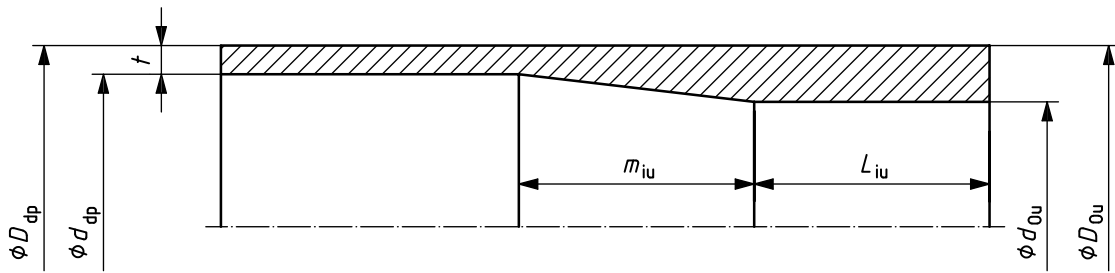
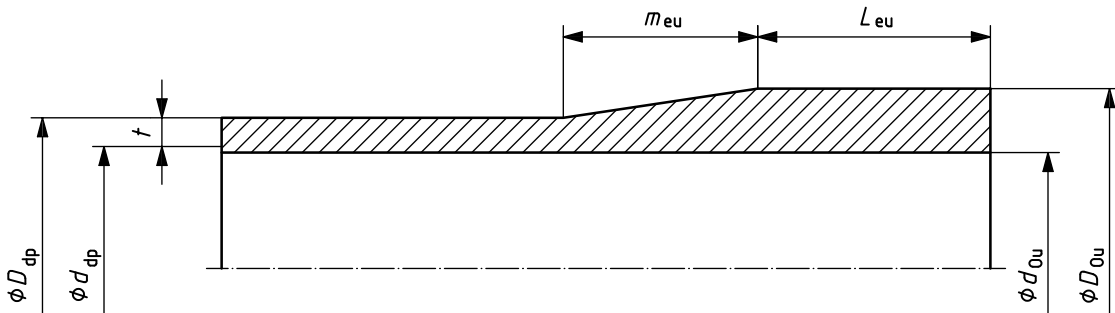

Figure B.5 — Example of marking at the base of tool-joint pin



a) Internal upset (IU)



b) External upset (EU) — Grade E (except label 1:3-1/2, label 2:13.30)

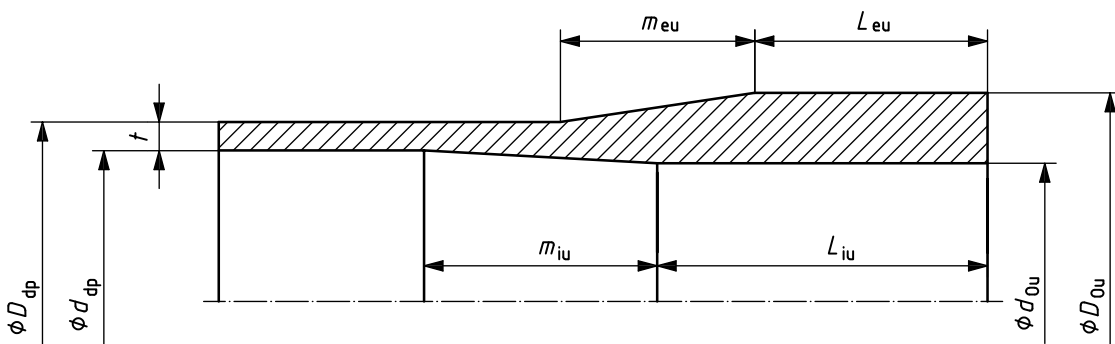

c) External upset (EU) — Grades X, G, S and E: label 1:3-1/2, label 2:13.30

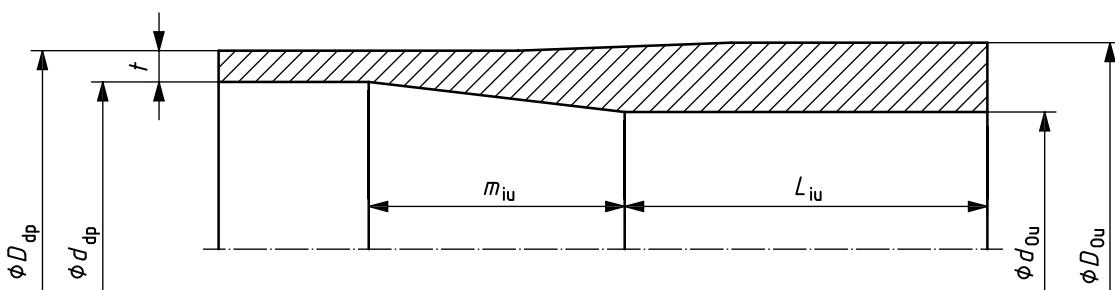

d) Internal-external upset (IEU)

NOTE See Tables A.13 or A.14 or Tables C.13 or C.14, as applicable, for drill-pipe-body upset-end dimensions.

Figure B.6 — Upset end for drill-pipe-body

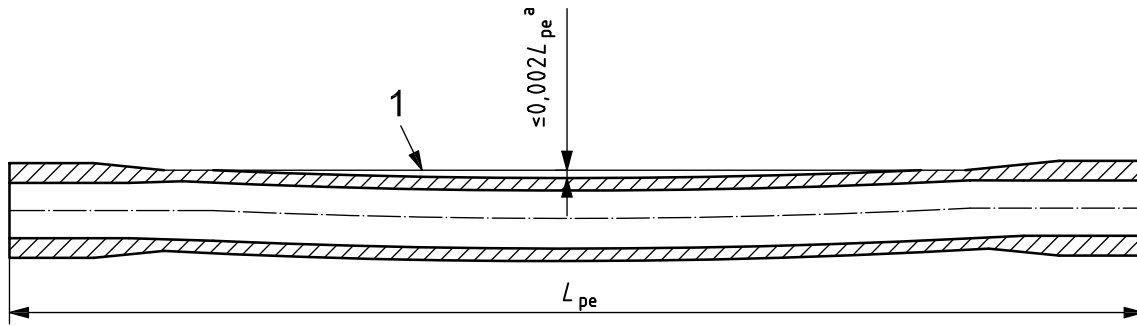

a) Measuring full-length straightness

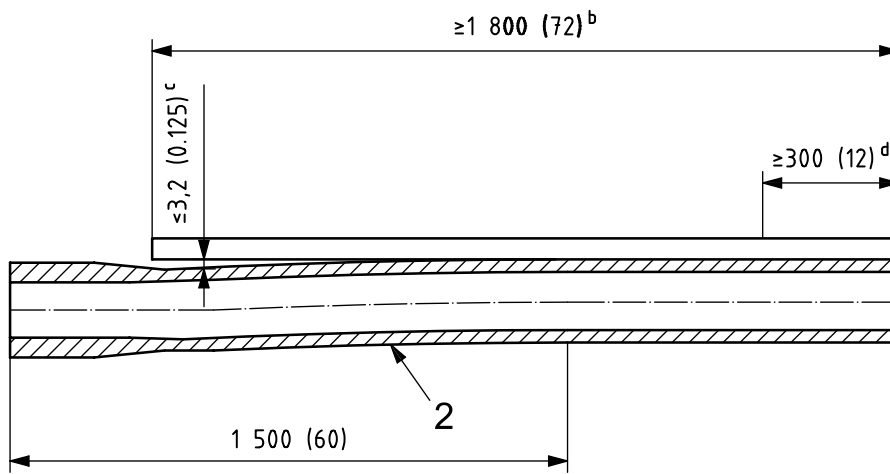

b) Measuring end straightness

Key

- 1 taut string or wire
- 2 hooked end

- a Maximum chord height deviation.
- b Minimum straight edge.
- c Maximum drop.
- d Minimum contact.

Figure B.7 — Drill-pipe-body — Measuring full-length straightness and end straightness

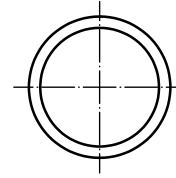
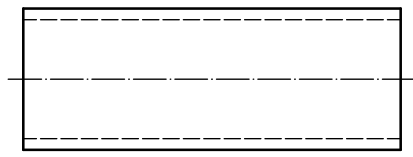

a) Full-section specimen

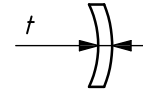
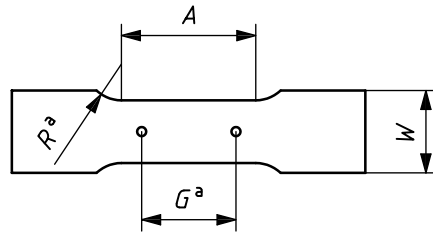

b) Strip specimen

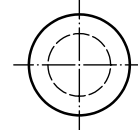
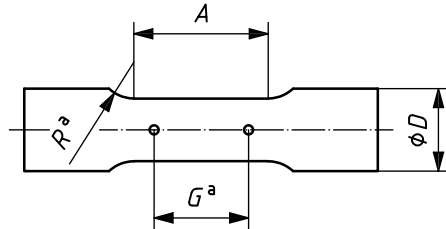

c) Round-bar specimen

^a The gauge length and fillets shall be as shown, but the ends may be of any form to fit the holders of the testing machine.

Figure B.8 (continued)

Strip-specimen dimensions

Dimensions in millimetres (inches)

Dimension and symbol		Nominal width		
		38,1 (1.500)	25,4 (1.000)	19,0 (0.750)
<i>G</i>	Gauge length	50,8 ± 0,127 (2.000 ± 0.005)	50,8 ± 0,127 (2.000 ± 0.005)	50,8 ± 0,127 (2.000 ± 0.005)
<i>W</i>	Width	38,1 ± 3,175 (1.500 ± 0.125)	25,4 ± 1,575 (1.000 ± 0.062)	19,0 ± 0,787 (0.750 ± 0.031)
<i>R</i>	Radius of fillet, min.	25,4 (1.000)	25,4 (1.000)	25,4 (1.000)
<i>A</i>	Length of reduced section, min.	57,1 (2.250)	57,1 (2.250)	57,1 (2.250)

Round-bar-specimen dimensions

Dimensions in millimetres (inches)

Dimension and symbol		Nominal diameter	
		12,5 (0.500)	8,75 (0.350)
<i>G</i>	Gauge length	50,0 ± 0,10 (2.000 ± 0.005)	35,0 ± 0,10 (1.400 ± 0.005)
<i>D</i>	Diameter	12,5 ± 0,25 (0.500 ± 0.010)	8,75 ± 0,18 (0.350 ± 0.007)
<i>R</i>	Radius of fillet, min.	10,0 (0.375)	6,0 (0.250)
<i>A</i>	Length of reduced section, min.	60,0 (2.250)	45,0 (1.750)

Figure B.8 — Tensile-test specimens for drill-pipe-body

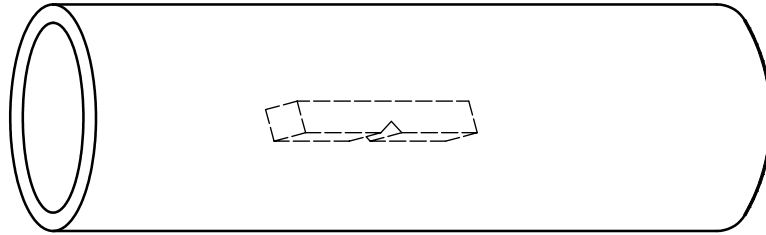

a) Drill-pipe body — Charpy specimen

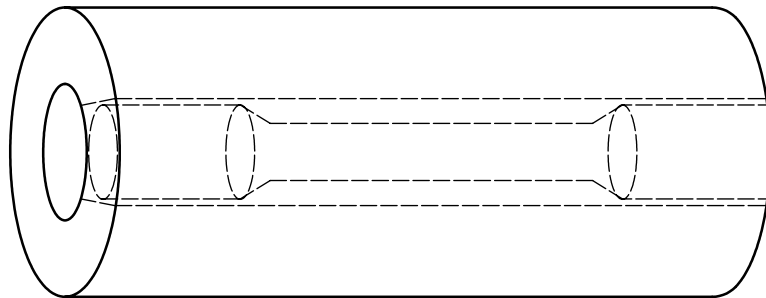

b) Drill-pipe-body tensile — Round-bar specimen

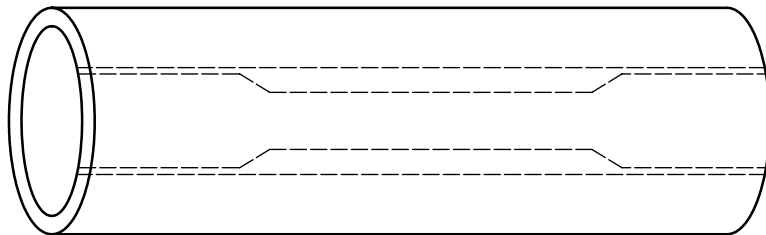

c) Drill-pipe-body tensile — Strip specimen

The edges of the blank for the specimen shall be cut parallel to each other.

Figure B.9 — Location and orientation of mechanical test specimens for drill-pipe-body

Dimensions in millimetres (inches)

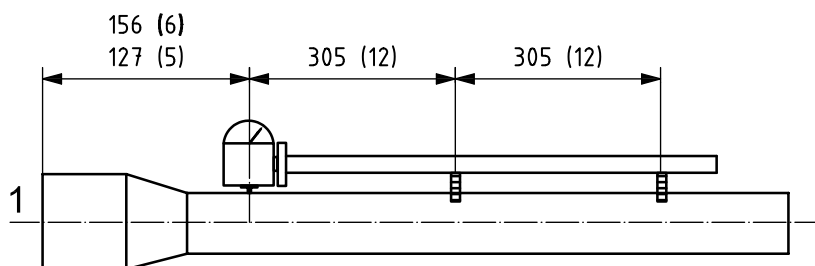

a) Upset misalignment

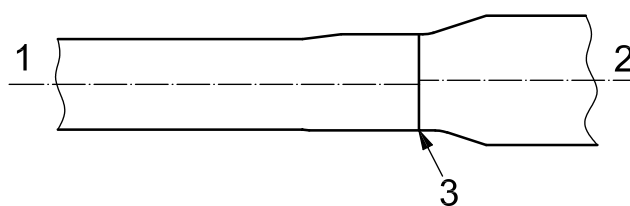

b) Parallel misalignment

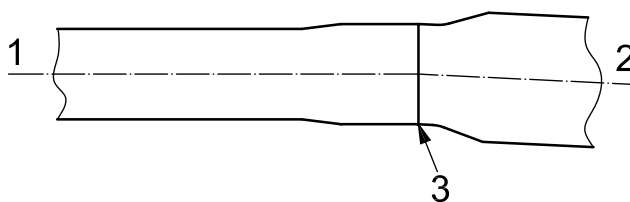

c) Angular misalignment

Key

- 1 axis of drill-pipe body
- 2 axis of tool joint
- 3 weld line

Figure B.10 — Upset and tool-joint alignment

Dimensions in millimetres (inches)

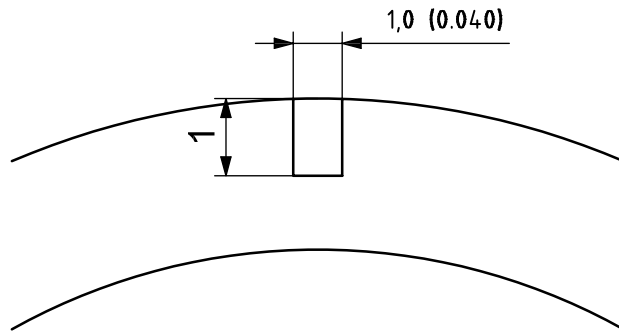

Key

- 1 notch depth

Figure B.11 — Reference indicator (notch) for a pipe body

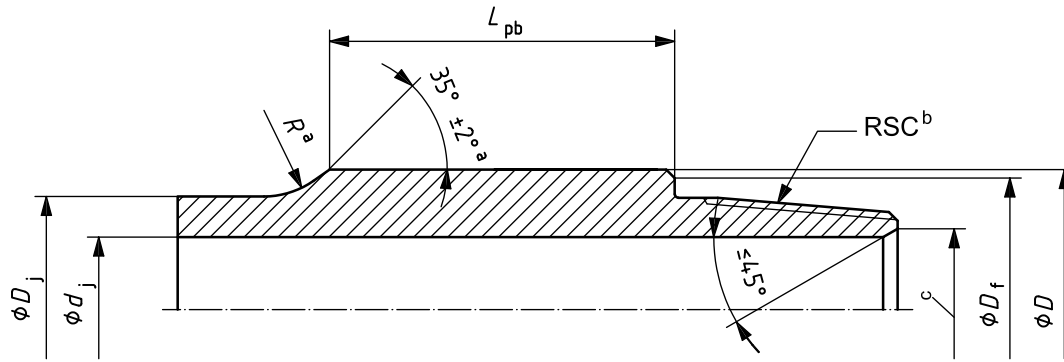

a) Pin tool joint

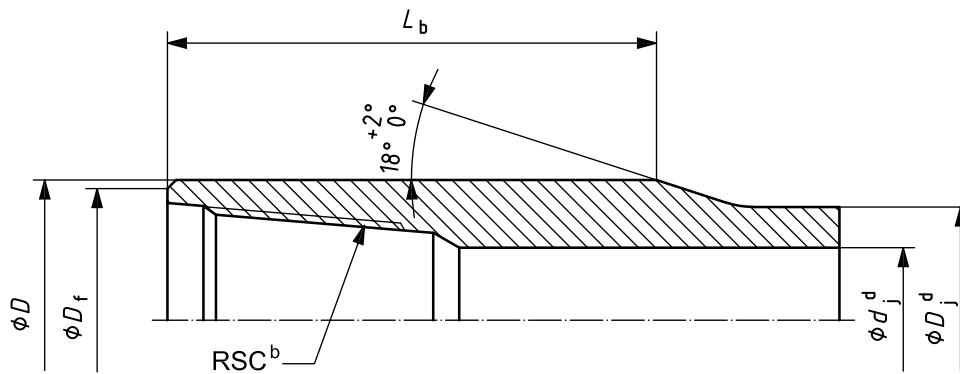

b) Box tool joint

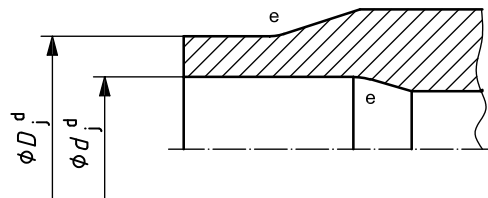

c) Step bore option for weld neck

NOTE: See Table A.1 or Table C.1 for other tool-joint dimensions.

- a Size of radius, R , at the end of the 35° taper on the pin shall be at the drill-pipe manufacturer's option. When specified on the purchase agreement, 35° shall be replaced with 18° and $R = 38$ mm (1.5 in).
- b See ISO 10424-2.
- c This diameter is at the drill-pipe manufacturer's option and shall be equal to or greater than the d_{te} for the corresponding box tool joint (see 6.2.3).
- d D_j is the outside diameter of the tool-joint weld neck, which becomes D_{te} after welding and final machining;
 d_j is the inside diameter of the tool-joint weld neck, which becomes d_{te} after welding and final machining.
 The d_{te} may be different on box and pin.
 The value of d_j is determined by the drill-pipe manufacturer based on design criteria.
 The pin and/or box may contain a step bore to achieve the design requirements.
- e The start of the internal transition shall not be coincident with the start of the external transition area.

Figure B.12 — Tool-joint pin and box

Dimensions in millimetres (inches)

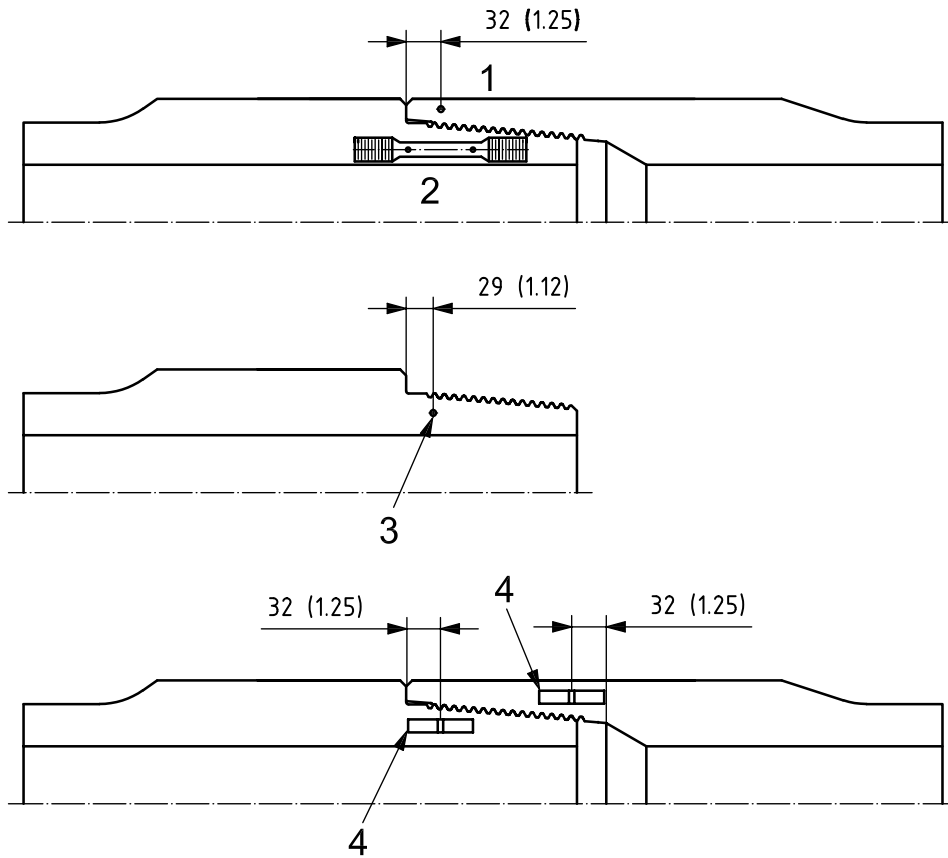

Key

- 1 box hardness test location
- 2 pin tensile test specimen
- 3 pin hardness test location when required
- 4 longitudinal Charpy specimen

Figure B.13 — Location and orientation of mechanical test specimens for tool joints

Dimensions in millimetres (inches)

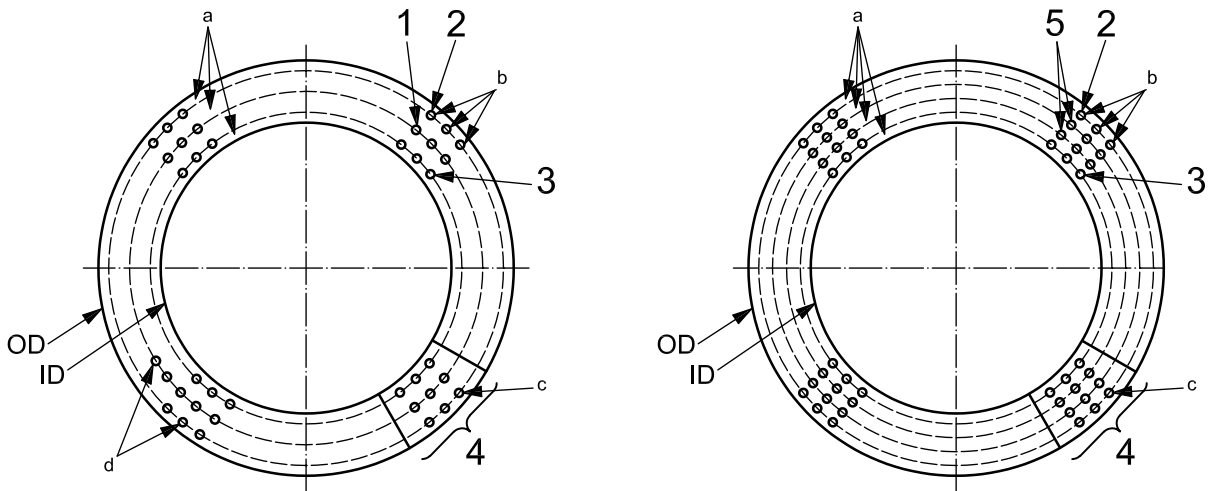

a) Thickness < 50 (< 2)

b) Thickness > 50 (> 2)

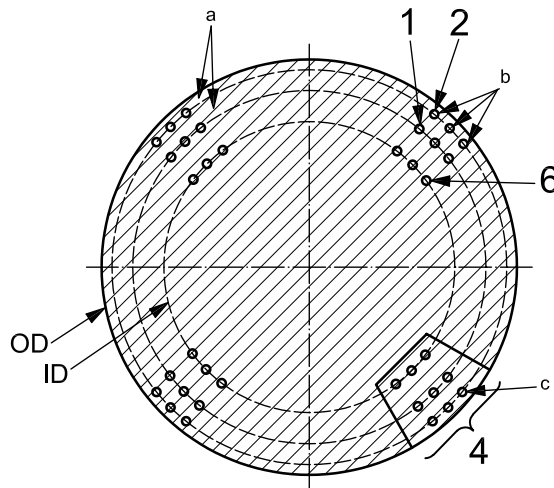

c) Solid barstock

Key

- 1 indentation at mid-wall location
- 2 indentation at OD location
- 3 indentation at ID location
- 4 hardness indentation test block
- 5 indentation at location equally spaced between OD and ID indentations
- 6 indentation on the intended (finished) ID location

- a The OD and ID indentations shall be approximately 2,5 indentation diameters from the relevant surface and 3 indentation diameters from any other indentation. Three indentations at a location are required when using the Rockwell method, but only one indentation is required at a location when using the Brinell method.
- b The mean hardness number is the average of three Rockwell hardness numbers in the same location.
- c Rockwell hardness indentation data are called Rockwell hardness numbers.
- d Alternate spacing of rows permitted for thin-wall tool joints.

Figure B.14 — Hardness-test locations

Annex C
(normative)

Tables in USC units

Table C.1 — Drill-pipe list, main dimensions and mass

Designations ^a				Pipe-body OD	Pipe wall thickness	Drill-pipe weld neck	Tool joint				RSC bevel dia.	Approx. mass ^c
Label 1	Label 2	Grade	Upset type				RSC type ^d	OD	Pin ID	Pin OD length		
1	2	3	4	5	D_{dp} in See Table C.2	t in -12.5 %	D_{te}^b in max.	d_p in $+0.016$ -0.031	L_{pb} in ± 0.250	L_b in ± 0.250	D_f in ± 0.016	w_{dp} lb/ft Calculated
					6	7	8	10	11	12	13	14
Internal upset, IU												
4	14.00	E	IU	NC40	4.000	0.330	4.188	2.812	7.000	10.000	5.016	15.06
4	14.00	X	IU	NC40	4.000	0.330	4.188	2.688	7.000	10.000	5.016	15.29
4	14.00	G	IU	NC40	4.000	0.330	4.188	2.438	7.000	10.000	5.016	15.87
4	14.00	S	IU	NC40	4.000	0.330	4.188	2.000	7.000	10.000	5.016	16.14
4-1/2	13.75	E	IU	NC46	4.500	0.271	4.688	3.375	7.000	10.000	5.719	15.12
2-3/8	6.65	E	EU	NC26	2.375	0.280	2.563	1.750	7.000	8.000	3.266	7.02
2-3/8	6.65	X, G	EU	NC26	2.375	0.280	2.563	1.750	7.000	8.000	3.266	7.11
2-7/8	10.40	E	EU	NC31	2.875	0.362	3.188	2.125	7.000	9.000	3.953	10.92
2-7/8	10.40	X, G	EU	NC31	2.875	0.362	3.188	2.000	7.000	9.000	3.953	11.09
2-7/8	10.40	S	EU	NC31	2.875	0.362	3.188	1.625	7.000	9.000	3.953	11.55
3-1/2	9.50	E	EU	NC38	3.500	0.254	3.875	2.688	8.000	10.500	4.578	10.60
3-1/2	13.30	E	EU	NC38	3.500	0.368	3.875	2.688	8.000	10.500	4.578	13.96
3-1/2	13.30	X	EU	NC38	3.500	0.368	3.875	2.562	8.000	10.500	4.578	14.62
3-1/2	13.30	G	EU	NC38	3.500	0.368	3.875	2.438	8.000	10.500	4.578	14.72
3-1/2	13.30	S	EU	NC38	3.500	0.368	3.875	2.125	8.000	10.500	4.578	14.93
3-1/2	15.50	E	EU	NC38	3.500	0.449	3.875	2.563	8.000	10.500	4.578	16.58
3-1/2	15.50	X	EU	NC38	3.500	0.449	3.875	2.438	8.000	10.500	4.578	16.84
3-1/2	15.50	G	EU	NC38	3.500	0.449	3.875	2.125	8.000	10.500	4.578	17.06
3-1/2	15.50	S	EU	NC40	3.500	0.449	3.875	2.250	7.000	10.000	5.016	17.60

Table C.1 (continued)

Designations ^a		Pipe body OD	Pipe wall thickness	Drill-pipe weld neck	Tool joint				RSC bevel dia.	Approx. mass ^c			
					OD	Pin ID	Pin OD length	Box OD length					
Label 1	Label 2	Grade	Upset type	RSC type ^d	D_{dp} in	t in	D_{te}^b in	D in	d_p in	L_{pb} in	L_b in	D_f in	W_{dp} lb/ft
1	2	3	4	5	6	7	8	9	10	11	12	13	Calculated
					See Table C.2	-12.5 %	max.	± 0.031	$+0.016$ -0.031	± 0.250	± 0.250	± 0.016	
External upset, EU													
4	14.00	E	EU	NC46	4.000	0.330	4.500	6.000	3.250	7.000	10.000	5.719	15.91
4	14.00	X, G	EU	NC46	4.000	0.330	4.500	6.000	3.250	7.000	10.000	5.719	16.21
4	14.00	S	EU	NC46	4.000	0.330	4.500	6.000	3.000	7.000	10.000	5.719	16.44
4-1/2	13.75	E	EU	NC50	4.500	0.271	5.000	6.625	3.750	7.000	10.000	6.063	15.90
4-1/2	16.60	E	EU	NC50	4.500	0.337	5.000	6.625	3.750	7.000	10.000	6.063	18.49
4-1/2	16.60	X, G	EU	NC50	4.500	0.337	5.000	6.625	3.750	7.000	10.000	6.063	18.86
4-1/2	16.60	S	EU	NC50	4.500	0.337	5.000	6.625	3.500	7.000	10.000	6.063	19.13
4-1/2	20.00	E	EU	NC50	4.500	0.430	5.000	6.625	3.625	7.000	10.000	6.063	22.13
4-1/2	20.00	X, G	EU	NC50	4.500	0.430	5.000	6.625	3.500	7.000	10.000	6.063	22.60
4-1/2	20.00	S	EU	NC50	4.500	0.430	5.000	6.625	3.000	7.000	10.000	6.063	23.07
4-1/2	16.60	E	IEU	NC46	4.500	0.337	4.688	6.250	3.250	7.000	10.000	5.719	18.39
4-1/2	16.60	X, G	IEU	NC46	4.500	0.337	4.688	6.250	3.000	7.000	10.000	5.719	18.63
4-1/2	16.60	S	IEU	NC46	4.500	0.337	4.688	6.250	2.750	7.000	10.000	5.719	18.84
4-1/2	20.00	E	IEU	NC46	4.500	0.430	4.688	6.250	3.000	7.000	10.000	5.719	22.14
4-1/2	20.00	X	IEU	NC46	4.500	0.430	4.688	6.250	2.750	7.000	10.000	5.719	22.64
4-1/2	20.00	G	IEU	NC46	4.500	0.430	4.688	6.250	2.500	7.000	10.000	5.719	22.83
4-1/2	20.00	S	IEU	NC46	4.500	0.430	4.688	6.250	2.250	7.000	10.000	5.719	23.00

Table C.1 (continued)

Designations ^a		Pipe body OD		Pipe wall thickness	Drill-pipe weld neck	Tool joint				RSC bevel dia.	Approx. mass ^c		
		Label 1	Label 2			Grade	Upset type	RSC type ^d	OD			Pin ID	Pin OD length
1	2	3	4	5	D_{dp} in See Table C.2	t in -12.5 %	D_{te}^b in max.	D in ± 0.031	d_p in $\begin{matrix} +0.016 \\ -0.031 \end{matrix}$	L_{pb} in ± 0.250	L_b in ± 0.250	D_t in ± 0.016	w_{dp} lb/ft Calculated
Internal-external upset, IEU													
5	19.50	E	IEU	NC50	5.000	0.362	5.125	6.625	3.750	7.000	10.000	6.063	21.37
5	19.50	X	IEU	NC50	5.000	0.362	5.125	6.625	3.500	7.000	10.000	6.063	21.89
5	19.50	G	IEU	NC50	5.000	0.362	5.125	6.625	3.250	7.000	10.000	6.063	22.14
5	19.50	S	IEU	NC50	5.000	0.362	5.125	6.625	2.750	7.000	10.000	6.063	22.58
5	19.50	E	IEU	5 1/2 FH	5.000	0.362	5.125	7.000	3.750	8.000	10.000	6.719	22.32
5	19.50	X, G	IEU	5 1/2 FH	5.000	0.362	5.125	7.000	3.750	8.000	10.000	6.719	22.58
5	19.50	S	IEU	5 1/2 FH	5.000	0.362	5.125	7.250	3.500	8.000	10.000	6.719	23.44
5	25.60	E	IEU	NC50	5.000	0.500	5.125	6.625	3.500	7.000	10.000	6.063	27.37
5	25.60	X	IEU	NC50	5.000	0.500	5.125	6.625	3.000	7.000	10.000	6.063	28.09
5	25.60	G	IEU	NC50	5.000	0.500	5.125	6.625	2.750	7.000	10.000	6.063	28.30
5	25.60	E	IEU	5 1/2 FH	5.000	0.500	5.125	7.000	3.500	8.000	10.000	6.719	28.32
5	25.60	X	IEU	5 1/2 FH	5.000	0.500	5.125	7.000	3.500	8.000	10.000	6.719	28.56
5	25.60	G	IEU	5 1/2 FH	5.000	0.500	5.125	7.250	3.500	8.000	10.000	6.719	29.13
5	25.60	S	IEU	5 1/2 FH	5.000	0.500	5.125	7.250	3.250	8.000	10.000	6.719	29.40
5-1/2	21.90	E	IEU	5 1/2 FH	5.500	0.361	5.688	7.000	4.000	8.000	10.000	6.719	23.81
5-1/2	21.90	X	IEU	5 1/2 FH	5.500	0.361	5.688	7.000	3.750	8.000	10.000	6.719	24.43
5-1/2	21.90	G	IEU	5 1/2 FH	5.500	0.361	5.688	7.250	3.500	8.000	10.000	6.719	25.28
5-1/2	21.90	S	IEU	5 1/2 FH	5.500	0.361	5.688	7.500	3.000	8.000	10.000	7.094	26.39

Table C.1 (continued)

Designations ^a			Pipe body OD	Pipe wall thickness	Drill-pipe weld neck	Tool joint				RSC bevel dia.	Approx. mass ^c	
Label 1	Label 2	Grade				Upset type	RSC type ^d	OD	Pin ID			Pin OD length
1	2	3	4	5	7	8	9	10	11	12	13	14
					t in -12.5 %	D_{te}^b in max.	D in ± 0.031	d_p in $+0.016$ -0.031	L_{pb} in ± 0.250	L_b in ± 0.250	D_f in ± 0.016	W_{dp} lb/ft Calculated
Internal-external upset, IEU												
5-1/2	24.70	E	IEU	5 1/2 FH	0.415	5.688	7.000	4.000	8.000	10.000	6.719	26.33
5-1/2	24.70	X, G	IEU	5 1/2 FH	0.415	5.688	7.250	3.500	8.000	10.000	6.719	27.77
5-1/2	24.70	S	IEU	5 1/2 FH	0.415	5.688	7.500	3.000	8.000	10.000	7.094	28.87
6-5/8	25.20	E	IEU	6 5/8 FH	0.330	6.938	8.000	5.000	8.000	11.000	7.703	27.57
6-5/8	25.20	X	IEU	6 5/8 FH	0.330	6.938	8.000	5.000	8.000	11.000	7.703	27.57
6-5/8	25.20	G	IEU	6 5/8 FH	0.330	6.938	8.250	4.750	8.000	11.000	7.703	28.63
6-5/8	25.20	S	IEU	6 5/8 FH	0.330	6.938	8.500	4.250	8.000	11.000	7.703	30.06
6-5/8	27.70	E	IEU	6 5/8 FH	0.362	6.938	8.000	5.000	8.000	11.000	7.703	29.43
6-5/8	27.70	X, G	IEU	6 5/8 FH	0.362	6.938	8.250	4.750	8.000	11.000	7.703	30.48
6-5/8	27.70	S	IEU	6 5/8 FH	0.362	6.938	8.500	4.250	8.000	11.000	7.703	31.91

NOTE See Figure B.1.

^a Designations are shown for the purpose of identification in ordering.

^b D_{te} is held to a maximum to ensure fit with elevator.

^c These values have been based on a drill-pipe-body length of 29.4 ft and are provided for information only. For other lengths, see API RP 7G for the method of calculation.

^d The RSC type indicates the size and style of the applicable rotary shouldered connection.

Table C.2 — Drill-pipe-body outside-diameter tolerances

Label 1	Tolerance
1	2
Pipe body	
≤ 4 in	± 0.031 in
> 4 in	+1.0 % D_{dp} -0.5 % D_{dp}
Drill-pipe-body behind the m_{eu}	
≥ 2- ³ / ₈ in to ≤ 3- ¹ / ₂ in	+0.094 in -0.031 in
> 3- ¹ / ₂ in to ≤ 5 in	+0.109 in -0.75 % D_{dp}
> 5 in to ≤ 6- ⁵ / ₈ in	+0.125 in -0.75 % D_{dp}

Table C.3 — Drill-pipe length, L

Dimensions in feet

1	Range 1	Range 2	Range 3
	2	3	4
Length, L , inclusive	20.0 to 23.0	29.0 to 32.0	40.0 to 45.0
Limitation for 95 % or order quantity ^a :			
Maximum variation	2.0	—	—
Minimum length	21.0	—	—
Limitation for 90 % of order quantity ^a :			
Maximum variation	—	2.0	3.0
Minimum length	—	30.0	40.0
^a Order quantity is the number of drill-pipe specified in the purchase agreement with the same item designations.			
NOTE See Figure B.1.			

Table C.4 — Chemical composition requirements

1	Phosphorus maximum %	Sulfur maximum %
	2	3
Pipe body: grade E	0.030	0.020
Pipe body: grades X, G and S	0.020	0.015
Tool joint	0.020	0.015

Table C.5 — Tensile requirements

	Yield strength		Tensile strength	Elongation
	psi		psi	%
	min.	max.	min.	min.
1	2	3	4	5
Drill-pipe-body				
Grade E	75 000	105 000	100 000	a
Grade X	95 000	125 000	105 000	a
Grade G	105 000	135 000	115 000	a
Grade S	135 000	165 000	145 000	a
Tool joint	120 000	165 000	140 000	13
a See 7.3.2.				

Table C.6 — Total gauge extension at the yield strength for drill-pipe-body

Drill-pipe-body grade	Total extension of gauge length %
1	2
E, X	0.5
G	0.6
S	0.7

Table C.7 — Minimum pipe-body elongation values

Tensile test specimen				Minimum elongation ^a in 2 in %			
Area <i>A</i> in ²	Specified wall thickness in			Grade			
	0.75 in wide strip	1.00 in wide strip	1.50 in wide strip	E	X	G	S
1	2	3	4	5	6	7	8
≥ 0.75	—	—	≥ 0.497	19	18	16	13
0.74	—	—	0.490 to 0.496	19	18	16	13
0.73	—	—	0.484 to 0.489	19	18	16	13
0.72	—	—	0.477 to 0.483	18	18	16	13
0.71	—	—	0.471 to 0.476	18	18	16	13
0.70	—	—	0.464 to 0.470	18	18	16	13
0.69	—	—	0.457 to 0.463	18	18	16	13
0.68	—	—	0.450 to 0.456	18	18	16	13
0.67	—	—	0.444 to 0.449	18	17	16	13
0.66	—	—	0.437 to 0.443	18	17	16	13
0.65	—	—	0.431 to 0.436	18	17	16	13
0.64	—	—	0.424 to 0.430	18	17	16	13
0.63	—	—	0.417 to 0.423	18	17	16	13
0.62	—	—	0.410 to 0.416	18	17	16	13
0.61	—	—	0.404 to 0.409	18	17	16	13
0.60	—	—	0.397 to 0.403	18	17	16	13
0.59	—	—	0.391 to 0.396	18	17	16	13
0.58	—	—	0.384 to 0.390	18	17	16	13
0.57	—	—	0.377 to 0.383	18	17	16	13
0.56	—	—	0.370 to 0.376	18	17	16	13
0.55	—	—	0.364 to 0.369	18	17	15	13
0.54	—	—	0.357 to 0.363	18	17	15	13
0.53	—	—	0.351 to 0.356	18	17	15	12
0.52	—	—	0.344 to 0.350	17	17	15	12
0.51	—	0.506 to 0.514	0.337 to 0.343	17	17	15	12
0.50	—	0.495 to 0.505	0.330 to 0.336	17	16	15	12
0.49	—	0.486 to 0.494	0.324 to 0.329	17	16	15	12
0.48	—	0.475 to 0.485	0.317 to 0.323	17	16	15	12
0.47	—	0.466 to 0.474	0.311 to 0.316	17	16	15	12
0.46	—	0.455 to 0.465	0.304 to 0.310	17	16	15	12
0.45	—	0.446 to 0.454	0.297 to 0.303	17	16	15	12
0.44	—	0.435 to 0.445	0.290 to 0.296	17	16	15	12
0.43	—	0.426 to 0.434	0.284 to 0.289	17	16	15	12
0.42	—	0.415 to 0.425	0.277 to 0.283	17	16	15	12

Table C.7 (continued)

Tensile test specimen				Minimum elongation ^a in 2 in %			
Area <i>A</i> in ²	Specified wall thickness in			Grade			
	0.75 in wide strip	1.00 in wide strip	1.50 in wide strip	E	X	G	S
1	2	3	4	5	6	7	8
0.41	—	0.406 to 0.414	0.271 to 0.276	16	16	15	12
0.40	—	0.395 to 0.405	0.264 to 0.270	16	16	15	12
0.39	—	0.386 to 0.394	0.257 to 0.263	16	16	14	12
0.38	—	0.375 to 0.385	0.250 to 0.256	16	16	14	12
0.37	—	0.366 to 0.374	—	16	16	14	12
0.36	—	0.355 to 0.365	—	16	15	14	12
0.35	—	0.346 to 0.354	—	16	15	14	11
0.34	0.447 to 0.460	0.335 to 0.345	—	16	15	14	11
0.33	0.434 to 0.446	0.326 to 0.334	—	16	15	14	11
0.32	0.420 to 0.433	0.315 to 0.325	—	16	15	14	11
0.31	0.407 to 0.419	—	—	16	15	14	11
0.30	0.394 to 0.406	—	—	15	15	14	11
0.29	0.381 to 0.393	—	—	15	15	14	11
0.28	0.367 to 0.380	—	—	15	15	14	11
0.27	0.354 to 0.366	—	—	15	14	13	11
0.26	0.340 to 0.353	—	—	15	14	13	11
0.25	0.327 to 0.339	—	—	15	14	13	11
0.24	0.314 to 0.326	—	—	15	14	13	11
0.23	0.301 to 0.313	—	—	15	14	13	11
0.22	0.287 to 0.300	—	—	15	14	13	10
0.21	0.274 to 0.286	—	—	14	14	13	10
0.20	0.260 to 0.273	—	—	14	14	13	10
0.19	0.247 to 0.259	—	—	14	14	13	10
0.18	0.234 to 0.246	—	—	14	14	12	10

^a The minimum elongation for either round-bar tensile specimens (0.35 in diameter with 1.40 in gauge length and 0.50 in diameter with 2.00 in gauge length) shall be that shown in this table for a cross-sectional area, *A*, of 0.20 in².

Table C.8 — Charpy V-notch longitudinal absorbed-energy requirements

Product element	Minimum average absorbed energy ft-lb			Minimum specimen absorbed energy ^a ft-lb		
	Specimen size, mm × mm			Specimen size, mm × mm		
	10 × 10	10 × 7.5	10 × 5	10 × 10	10 × 7.5	10 × 5
1	2	3	4	5	6	7
PSL-1 — Test temperature: +70 °F ± 5 °F						
Drill-pipe-body: grades X, G, S	40	32	22	35	28	19
Tool joint	40	32	22	35	28	19
Weld zone	12	10	—	10	8	—
SR19 — Test temperature: +70 °F ± 5 °F						
Drill-pipe-body: grade E	40	32	22	35	28	19
SR20 — Test temperature: +14 °F ± 5 °F						
Drill-pipe-body: all grades	30	24	20	22	18	15
Tool joint	30	24	20	22	18	15
Weld zone	12	10	—	10	8	—
SR24 — Test temperature: +70 °F ± 5 °F						
Weld zone	20	16	—	17	14	—
PSL-3 — Test temperature: −4 °F ± 5 °F						
Drill-pipe-body: all grades	74	59	41	59	47	32
Tool joint (box and pin)	40	32	22	35	28	19
Weld zone	31	25	—	24	19	—

^a The percent shear area shall be measured and reported for information only.

Table C.9 — Retention of records

Requirements	Reference (subclause)		
	Drill-pipe	Drill-pipe-body	Tool joints
1	2	3	4
Chemical properties:			
Heat analyses	—	7.7.1	—
Product analyses	—	7.7.2	8.7.2
Mechanical properties:			
Tensile tests	6.8	7.8	8.8
Hardness tests	6.9	—	8.9
Charpy tests	6.10	7.9	8.10
Transverse side-bend tests	6.11	—	—
NDE system capability verification	6.14.5	7.19.8	—
Calibration	Various	Various	Various

Table C.10 — Test frequency

	Chemical analysis	Tensile test	Charpy impact test	Outside surface hardness test	Through-wall hardness test	Side-bend test
1	2	3	4	5	6	7
Drill-pipe-body — Grade E — PSL-1						
< Label 1: 6-5/8	2 product per heat	1 per 400 or per lot ^a	—	—	—	—
≥ Label 1: 6-5/8	2 product per heat	1 per 200 or per lot ^a	—	—	—	—
Drill-pipe-body — Grade E — SR19						
< Label 1: 6-5/8	—	—	1 per 400 or per lot ^a	—	—	—
≥ Label 1: 6-5/8	—	—	1 per 200 or per lot ^a	—	—	—
Drill-pipe-body — Grades X, G and S — PSL-1						
< Label 1: 6-5/8	2 product per heat	1 per 200 or per lot ^a	1 per 200 or per lot ^a	—	—	—
≥ Label 1: 6-5/8	2 product per heat	1 per 100 or per lot ^a	1 per 100 or per lot ^a	—	—	—
Tool joints — PSL-1						
Pin	1 per heat (solid form)	1 per 200 or per lot ^a	1 per 200 or per lot ^a	—	1 per 200 or per lot ^b	—
Box	1 per heat (solid form)	—	1 per 200 or per lot ^a	—	1 per 200 or per lot ^a	—
Tool joints — PSL-3						
Pin	1 per heat (solid form)	1 per 200 or per lot ^a	—	Each pin	1 per 200 or per lot ^d	—
Box	1 per heat (solid form)	1 per 200 or per lot ^{a,c}	—	Each box	1 per 200 or per lot ^d	—
Weld line — PSL-1						
—	—	1 per 400 welds or per weld lot ^a	1 per 400 welds or per weld lot ^a	All welds at 3 locations 120° apart	1 per 400 welds or per weld lot ^a	1 per 400 welds or per weld lot ^a
Weld line — PSL-1, SR23						
—	—	1 per 200 welds or per weld lot ^a	1 per 200 welds or per weld lot ^a	All welds at 3 locations 120° apart	1 per 200 welds or per weld lot ^a	1 per 200 welds or per weld lot ^a
Weld line — PSL-2						
—	—	1 per 200 welds or per weld lot ^a	1 per 200 welds or per weld lot ^a	—	1 per 200 welds or per weld lot ^a	1 per 200 welds or per weld lot ^a
Weld line — PSL-3						
—	—	1 per 100 welds or per weld lot ^a	1 per 100 welds or per weld lot ^a	—	1 per 100 welds or per weld lot ^a	1 per 100 welds or per weld lot ^a

^a Whichever is the smaller quantity.

^b Only required if a tensile specimen cannot be obtained from the pin tool joint.

^c As close as practicable to the tool-joint shoulder unless otherwise specified in the purchase agreement.

^d This through-wall test is in addition to the test that is required for PSL-1.

Table C.11 — Calculated wall thickness required to machine longitudinal Charpy impact specimens

Specified outside diameter	Calculated wall thickness required to machine longitudinal Charpy impact specimens		
	in		
	Full-size	¾-size	½-size
1	2	3	4
2- ³ / ₈	0.450	0.352	0.253
2- ¹ / ₂	0.450	0.352	0.253
2- ⁵ / ₈	0.449	0.351	0.252
2- ³ / ₄	0.448	0.350	0.251
2- ⁷ / ₈	0.448	0.350	0.251
3	0.447	0.349	0.250
3- ¹ / ₈	0.446	0.348	0.249
3- ¹ / ₄	0.446	0.348	0.249
3- ³ / ₈	0.446	0.348	0.249
3- ¹ / ₂	0.445	0.347	0.248
3- ⁵ / ₈	0.445	0.347	0.248
3- ³ / ₄	0.444	0.346	0.247
3- ⁷ / ₈	0.444	0.346	0.247
4	0.444	0.346	0.247
4- ¹ / ₈	0.443	0.345	0.246
4- ¹ / ₄	0.443	0.345	0.246
4- ³ / ₈	0.443	0.345	0.246
4- ¹ / ₂	0.443	0.345	0.246
4- ⁵ / ₈	0.442	0.344	0.245
4- ³ / ₄	0.442	0.344	0.245
4- ⁷ / ₈	0.442	0.344	0.245
5	0.442	0.344	0.245
5- ¹ / ₈	0.442	0.344	0.245
5- ¹ / ₄	0.441	0.343	0.244
5- ³ / ₈	0.441	0.343	0.244

Table C.11 (continued)

Specified outside diameter	Calculated wall thickness required to machine longitudinal Charpy impact specimens		
	in		
	Full-size	¾-size	½-size
1	2	3	4
5-1/2	0.441	0.343	0.244
5-5/8	0.441	0.343	0.244
5-3/4	0.441	0.343	0.244
5-7/8	0.441	0.343	0.244
6	0.440	0.342	0.243
6-1/8	0.440	0.342	0.243
6-1/4	0.440	0.342	0.243
6-3/8	0.440	0.342	0.243
6-1/2	0.440	0.342	0.243
6-5/8	0.440	0.342	0.243
6-3/4	0.440	0.342	0.243
6-7/8	0.440	0.342	0.243
7	0.440	0.342	0.243
7-1/8	0.439	0.341	0.242
7-1/4	0.439	0.341	0.242
7-3/8	0.439	0.341	0.242
7-1/2	0.439	0.341	0.242
7-5/8	0.439	0.341	0.242
7-3/4	0.439	0.341	0.242
7-7/8	0.439	0.341	0.242
8	0.439	0.341	0.242
8-1/8	0.439	0.341	0.242
8-1/4	0.439	0.341	0.242
8-3/8	0.439	0.341	0.242
8-1/2	0.439	0.341	0.242
8-5/8	0.439	0.341	0.242
8-3/4	0.438	0.340	0.241
8-7/8	0.438	0.340	0.241
9	0.438	0.340	0.241

NOTE The above provides 0.020 in ID and 0.020 in OD machining allowances.

Table C.12 — Drill-pipe-mass code number

Designation		Wall thickness in	Mass code number
Label 1	Label 2		
1	2	3	4
2- ³ / ₈	6.65	0.280	2
2- ⁷ / ₈	10.40	0.362	2
3- ¹ / ₂	9.50	0.254	1
3- ¹ / ₂	13.30	0.368	2
3- ¹ / ₂	15.50	0.449	3
4	14.00	0.330	2
4- ¹ / ₂	13.75	0.271	1
4- ¹ / ₂	16.60	0.337	2
4- ¹ / ₂	20.00	0.430	3
5	19.50	0.362	2
5	25.60	0.500	3
5- ¹ / ₂	21.90	0.361	2
5- ¹ / ₂	24.70	0.415	3
6- ⁵ / ₈	25.20	0.330	2
6- ³ / ₈	27.70	0.362	3

NOTE Mass code number "2" denotes a standard weight for the drill-pipe size.

Table C.13 — Grade E drill-pipe-body dimensions, tolerances and masses

Designation ^a		Pipe-body dimensions					Upset dimensions ^{b,c}							
		<i>D_{dp}</i> in	<i>t</i> in	<i>d_{dp}</i> in	<i>w_{pe}</i> lb/ft	<i>D_{ou}</i> in	<i>d_{ou}</i> in	<i>L_{iu}</i> in	<i>m_{iu}</i> in	<i>L_{eu}</i> in	<i>m_{eu}</i> in	<i>L_{eu} + m_{eu}</i> in	<i>ε_w</i> lb	
Label 1	Label 2	See Table C.2	-12,5 %					$+1.500\text{ f}$ -0.500	min. g	min.	max.	max.		
1	2	3	4	5	6	7	8	9	10	11	12	13	14	15
Internal-upset (IU)														
4	14.00	4.000	0.330	3.340	12.93	4.250	2.750	1.750	2.000	—	—	—	—	4.60
4-1/2	13.75	4.500	0.271	3.958	12.24	4.750	3.375	1.750	—	—	—	—	—	5.20
External-upset (EU)														
2-3/8	6.65	2.375	0.280	1.815	6.26	2.656	1.815	—	—	1.500	1.500	—	4.000	1.80
2-7/8	10.40	2.875	0.362	2.151	9.72	3.219	2.151	—	—	1.500	1.500	—	4.000	2.40
3-1/2	9.50	3.500	0.254	2.992	8.81	3.938	2.992	—	—	1.500	1.500	—	4.000	2.60
3-1/2	13.30	3.500	0.368	2.764	12.31	3.938	2.602	2.250	2.000	1.500	1.500	—	4.000	4.00
3-1/2	15.50	3.500	0.449	2.602	14.63	3.938	2.602	—	—	1.500	1.500	—	4.000	2.80
4	14.00	4.000	0.330	3.340	12.93	4.563	3.340	—	—	1.500	1.500	—	4.000	5.00
4-1/2	13.75	4.500	0.271	3.958	12.24	5.063	3.958	—	—	1.500	1.500	—	4.000	5.60
4-1/2	16.60	4.500	0.337	3.826	14.98	5.063	3.826	—	—	1.500	1.500	—	4.000	5.60
4-1/2	20.00	4.500	0.430	3.640	18.69	5.063	3.640	—	—	1.500	1.500	—	4.000	5.60

Table C.13 (continued)

Designation ^a		Pipe body dimensions					Upset dimensions ^{b,c}								
		D_{dp} in	t in	d_{dp} in	m_{pe} lb/ft	D_{ou} in	d_{ou} in	L_{iu} in	m_{iu} in	L_{eu} in	m_{eu} in	$L_{eu} + m_{eu}$ in	ϵ_w lb		
Label 1	Label 2	See Table C.2	-12,5 %				$\pm 0.063^e$	$\begin{smallmatrix} +1.500^f \\ -0.500 \end{smallmatrix}$	min. ^g	min.	max.	max.			
1	2	3	4	5	6	7	8	9	10	11	12	13	14	15	
Internal-external upset (IEU)															
4-1/2	16.60	4.500	0.337	3.826	14.98	4.750	3.156	2.500	2.000	1.500	1.000	1.500	—	8.10	
4-1/2	20.00	4.500	0.430	3.640	18.69	4.781	3.000	2.250	2.000	1.500	1.000	1.500	—	8.60	
5	19.50	5.000	0.362	4.276	17.93	5.188	3.688	2.250	2.000	1.500	1.000	1.500	—	8.60	
5	25.60	5.000	0.500	4.000	24.03	5.188	3.438	2.250	2.000	1.500	1.000	1.500	—	7.80	
5-1/2	21.90	5.500	0.361	4.778	19.81	5.750	4.000	2.250	2.000	1.500	1.000	1.500	—	10.60	
5-1/2	24.70	5.500	0.415	4.670	22.54	5.750	4.000	2.250	2.000	1.500	1.000	1.500	—	9.00	
6-5/8	25.20	6.625	0.330	5.965	22.19	7.000	5.315	4.500	2.000	3.000	—	—	5.500	24.87	
6-5/8	27.70	6.625	0.362	5.901	24.21	7.000	5.315	4.500	2.000	3.000	—	—	5.500	24.00	

NOTE - See Figure B.6.

^a Designations are shown for the purpose of identification in ordering.

^b The specified upset dimensions do not necessarily agree with the bore and OD dimensions of finished weld-on product. Upset dimensions were chosen to accommodate the various bores of tool joints and to maintain a satisfactory cross-section in the weld zone after final machining of the product.

^c When specified in the purchase agreement, the length of upset for grade E drill-pipe may be the same as for grades X, G and S.

^d For internal-upset drill-pipe-body, the tolerance on the outside diameter of the upset, D_{ou} , shall be $\begin{smallmatrix} +0.125 \\ 0 \end{smallmatrix}$ in. A slight external upset within these tolerances is permissible.

^e Maximum taper on inside diameter of internal upset and internal-external upset is 0.250 in/ft on diameter.

^f L_{iu} tolerance for label 1: $\begin{smallmatrix} +2.000 \\ -0.500 \end{smallmatrix}$ in.

^g Label 1: 3-1/2 and label 2: 13.30 external-upset drill-pipe has a slight internal upset not illustrated in Figure B.6.

Table C.14 — Grades X, G and S drill-pipe-body dimensions, tolerances and masses

Designation ^a		Pipe-body dimensions				Upset dimensions ^b						
		D_{dp} in	t in	d_{dp} in	w_{pe} lb/ft	D_{0u} in	d_{0u} in	L_{iu} in	m_{iu} in	L_{eu} in	$L_{eu} + m_{eu}$ in	e_w lb
Label 1	Label 2	See Table C.2	-12.5 %			$+0.125$ ^c -0.031	± 0.063 ^d	$+1.500$ ^e -0.500	min.	min.	max.	
1	2	3	4	5	6	7	8	9	10	11	12	13
Internal-upset (IU)												
3-1/2	13.30	3.500	0.368	2.764	12.31	3.500	1.938	3.500	—	—	—	7.40
4	14.00	4.000	0.330	3.340	12.93	4.250	2.625	3.500	—	—	—	8.80
External-upset (EU)												
2-3/8	6.65	2.375	0.280	1.815	6.26	2.656	1.562	4.250	—	3.000	5.500	4.60
2-7/8	10.40	2.875	0.362	2.151	9.72	3.250	1.938	4.250	—	3.000	5.500	6.20
3-1/2	13.30	3.500	0.368	2.764	12.31	4.000	2.500	4.250	—	3.000	5.500	10.20
3-1/2	15.50	3.500	0.449	2.602	14.63	4.000	2.500	4.250	—	3.000	5.500	8.20
4	14.00	4.000	0.330	3.340	12.93	4.625	3.062	4.250	—	3.000	5.500	14.40
4-1/2	16.60	4.500	0.337	3.826	14.98	5.188	3.562	4.250	—	3.000	5.500	17.20
4-1/2	20.00	4.500	0.430	3.640	18.69	5.188	3.438	4.250	—	3.000	5.500	16.00
Internal-external upset (IEU)												
4-1/2	16.60	4.500	0.337	3.826	14.98	4.750	2.875	2.500	3.000	1.500	3.000	8.70
4-1/2	20.00	4.500	0.430	3.640	18.69	4.781	2.812	4.250	3.000	3.000	5.500	17.60
5	19.50	5.000	0.362	4.276	17.93	5.188	3.562	4.250	3.000	3.000	5.500	16.80
5	25.60	5.000	0.500	4.000	24.03	5.188	3.312	4.250	3.000	3.000	5.500	15.40
5-1/2	21.90	5.500	0.361	4.778	19.81	5.750	3.812	4.250	3.000	3.000	5.500	21.00
5-1/2	24.70	5.500	0.415	4.670	22.54	5.750	3.812	4.250	3.000	3.000	5.500	18.40
6-5/8	25.20	6.625	0.330	5.965	22.19	7.000	5.315	4.500	3.000	3.000	5.500	25.87
6-5/8	27.70	6.625	0.362	5.901	24.21	7.000	5.315	4.500	3.000	3.000	5.500	24.00
NOTE		See Figure B.6.										
<p>^a Designations are shown for the purpose of identification in ordering.</p> <p>^b The specified upset dimensions do not necessarily agree with the bore and OD dimensions of finished weld-on product. Upset dimensions were chosen to accommodate the various bores of tool joints and to maintain a satisfactory cross-section in the weld zone after final machining of the product.</p> <p>^c For internal-upset drill-pipe body, the tolerance on the outside diameter of the upset, D_{0u}, shall be $+0.125$₀ in. A slight external upset within these tolerances is permissible.</p> <p>^d Maximum taper on inside diameter of internal upset and internal-external upset is 0.250 in/ft on diameter.</p> <p>^e The L_{iu} tolerance for label 1: 6-5/8 drill-pipe is $+2.000$_{-0.500} in.</p>												

Table C.15 — Drill-pipe-body upset — Maximum permissible depth of imperfections (measured from the surface)

Item	Surface	Depth	Measurement notes
1	2	3	4
1	All surfaces from the planes as in items 2 and 3 below throughout the upset interval	12.5 %	Percentage of specified drill-pipe-body wall thickness; for non-linear imperfections; for all grades of drill-pipe-body
		12.5 %	Percentage of specified drill-pipe-body wall thickness; for linear imperfections; for grade E drill-pipe-body
		5 %	Percentage of specified drill-pipe-body wall thickness; for linear imperfections; for grades X, G, and S drill-pipe-body
2	On the external upset surface, from the end of the drill-pipe-body to a plane at a distance equal to the specified minimum dimension, L_{eu} , (Figure B.6) from the end of the drill-pipe body, the maximum permissible depth is as indicated by the requirement for maintaining dimension D_{0u} .		
3	On the internal upset surface, from the end of the drill-pipe-body to a plane at a distance equal to the specified minimum dimension, L_{iu} , (Figure B.6) from the end of the drill-pipe body, the maximum permissible depth is as indicated by the requirement for maintaining dimension d_{0u} .		
4	The minimum permissible drill-pipe-body wall thickness in the upset taper interval, and the maximum combined effect of coincident internal and external imperfections in all areas, shall not result in less than the minimum permissible pipe-body wall thickness.		
5	Elephant hide which shall be inspected as stated in 7.17.4 and in accordance with item 1 tolerances above.		

Table C.16 — Required inspection methods

Grade	Inspection method		
	Visual	Electromagnetic	Ultrasonic
1	2	3	4
E, X, G, S	R	A	A

R – Required.
A – One method or any combination of methods shall be used.

Table C.17 — Artificial reference indicators for the drill-pipe-body

Grade	Notch location		Notch orientation ^a		Notch dimensions		
	OD	ID	Long.	Trans.	Depth ^b	Max. length at full depth	Max. width
1	2	3	4	5	6	7	8
E, X, G	c	c	c	c	12.5	2	0.040
S	c	c	c	c	5.0	2	0.040

^a Notches shall be square or U-shaped according to ASTM E213. At the option of the drill-pipe manufacturer, notches may be oriented at such an angle as to optimize detection of anticipated defects.

^b Depth as a percentage of specified pipe-body wall thickness. The depth tolerance shall be $\pm 15\%$ of the calculated notch depth with a minimum notch depth of 0.012 in ± 0.002 in.

^c Required when using notches.

Annex D (normative)

Purchaser inspection

D.1 Inspection notice

Where the inspector representing the purchaser desires to inspect this product or witness a test, reasonable notice shall be given of the time at which the relevant inspection/tests are to be made.

D.2 Plant access

The inspector representing the purchaser shall comply with all health, safety and environmental rules of the manufacturer's facility.

The inspector representing the purchaser shall have unrestricted access at all times while work on the contract of the purchaser is being performed, to all parts of the manufacturer's works that concern the manufacture of the product ordered. The manufacturer shall afford the inspector all reasonable facilities to satisfy the inspector that the product is being manufactured in accordance with this International Standard. All inspections should be made at the place of manufacture prior to shipment, unless otherwise specified in the purchase agreement, and shall be conducted so as not to interfere unnecessarily with the operation of the works.

D.3 Compliance

The manufacturer is responsible for complying with all of the provisions of this International Standard. The purchaser may make any reasonable investigation necessary to be satisfied of compliance by the manufacturer and may reject any material that does not comply with this International Standard.

D.4 Rejection

Unless otherwise provided, material that shows defects on inspection or subsequent to acceptance at the manufacturer's works, or that proves defective when properly applied in service, may be rejected and the manufacturer so notified. If tests that require destruction of material are made, any product that is proven not to have met the requirements of this International Standard shall be rejected. Disposition of rejected product shall be a matter of agreement between purchaser and manufacturer.

Annex E (informative)

Supplementary requirements

E.1 General

This annex describes supplementary requirements that may be specified by the purchaser or agreed between purchaser and manufacturer. These requirements apply only when stated on the purchase agreement.

E.2 SR2 drill-pipe-body for grades E, X and G

E.2.1 Defects, imperfections and NDE

The drill-pipe-body shall meet the requirements for grade S for imperfections and defects, see 7.17 and, for non-destructive examination, see 7.19.

E.2.2 Marking

Drill-pipe-body tested to these supplementary requirements shall be paint-stencilled with the letters "SR2" at a location convenient to the manufacturer but near the grade marking.

E.3 SR15 drill-pipe — Test certificates

The drill-pipe manufacturer shall provide a certificate of inspection stating the ISO International Standard (or equivalent specification) and revision date thereof, to which the pipe was manufactured and containing the following data, as applicable, for each item for which this supplementary requirement is specified in the purchaser agreement:

- a) label 1, label 2, grade, range, RSC type, type of heat treatment and any other special requirements specified in the purchase agreement;
- b) chemical analyses (heat, product and re-check, as applicable) showing the mass per cent of all elements whose limits or reporting requirements are stipulated in this International Standard and any other elements used by the manufacturer to control the mechanical properties;
- c) test data for all tensile tests required by this International Standard, including yield strength, ultimate tensile strength and elongation; the type, size and orientation of specimens shall be shown;
- d) where impact testing is required by the International Standard, reported data for each test shall include
 - the absorbed-energy requirement,
 - the size, location and orientation of the test specimens,
 - the specified temperature at which the test was performed,
 - the absorbed energy measured for each test specimen,
 - the average absorbed energy,
 - the percent shear area for each test specimen (for information only);

- e) hardness test results (including test type and criteria and specimen location and orientation), where such testing is required;
- f) for pipe for which NDE is specified (either in the base specification, supplementary requirements or the purchaser agreement), the method of inspection employed (ultrasonic, electromagnetic or magnetic particle) and the type and size of the reference standard used;
- g) results of any other supplemental testing requirements specified in the purchase agreement;
- h) identification number allowing the product to be traced to the relevant documentation.

The certificate of inspection may include the statement of compliance in 6.17.1.

E.4 SR19 pipe body — Charpy V-notch impact toughness testing of grade E

E.4.1 Impact requirements

Grade E pipe body shall meet the impact requirements (see 7.3.4) and the corresponding testing requirements (see 7.9) of grades X, G and S, except that the testing frequency shall be as in E.4.2.

E.4.2 Frequency of testing

Three Charpy V-notch specimens representing one test shall be taken from one length of drill-pipe-body from each lot of 400 lengths or less for label 1 smaller than $6\frac{5}{8}$ and from each lot of 200 lengths or less for label 1: $6\frac{5}{8}$ provided that, in the case of heat-treated drill-pipe lengths, all lengths have received the same heat treatment.

E.4.3 Marking

Drill-pipe-body tested to these supplementary requirements shall be paint-stencilled with the letters “SR19” at a location convenient to the manufacturer but near the grade marking.

E.5 SR20 alternative low-temperature Charpy V-notch impact requirements

E.5.1 General

These requirements shall apply to the drill-pipe-body, the tool joints and the weld zones.

E.5.2 Alternative low temperature

For all grades, the Charpy impact testing shall be carried out at $-10\text{ °C} \pm 3\text{ °C}$ ($14\text{ °F} \pm 5\text{ °F}$) and shall meet the requirements of Table A.8 or Table C.8 for SR20.

For grade E, the impact testing shall be carried out at the frequency in Clause E.4.

At the manufacturer's option the test may be performed at a lower temperature provided that the absorbed energy requirements at $-10\text{ °C} \pm 3\text{ °C}$ ($14\text{ °F} \pm 5\text{ °F}$) are achieved.

E.5.3 Marking

Drill-pipe-body and tool joints tested to these supplementary requirements shall be paint-stencilled with the letters “SR20” at a location convenient to the manufacturer but near the grade marking.

E.6 SR23 weld zone — Lot size

The maximum number of welds in a lot shall be 200.

E.7 SR24 Charpy V-notch — Increased weld-zone requirements

E.7.1 Requirements

The Charpy impact tests shall be made at $+21\text{ °C} \pm 3\text{ °C}$ ($+70\text{ °F} \pm 5\text{ °F}$) and shall meet the requirements in Table A.8 or Table C.8.

E.7.2 Marking

Product tested to this supplementary requirement shall be paint-stencilled with the letters “SR24” at a location convenient to the manufacturer but near the grade marking.

Annex F (informative)

Procedures used to convert from USC units to SI units for drill-pipe

F.1 Background

The following procedures were adopted in this International Standard for converting units from the United States Customary (USC) system into the Système Internationale (SI).

F.2 General

F.2.1 Rounding

The last retained digit in a number was unchanged when the next digit was less than 5 and raised when it was greater than 5.

When the digit following the last retained digit was exactly 5 followed by all zeros, the last retained digit was unchanged if it was even, or was raised if it was odd.

F.2.2 Fractions

A fraction or a number with a fraction in USC units were converted to the full decimal equivalent in USC units without rounding. The full decimal equivalent in USC units were then converted to an SI value, N_m , expressed in millimetres, using Equation (F.1):

$$N_m = 25,4 \times N \quad (F.1)$$

where N is the full decimal equivalent, expressed in inches, of a USC fraction or a number with a fraction that has not been rounded.

The converted SI value, in millimetres, for the equivalent of a USC fraction or a number with a fraction is rounded to the appropriate number of places for the application.

F.2.3 Tolerances

Tolerances were calculated using Equation (F.1).

The USC value for the tolerance, except in the case of angular misalignment, was converted to the SI value based on the appropriate conversion factor.

The converted SI value for the tolerance, except in the case of angular misalignment, was rounded to the same number of decimal places as the SI value to which it was applicable.

F.3 Pipe dimensions

F.3.1 Outside diameter

The USC value for the outside diameter of pipe and couplings was converted to an SI value, D_m , expressed in millimetres, using Equation (F.2):

$$D_m = 25,4 \times D \quad (\text{F.2})$$

where D is the outside diameter, expressed in inches.

The converted SI value for the outside diameter of the pipe was rounded to the nearest 0,01 mm.

F.3.2 Wall thickness

The USC value for wall thickness was converted to the SI value, t_m , expressed in millimetres, using Equation (F.3):

$$t_m = 25,4 \times t \quad (\text{F.3})$$

where t is the wall thickness, expressed in inches.

The converted SI value for wall thickness was rounded to the nearest 0,01 mm.

F.3.3 Inside diameter

The SI value for the inside diameter of pipe, d_m , expressed in millimetres, is calculated (not converted) using Equation (F.4):

$$d_m = D_m - (2 \times t_m) \quad (\text{F.4})$$

where

D_m is the outside diameter, expressed in millimetres;

t_m is the wall thickness, expressed in millimetres.

The calculated SI value for the inside diameter of the pipe was rounded to the nearest 0,01 mm.

F.3.4 Diameters and lengths of upsets

The USC value for the diameter and the length of upsets was converted to the SI value, U_m , expressed in millimetres, using Equation (F.5):

$$U_m = 25,4 \times U \quad (\text{F.5})$$

where U is the upset dimension, expressed in inches.

The converted SI value for the diameter and the length of upsets was rounded to the nearest 0,01 mm.

F.4 Plain-end linear mass

The plain-end linear mass, $W_{m,pe}$, expressed in SI units of kilograms per metre, was calculated (not converted) using Equation (F.6):

$$W_{m,pe} = 0,024\ 661\ 5 \times (D_m - t_m) \times t_m \quad (\text{F.6})$$

where

D_m is the outside diameter, expressed in millimetres;

t_m is the wall thickness, expressed in millimetres.

The calculated SI value for plain-end linear mass was rounded to the nearest 0,01 kg/m.

F.5 Approximate linear mass

The USC value for approximate linear mass was converted to the SI value, w_m , expressed in kilograms per metre, using Equation (F.7):

$$w_m = 1,488\ 16 \times m \quad (\text{F.7})$$

where m is the linear mass, expressed in pounds per foot.

The converted SI value for nominal linear mass was rounded to the nearest 0,01 kg/m.

F.6 Tensile tests

F.6.1 Yield strength

The USC value for yield strength was converted to the SI value, $Y_{S,m}$, expressed in megapascals, using Equation (F.8):

$$Y_{S,m} = 0,006\ 894\ 76 \times Y_S \quad (\text{F.8})$$

where Y_S is the yield strength, expressed in pounds per square inch.

The converted SI value for yield strength was rounded to the nearest megapascal.

F.6.2 Tensile strength

The USC value for tensile strength was converted to the SI value, $T_{S,m}$, expressed in megapascals, using Equation (F.9):

$$T_{S,m} = 0,006\ 894\ 76 \times T_S \quad (\text{F.9})$$

where T_S is the tensile strength, expressed in pounds per square inch.

The converted SI value for tensile strength was rounded to the nearest megapascal.

F.6.3 Elongation

The value for elongation, e_m , expressed as a percentage of values, was calculated (not converted) using Equation (F.10):

$$e_m = 1944,0 \times A_m^{0,2} / U_m^{0,9} \quad (\text{F.10})$$

where

A_m is the cross-sectional area of the tensile-test specimen, expressed in square millimetres;

U_m is the specified tensile strength, expressed in megapascals.

The calculated SI value for elongation was rounded to the nearest 1,0 % for a value of 10,0 % and larger and to the nearest 0,5 % for a value less than 10,0 %.

F.7 Charpy impact energy

When the SI value for the impact-energy requirement was not determined by an equation (for example, as used in Table A.8 and other minimum requirements), the standard USC value was converted to the SI value, C_m , expressed in joules, using Equation (F.11):

$$C_m = 1,355\ 82 \times C \quad (\text{F.11})$$

where

C_m is the standard Charpy impact energy, expressed in Joules;

C is the standard Charpy impact energy, expressed in foot-pounds (e.g. 8 ft-lb, 15 ft-lb, 20 ft-lb, 30 ft-lb).

The converted standard SI value for energy was rounded to the nearest joule.

F.8 Temperature

The temperature in degrees Fahrenheit (USC) was converted to a temperature in degrees Celsius (SI) using Equation (F.12):

$$C = (F - 32) \times 5/9 \quad (\text{F.12})$$

where

C is the temperature, expressed in degrees Celsius;

F is the temperature, expressed in degrees Fahrenheit.

The converted SI values for temperatures were rounded to the nearest degree.

When the temperature being converted was over 600 °F, the number was rounded to the most rational value, e.g. rounded to the nearest 5 °C. For example, 750 °F converts to 399 °C but the rational conversion is 400 °C.

Annex G (normative)

Product specification levels

G.1 General

This annex describes product specification level (PSL) requirements for PSL-2 and PSL-3 that may be specified by the purchaser. Higher PSL requirements may be furnished at the option of the manufacturer. The requirements for PSL-2 and PSL-3 are in addition to those for PSL-1, which are the basis of this International Standard. All requirements for PSL-3 are in addition to requirements for PSL-2, except as otherwise indicated by PSL-3 requirements. Accordingly, in the body of this International Standard, clauses and subclauses that give additional PSL-3 requirements are identified only as PSL-3. Those clauses and subclauses that give PSL-2 requirements are identified as both PSL-2 and PSL-3 requirements.

G.2 Additional requirements

The additional requirements for PSL-2 and PSL-3 are specified in Table G.1.

Table G.1 — Additional requirements for PSL-2 and PSL-3

PSL	NDE	Documen- tation	CVN	m_{iu}	Max. tool-joint yield strength MPa (ksi)	Tool-joint (pin and box) surface hardness HBW	Tool-joint through-wall hardness variation	Test frequency
1	2	3	4	5	6	7	8	9
2	SR2	SR15	SR19	a, b	—	—	—	See Table A.10 or C.10 ^c
3	—	—	See Table A.8 or C.8	—	1 034 (150)	285 to 341	56 HBW or 6,0 HRC ^d	—

^a For drill-pipe-body, a taper length (measured parallel to the axis of the drill-pipe body) shall be calculated based on a 5° taper and dimensions d_{dp} and d_{ou} . If the length resulting from this calculation is greater than 101,6 mm (4.0 in), then the minimum m_{iu} shall be 101,6 mm (4.0 in). For grade E, if the length resulting from this calculation is less than 60 mm (2-³/₈ in), then the minimum m_{iu} shall be 60 mm (2-³/₈ in). For grades G, X, and S, if the length resulting from this calculation is less than 85 mm (3-³/₈ in), then the minimum m_{iu} shall be 85 mm (3-³/₈ in).

^b The radius at the transition from the m_{iu} to the pipe body ID shall not be less than 127 mm (5 in).

^c For drill-pipe-body and tool joints, a lot (as defined in 7.6.2 and 8.6.2) shall not contain more than one heat.

^d This hardness variation requirement is not applicable between quadrants of a ring or rings in an order.

G.3 Through-wall hardness testing of tool joints

G.3.1 Procedures

Hardness tests shall be performed at room temperature in accordance with ISO 6506-1 or ASTM E10 for Brinell hardness tests or ISO 6508-1 or in accordance with ASTM E18 for Rockwell hardness tests.

When testing using the Brinell method, one impression shall be made at each position OD, ID, and mid-wall(s).

When testing using the Rockwell method, three hardness impressions shall be made at each location OD, ID, and mid-wall(s) and averaged to give the mean hardness number at each location. The results of each hardness impression and the averages shall be reported to the nearest 0,1 HRC unit.

G.3.2 Hardness-test locations

Hardness testing of tool joints shall be carried out on a radial cross-section, taken at least one radius away from the end of the tool joint or blank (see Figure B.14). These tests may be made at the thickest point in the tool-joint material at the option of the manufacturer or when specified on the purchase agreement.

All four quadrants shall be tested. Testing on blocks is recommended rather than testing as a full ring to ensure ring overhang does not adversely affect the hardness test results.

When Rockwell testing is used, the first impression in each quadrant or test block shall be made near the centre of the test specimen to seat the test specimen. The result of this impression shall be ignored.

G.3.3 Hardness re-tests

When testing using the Brinell method, if any quadrant fails to meet the requirements, the lot shall be rejected. Re-testing is allowed as in 8.9.5.

When testing using the Rockwell method, if the difference between the maximum mean hardness number and the minimum mean hardness is greater than 6,0 HRC units, the lot shall be rejected. Before re-testing, the test surface shall be re-ground. If the difference between re-test mean hardness numbers does not exceed 6,0 HRC units, the lot shall be accepted.

If any re-test exceeds the maximum hardness variation, the lot of tool joints represented by the test piece shall be rejected. Rejected lots may be re-heat-treated as new lots.

G.4 Markings

Products meeting the PSL-2 requirements shall be marked L2 in the location specified in Clauses 6, 7 and 8, as applicable.

Products meeting the PSL-3 requirements shall be marked L3 in the location specified in Clauses 6, 7 and 8, as applicable.

Annex H (informative)

API monogram

H.1 General

The API monogram programme allows an API licensee to apply the API monogram to products. The API monogram programme delivers significant value to the international oil and gas industry by linking the verification of an organization's quality management system with the demonstrated ability to meet specific product specification requirements. The use of the monogram on products constitutes a representation and warranty by the licensee to purchasers of the products that, on the date indicated, the products were produced in accordance with a verified quality management system and in accordance with an API product specification.

When used in conjunction with the requirements of the API license agreement, API Spec Q1/ISO/TS 29001, in its entirety, defines the requirements for those organizations who wish to voluntarily obtain an API license to provide API monogrammed products in accordance with an API product specification.

API monogram programme licenses are issued only after an on-site audit has verified that the licensee conforms to the requirements described in API Spec Q1/ISO/TS 29001 in total and the requirements of an API product specification.

Purchasers/users are requested to report to API all problems with API monogrammed products. The effectiveness of the API monogram programme can be strengthened by purchasers/users reporting problems encountered with API monogrammed products. A non-conformance may be reported using the API non-conformance reporting system available at <https://ncr.api.org>. API solicits information on any new product that is found to be non-conforming with API-specified requirements, as well as field failures (or malfunctions) that are judged to be caused by either specification deficiencies or non-conformities with API-specified requirements.

For information on becoming an API monogram licensee, please contact API, Certification Programs, 1220 L Street, N. W., Washington, DC 20005 or call 202-962-4791 or send an e-mail to certification@api.org.

H.2 API monogram marking requirements

The following marking requirements apply only to those API licensees wishing to mark their product with the API monogram. The following marking shall be placed at the location shown in 6.15.4 c) or 7.20.2 d) or 8.13.2 d).

The complete API monogram consists of the following:

- a) spec 5DP;
- b) manufacturer's API licence number;
- c) API monogram.

The API monogram shall be applied only to products complying with the requirements of the specification and only by licensed manufacturers.

Bibliography

- [1] ISO 11960:2004, *Specification for Casing and Tubing, Eighth Edition, Petroleum and natural gas industries — Steel pipes for use as casing or tubing for wells*
- [2] API Std 5T1, *Standard on Imperfection Terminology*
- [3] API Spec Q1/ISO/TS 29001, *Specification for Quality Programs for the Petroleum, Petrochemical and Natural Gas Industry, Eighth Edition*
- [4] API Spec 5D, *Specification for Drill-pipe*
- [5] API Spec 7, *Specification for Rotary Drill Stem Elements*

