

INTERNATIONAL STANDARD

ISO 11943

First edition
1999-08-01

Hydraulic fluid power — On-line automatic particle-counting systems for liquids — Methods of calibration and validation

*Transmissions hydrauliques — Systèmes de comptage automatique
en ligne de particules en suspension dans les liquides — Méthode
d'étalonnage et de validation*



Reference number
ISO 11943:1999(E)

Contents	Page
1 Scope	1
2 Normative references	1
3 Terms and definitions	1
4 Units of measurements	1
5 Prerequisite	2
6 Test equipment	2
7 Accuracy of measuring equipment and test conditions	2
8 Off-line calibration procedure	3
9 Validation of on-line sample preparation equipment and determination of secondary calibration standard	3
10 On-line secondary calibration and verification procedure	6
11 On-line dilution system validation	10
12 Precautions	12
13 Identification statement	13
Annex A (informative) Typical on-line calibration and validation system design information guide	14
Annex B (informative) Hydraulic circuit design information guide for on-line counter adaptation to a Multi-pass test stand	16
Annex C (informative) Summary of ISO round robin study for on-line calibration and validation	20

© ISO 1999

All rights reserved. Unless otherwise specified, no part of this publication may be reproduced or utilized in any form or by any means, electronic or mechanical, including photocopying and microfilm, without permission in writing from the publisher.

International Organization for Standardization
Case postale 56 • CH-1211 Genève 20 • Switzerland
Internet iso@iso.ch

Printed in Switzerland

Foreword

ISO (the International Organization for Standardization) is a worldwide federation of national standards bodies (ISO member bodies). The work of preparing International Standards is normally carried out through ISO technical committees. Each member body interested in a subject for which a technical committee has been established has the right to be represented on that committee. International organizations, governmental and non-governmental, in liaison with ISO, also take part in the work. ISO collaborates closely with the International Electrotechnical Commission (IEC) on all matters of electrotechnical standardization.

International Standards are drafted in accordance with the rules given in the ISO/IEC Directives, Part 3.

Draft International Standards adopted by the technical committees are circulated to the member bodies for voting. Publication as an International Standard requires approval by at least 75 % of the member bodies casting a vote.

International Standard ISO 11943 was prepared by Technical committee ISO/TC 131, *Fluid power systems*, Subcommittee SC 6, *Contamination control and hydraulic fluids*.

Annexes A, B and C of this International Standard are for information only.

Introduction

In hydraulic fluid power systems, power is transmitted and controlled through a fluid under pressure within an enclosed circuit. The fluid is both a lubricant and a power-transmitting medium.

Reliable system performance requires control of the fluid medium. Qualitative and quantitative determination of particulate contaminant in the fluid medium requires precision in obtaining the sample and determining the size and distribution of the contamination.

Automatic particle counters are an accepted means for determining the size and distribution of particulate contamination in fluids. Individual instrument accuracy is established through calibration.

Automatic particle counters are being utilized on-line to eliminate the need for sample containers, to provide increased accuracy, and to provide for a more rapid access to particle count information. This International Standard establishes guidelines for calibration and validation of on-line automatic particle counters.

Hydraulic fluid power — On-line automatic particle-counting systems for liquids — Methods of calibration and validation

1 Scope

This International Standard establishes a calibration and validation process for the use of on-line, automatic particle counting of suspended particles in liquids. A primary use is in the Multi-pass filter test ISO 16889.

2 Normative references

The following normative documents contain provisions which, through reference in this text, constitute provisions of this International Standard. For dated references, subsequent amendments to, or revisions of, any of these publications do not apply. However, parties to agreements based on this International Standard are encouraged to investigate the possibility of applying the most recent editions of the normative documents indicated below. For undated references, the latest edition of the normative document referred to applies. Members of ISO and IEC maintain registers of currently valid International Standards.

ISO 1000:1992, *SI units and recommendations for the use of their multiples and of certain other units*.

ISO 1219-1:1991, *Fluid power systems and components — Graphic symbols and circuit diagrams — Part 1: Graphic symbols*.

ISO 4021:1992, *Hydraulic fluid power — Particulate contamination analysis — Extraction of fluid samples from lines of an operating system*.

ISO 5598:1985, *Fluid power systems and components — Vocabulary*.

ISO 11171:—¹⁾, *Hydraulic fluid power — Calibration of automatic particle counters for liquids*.

ISO 12103-1:1997, *Road vehicles — Test dust for filter evaluation — Part 1: Arizona test dust*.

ISO 16889:—²⁾, *Hydraulic fluid power — Filters — Multi-pass method for evaluating filtration performance of a filter element*.

3 Terms and definitions

For terms and definitions of terms, see ISO 5598.

4 Units of measurements

The international system of units (SI) is used in accordance with ISO 1000.

1) To be published. (Revision of ISO 4402:1991)

2) To be published. (Revision of ISO 4572:1981)

Throughout this International Standard, the use of $\mu\text{m(c)}$ means that particle size measurements are carried out using an automatic particle counter which has been calibrated in accordance with ISO 11171.

5 Prerequisite

It is assumed that users of this procedure are competent in the operation of their particular particle counter and filter test equipment. It is also important that proper sample handling techniques be utilized throughout the procedure.

6 Test equipment

6.1 Automatic particle counter(s) or particle counter with two independent sensors for liquids.

6.2 Calibration supplies, in accordance with ISO 11171.

6.3 ISO medium test dust (ISO MTD) in accordance with ISO 12103-1, category A3, dried at 110 °C to 150 °C for at least 1 h and for use in the test system, mixed in the test fluid, mechanically agitated, then dispersed ultrasonically with a power density of 3 000 W/m² to 10 000 W/m².

NOTE This standard test dust is used in ISO 16889 for filter test purposes. For availability of ISO MTD, contact the ISO secretariat service or national members of ISO.

6.4 Test fluid, as specified in ISO 16889.

6.5 On-line sample preparation equipment, for mixing and supplying secondary calibration and validation fluid, comprising

- a) a reservoir, pump, fluid conditioning apparatus and instrumentation which are capable of meeting the validation requirements of clause 9;
- b) a clean-up filter capable of providing an initial fluid contamination level less than 5 particles greater than 5 $\mu\text{m(c)}$ per millilitre;
- c) a configuration which will not alter the contaminant distribution over the anticipated test duration (refer to ISO 16889);
- d) fluid sampling sections in accordance with ISO 4021;
- e) a configuration which will supply contaminated fluid to the particle counters under constant flow and temperature within the limits of Table 1.

NOTE 1 A Multi-pass test rig (see ISO 16889) can be used provided it has been validated per clause 9 of this procedure.

NOTE 2 An alternative typical configuration which has proved to be satisfactory is given in annex A.

6.6 Hydraulic circuit, containing dilution equipment, if required, for on-line counter adaptation to the Multi-pass test stand.

For typical hydraulic circuit configurations which have proven to be satisfactory refer to annex B.

7 Accuracy of measuring equipment and test conditions

7.1 Utilize measuring equipment with an accuracy within the limits in Table 1.

Table 1 — Measuring equipment accuracy and test conditions

Test condition	SI Unit	Instrument accuracy (± of reading)	Allowed test condition variation
Flow	l/min	0,5 %	2 %
Kinematic viscosity	mm ² /s	1 %	2 %
Pressure	Pa (bar)	1 %	2 %
Temperature	°C	0,5 °C	1 °C
Time	s	0,05 s	0,1 s
Volume	l	0,5 %	1 %
Mass	g	0,1 mg	1 %

CAUTION — Maintaining the accuracy of test conditions to within the limits of Table 1 does not imply that by so doing the validation limits will be satisfied. It has been proven that the most useful way in attaining the validation requirements is by maintaining the accuracy of test conditions given in Table 1 along with using the proper particle counting procedures, etc.

8 Off-line calibration procedure

8.1 Conduct a sizing calibration on particle counters when new or after major service as suggested by the particle counter manufacturer or in accordance with ISO 11171.

8.2 Use the procedures specified in ISO 11171 to determine particle concentration limits of each particle counter and sensor or use the manufacturer's recommended levels obtained in a similar manner.

9 Validation of on-line sample preparation equipment and determination of secondary calibration standard (see Figure 1)

9.1 When two counters (sensors) are to be used, the procedure described in this clause need only be performed using one counter and sensor.

9.2 Use one particle counter and sensor calibrated in accordance with 8.1 and set to the cumulative mode and at least six different threshold settings over the particle size range of interest.

9.3 Adjust total fluid volume, expressed in litres, in sample preparation equipment to the desired level and measure within ± 1 %. Maintain fluid viscosity at $(15 \pm 0,3)$ mm²/s.

9.4 Use a clean-up filter to provide an initial fluid contamination level less than 5 particles greater than 5 µm(c) per millilitre.

9.5 Determine the contaminant concentration to be used for calibration and verification. The dust concentration should produce a maximum particle count at the lowest particle size of approximately 50 % of the particle counter concentration limit determined in 8.2.

9.6 Add the required quantity of ISO MTD, prepared in accordance with 6.3, to the reservoir and allow to circulate for approximately 15 min. Record the lot number of the ISO MTD.

9.7 Start the test by conducting on-line automatic particle counts (sample volumes of 25 ml are recommended) at 2 min intervals for 1 h or 30 intervals spaced evenly throughout the longest period of time that the system will be used.

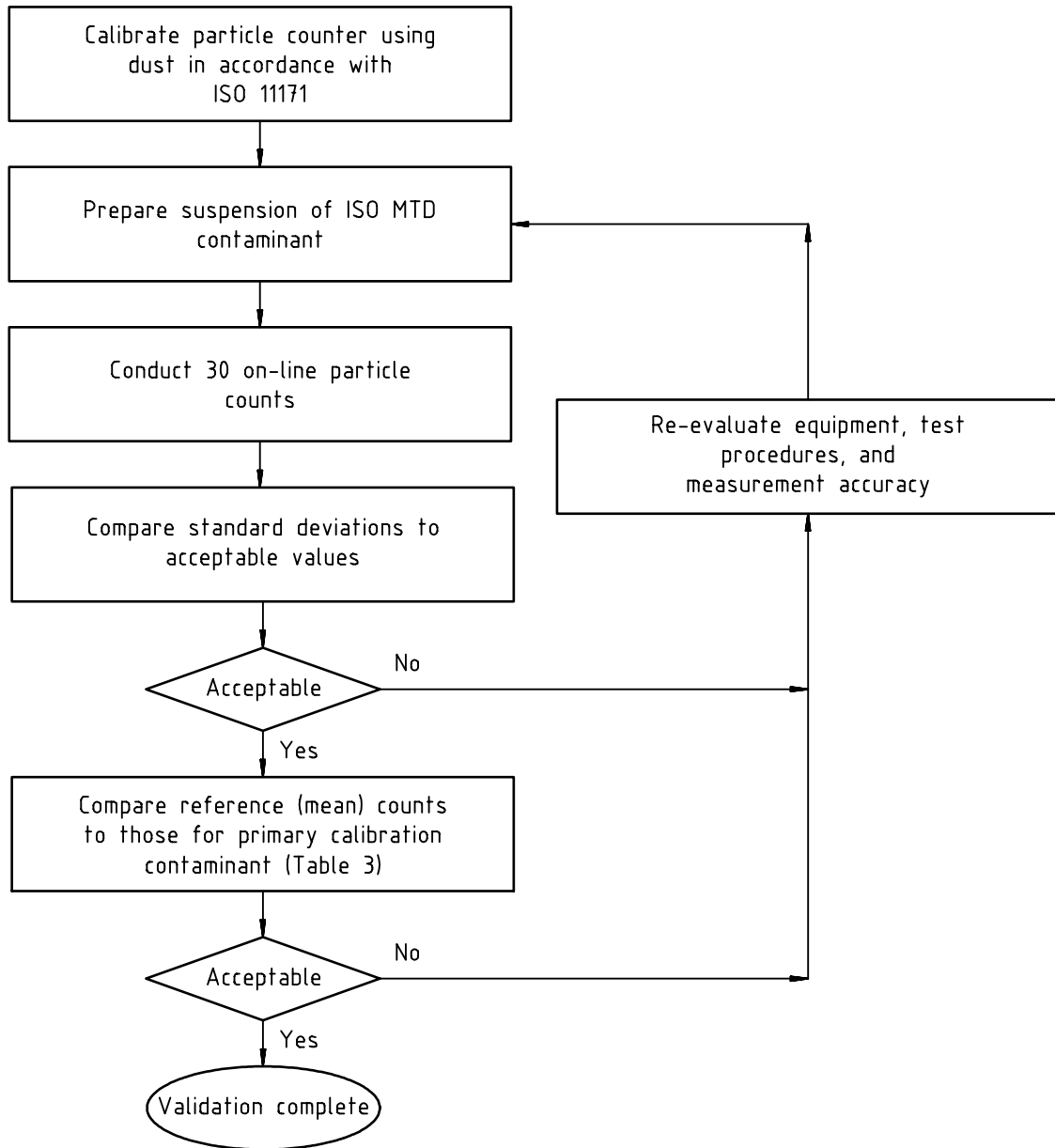

Figure 1 — Flowchart for the validation procedure of on-line sample preparation equipment and determination of secondary calibration standard

9.8 Complete Table 2 by filling in the required data for each of the raw particle counts observed. For each particle-size threshold setting, calculate the mean, \bar{x} , and also the standard deviation, σ , of all the counts using the following equation:

$$\sigma = \sqrt{\frac{n \sum_{i=1}^n (x_i^2) - \left(\sum_{i=1}^n x_i \right)^2}{n(n-1)}}$$

where

x_i is the particle concentration for each threshold setting for sample i ;

n is the total number of particle counts taken.

Table 2 — Secondary calibration dust data sheet

ISO MTD lot no.: _____ Concentration: _____ mg/l Particle count volume: _____ ml

Operator: _____ Date: _____ Particle counter model: _____

Particle counter serial no.: _____ Sensor model: _____

Sensor serial no.: _____ ISO 11171 primary calibration date: _____

	Number of particles					
Size, $\mu\text{m(c)}$ >						
Count 1						
Count 2						
Count 3						
Count 4						
Count 5						
Count 6						
Count 7						
Count 8						
Count 9						
Count 10						
Count 11						
Count 12						
Count 13						
Count 14						
Count 15						
Count 16						
Count 17						
Count 18						
Count 19						
Count 20						
Count 21						
Count 22						
Count 23						
Count 24						
Count 25						
Count 26						
Count 27						
Count 28						
Count 29						
Count 30						
Mean						
σ						
Acceptable σ						

9.9 Calculate the acceptable standard deviation for each particle size by using the following equation:

$$\sigma_{\text{acceptable}} = 2 \sqrt{\bar{x} + 0,0004 \bar{x}^2}$$

NOTE This acceptable standard deviation is based on 2 times the average standard deviation obtained in the round robin study (see annex C).

9.10 Accept the validation if the standard deviation for each particle size is less than or equal to the acceptable standard deviation for that size, then proceed to 9.13.

9.11 If the standard deviation for a given particle size exceeds the acceptable standard deviation, then re-evaluate the sample preparation equipment and procedures, the flow rates and particle count volumes for the on-line particle equipment. Take appropriate action and repeat the procedure from 9.3 to 9.10.

9.12 Calculate the particle concentration per ml for each particle size threshold setting by dividing the mean count by the fluid volume counted.

9.13 Convert the counts obtained in 9.12 to a number per μg (number per ml for 1 mg/l) by dividing by the sample concentration, in milligrams per litre. Record these reference counts in column 3 of Table 3.

9.14 Record, in column 2 of Table 3, the particle count (number per microgram) for the contaminant used for the primary calibration in 8.1.

9.15 Calculate and record, in column 4 of Table 3, the acceptable calibration limits for each particle size using the following equation:

$$\text{Calibration limit} = 0,37 (\text{calibration count in column 2 of Table 3})^{0,85}$$

NOTE These calibration limits for agreement are based on a 5 % variation in particle size together with 1 σ (Poisson distribution) as determined by the round robin study conducted (annex C).

9.16 Accept the equipment validation and reference counts if the reference counts are equal to the counts for primary calibration contaminant given in column 2 of Table 3 within 1,3 times the limits in column 4 of Table 3.

NOTE These reference counts define the particle size distribution of the secondary calibration contaminant (the specific lot number used in 9.5) and these counts will be used in clauses 10 and 11 for secondary calibration and verification.

9.17 When multiple counters or sensors are being used, calculate the allowable variation between sensors or counters for each particle size based on the following equation, and enter in column 5 of Table 3:

$$\text{Allowable variation} = 0,6 + 0,05 (\text{calibration count in column 2 of Table 3})$$

The maximum allowable particle count difference between counters shall be less than 10 % of the mean particle count.

NOTE The variation between counters is based on 2,5 σ (Poisson distribution) as determined by the round robin study.

10 On-line secondary calibration and verification procedure (see Figure 2)

10.1 Perform an on-line calibration verification after each primary calibration and at a maximum of six-month intervals or when particle count discrepancies are suspected or observed.

NOTE When two particle counters (sensors) are being used, calibration and verification should be carried out on one counter (sensor) using the procedures in 10.1 to 10.10 then the second counter (sensor) should be adjusted to match the first in accordance with 10.11.

Table 3 — Particle counts for ISO MTD

[All counts are cumulative and based on 1 µg (counts per millilitre for 1 mg/l) of ISO MTD.]

Col. 1	Col. 2	Col. 3	Col. 4	Col. 5
Particle size µm(c)	Primary calibration contaminant (see 9.14)	Reference counts for ISO MTD lot no. _____ (see 9.13)	± Calibration limits (see 9.15)	Variation allowed between counters (see 9.17)
> 1				
> 2				
> 3				
> 4				
> 5				
> 6				
> 7				
> 10				
> 12				
> 14				
> 15				
> 20				
> 30				

NOTE 1 The above calibration limits for agreement are based on a 5 % variation in particle size together with 1 σ (Poisson distribution) as determined by the round robin study.

NOTE 2 The variation between counters is based on 2,5 σ (Poisson distribution) as determined by the round robin with a maximum allowable particle count difference between counters of ± 10 % from the mean.

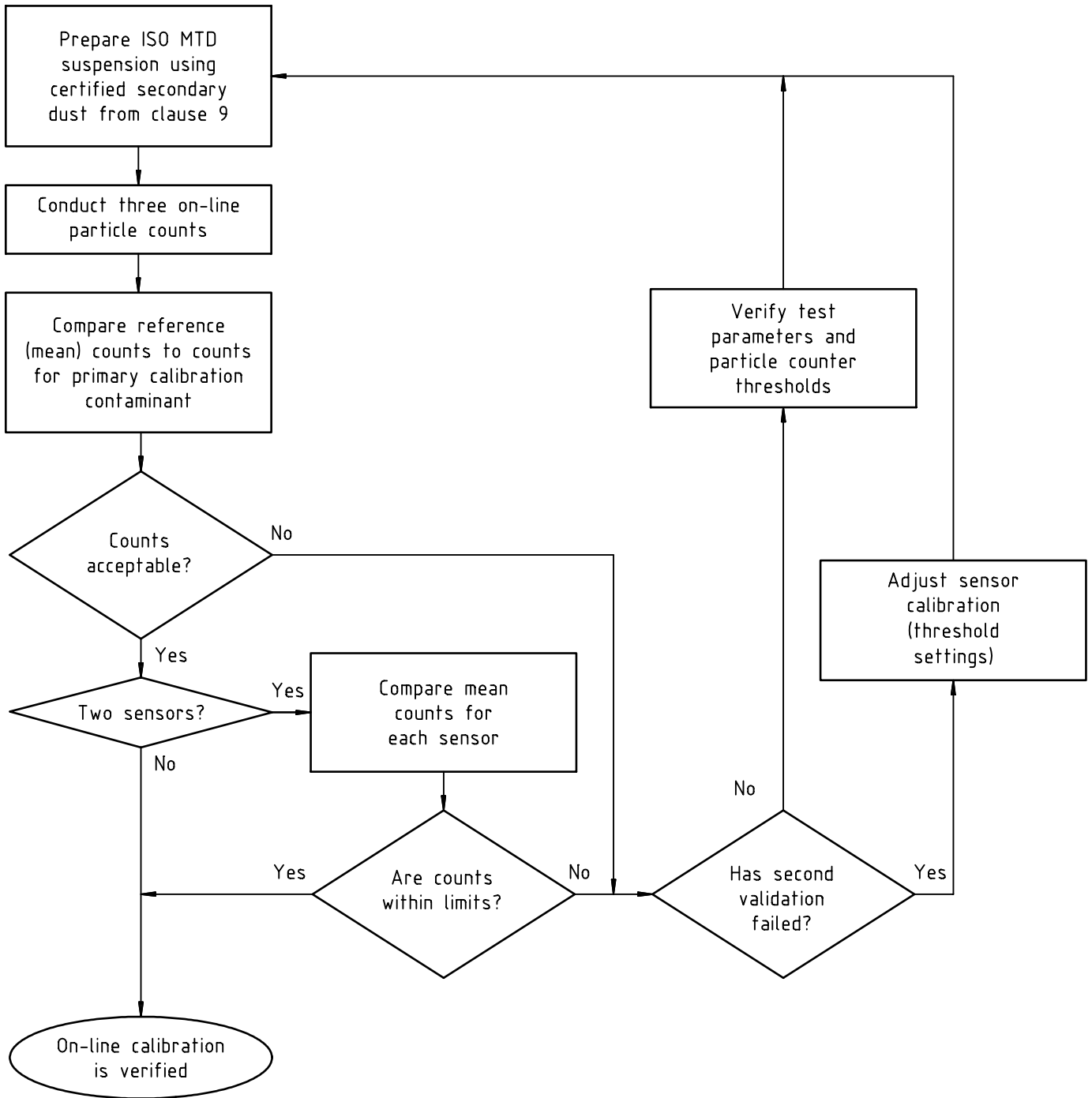

Figure 2 — Flowchart of procedure for on-line calibration verification

10.2 Use on-line sample preparation equipment which has been validated in accordance with clause 9 within the last 24 months.

10.3 Use only ISO MTD from the lot which has been certified as a secondary calibration lot in accordance with clause 9 (see Table 3).

10.4 Prepare a calibration verification suspension in accordance with the procedure described in 9.3 through 9.6.

10.5 Set the particle counter at desired particle size threshold settings, but only those for which reference particle counts have been established in accordance with clause 9 (see Table 3).

10.6 Allow the calibration verification suspension to pass through the particle counter sensor at the flow rate used for the primary calibration.

10.7 Perform an actual verification at several particle sizes covering the range over which the counter will be utilized.

NOTE Interpolation of threshold settings between verified points is allowed, however, extrapolation is never allowed.

10.8 Obtain a minimum of three consecutive on-line particle counts (after the counts have stabilized).

10.9 Calculate the average counts per microgram (particles per millilitre for 1 mg/l) for each particle size threshold setting by dividing the average count by the sample volume counted (ml) and the sample concentration (mg/l). Record the value obtained in Table 4.

10.10 All particle counts obtained in 10.9 should be equal to the reference counts in column 3 of Table 3, plus or minus the calibration limits in column 4 of Table 3, for each particle size counted.

NOTE The above calibration limits for agreement are based on a 5 % variation in particle size together with 1 σ (Poisson distribution) as determined by the round robin.

10.11 When both upstream and downstream counters (sensors) are being used, the second sensor should be calibrated using the same calibration-verification suspension as the first by adjusting the threshold settings of the second counter (sensor) such that the average counts per microgram (also recorded in Table 4) match the average counts for the first counter (sensor) within the allowable variation given in column 5 of Table 3 for each particle size counted.

NOTE It is recommended that the procedure in this subclause be repeated with sensor locations switched (upstream versus downstream).

10.12 If the particle counts obtained in 10.9 are within the limits set, verification is complete and proceed to clause 11.

10.13 If the particle counts obtained in 10.9 are outside the limits set, after taking corrective action, prepare another independent secondary calibration suspension and repeat the verification procedure described in 10.4 through 10.12.

Ensure that:

- a) the proper sensor flowrate is being used;
- b) the particle size threshold settings are correct;
- c) the fluid is completely degassed;
- d) the sample weights, volumes, etc. are correct.

10.14 If the particle counts from the verification obtained in 10.13 are still outside the limits set, adjust the particle counter calibration (threshold settings) by following the procedure specified in ISO 11171 except using the secondary calibration fluid supplied on-line along with the reference counts specified in column 3 of Table 3.

10.15 Conduct a calibration verification by repeating the procedure described in 10.4 through 10.12.

Table 4 — Data sheet for calibration verification

ISO MTD lot no.: _____ Concentration: _____ mg/l Particle count volume: _____ ml
 Operator: _____ Date: _____ Particle counter model: _____
 Particle counter serial no.: _____ ISO 11171 primary calibration date: _____

Size, $\mu\text{m(c)}$ >	Particle counts					
Upstream sensor: Model and S/N: _____ _____						
Count 1						
Count 2						
Count 3						
Average						
Average/ μg (10.9)						
Downstream sensor: Model and S/N: _____ _____						
Count 1						
Count 2						
Count 3						
Average						
Average/ μg (10.9)						

11 On-line dilution system validation (see Figure 3)

11.1 Perform a validation of the on-line dilution system, where used, at the same frequency as calibration verification.

11.2 Use dilution fluid which has been filtered to a cleanliness level of less than 5 particles greater than $5 \mu\text{m(c)}$ per millilitre, unless it can be established that a higher level will not add more than 1 % error to the resulting particle counts.

11.3 Validate first at the minimum dilution factor to be used.

11.4 Prepare an ISO MTD secondary calibration suspension in accordance with 9.3 to 9.6 but at a level equal to (50 ± 10) % of the concentration limits found in 8.2 times the dilution factor selected.

NOTE As an example, for a $2 \times$ dilution factor (1 part diluent:1 part suspension), use a sample concentration equal to 2 times 50 % of the counter concentration limit.

11.5 Set the particle counter(s) at a minimum of six particle size threshold settings covering the range of interest.

11.6 Using the dilution factor selected, obtain a minimum of three consecutive one-minute particle counts (after the counts have stabilized) for each sensor and calculate the average count of the diluted sample for each particle size.

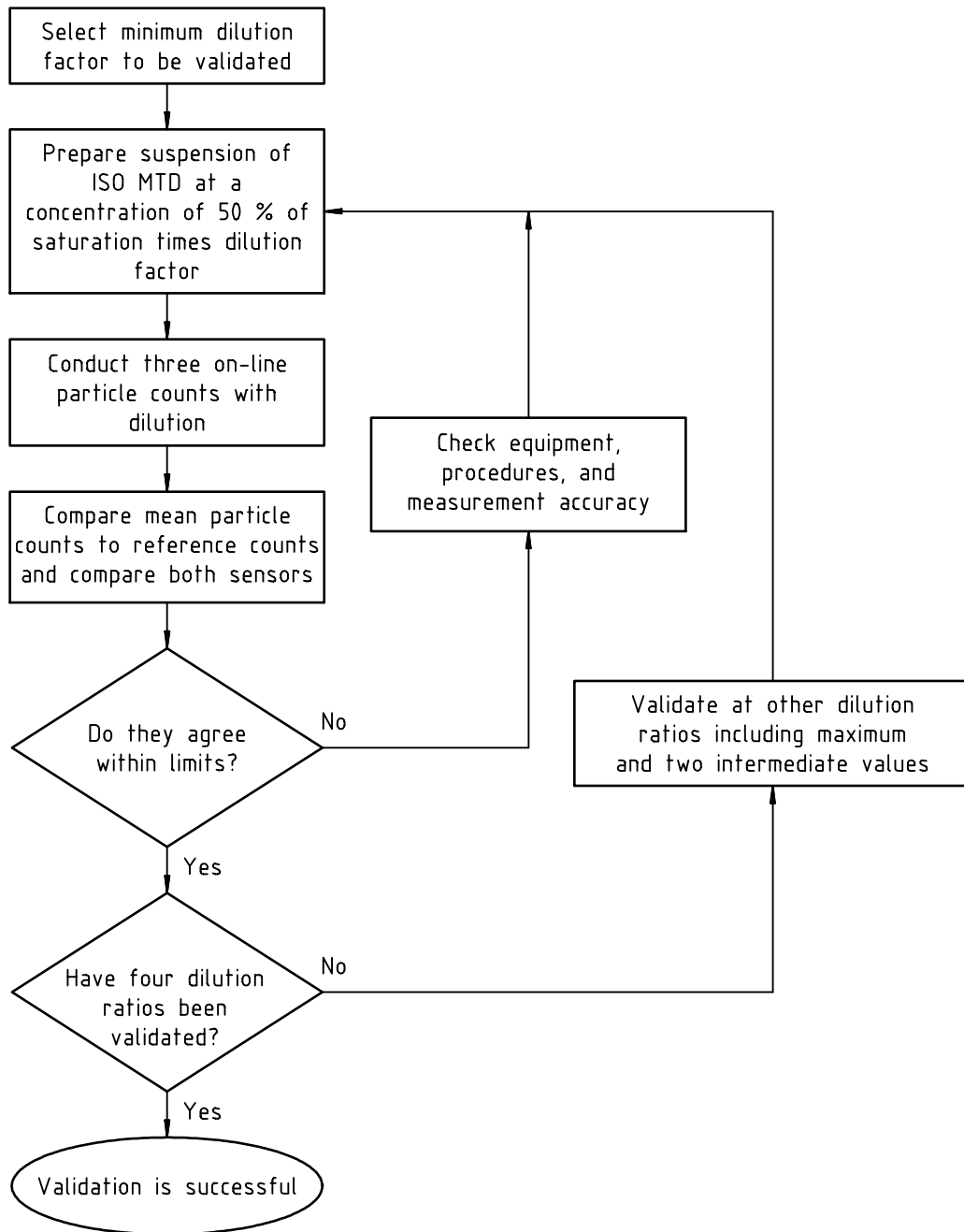

Figure 3 — Flowchart of the procedure for on-line dilution system validation

11.7 Calculate the average counts per millilitre for each particle size threshold setting, dividing the average count by the fluid volume counted, in millilitres.

11.8 Convert the counts obtained in 11.7 to a number per microgram by dividing by the sample concentration (mg/l) and multiplying by the dilution factor. Record in Table 5. Use separate data sheets for both upstream and downstream sensors where used.

11.9 All particle counts obtained in 11.8 should be equal to the reference counts in column 3 of Table 3, plus or minus the calibration limits in column 4 of Table 3, for each particle size counted. In addition, when upstream and downstream counters are being used, the average counts from the two counters (sensors) shall agree within the allowable variation given in column 5 of Table 3, for each particle size counted.

11.10 Repeat the procedures given in 11.4 to 11.9 at the maximum dilution factor to be used and at least two other intermediate dilution factors within the total dilution range of the system.

12 Precautions

12.1 On-line particle counting using ISO MTD for particle sizes greater than 40 $\mu\text{m(c)}$ requires extreme caution to ensure against particle settling. Calibration at the maximum particle sizes to be used shall be verified on-line (see clause 10).

12.2 Testing coarse filters with on-line counters requires higher dilution factors which necessitates the use of higher-accuracy flow measurement.

12.3 Dilution is required when particle counter concentration limits are exceeded. High concentrations of undetected particles may influence particle counts at measured sizes and higher dilution factors should be used under these conditions.

12.4 When on-line dilution is required, the dilution fluid should be the same fluid type as the test fluid to be counted.

12.5 The presence of free water or air in the test fluid to be analyzed will have a detrimental effect on results. Precautions shall be taken to eliminate these variables.

12.6 Isolate the particle counter sensors from mechanical vibration to prevent vibration-induced errors.

12.7 Electrically isolate the particle counters from other large equipment to prevent electrical noise influences.

12.8 Flow pulsations due to pump ripple may cause erroneous particle counts. Damping can be provided by small accumulators if they are included in the system verification.

12.9 Minimize all line lengths and maximize flow rates to result in low lag times (the time from the sample being extracted from the Multi-pass test stand until it is sensed by the particle counter). A count lag time of less than 30 s should be obtainable. Lag times of upstream and downstream sensors should be within 10 s of one another.

12.10 Valve adjustment should be kept to a minimum during operation to reduce errors due to particle generation by the valve.

12.11 Systematically back-flush each sensor to help insure that they are not plugged or partially blocked. Plugged or partially blocked sensors will cause erroneous particle counts and not all particle-counting equipment have built-in or reliable indicators to show that this condition is occurring.

Table 5 — Data sheet for validation of on-line dilution equipment

ISO MTD lot no.: _____ Particle count volume: _____ ml Date: _____

Is this sensor to be located upstream or downstream of the test filter? _____

Size, $\mu\text{m(c)}$ >	Particle counts					
Concentration: _____ mg/l Dilution factor: _____						
Count 1						
Count 2						
Count 3						
Average/ μg (11.8)						
Concentration: _____ mg/l Dilution factor: _____						
Count 1						
Count 2						
Count 3						
Average/ μg (11.8)						
Concentration: _____ mg/l Dilution factor: _____						
Count 1						
Count 2						
Count 3						
Average/ μg (11.8)						
Concentration: _____ mg/l Dilution factor: _____						
Count 1						
Count 2						
Count 3						
Average/ μg (11.8)						

13 Identification statement

On-line particle counting systems calibrated and verified in accordance with ISO 11943:1999, *Hydraulic fluid power — On-line automatic particle-counting systems for liquids — Methods of calibration and validation*.

Annex A (informative)

Typical on-line calibration and validation system design information guide

A.1 General

A.1.1 On-line calibration and validation requires a validation procedure to determine the acceptability of the equipment to perform the desired function.

A.1.2 It is intended that this annex provide some basic guidance in constructing equipment which will meet the validation requirements of this International Standard.

A.1.3 The reader is cautioned that this annex provides only guidelines for construction and in no way guarantees successful validation of the equipment.

A.2 On-line sample preparation equipment

The schematic of a typical set-up is shown in Figure A1.

A.2.1 Lines

All lines should be sized for turbulent mixing flow and long straight runs should be avoided.

A.2.2 Fittings

Fittings should not have internally exposed threads or lips which may be contaminant traps.

A.2.3 Lines and fittings

Lines and fittings should be arranged to eliminate dead flow zones and where possible, vertical runs are preferable to horizontal.

A.2.4 Valves

Ball valves are preferable to other types of valves as they are not contaminant traps and have a self-cleaning action. The valves should only be used in the full on or off positions and not for flow control.

A.2.5 Reservoir

The reservoir with a small volume, typically less than 10 l, should be constructed with a conical bottom displaying an included angle of not more than 90° with the entering test fluid diffused below the fluid surface. Note that small reservoir volumes may cause a problem in accurately weighing the required quantity of test dust.

A.2.6 Clean-up filter

The system clean-up filter shall be capable of providing the required initial system contamination level. A filter rated at $\leq 4,5 \mu\text{m}(c)$ ($\beta = 75$) is recommended.

A.2.7 Heat exchanger/heater

Depending upon the system design, cooling or heating of the system fluid may be required. A conventional shell-tube type heat exchanger with oil flowing through the tubes, or a reservoir with a double jacket in which a temperature-controlled fluid is circulated, is recommended for cooling or heating the test fluid. This is to reduce the possibility of particle sedimentation.

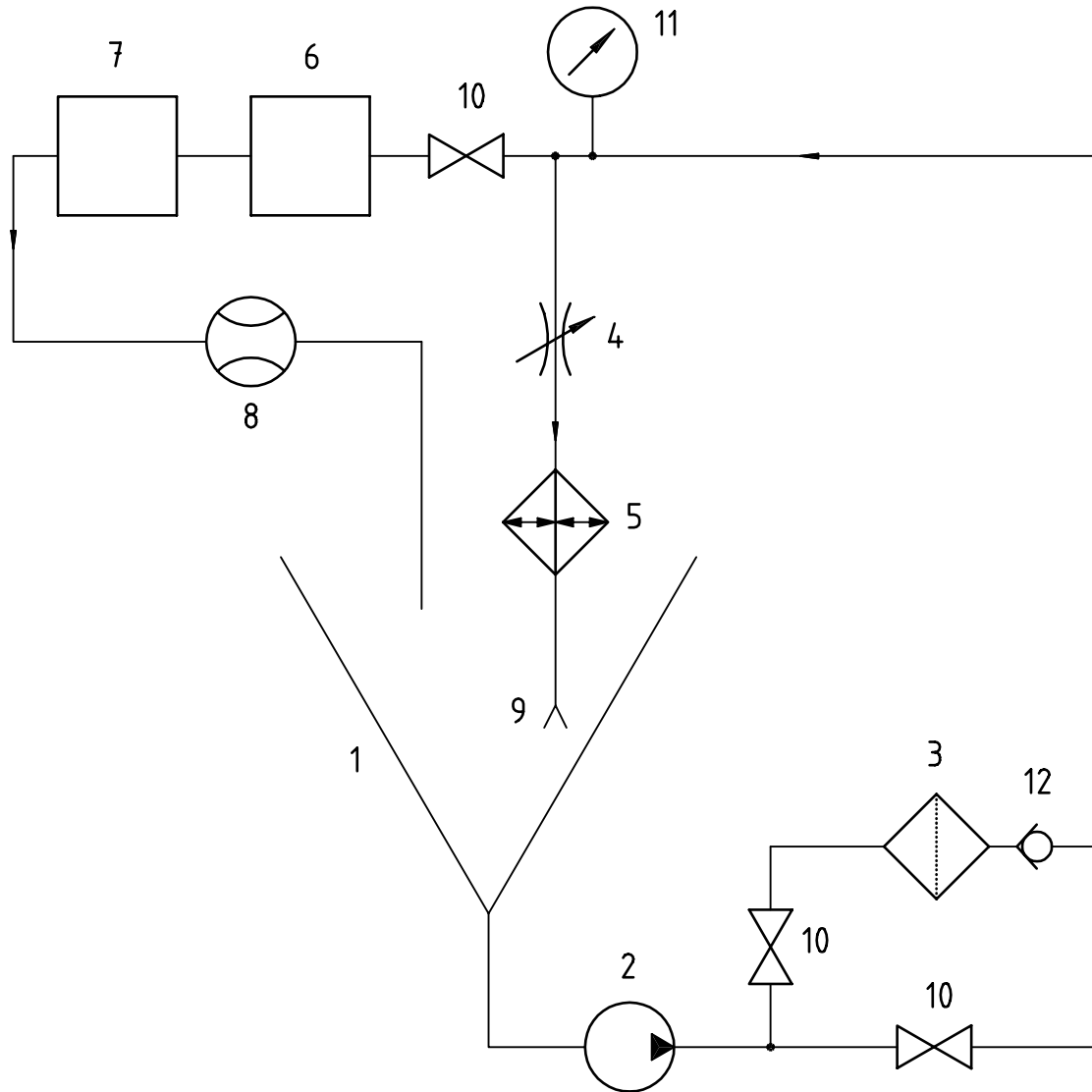

Key

- | | |
|--|--|
| 1 Conical reservoir (60° to 90° included angle) with precisely controlled volume | 7 Automatic particle counter sensor |
| 2 Centrifugal pump | 8 Flow meter |
| 3 Clean-up filter | 9 Flow diffuser |
| 4 Back-pressure valve | 10 Ball valve (not to be used for flow regulation) |
| 5 Heater / heat exchanger | 11 Pressure gauge |
| 6 Automatic particle counter sensor | 12 Check valve |

NOTE Calibration stand can be made portable (on wheels) so it can be brought to the on-line automatic particle counters as required for calibration and/or verification.

CAUTION — Two sensors in series may cause problems due to cavitation if the pressure drop in the first sensor is too high.

Figure A.1 — Example of a system for on-line calibration and validation

Annex B (informative)

Hydraulic circuit design information guide for on-line counter adaptation to a Multi-pass test stand

B.1 General

B.1.1 On-line particle counting (with or without dilution) during a Multi-pass test requires adaptation to the Multi-pass test stand and pre-test validation of the set-up to determine the acceptability of the equipment to perform the desired function.

B.1.2 It is intended that this annex provide some basic guidance in constructing equipment which will meet the validation requirements of this International Standard.

B.1.3 The reader is cautioned that this annex provides only guidelines for construction and in no way guarantees successful validation of the equipment.

B.1.4 Schemas of three typical set-ups which have been proven to be successful are shown in Figures B.1 to B.3.

B.1.5 The system component design guide for the on-line sample preparation equipment, given in annex A, should be followed for the on-line counting and dilution system.

.....

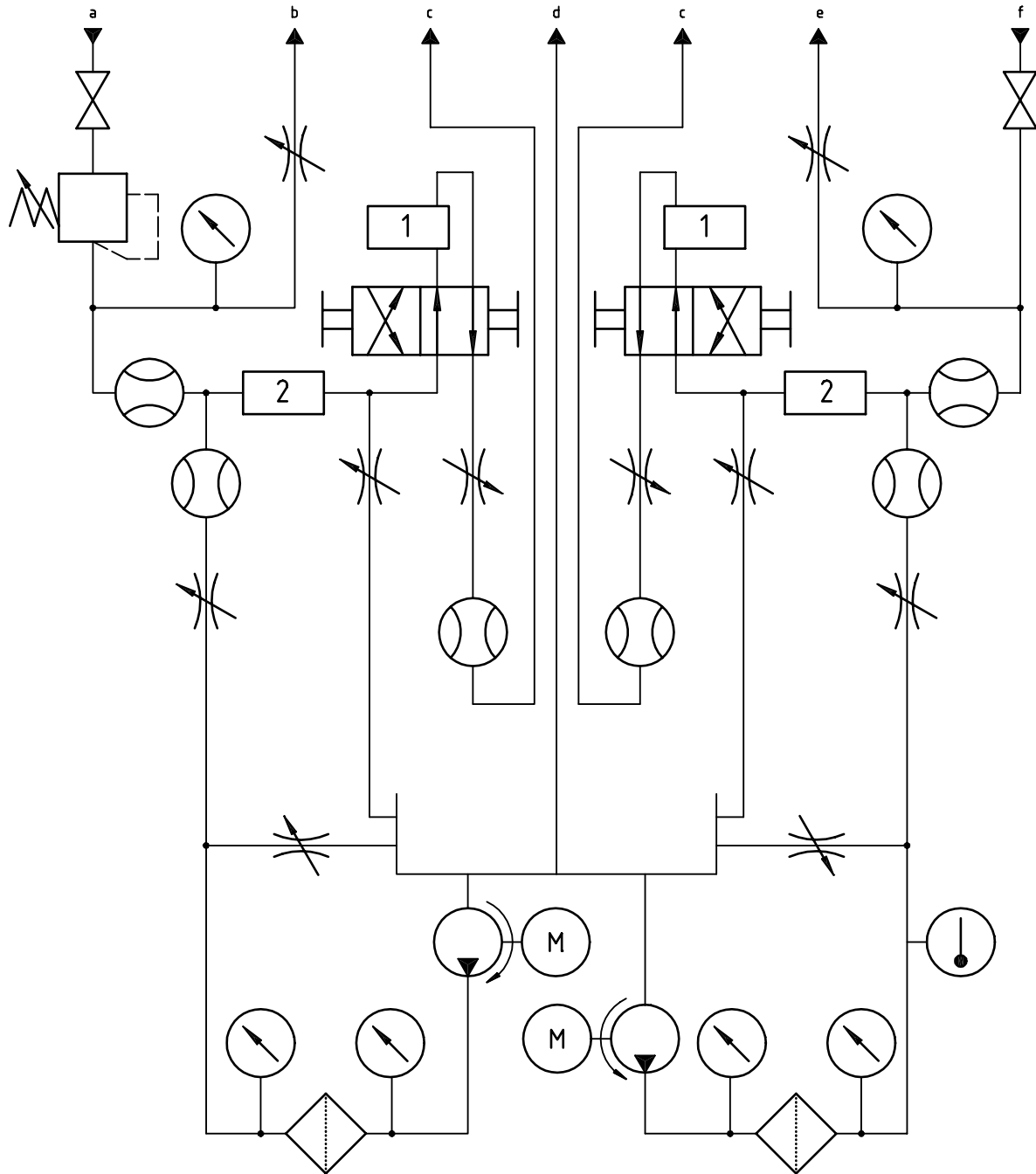

- a Upstream sample
- b Upstream return
- c Sensor return
- d Overflow
- e Downstream return
- f Downstream sample

Key

- 1 Sensor
- 2 Mixer

Figure B.1 — Example of the circuit number 1 for an on-line counter adaptation to the Multi-pass test stand

Serial dilution 1 000 × (as shown in Figure B.2)

Suggested: pumps 4 (20 to 50) ml/min — Sample pumps 3 (180 to 240) ml/min — Dilution

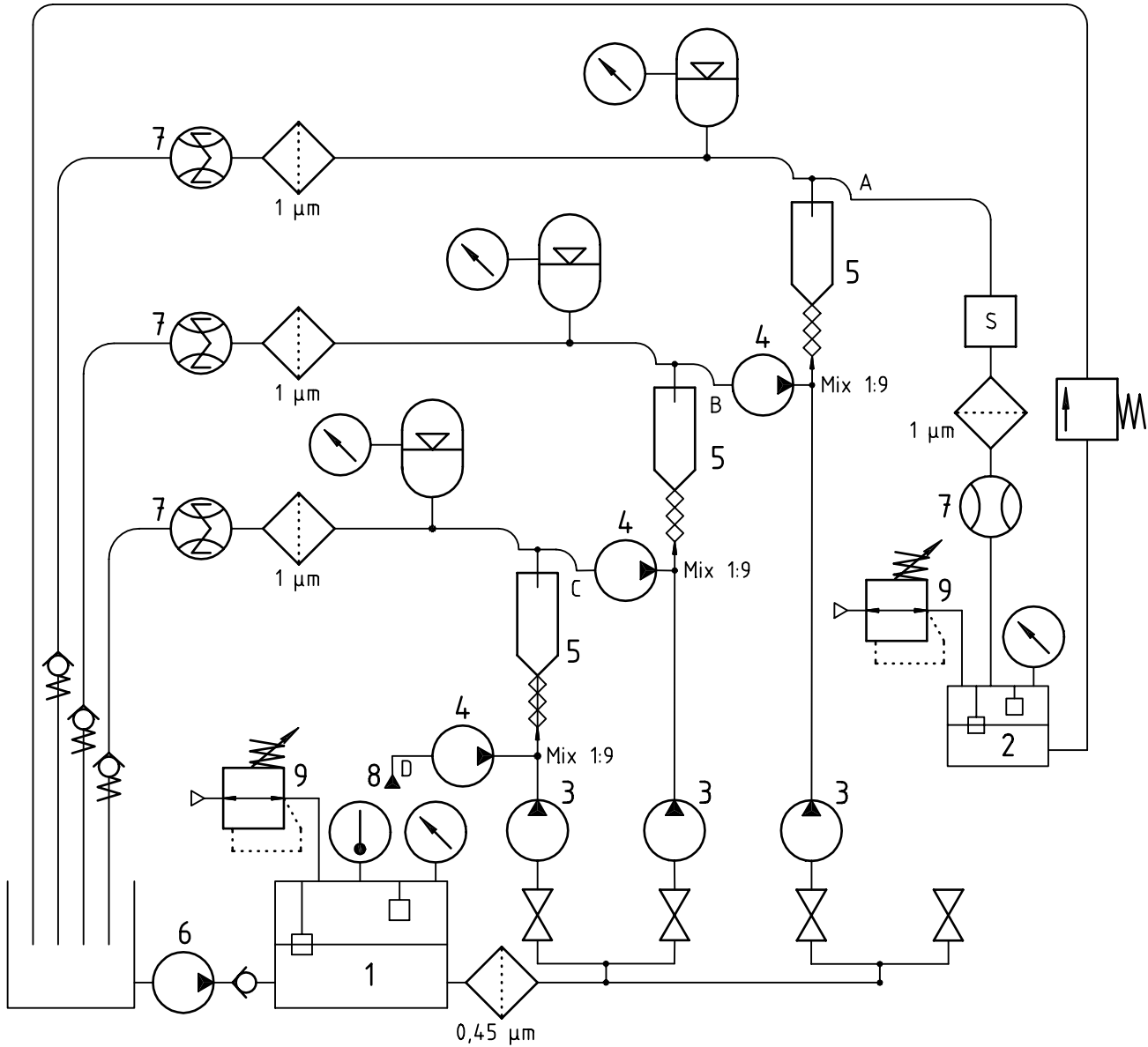

Key

- | | |
|--|-------------------------------------|
| 1, 2 Automatic levelled chambers (pressurized) | 7 Totalizing micro-oval flow meters |
| 3 Tandem peristaltic dilution pumps | 8 From Multi-pass |
| 4 Tandem peristaltic sample pumps | 9 Regulated air |
| 5 Static mixers and expanded chamber | S Sensor |
| 6 Transfer pump (automatic demand) | |

NOTE Systems as shown are required for upstream and downstream sampling.
 Pick off point A may be moved to point B or C to give 100 × or 10 × dilution.
 Pressure points A, B, C and D to be the same.

Figure B.2 — Example of the hydraulic circuit number 2 for on-line counter adaptation to Multi-pass test stand

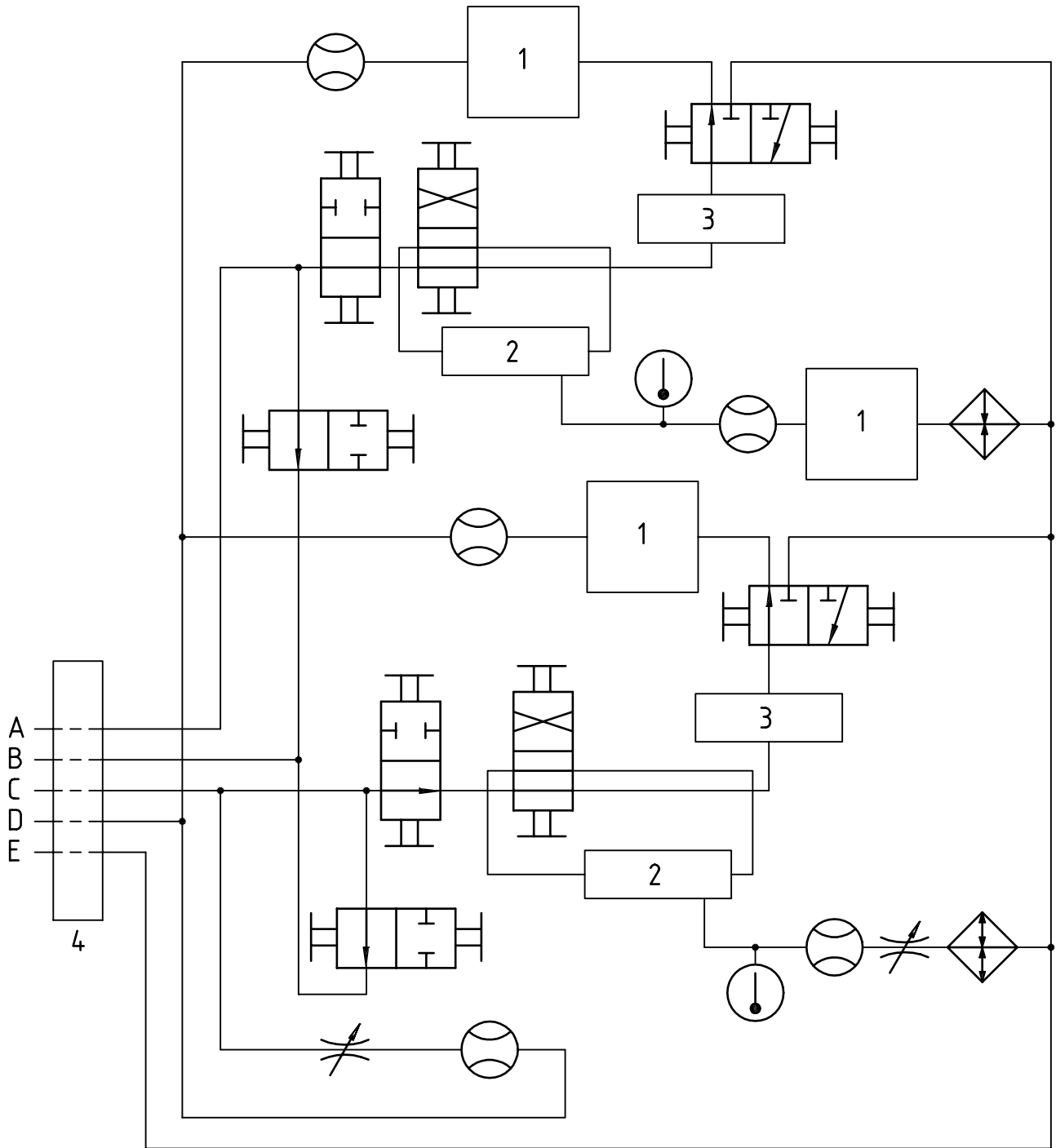

Key

- 1 Flow control
- 2 Mixer
- 3 Sensor
- 4 Test stand connection

Ports

- A Upstream sample
- B To test reservoir
- C Downstream sample
- D To pump
- E Dilution pump

Figure B.3 — Example of the hydraulic circuit number 3 for on-line counter adaptation to Multi-pass test stand

Annex C (informative)

Summary of ISO round robin study for on-line calibration and validation

The following are conclusions drawn from the on-line calibration and validation round robin study conducted for ISO/TC 131/SC 8/WG 9. Comments are given on each major step and the data and summaries are included at the end. Outliers have been excluded from the statistical results presented; however, the complete results are given in the Tables C.1 to C.8.

Each participant was supplied a set of calibration suspensions containing 2,5 mg/l of AC fine test dust (ACFTD) mixed with MIL-H-5606 hydraulic fluid in accordance with the procedures of ISO 4402³⁾. These were supplied to ensure consistency of the primary calibration. Each participating laboratory was then asked to conduct a primary calibration on their counters then follow the procedures of ISO/WD 11943 to conduct an on-line calibration and validation. The results were all sent, coded so as not to reveal the laboratory, to the National Fluid Power Association for analysis.

There were a total of 21 laboratories submitting data from the round robin study representing eight countries.

Original ACFTD calibration

Prior to recalibration with the supplied ACFTD calibration suspensions, the suspensions were counted using the laboratory's existing calibration in accordance with ISO 4402. The results, included in Table C.1, showed substantial scatter with a CV varying from 12 % to 62 % with the highest being at the 40 µm size.

Data after recalibration with ACFTD

After recalibration using the ACFTD suspensions supplied, the variations, shown in Table C.2, were much lower, generally under 10 % CV with as low as 2 % to 4 % for 1 µm to 5 µm particle sizes. The deviation of the counts after recalibration from the published ISO 4402 counts was less than 9 %

In general, the calibrations were successful.

Secondary calibration

The secondary calibrations summarized in Tables C.3 and C.4 were generally successful with 93 % of the results passing the requirements specified in 9.9 and 9.10.

Figure C.1 shows all the particle count data submitted during the secondary calibration phase of the round robin study. These data were all collected with on-line particle counting and are reported as total counts prior to dividing by the fluid volume counted or the suspension concentration. The typical standard deviation shown in Figure C.1 for the particle counts is based on the total mean counts, \bar{x} , and can be expressed as:

$$\sigma_{\text{typical}} = \sqrt{\bar{x} + 0,0004 \bar{x}^2}$$

The acceptable standard deviation for validation is based at two times the typical standard deviation as expressed above.

Particle counts for ISO MTD

The mean reference counts obtained for ISO MTD and shown in Table C.5 were extremely close to the previously reported counts (those included in column 2 of Table 3 in ISO/WD 11943). All the counts agreed with less than 5 % variation.

After exclusion of apparent outliers, 97 % of laboratories passed the requirement specified in 9.14.

3) To be cancelled and replaced by ISO 11171 (see clause 2).

On-line calibration verification

Generally the laboratories successfully passed the on-line calibration verification as shown in Table C.6. Approximately 90 % of the laboratories passed the checks for the upstream and downstream sensor calibration as well as the check on relative differences between the upstream and downstream sensors.

Based on the results of the round robin study, the final calibration limits were set to a 5 % variation in particle size together with one standard deviation of the total count.

On-line dilution validation

Only six laboratories submitted data for the on-line dilution validation which is shown in Tables C.7 and C.8. Most laboratories did not use dilution for the Multi-pass testing and therefore did not validate their dilution systems. Of those submitting data, approximately 90 % of the laboratories passed the validation requirements. If laboratory no. 2 is eliminated, 96 % to 98 % of the laboratories pass the requirements.

Generally, the dilution validation procedure appears to be successful.

Conclusions

Based upon the successful completion of each phase of the round robin study by nearly 90 % of the participating laboratories, it is concluded that the procedures contained in this International Standard are valid.

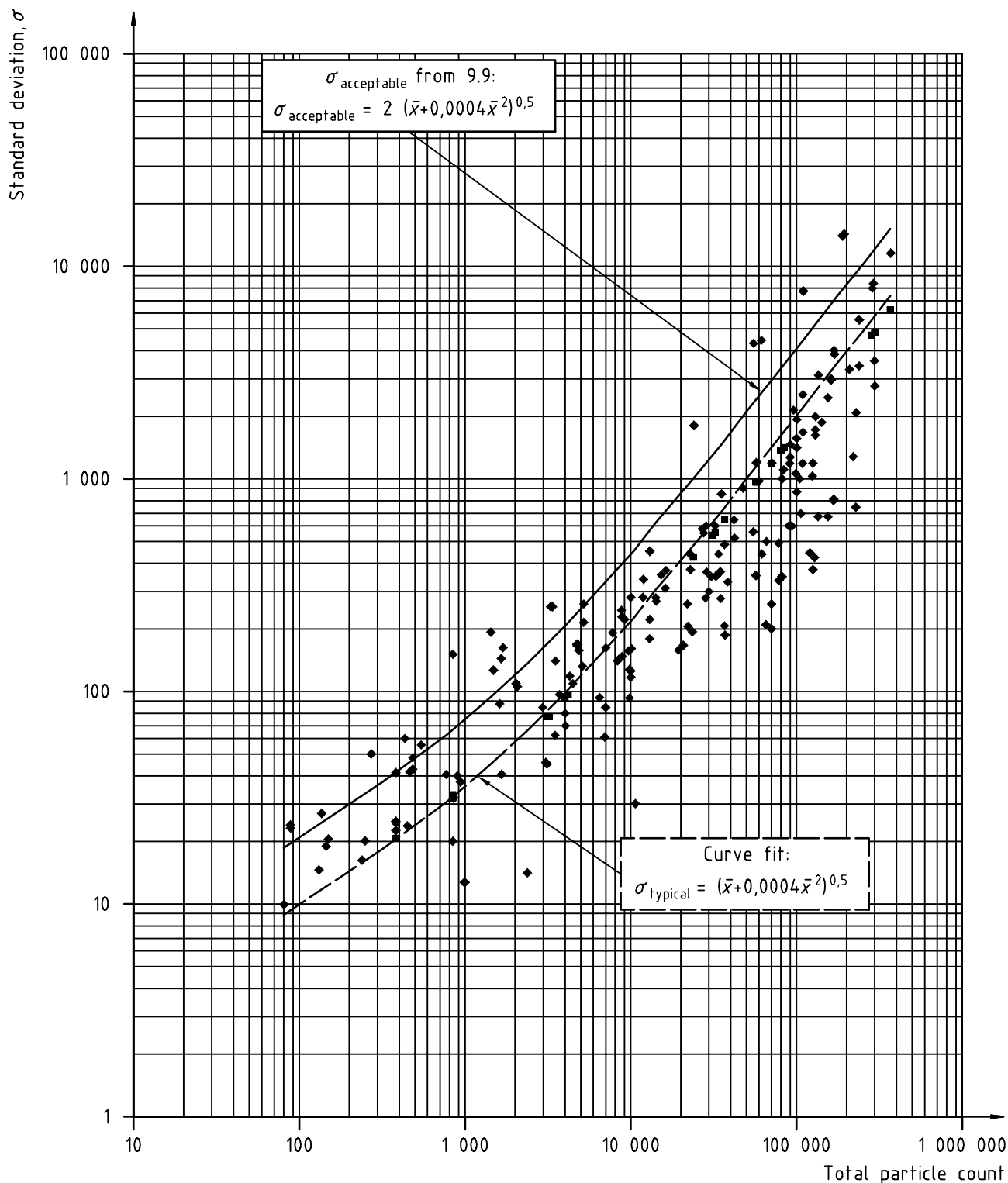

Figure C.1 — Standard deviation in relation to count from the secondary calibration

Table C.1 — Original ACFTD calibration data
Average number of particles/ml > size, μm

Lab no.	Prior to recalibration										
	1	2	3	5	7	10	12	15	20	30	40
1	4 458		2 138	987		267	174	100	47,1	14,6	
1	4 384		2 014	967		256	167	96	43,8	14,3	
2			2 346	1 207	622	304			45,8		3,1
2			2 321	1 226	612	297			45,5		2,8
3	no data										
3	no data										
4	Not performed										
5	4 270	3 250	2 360	1 271		394	247		71,0	20,0	
6		3 546	2 108	1 066	607	252		77	34,4	10,4	
6		3 298	2 048	1 020	568	238		66	33,0	9,5	
8		4 061	2 660	1 427	796	381	243	131	58,6	18,2	7,7
8		4 337	2 821	1 496	806	371	234	125	53,9	15,7	7,0
9	4 455	3 278	2 655	1 400	758	388	273	164	74,5	38,5	19,3
10				1 880	828	373	253	140	65,0	20,0	10,0
11		3 638		1 376		404		162	73,0		11,0
11		3 696		1 366		402		154	69,0		10,0
12			2 836	2 177	1 042	479	357	212	88,0	35,0	23,0
12			2 821	2 209	1 027	478	342	217	89,0	34,0	20,7
13		4 730		1 808		491		189	93,7		11,1
13	5 839	4 698	3 307	1 688	946	444	329	198	95,9	21,4	7,0
14		3 121	2 025	1 075		308		99	36,9	5,1	
15	4 973	2 914		1 103		280		103	63,3		
15	4 170	2 785		1 008		265		92	46,5		
16		3 899	2 932	1 875		670		283	137,3	22,4	4,3
19	4 764	3 665	2 469	1 267	747	370	248	138	56,8	15,0	5,5
22		3 866	2 597	1 356		369		131	59,7	18,5	7,2
22		3 789	2 535	1 313		354		124	56,7	17,2	6,9
24			3 078	1 234	696	299				16,5	
24			3 267	1 236	648	316				15,2	
26			2 935	1 391		355		214	58,3		4,9
26			2 575	1 397		382		141	64,9		5,6
27		4 145	2 492	1 094		280			57,0		8,0
27		3 930	2 406	1 098		299			59,0		8,0
28		4 409	2 970	1 425	765	357	229	129	55,4	14,6	5,1
28		4 238	2 863	1 398	763,2	357,5	228,3	128,7	55,7	14,9	5,5
Mean	4 664	3 776	2 599	1 370	764	359	256	145	63,0	18,6	8,8
CV	12 %	14 %	14 %	24 %	19 %	25 %	23 %	35 %	34 %	44 %	62 %

Table C.2 — Data after recalibration with ACFTD

Lab. no.	After recalibration										% Deviation from ISO 4402											
	1	2	3	5	7	10	12	15	20	30	40	1	2	3	5	7	10	12	15	20	30	40
4 380	3 492	2 480	1 292	735	360	238	138	63,7	18,8	7,2												
1	4 351		2 332	1 282		350	241	140	64,6	20,5												
1	4 329		2 388	1 287		353	247	146	62,1	20,2												
2			2 417	1 252	653	291			43,6	3,8												
2			2 402	1 287	637	279			41,2	3,3												
3	4 963	3 308	2 409	1 220	695	314		137	92,0	18,7	11,9											
3	4 910	3 209	2 363	1 295	721	344		156	71,5	21,5	8,9											
4	not performed																					
5	not performed																					
6		3 606	2 298	1 267	790	385		143	66,5	20,2												
6		3 640	2 333	1 233	765	410		158	68,8	19,8												
8		3 540	2 439	1 334	722	349	234	133	61,6	19,1	7,6											
8		3 554	2 490	1 314	728	354	241	139	62,7	18,9	7,4											
9	4 438	3 483	2 283	1 215	663	333	235	131	66,3	18,8	7,3											
10				2 193	818	368	243	128	65,0	20,0	10,0											
11		3 434		1 240		362		143	69,0		9,0											
11		3 467		1 245		356		144	67,0		9,0											
12			2 569	1 248	687	326	190	108	54,2	16,3	5,9											
12			2 573	1 341	706	373	217	115	58,6	19,9	5,8											
13		3 485		1 367		358		142	67,7		9,7											
13		3 357	2 387	1 214		317		121		16,7												
14		3 466	2 458	1 226		348		133	58,8	18,0												
15	4 686	3 593		1 317		374		147	66,4													
15	4 318	3 425		1 294		362		149	69,9													
16		4 085	2 933	1 861		515		188	86,9	23,9	8,5											
19	4 216	3 491							58,5	18,8	8,0											
22		3 509	2 520	1 310		362		137	63,1	18,8	7,0											
22		3 518	2 490	1 314		359		139	63,5	18,1	7,1											
24			2 313	1 185	769	349				17,5												
24			2 528	1 305	769	389				17,8												
26			2 473	1 297		365		138	64,0		7,3											
26			2 483	1 278		367		138	63,5		7,3											
27		3 575	2 415	1 275		356			62,0		8,0											
27		3 546	2 480	1 301		359			63,0		8,0											
28		3 427	2 390	1 245	732	368	245	145	66,6	18,7	7,2											
28		3 405	2 385	1 247	723	362	244	141	63,9	17,9	7,2											
All data																						
Mean	4 526	3 506	2 444	1 321	723	358	234	140	64,4	19,1	7,6											
CV	6 %	5 %	5 %	5 %	7 %	11 %	8 %	11 %	15 %	9 %	24 %											
without labs 2, 3, 10, 12, 16																						
Mean	4 390	3 501	2 415	1 275	740	360	241	140	64,5	18,7	7,8											
CV	4 %	2 %	3 %	3 %	5 %	5 %	2 %	5 %	5 %	6 %	11 %											

*** Indicates labs which have several % deviations > 10 % from ISO 4402, some of which appear to be due to sizes reported being offset.

Table C.3 — Secondary calibration data — Mean counts
Particle counts > size, μm

Lab. no.	Conc. mg/l	Count vol. ml	Mean particle counts										
			1	2	3	5	7	10	12	15	20	30	40
1	4,4	1	211 154		139 143	79 244		21 583	13 222	7 025	3 026	767	
1	4,8	1	231 201		156 004	90 530		24 499	15 809	8 762	3 593	890	
2	20	10			188 650	109 060	61 540	23 980			3 440		260
2	20	10			186 490	107 640	58 060	23 370			3 250		260
4	4,6	26			161 200	91 390		27 794		8 424	3 455	874	
4	4,6	26			157 678	92 167		28 695		8 655	3 544	893	
5	3	25	158 347	130 422	99 013	57 998	32 765	14 229	9 119	4 777	1 926	465	144
5	3	25	157 133	129 123	98 581	57 629	32 553	14 179	8 938	4 713	1 981	492	150
6	1,9	25		101 897	71 334	41 562	25 942	12 873		4 212	1 640	381	
8	7	25		298 909	227 410	134 612	81 596	37 375	22 717	12 050	5 310	1 456	
8	7	25		293 026	222 098	131 358	79 947	36 805	22 433	11 749	5 160	1 389	
9	3	25	138 160		97 405	57 210	34 673	16 235		5 274			
10	5	25				104 626		31 043		9 934	4 057	828	236
10	5	25				106 810		31 527		9 730	4 237	828	250
11	3	50		239 556		108 866		32 874		10 083	4 039		380
11	3	50		234 257		110 741		33 107		9 846	4 398		386
12	3	1			90 975	55 175		15 450		4 900	2 000	550	138
13	2,5	25	122 625		77 675		27 825	13 025			1 618		90
13	2,5	25	124 550		79 025		28 350	13 188			1 700		93
14	3	25		132 027	100 966	58 829	32 816	15 577	9 934				
15	2,5	25	99 628	82 816		36 026		9 732		3 624	1 589		
19	1	50	100 099	82 720	65 688	39 115	23 891	10 920	6 552	3 561	1 472	383	128
22	5	20		155 152	121 728	69 948		19 452		6 984	3 142	824	
22	5	20		154 752	120 206	70 098		19 294		7 214	3 184	856	
24	2	25			63 506	36 819	21 571	10 251				442	
24	2	25			63 354	36 187	21 161	10 008				459	
26	3,5	10			45 726	27 183		7 715		2 377	1 004		82
27	5	50		373 879	286 023	171 915		43 718			4 700		474
27	5	50		369 936	288 110	167 360		42 828			4 676		419

Table C.5 — Particle counts for ISO MTD

Lab. no.	Reference particle counts for ISO MTD, particles/ml > size, µm										Pass (1) or fail (0) (1,3 × column 4 limits)											
	1	2	3	5	7	10	12	15	20	30	40	1	2	3	5	7	10	12	15	20	30	40
Limits >	2 000	1 660	1 300	757	450	215	126	69,6	28,7	7,3	2,3	90	85	80	69	52	35	19	12	5,5	2	0,7
1	1 944		1 281	729		199	122	64,7	27,9	7,1				1	1		1	1	1	1	1	
1	1 928		1 301	755		204	132	73,1	30,0	7,4				1	1		1	1	1	1	1	
2			943	545	308	120		17,2		1,3				0	0	0	0			0		0
2			932	538	290	117		16,3		1,3				0	0	0	0			0		0
3		1 816	1 033	506	270	127		61,4	33,5	10,5	4,5		0	0	0	0	0	0	1	1	0	0
4			1 343	761		231		70,2	29,7	7,3				1	1		1	1	1	1	1	
4			1 314	768		238		72,1	29,5	7,4				1	1		1	1	1	1	1	
5	2 110	1 739	1 320	773	437	190	122	63,7	25,7	6,2	1,9	1	1	1	1	1	1	1	1	1	1	1
5	2 095	1 722	1 314	768	434	189	119	62,8	26,4	6,6	2,0	1	1	1	1	1	1	1	1	1	1	1
6		2 101	1 471	857	535	265		87,0	34,0	7,8			0	0	0	0	0		0	1	1	
8		1 707	1 299	769	466	214	130	69,9	30,3	8,3			1	1	1	1	1	1	1	1	1	
8		1 674	1 269	751	457	210	128	67,1	29,5	7,8			1	1	1	1	1	1	1	1	1	
9	1 842		1 299	763	462	217		70,3				0		1	1	1	1	1	1	1	1	
10				805		240		75,0	33,0	7,2	2,4			1	1		1	1	1	1	1	1
10				796		239		77,0	32,0	7,3	2,3			1	1		1	1	1	1	1	1
11		1 562		738		221		65,6	29,3	2,6			1		1		1	1	1	1	1	1
11		1 597		726		219		67,2	26,9	2,5			1		1		1	1	1	1	1	1
12			1 383	817	439	231	139	71,0	33,0	8,5	2,4			1	1	1	1	1	1	1	1	1
13	2 037		1 354		466		116		24,8	5,1		1		1		1		1	1	1	1	
13	2 027		1 334		467		116		23,9	5,1		1		1		1		1	1	1	1	
14			1 760	1 346	784	438	208	132					1	1	1	1	1	1	1	1	1	
15	1 594	1 325		576		156		58,0	25,4			0	0		0		0		1	1	1	
16		1 751	1 406	782		261		72,4	25,2	5,3	1,9	1	1	0	1		0		1	1	1	1
19	2 002	1 654	1 314	782	478	218	131	71,2	29,4	7,7	2,6	1	1	1	1	1	1	1	1	1	1	1
22		1 552	1 217	700		195		69,8	31,4	8,2			1	1	1	1	1	1	1	1	1	
22		1 547	1 202	701		193		72,1	31,9	8,5			0	1	1	1	1	1	1	1	1	
24			1 270	736	431	205				8,8				1	1	1	1	1	1	1	1	
24			1 267	724	423	200				9,2				1	1	1	1	1	1	1	1	
26			1 306	777		220		67,9	28,7					1	1	1	1	1	1	1	1	
27		1 632	1 247	700		200				2,5			1	1	1	1	1	1	1	1	1	1
28		1 317	960	566	294	193	118	62,0	31,0	12,7	3,6		0	0	0	0	1	1	1	1	0	0
28		1 255	897	550	305	184	118	61,0	28,0	9,8	3,0		0	0	0	0	1	1	1	1	0	1
(with all labs included)																						
Mean	1 953	1 630	1 245	718	411	203	125	69	28	7,8	2,4											
CV	8 %	13 %	12 %	13 %	19 %	18 %	6 %	9 %	15 %	22 %	32 %											
(with labs 2, 3, 6, 15 and 28 removed)																						
Mean	1 998	1 658	1 304	757	450	215	126	70	29	7,3	2,3											
CV	4 %	5 %	4 %	4 %	4 %	9 %	6 %	5 %	10 %	17 %	11 %											
Number of labs passing excluding labs 2, 3, 6, 15 and 28 >																						
Number of labs failing >																						
Total number of labs/counters >																						
% of labs passing >																						
												7	11	20	23	12	22	11	19	21	18	10
												1	1	1	0	0	1	0	0	0	0	0
												8	12	21	23	12	23	11	19	21	18	10
												88	92	95	100	100	96	100	100	100	100	100

shift in data?

shift in data?

Table C.6 — On-line calibration verification
Average number of particles/μg > size, μm

Lab. no.	Average particles/μg > size, μm														Upstream		Downstream		Up vs. down										
	Upstream sensor							Downstream sensor							% pass	% fail	% pass	% fail	% pass	% fail									
	1	2	3	5	7	10	12	15	20	30	40	1	2	3	5	7	10	12	15	20	30	40	% pass	% fail	% pass	% fail	% pass	% fail	
1	1 953		1 343	767		203	124	64														100	0	100	0	100	0		
2			859	496	278	109		16		1,5												83	17	83	17	100	0		
4			1 352	763		225		68	27	6,8												100	0	100	0	100	0		
5	2 048	1 694	1 294	766	436	192	125	66	27	7,1	2,1											100	0	100	0	100	0		
6		1 608	1 142	675	429	221		79	33	8,7												38	63	25	75	63	38		
8		1 684	1 287	769	479	220	134	70	31	8,4												100	0	100	0	100	0		
9	1 954		1 249	735	431	204		65														83	17	100	0	83	17		
10				756		224		73	32	6,0	2,0											100	0	86	14	57	43		
11		1 663	1 267	768	478	227	137															67	33	67	33	100	0		
12			1 207	734		209			27	7,8	2,1											50	50	67	33	83	17		
13	1 878		1 254	721	439	191	110															50	50	100	0	50	50		
14		1 743	1 333	776	432	205	130															100	0	100	0	83	17		
15	1 544	1 285		564		153		58	25													100	0	100	0	50	50		
19	1 982	1 632	1 302	758	465	217	132	71	29	7,8	2,5											100	0	100	0	100	0		
19	2 005	1 659	1 260	749	429	198	130	72	27	6,9	2,2											100	0	100	0	100	0		
22		1 547		699		192		71	31	8,2												100	0	100	0	100	0		
24			1 257	743	435	210				8,6												100	0	100	0	100	0		
26			1 261	733		220		68	33		2,4											100	0	100	0	100	0		
27		1 638	1 257	690		197		31		3,2												83	17	67	33	83	17		
(with all labs included)																													
Mean	1 909	1 615	1 245	719	430	201	128	69	28	8	2											203	130	70	29	7	2		
CV %	9	8	9	10	13	14	7	8	15	12	22											14	6	6	16	22	22		
(with lab. 2 removed)																													
Mean	1 909	1 615	1 271	731	445	206	128	69	29	8	2											209	130	70	30	7	2		
CV %	9	8	4	7	5	9	7	8	9	12	18											7	6	6	10	22	14		
																								% of total labs >					
																								89	11	90	10	88	12

ICS 23.100.60

Price based on 30 pages
