**Road vehicles — Controller area network
(CAN) —**

Part 5:
**High-speed medium access unit
with low-power mode**

*Véhicules routiers — Gestionnaire de réseau de communication
(CAN) —*

*Partie 5: Unité d'accès au médium haute vitesse avec mode
de puissance réduite*



PDF disclaimer

This PDF file may contain embedded typefaces. In accordance with Adobe's licensing policy, this file may be printed or viewed but shall not be edited unless the typefaces which are embedded are licensed to and installed on the computer performing the editing. In downloading this file, parties accept therein the responsibility of not infringing Adobe's licensing policy. The ISO Central Secretariat accepts no liability in this area.

Adobe is a trademark of Adobe Systems Incorporated.

Details of the software products used to create this PDF file can be found in the General Info relative to the file; the PDF-creation parameters were optimized for printing. Every care has been taken to ensure that the file is suitable for use by ISO member bodies. In the unlikely event that a problem relating to it is found, please inform the Central Secretariat at the address given below.



COPYRIGHT PROTECTED DOCUMENT

© ISO 2007

All rights reserved. Unless otherwise specified, no part of this publication may be reproduced or utilized in any form or by any means, electronic or mechanical, including photocopying and microfilm, without permission in writing from either ISO at the address below or ISO's member body in the country of the requester.

ISO copyright office
Case postale 56 • CH-1211 Geneva 20
Tel. + 41 22 749 01 11
Fax + 41 22 749 09 47
E-mail copyright@iso.org
Web www.iso.org

Published in Switzerland

Contents

Page

Foreword.....	iv
Introduction	v
1 Scope	1
2 Normative references	1
3 Terms and definitions	1
4 Symbols and abbreviated terms	2
5 Functional description of medium access unit (MAU) with low-power mode	2
5.1 General	2
5.2 Physical medium attachment sub layer specification	2
6 Conformance tests	5
6.1 General	5
6.2 V_{Split} output function	5
6.3 Output voltage during low-power mode	6
6.4 Internal resistance during low-power mode	6
6.5 Propagation delay during normal mode	7
6.6 Wake-up filter time during low-power mode	7
6.7 Bus driver symmetry during normal mode	7
6.8 Input leakage current, unpowered device	8
7 Electrical specification of high-speed medium access unit (HS-MAU)	8
7.1 Physical medium attachment sub layer specification	8
7.2 CAN node	10
7.3 Medium dependent interface (MDI) specification, connector parameters	18
7.4 Physical medium specification	18
Bibliography	20

Foreword

ISO (the International Organization for Standardization) is a worldwide federation of national standards bodies (ISO member bodies). The work of preparing International Standards is normally carried out through ISO technical committees. Each member body interested in a subject for which a technical committee has been established has the right to be represented on that committee. International organizations, governmental and non-governmental, in liaison with ISO, also take part in the work. ISO collaborates closely with the International Electrotechnical Commission (IEC) on all matters of electrotechnical standardization.

International Standards are drafted in accordance with the rules given in the ISO/IEC Directives, Part 2.

The main task of technical committees is to prepare International Standards. Draft International Standards adopted by the technical committees are circulated to the member bodies for voting. Publication as an International Standard requires approval by at least 75 % of the member bodies casting a vote.

Attention is drawn to the possibility that some of the elements of this document may be the subject of patent rights. ISO shall not be held responsible for identifying any or all such patent rights.

ISO 11898-5 was prepared by Technical Committee ISO/TC 22, *Road vehicles*, Subcommittee SC 3, *Electrical and electronic equipment*.

ISO 11898 consists of the following parts, under the general title *Road vehicles — Controller area network (CAN)*:

- *Part 1: Data link layer and physical signalling*
- *Part 2: High-speed medium access unit*
- *Part 3: Low-speed, fault-tolerant, medium-dependent interface*
- *Part 4: Time-triggered communication*
- *Part 5: High-speed medium access unit with low-power mode*

Introduction

ISO 11898 was first published as one document in 1993. It covered the CAN data link layer as well as the high-speed physical layer.

In the reviewed and restructured ISO 11898 series:

- Part 1 describes the data link layer including the logical link control (LLC) sub layer and the medium access control (MAC) sub layer as well as the physical signalling (PLS) sub layer;
- Part 2 defines the high-speed medium access unit (MAU);
- Part 3 defines the low-speed fault-tolerant medium access unit (MAU);
- Part 4 defines the time-triggered communication;
- Part 5 defines the power modes of the high-speed medium access unit (MAU).

ISO 11898-1 and ISO 11898-2 have been cancelled and replaced ISO 11898:1993.

Road vehicles — Controller area network (CAN) —

Part 5: High-speed medium access unit with low-power mode

1 Scope

This part of ISO 11898 specifies the CAN physical layer for transmission rates up to 1 Mbit/s for use within road vehicles. It describes the medium access unit functions as well as some medium dependent interface features according to ISO/IEC 8802-2.

This part of ISO 11898 represents an extension of ISO 11898-2, dealing with new functionality for systems requiring low-power consumption features while there is no active bus communication.

Physical layer implementations according to this part of ISO 11898 are compliant with all parameters of ISO 11898-2, but are defined differently within this part of ISO 11898. Implementations according to this part of ISO 11898 and ISO 11898-2 are interoperable and can be used at the same time within one network.

2 Normative references

The following referenced documents are indispensable for the application of this document. For dated references, only the edition cited applies. For undated references, the latest edition of the referenced document (including any amendments) applies.

ISO 7637-3, *Road vehicles — Electrical disturbances from conduction and coupling — Part 3: Electrical transient transmission by capacitive and inductive coupling via lines other than supply lines*

ISO 11898-2:2003, *Road vehicles — Controller area network (CAN) — Part 2: High-speed medium access unit*

3 Terms and definitions

For the purposes of this document, the terms and definitions given in ISO 11898-2 and the following apply.

3.1

VCC

⟨CAN node⟩ supply voltage of the physical layer used for the bus receiver, transmitter and optional split termination voltage V_{Split} during normal mode

NOTE Typical voltage of VCC is 5 V.

3.2

split termination voltage

V_{Split}

⟨CAN node⟩ output voltage of split termination support output relative to ground signal of the module (GND)

3.3 propagation time

t_{Prop}
 (CAN node) signal propagation time measured from an edge at transmit data (TXD) input to the corresponding edge on receive data (RXD) output of the MAU

3.4 wake-up filter time

t_{Wake}
 (CAN node) duration of a dominant signal on the bus lines CAN_H and CAN_L for forcing a wake-up to the CAN NODE

3.5 wake-up pattern

(CAN node) one or multiple consecutive dominant bus levels for at least t_{Wake} , each separated by a recessive bus level

NOTE Figures within this part of ISO 11898 are using arrows as following: voltages + → -; currents flowing from the positive to the negative pole.

4 Symbols and abbreviated terms

For the purposes of this document, the symbols and abbreviated terms given in ISO 11898-2 apply.

5 Functional description of medium access unit (MAU) with low-power mode

5.1 General

The following description is valid for a two-wire differential bus. The values of the voltage levels, the resistances and the capacitances as well as the termination network are described in Clause 7.

5.2 Physical medium attachment sub layer specification

5.2.1 General

As shown in Figure 1 the bus line is terminated by termination network A and termination network B. These terminations are intended to suppress reflections.

Besides this reflection-optimized termination structure, centralized single terminations are possible at limited bit rates and topologies.

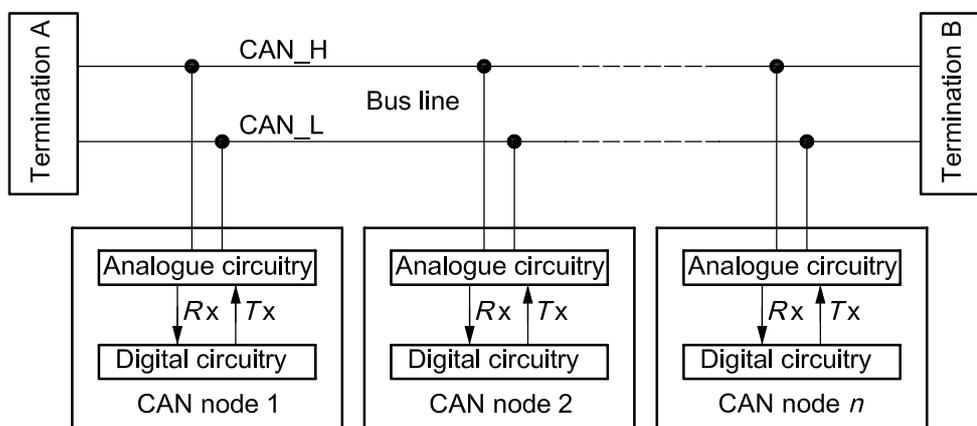
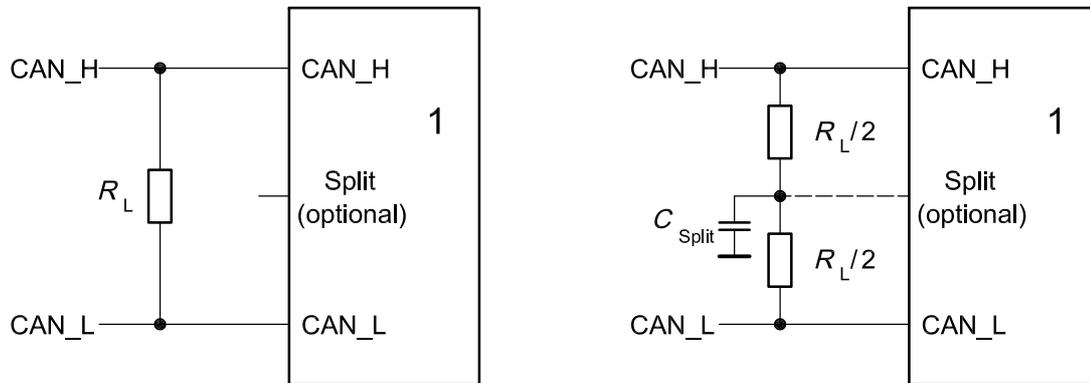

Figure 1 — Suggested electrical interconnection

Two different termination models are recommended within the high-speed medium access unit according to Figures 1 and 2:

- termination with a single resistor between CAN_H and CAN_L, and
- split termination dividing the single resistor into two resistors with the same value in series connection, while the centre tap is connected to a grounding capacitor and optionally to a dedicated split supply.



Key

1 physical layer

Figure 2 — Termination variants, single resistor termination and split termination

In order to support low-power functionality, two different modes of operation are defined as follows.

- Normal mode: The behaviour during normal mode is described within ISO 11898-2.
- Low-power mode: Described within this part of ISO 11898.

5.2.2 Bus levels during normal mode

The bus can have one of the two logical states: recessive or dominant (see Figure 3).

The bus is in the recessive state if the bus drivers of all CAN nodes are switched off. In this case, the mean bus voltage is generated by the termination and by the high internal resistance of each CAN node's receiving circuitry. In the recessive state, V_{CAN_H} and V_{CAN_L} are fixed to a mean voltage level, determined by the bus termination. V_{diff} is less than a maximum threshold. The recessive state is transmitted during bus idle or a recessive bit. Figure 3 illustrates the maximum allowed differential recessive bus voltage. Typically, the differential voltage is about zero volts.

Optionally the recessive bus state may become stabilized making use of a dedicated split termination voltage (V_{Split}). This optional output voltage of physical layer implementations according to this part of ISO 11898 may be optionally connected to the centre tap of the split termination resistors. Whenever the receiver of a physical layer is not actively biasing towards 2,5 V, the optional V_{Split} shall become floating.

A dominant bit is sent to the bus if the bus driver of at least one unit is switched on. This induces a current flow through the terminating resistors, and consequently a differential voltage between the two wires of the bus. A differential voltage greater than a minimum threshold represents the dominant state. The dominant state overwrites the recessive state, and is transmitted during a dominant bit.

The dominant and recessive states are detected by transforming the differential voltages of the bus to the corresponding recessive and dominant voltage levels within the receive comparator.

During arbitration, various CAN nodes may simultaneously transmit a dominant bit. In this case, V_{diff} exceeds the V_{diff} seen during a single operation. Single operations means that the bus is driven by one CAN node only.

5.2.3 Bus levels during low-power mode

During low-power mode, the bus drivers are entirely disabled. It is not possible to actively drive a differential level to the bus lines using a physical layer within low-power mode. In contrast to the normal mode behaviour, the bus wires shall be pulled to the ground signal of the module (GND) via the high-ohmic internal input resistors R_{in} of the receiver. Thus, there is no active VCC supply required defining the bus levels during low-power operation.

The optional split termination voltage (V_{Split}) is disabled here and shall behave high-ohmic (floating) in order not to pull the bus into a certain direction.

From a physical point of view, there are only the two defined operating conditions possible. The normal mode with $VCC/2$ biasing whenever normal bus communication takes place and low-power mode with GND biasing whenever the system becomes shutdown.

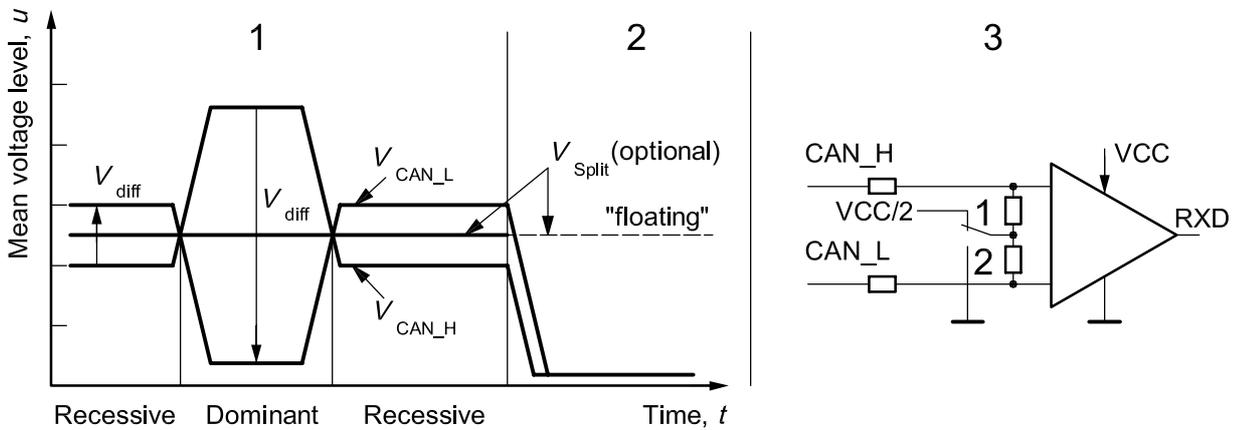

Key

- 1 normal mode
- 2 low-power mode
- 3 simplified transceiver bias implementation

Figure 3 — Physical bit representation and simplified bias implementation

5.2.4 Wake-up out of low-power mode

During low-power operation, a physical layer optionally shall monitor the bus lines CAN_H and CAN_L for wake-up events. Implementations supporting this feature shall make use of a differential bus comparator monitoring the bus line. A bus wake-up shall be performed if the bus shows one or multiple consecutive dominant bus levels for at least t_{Wake} , each separated by a recessive bus level.

5.2.5 Systems with unpowered nodes

In order to allow undisturbed CAN communication in systems, which have a couple of nodes intentionally unpowered (e.g. ignition key controlled modules), while other nodes continue to communicate normally, it is important that these unpowered nodes affect the bus levels as little as possible. This requires that transceivers, which are temporarily unpowered, show a lowest possible leakage current to the bus lines inside the still communicating system. The lower the leakage current in the unpowered case, the better the system performance in the permanently supplied part of the network.

Depending on the target application (permanently supplied or temporarily unsupplied) the maximum leakage parameter according to Table 4 can be tolerated (permanently supplied nodes) or should be reduced as far as possible (temporarily unsupplied nodes).

NOTE In contrast to a low-power mode, where the device is still supplied, unpowered means a physical disconnection from the power supply.

6 Conformance tests

6.1 General

All conformance tests for normal mode of operation are specified in ISO 11898-2. Besides these tests, some tests are added dealing with the optional V_{Split} functionality and the low-power mode behaviour.

The figures and the formulae shown within this clause indicate the principles of how the electrical parameters specified in Clause 7 should be verified.

6.2 V_{Split} output function

6.2.1 General

V_{Split} is an optional output voltage supporting recessive bus stabilization. When this function is implemented, the behaviour of that output shall be measured as shown within the following clauses.

6.2.2 V_{Split} during normal mode

The optional output V_{Split} delivers an output voltage of $V_{CC}/2$ during normal mode.

According to Table 6, an output current of $+500 \mu\text{A}$ to GND (Figure 4 schematic A) and $-500 \mu\text{A}$ to VCC (Figure 4 schematic B) shall be adjusted with the resistor R , while the output voltage V_{Split} shall stay within the limits.

In unloaded condition (Figure 4 schematic C), the output voltage shall be checked according to Table 6 using a load resistance of $\geq 1 \text{ M}\Omega$.

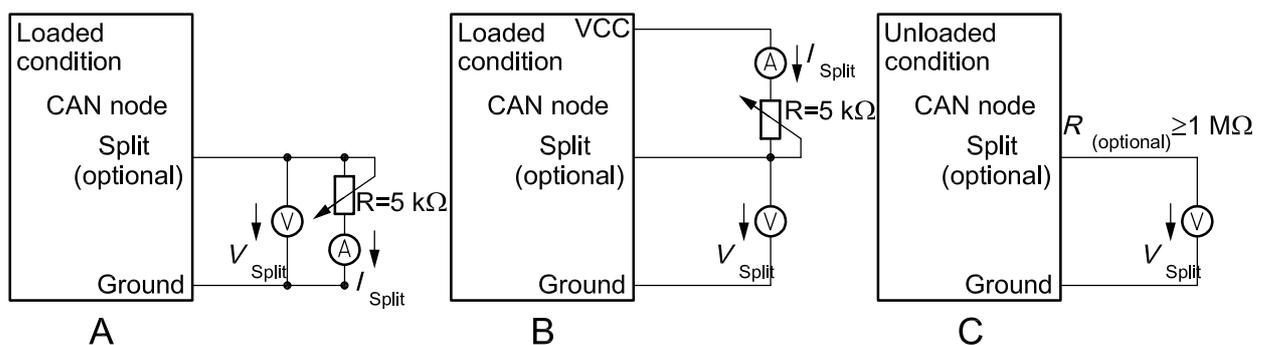

Figure 4 — Measurement of V_{Split} during normal mode

6.2.3 V_{Split} during low-power mode

The optional output V_{Split} shall float during low-power mode (see Figure 5). The leakage current is defined in Table 6.

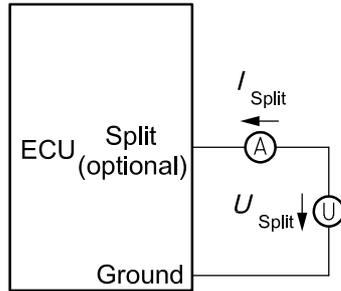

Figure 5 — Measurement of leakage current I_{Split} during low-power mode

6.3 Output voltage during low-power mode

During low-power mode, CAN_H and CAN_L shall be pulled towards GND using the internal input resistor R_{in} of the bus receiver network (see Figure 6). Voltage levels at CAN_H and CAN_L shall be in accordance with Table 8.

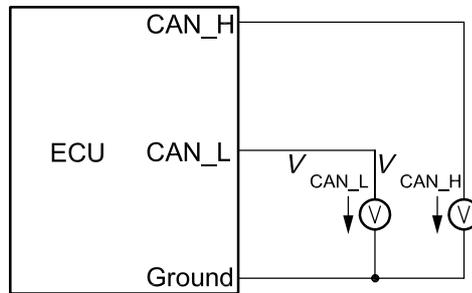

Figure 6 — Measurement of V_{CAN_L} and V_{CAN_H} during low-power mode

6.4 Internal resistance during low-power mode

During low-power mode, CAN_H and CAN_L shall be pulled towards GND with the internal input resistor network (see Figure 7), according to Table 9.

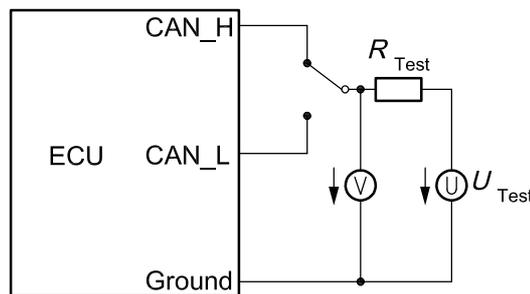

Figure 7 — Measurement of R_{in} during low-power mode

Applying a voltage U_{Test} to the test circuit allows the calculation of R_{in} based on the voltage divider defined with R_{Test} as follows:

$$R_{in_L,H} = \frac{R_{Test} \times V}{U_{Test} - V}$$

6.5 Propagation delay during normal mode

In case of access to the pins RXD [Receive Data (serialized data)] and TXD [Transmit Data (serialized data)] of a physical layer implementation, the signal propagation time shall be measured according to Figure 8. Table 11 specifies the propagation time and defines values for R_L , C_L , f_{TXD} and C_{RXD} .

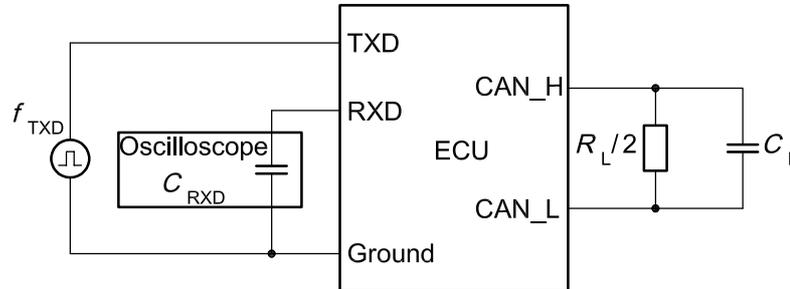

Figure 8 — Measurement of t_{Prop} during normal mode

6.6 Wake-up filter time during low-power mode

In order to suppress unwanted wake-up events within physical layers supporting a remote bus wake-up feature, a certain dominant filter time shall be implemented (see Figure 9).

The device under test shall not signal a wake-up condition with dominant pulses shorter than $t_{Wake(min)}$ and shall signal a wake-up condition with dominant pulses longer than $t_{Wake(max)}$ according to Table 11. Dominant pulses with a length between $t_{Wake(min)}$ and $t_{Wake(max)}$ may lead to a wake-up depending on filter spread. According to the target bit rate of the system, the individual time thresholds of an implementation can be adapted, but shall stay within the defined minimum and maximum timings as defined in Table 11.

The test shall be performed within the full common mode voltage range as specified in Table 3.

R_L , U_{CM} , t_{Pulse} and I values are defined in Table 11.

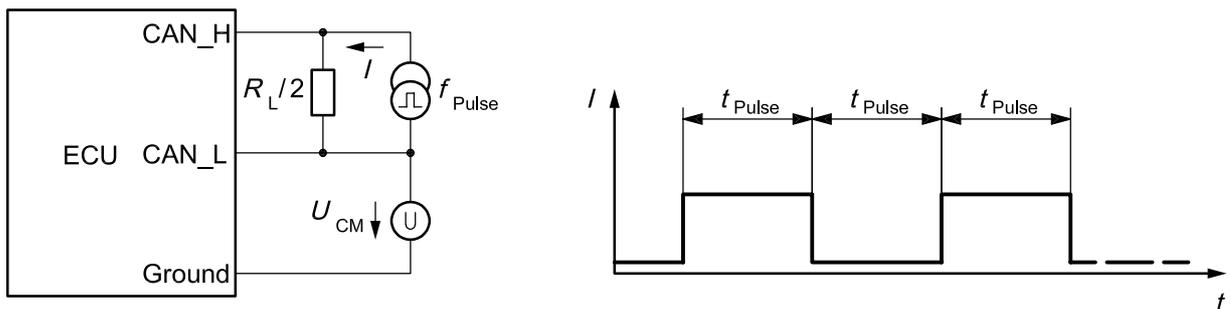

Figure 9 — Measurement of the wake-up filter time during low-power mode

6.7 Bus driver symmetry during normal mode

Due to electromagnetic compatibility (EMC) reasons, the CAN_H and CAN_L driver stage must behave symmetrically, especially during the bit transitions from recessive to dominant and dominant to recessive. An oscilloscope is used to verify that the so-called common mode bus voltage stays within the limits during the recessive bit time, the dominant bit time and the bit transition times, according to Table 5. (See Figure 10.)

R_L , f_{TXD} and C_{Split} values are defined in Table 5, and $V_{SYM} = V_{CAN_H} + V_{CAN_L}$

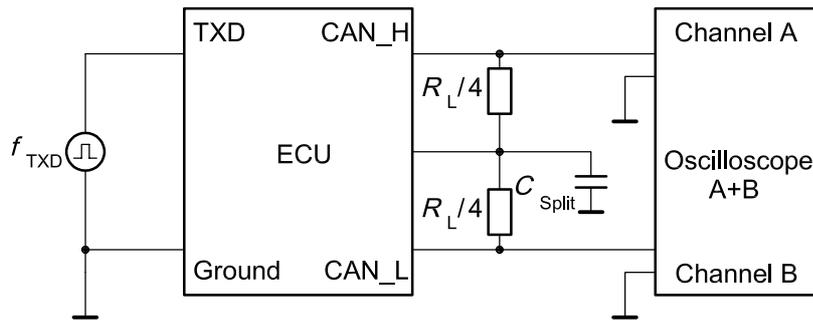

Figure 10 — Measurement of bus driver symmetry V_{SYM}

6.8 Input leakage current, unpowered device

An unpowered device shall not disturb the communication of the residual network. The required maximum leakage currents I_{CAN_H} and I_{CAN_L} as well as U_{BUS} and U_{Supply} are defined in Table 4. (See Figure 11.)

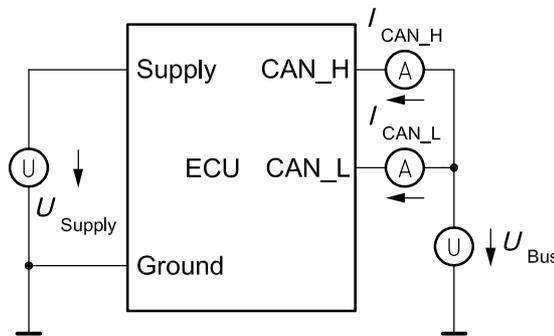

Figure 11 — Measurement of input leakage current of an unpowered device

7 Electrical specification of high-speed medium access unit (HS-MAU)

7.1 Physical medium attachment sub layer specification

7.1.1 General

All data given in Tables 1 to 10 are independent of a specific physical layer implementation. The parameters specified in these tables shall be fulfilled throughout the operating temperature range as specified for every individual CAN node.

7.1.2 Bus levels

7.1.2.1 Common mode voltages

The parameters specified in Tables 1 to 6 apply when all CAN nodes are connected to a correctly terminated bus.

7.1.2.2 Disturbance by coupling

The tolerated disturbances of CAN_H and CAN_L by coupling are defined in accordance with ISO 7637-3, test pulses 3a and 3b.

7.1.3 Optional split output level

The optional split out put level is indicated in Table 6.

Table 1 — Bus voltage parameters for reception of recessive state, normal mode

Parameter	Notation	Unit	Value			Condition
			min.	nom.	max.	
Common mode bus voltage	V_{CAN_H}	V	—	2,5	12,0	Measured with respect to the individual ground of each CAN node
	V_{CAN_L}	V	-12,0	2,5	—	
Differential bus voltage ^a	V_{diff}	mV	-120	0	12	Measured at each CAN node connected to the bus

^a The differential bus voltage is determined by the output behaviour of all CAN nodes during the recessive state. Therefore, V_{diff} is approximately zero (see Table 8). The minimum value is determined by the requirement that a single bus driver shall be able to represent a dominant bit by a minimum value of $V_{diff} = 1,2$ V.

Table 2 — Bus voltage parameters for reception of dominant state, normal mode

Parameter	Notation	Unit	Value			Condition
			min.	nom.	max.	
Common mode bus voltage ^a	V_{CAN_H}	V	—	3,5	12,0	Measured with respect to the individual ground of each CAN node
	V_{CAN_L}	V	-12,0	1,5	—	
Differential bus voltage ^b	V_{diff}	V	1,2	2,0	3,0	Measured at each CAN node connected to the bus

^a The minimum value of V_{CAN_H} is determined by the minimum value of V_{CAN_L} plus the minimum value of V_{diff} . The maximum value of V_{CAN_L} is determined by the maximum value of V_{CAN_H} minus the minimum value of V_{diff} .

^b The bus load increases as CAN nodes are added to the network, by R_{diff} . Consequently, V_{diff} decreases. The minimum value of V_{diff} determines the number of CAN nodes allowed on the bus. The maximum value of V_{diff} is specified by the upper limit during arbitration.

Table 3 — Bus voltage parameters for low-power mode

Parameter	Notation	Unit	Value			Condition
			min.	nom.	max.	
Common mode bus voltage	V_{CAN_H}	V	—	0	12,0	Measured with respect to the individual ground of each CAN node
	V_{CAN_L}	V	-12,0	0	—	
Differential bus voltage ^a	V_{diff}	mV	-120	0	12	Measured at each CAN node connected to the bus

^a The differential bus voltage is determined by the output behaviour of all CAN nodes during the low-power mode. Therefore V_{diff} is approximately zero (see Table 8). The minimum value is determined by the requirement that a single bus driver be able to represent a dominant bit by a minimum value of $V_{diff} = 1,2$ V.

Table 4 — Bus input current, unpowered device

Parameter	Notation	Unit	Value			Condition
			min.	nom.	max.	
Input leakage current	I_{CAN_H}	μA	0	—	250 ^a	$U_{BUS} = 5 V, U_{Supply} = 0 V^b$
	I_{CAN_L}	μA	0	—	250 ^a	

^a The maximum leakage current must stay as low as possible for devices which are intended to be used in unpowered condition, while other devices in the same network continue to communicate (see also 5.2.5). A leakage of less than 25 μA is recommended for devices which are intended to be used in unpowered condition while permanently supplied nodes might benefit from the full specified leakage range.

^b In case of multiple supply inputs provided by the implementation, all supply inputs shall carry 0 V with respect to GND.

Table 5 — Driver symmetry, normal mode

Parameter	Notation	Unit	Value			Condition
			min.	nom.	max.	
Driver symmetry V_{CAN_H+} V_{CAN_L}	V_{SYM}	VCC	0,9	1,0	1,1	$R_L = 120 \Omega / \text{tol.} < 1 \%, C_{Split} = 4,7 \text{ nF} / 5 \%, f_{TXD} = 250 \text{ kHz}$, input impedance of oscilloscope: $\leq 20 \text{ pF} / \geq 1 \text{ M}\Omega$

Table 6 — Split output voltage, optional

Parameter	Notation	Unit	Value			Condition
			min.	nom.	max.	
Split output voltage, normal mode loaded condition	V_{Split_l}	VCC	0,3	0,5	0,7	$-500 \mu A < I_{Split} < +500 \mu A$
Split output voltage, normal mode unloaded condition	V_{Split_u}	VCC	0,45	0,5	0,55	$R_{Measure} \geq 1 \text{ M}\Omega$
Split leakage current, low-power mode	I_{Split}	μA	—	0	5	$-12 V < U_{Split} < +12 V$

7.2 CAN node

7.2.1 General

The parameters given in Table 7 shall be tested at the CAN_L and CAN_H pins of each CAN node, with the CAN node disconnected from the bus.

Table 7 — Maximum ratings of V_{CAN_L} , V_{CAN_H} and optional V_{Split} of CAN node

Nominal battery voltage V	Notation	Voltage	
		V min.	V max.
14	V_{CAN_H}	-27,0	+40,0
	V_{CAN_L}	-27,0	+40,0
	V_{Split}	-27,0	+40,0
28	V_{CAN_H}	-58,0	+58,0
	V_{CAN_L}	-58,0	+58,0
	V_{Split}	-58,0	+58,0
42	V_{CAN_H}	-58,0	+58,0
	V_{CAN_L}	-58,0	+58,0
	V_{Split}	-58,0	+58,0

NOTE 1 Undisturbed operation does not have to be guaranteed.
NOTE 2 There is no destruction of bus driver circuit and no time limit.

The parameters given in Tables 8 to 10 shall be tested at the CAN_L and CAN_H pins of each CAN node, according to the conformance tests as specified in Clause 6 and Clause 6 of ISO 11898-2:2003.

Table 8 — DC parameters for recessive state of CAN node

Parameter	Notation	Unit	Value			Condition
			min.	nom.	max.	
Output bus voltage, normal mode	V_{CAN_H}	V	2,0	2,5	3,0	No load ^a
	V_{CAN_L}	V	2,0	2,5	3,0	
Output bus voltage, low-power mode	V_{CAN_H}	V	-0,1	0	0,1	No load
	V_{CAN_L}	V	-0,1	0	0,1	
Differential output bus voltage	V_{diff}	mV	-500	0	50	No load
Differential input voltage, normal mode ^b	V_{diff_N}	V	-1,0	—	0,5	c, d
Differential input voltage, low-power mode ^d	$V_{diff_L}^P$	V	-1,0	—	0,4	c, d

^a Due to EMC requirements, a certain matching between CAN_H and CAN_L is required (see also Table 5). Thus, the minimum value on one CAN wire cannot appear in the same time with a maximum value on the other CAN wire.

^b The threshold for receiving the dominant and recessive bits ensures a noise immunity of 0,3 V and 0,5 V respectively. The lower value for the dominant state is motivated by the fact that a lower load resistance between CAN_H and CAN_L is seen (the capacitance of the supply voltage source is the reason that the internal resistance of the bus driver driving the dominant bit is connected in parallel to the bus load resistance).

^c Range for receiving a recessive bit.

^d Reception shall be ensured within the common mode voltage range specified in Table 1 and Table 2 respectively.

Table 9 — Bus input resistance of CAN node

Parameter	Notation	Unit	Value			Condition
			min.	nom.	max.	
Differential internal resistance	R_{diff}	k Ω	10	—	100	Normal mode and low-power mode, no load ^a
Internal resistor ^b	R_{in}	k Ω	5	—	50	Normal mode and low-power mode

^a For CAN nodes with an integrated terminating resistor, R_L is seen between CAN_H and CAN_L instead of R_{diff} .

^b R_{in} of CAN_H and CAN_L should have almost the same value. The deviation shall be less than 3 % relative to each other.

Table 10 — DC parameters for dominant state of CAN node

Parameter	Notation	Unit	Value			Condition ^a
			min.	nom.	max.	
Output bus voltage, normal mode ^b	V_{CAN_H}	V	2,75	3,5	4,5	Load $R_L/2$
	V_{CAN_L}	V	0,5	1,5	2,25	
Differential output voltage, normal mode	V_{diff}	V	1,5	2,0	3,0	Load $R_L/2$
Differential input voltage, normal mode ^c	V_{diff}	V	0,9	—	5,0	Load $R_L/2$ ^d
Differential input voltage, low-power mode	V_{diff}	V	1,15	—	5,0	Load $R_L/2$ ^d

^a The load is connected between CAN_H and CAN_L. For a CAN node without integrated terminating resistor (normal use), this resistor is a $R_L/2$ resistor. For CAN nodes with an integrated terminating resistor, this is a R_L resistor. In this case, R_L is seen between CAN_H and CAN_L instead of R_{diff} .

^b Due to EMC requirements a certain matching between CAN_H and CAN_L is required (see also Table 5). Thus, the minimum value on one CAN wire cannot appear in the same time with a maximum value on the other CAN wire.

^c The threshold for receiving the dominant and recessive bits ensures a noise immunity of 0,3 V and 0,5 V respectively. The lower value for the dominant state is motivated by the fact that a lower load resistance between CAN_H and CAN_L is seen (the capacitance of the supply voltage source is the reason that the internal resistance of the bus driver driving the dominant bit is connected in parallel to the bus load resistance).

^d Range for receiving a dominant bit. Reception shall be ensured within the common mode voltage range specified in Table 1 and Table 2 respectively.

7.2.2 Illustration of voltage range

Load conditions are defined in Tables 1 to 10. Figures 12 to 15 illustrate the valid voltage ranges of V_{CAN_H} and V_{CAN_L} .

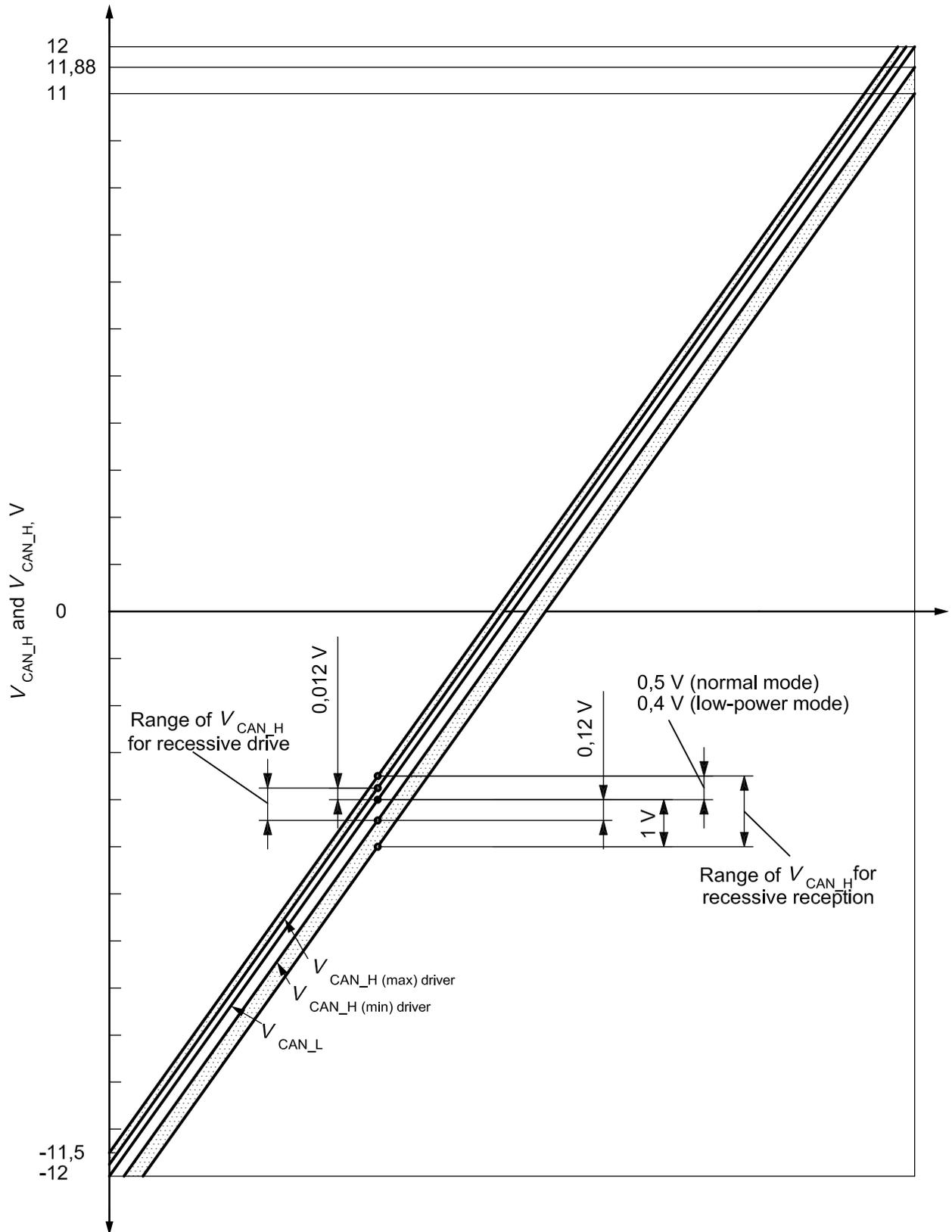

Figure 12 — Valid voltage range of V_{CAN_H} for monitoring recessive bus state and for disconnected CAN node, if V_{CAN_L} varies from minimum to maximum common mode range of bus

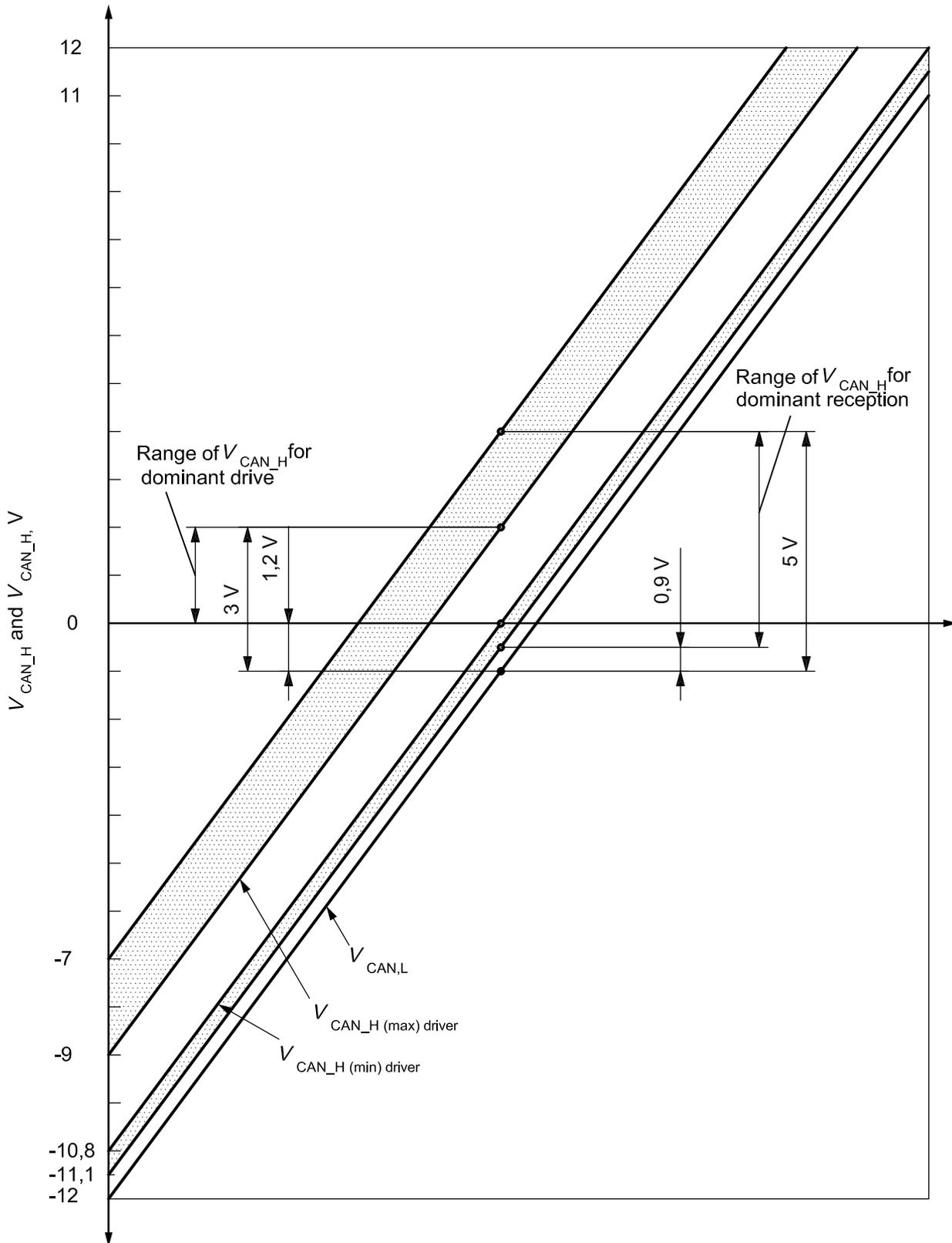

Figure 13 — Valid voltage range of $V_{CAN,H}$ for monitoring dominant bus state and for disconnected CAN node, if $V_{CAN,L}$ varies from minimum to maximum common mode range of bus during normal mode

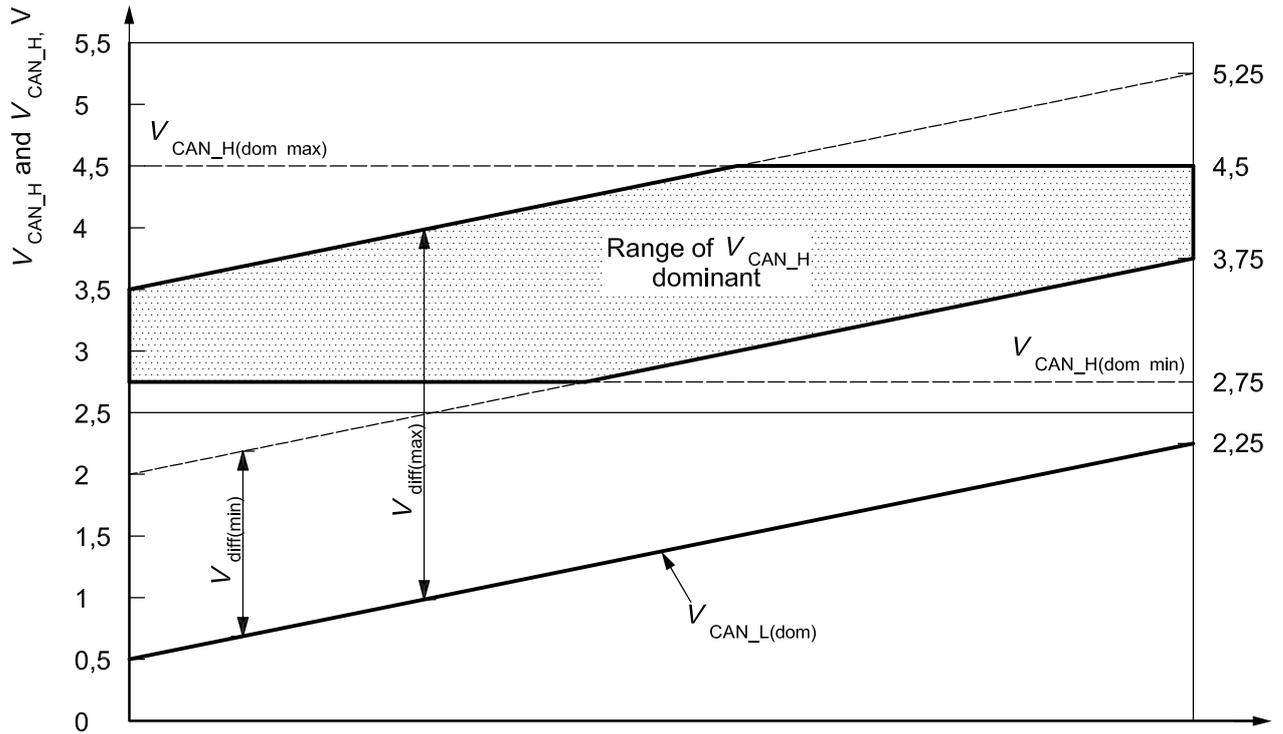

Figure 14 — Valid voltage range of V_{CAN_H} during dominant state of CAN node which is disconnected from bus, if V_{CAN_L} varies from minimum to maximum voltage level during normal mode

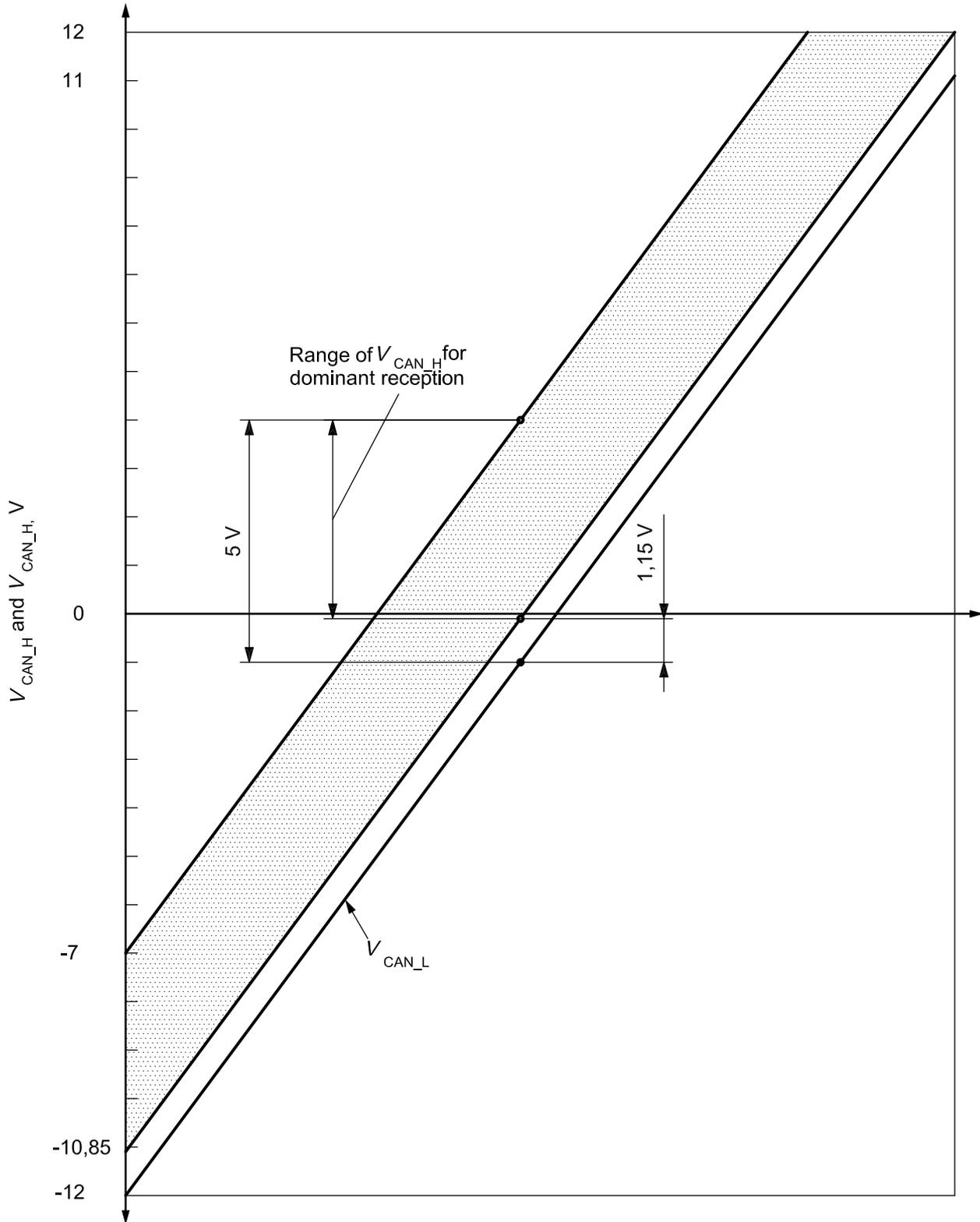

Figure 15 — Valid voltage range of V_{CAN_H} for monitoring dominant bus state and for disconnected CAN node, if V_{CAN_L} varies from minimum to maximum common mode range of bus during low-power mode

7.2.3 AC Parameters

The parameters given in Table 11 shall be tested at the CAN_L and CAN_H pins of each CAN node, according to conformance tests 6.6 within ISO 11898-2:2003, and 6.5 and 6.6 described in this part of ISO 11898.

Table 11 — AC parameters of CAN node disconnected from bus

Parameter	Notation	Unit	Value			Condition
			min.	nom.	max.	
Bit time	t_B	μ	1	—	—	a
Propagation delay TXD to RXDrec. to dom. / dom. to rec. b	t_{Prop}	ns	—	—	255	Normal mode, load $R_L = 120 \Omega$, $C_L = 100 \text{ pF}$, $C_{RXD} = 15 \text{ pF}$, $f_{TXD} = 250 \text{ kHz}$
Wake-up filter time, dominant bus	t_{Wake}	μ	0,5	—	5 c	Low-power mode, $R_L = 120 \Omega$, U_{CM} according to Table 2 (min. and max. common mode bus voltage), I shall guarantee a differential dominant voltage according to Table 2 with a variable pulse length $t_{Pulse} = t_{Wake(min)} \dots t_{Wake(max)}$
Internal capacitance	C_{in}	pF	—	20	—	1 Mbit/s d
Differential internal capacitance e	C_{diff}	pF	—	10	—	1 Mbit/s

a The minimum bit time corresponds to a maximum bit rate of 1 Mbit/s. The lower end of the bit rate depends on the protocol IC or an optional permanent dominant detection circuitry preventing a permanently dominant clamped bus.

b This can only be checked directly if there is access to the TXD/RXD interface. Within integrated CAN nodes, this parameter shall be measured indirectly. C_L is chosen to emulate a typical transceiver loading caused by a typical bus cable and thus, is suitable for representative propagation measurements.

c It should be noted that the maximum filter time has an impact to the suitable wake-up messages, especially at high baud rates. For example, a 500 kBit/s system, a message must carry at least three similar bit levels in a row in order to safely pass the wake-up filter. Shorter filter time implementations might increase the risk for unwanted bus wake-ups due to noise. The specified range is a compromise between robustness against unwanted wake-ups and freedom in message selection.

d Measured at CAN_H and CAN_L referring to ground.

e In addition to the internal capacitance restriction, a bus connection should also have as low an inductance as possible. This is particularly important for high bit rates. The minimum values of C_{in} and C_{diff} may be zero. The maximum tolerable values are determined by the bit timing and the network topology parameters L , l and D (see Table 15, footnote). Proper functionality is guaranteed if occurring cable-reflected waves do not suppress the dominant differential voltage levels below $V_{diff} = 0,9 \text{ V}$ and do not increase the recessive differential voltage level above $V_{diff} = 0,5 \text{ V}$ at each individual CAN node (see Table 8 and 10).

7.3 Medium dependent interface (MDI) specification, connector parameters

A connector used to plug CAN nodes to the bus shall meet the requirements specified in Table 12.

Table 12 — Connector parameters

Parameter	Notation	Unit	Value			
			min.	nom.	max.	
Voltage	$V_{BAT} = 14\text{ V}$	U	V	—	—	40
	$V_{BAT} = 28\text{ V}$	U	V	—	—	58
	$V_{BAT} = 42\text{ V}$	U	V	—	—	58
Current		I	mA	0	25	80
Peak current ^a		I_p	mA	—	—	500
Transmission frequency		f	MHz	25	—	—
Transmission resistance ^b		R_T	mΩ	—	70	—
^a Time restriction: 101 tB. ^b The differential voltage of the bus seen by the receiving CAN node depends on the line resistance between this and the transmitting CAN node. Therefore, the transmission resistance of the signal wires is limited by the bus level parameters at each CAN node.						

7.4 Physical medium specification

7.4.1 Termination resistor

The termination resistor R_L used in termination A and termination B shall comply with the limits specified in Table 13.

Table 13 — Termination resistor

Notation	Unit	Value			Condition
		min.	nom.	max.	
R_L^a	Ω	100	120	130	Minimum power dissipation: 220 mW.
^a Dependent on the topology, the bit rate and the slew rate deviations from 120 Ω may be possible. It is, however, necessary to check the applicability of other resistor values in each case. Furthermore it is possible to use a single central bus termination. In this case, the termination concentrates into one resistor with the value $R_L/2$ offering a power dissipation of at least 440 mW. This central termination might also be implemented using a split termination consisting of two resistors with each $R_L / 4$ and at least 220 mW per resistor. The power dissipation is calculated based on the maximum differential bus voltage of 5 V, which is independent from the battery supply system. In case short circuits on the bus wires towards battery have to be supported, the minimum required power dissipation increases depending on the assumed maximum short circuit bus voltage.					
NOTE The lower the termination resistor value is the smaller the number of nodes in a network is due to the internal differential resistors of all receivers connected to the bus lines CAN_H and CAN_L.					

Within split termination environments R_L is divided into two well-matching resistors. In order to achieve good electro-magnetic emission performance, it is recommended not to exceed ± 1 % tolerance between the two identical resistors of the split termination locally.

7.4.2 Optional capacitor C_{Split}

In case the split termination approach is used, a ceramic capacitor shall be connected between GND and the centre of the termination according to Figure 2. This capacitor is used to stabilize the centre voltage of the split termination leading to an improved EMC behaviour of the system (see Table 14).

Table 14 — Capacitor C_{Split}

Parameter	Notation	Unit	Value			Condition
			min.	nom.	max.	
Optical capacitor	C_{Split}^a	nF	—	4,7	—	Minimum voltage > 58 V
^a The recommended range of C_{Split} is between 1 nF and 100 nF. It depends on network size and topology, which value achieves optimum system behaviour.						

7.4.3 Topology

The wiring topology of a CAN network should be as close as possible to a single line structure in order to avoid cable-reflected waves (see Table 15).

Table 15 — Network topology parameters

Parameter	Notation	Unit	Value			Condition
			min.	nom.	max.	
Bus length	L	m	0	—	40	Bit rate: 1 Mbit/s ^a
Cable stub length	l	m	0	—	0,3	
Node distance	D	m	0,1	—	40	
^a At bit rates lower than 1 Mbit/s the bus length may be lengthened significantly. Depending on l , the bit rate and internal capacitances of the individual CAN nodes, other network topologies with changed lengths l and D may be used. In this case, the influence of occurring cable resonator waves on the bit representation on the bus should be carefully checked by measurements of V_{diff} at each CAN node (see also Table 10).						

Bibliography

- [1] ISO/IEC 8802-2, *Information technology — Telecommunications and information exchange between systems — Local and metropolitan area networks — Specific requirements — Part 2: Logical link control*

