**Building environment design —
Design, dimensioning, installation and
control of embedded radiant heating
and cooling systems —**

**Part 6:
Control**

*Conception de l'environnement des bâtiments — Conception,
construction et fonctionnement des systèmes de chauffage et de
refroidissement par rayonnement —*

Partie 6: Contrôle



Reference number
ISO 11855-6:2012(E)

© ISO 2012



COPYRIGHT PROTECTED DOCUMENT

© ISO 2012

All rights reserved. Unless otherwise specified, no part of this publication may be reproduced or utilized in any form or by any means, electronic or mechanical, including photocopying and microfilm, without permission in writing from either ISO at the address below or ISO's member body in the country of the requester.

ISO copyright office
Case postale 56 • CH-1211 Geneva 20
Tel. + 41 22 749 01 11
Fax + 41 22 749 09 47
E-mail copyright@iso.org
Web www.iso.org

Published in Switzerland

Contents

	Page
Foreword	iv
Introduction	v
1 Scope	1
2 Normative references	1
3 Terms and definitions	1
4 Controls	1
4.1 General	1
4.2 Central control	4
4.3 Zone control	5
4.4 Local (room) control	5
4.5 Influence of thermal mass of embedded systems	5
4.6 Self-regulating effect	5
4.7 Control of TABS	6
Annex A (informative) Control of radiant floor heating-cooling systems	7
Bibliography	11

Foreword

ISO (the International Organization for Standardization) is a worldwide federation of national standards bodies (ISO member bodies). The work of preparing International Standards is normally carried out through ISO technical committees. Each member body interested in a subject for which a technical committee has been established has the right to be represented on that committee. International organizations, governmental and non-governmental, in liaison with ISO, also take part in the work. ISO collaborates closely with the International Electrotechnical Commission (IEC) on all matters of electrotechnical standardization.

International Standards are drafted in accordance with the rules given in the ISO/IEC Directives, Part 2.

The main task of technical committees is to prepare International Standards. Draft International Standards adopted by the technical committees are circulated to the member bodies for voting. Publication as an International Standard requires approval by at least 75 % of the member bodies casting a vote.

Attention is drawn to the possibility that some of the elements of this document may be the subject of patent rights. ISO shall not be held responsible for identifying any or all such patent rights.

ISO 11855-6 was prepared by Technical Committee ISO/TC 205, *Building environment design*.

ISO 11855 consists of the following parts, under the general title *Building environment design — Design, dimensioning, installation and control of embedded radiant heating and cooling systems*:

- *Part 1: Definition, symbols, and comfort criteria*
- *Part 2: Determination of the design heating and cooling capacity*
- *Part 3: Design and dimensioning*
- *Part 4: Dimensioning and calculation of the dynamic heating and cooling capacity of Thermo Active Building Systems (TABS)*
- *Part 5: Installation*
- *Part 6: Control*

Part 1 specifies the comfort criteria which should be considered in designing embedded radiant heating and cooling systems, since the main objective of the radiant heating and cooling system is to satisfy thermal comfort of the occupants. Part 2 provides steady-state calculation methods for determination of the heating and cooling capacity. Part 3 specifies design and dimensioning methods of radiant heating and cooling systems to ensure the heating and cooling capacity. Part 4 provides dimensioning and calculation method to design TABS (Thermo Active Building Systems) for energy-saving purposes, since radiant heating and cooling systems can reduce energy consumption and heat source size by using renewable energy. Part 5 addresses the installation process for the system to operate as intended. Part 6 shows a proper control method of the radiant heating and cooling systems to ensure the maximum performance which was intended in the design stage when the system is being actually operated in a building.

Introduction

The radiant heating and cooling system consists of heat emitting/absorbing, heat supply, distribution, and control systems. The ISO 11855 series deals with the embedded surface heating and cooling system that directly controls heat exchange within the space. It does not include the system equipment itself, such as heat source, distribution system and controller.

The ISO 11855 series addresses an embedded system that is integrated with the building structure. Therefore, the panel system with open air gap, which is not integrated with the building structure, is not covered by this series.

The ISO 11855 series shall be applied to systems using not only water but also other fluids or electricity as a heating or cooling medium.

The object of the ISO 11855 series is to provide criteria to effectively design embedded systems. To do this, it presents comfort criteria for the space served by embedded systems, heat output calculation, dimensioning, dynamic analysis, installation, operation, and control method of embedded systems.

Building environment design — Design, dimensioning, installation and control of embedded radiant heating and cooling systems —

Part 6: Control

1 Scope

This part of ISO 11855 establishes guidelines on the control of embedded radiant heating and cooling systems. It specifies uniform requirements for the design and construction of heating and cooling floors, ceiling and wall structures to ensure that the heating/cooling systems are suited to the particular application. The requirements specified by this part of ISO 11855 are applicable only to the components of the heating/cooling systems and the elements which are part of the heating/cooling surface and which are installed due to the heating/cooling systems.

The ISO 11855 series is applicable to water based embedded surface heating and cooling systems in residential, commercial and industrial buildings. The methods apply to systems integrated into the wall, floor or ceiling construction without any open air gaps. It is not applicable to panel systems with an open air gap which is not integrated with the building structure.

The ISO 11855 series also applies, as appropriate, to the use of fluids other than water as a heating or cooling medium. The ISO 11855 series is not applicable for testing of systems. The methods do not apply to heated or chilled ceiling panels or beams.

2 Normative references

The following referenced documents are indispensable for the application of this document. For dated references, only the edition cited applies. For undated references, the latest edition of the referenced document (including any amendments) applies

ISO 11855-1, *Building environment design — Design, dimensioning, installation and control of embedded radiant heating and cooling systems — Part 1: Definition, symbols, and comfort criteria*

EN 7726, *Ergonomics of the thermal environment — Instruments for measuring physical quantities*

3 Terms and definitions

For the purposes of this document, the terms and definitions given in ISO 11855-1 apply.

NOTE All terms and definitions in this part of ISO 11855 are consistent with ISO 7345, ISO 9229, ISO 9288, ISO 9346 and ISO 16818.

4 Controls

4.1 General

This section describes the control of hydronic systems to enable all embedded systems to perform as simulated. The design documents shall include specifications for the control system. The control system shall be capable of varying heating or cooling outputs as well as maintaining predetermined room or surface temperatures.

ISO 11855-6:2012(E)

Control of the heating and cooling system shall enable the specified designed indoor temperatures to be achieved under the specified variation on internal loads and external climate. The control system shall, if specified, protect buildings and equipment against frost and moisture damage where necessary (when normal comfort temperature level is not required) and prevent condensation from occurring.

The design of the control system shall take into account the building, its intended use and the effective functioning of the embedded system, efficient use of energy and avoiding conditioning the building to full design conditions when not required. This shall include keeping distribution heat losses as low as possible, e.g. reducing flow rates and temperatures, when normal comfort temperature level is not required. Control and operation of the system will enable control of the conditioning systems to obtain possible savings of operational costs and enable the maintenance of required indoor environmental conditions.

In order to maintain a stable thermal environment, the control system needs to maintain the balance between supplied energy from the system and the losses/gains of building environment under transient conditions. Slowly varying energy flows in the form of energy losses or gains through the envelope are determined by indoor and outdoor temperature, and direction and speed of wind.

.....

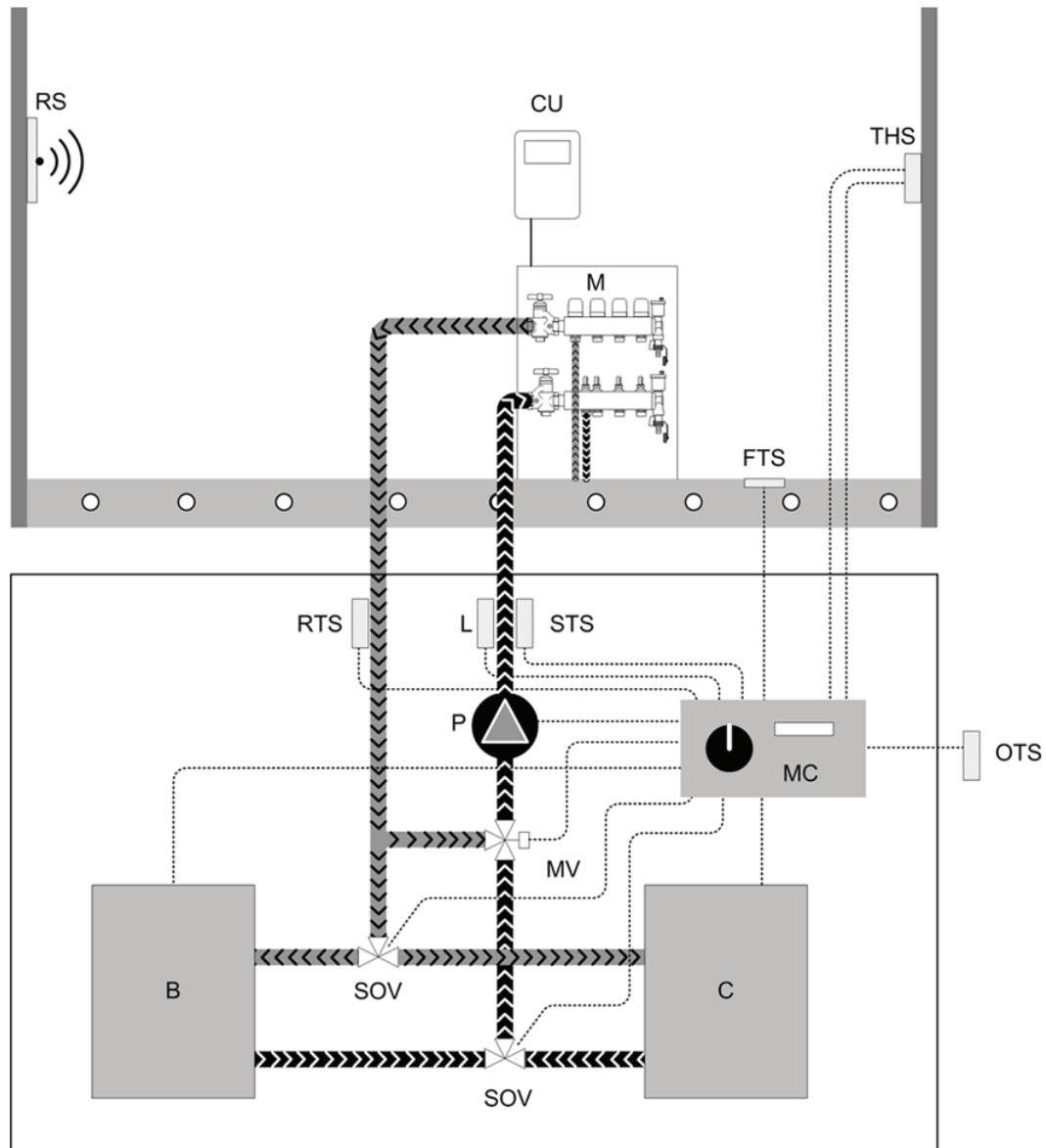

Key

B	boiler	OTS	outside temperature sensor
C	chiller	P	pump
CU	control unit	RS	room sensor
FTS	floor temperature sensor	RTS	return medium temperature sensor
L	limiter	SOV	shut off valve
M	manifold	STS	supply medium temperature sensor
MC	main controller	THS	temperature-humidity sensor
MV	mixing valve		

Figure 1 — Principal diagram of an embedded radiant heating and cooling system exemplified by a floor system

Figure 1 shows a diagram on the principles of control. The supply water temperature is controlled by a mixing valve, actuated to maintain the design condition. In the occupied space there is a sensor for temperature and humidity, which can be used for zone control and/or give input to the control of the mixing valve and provide information to the building management system to determine space dew point temperature which is necessary to ensure condensation in the building (surface, construction). Outside

temperature sensors, supply-return water temperature sensors and in some cases surface temperature sensors are to be installed to influence the control. The control modes of embedded systems are based on three system levels:

- 1) Local (room) control, where the energy supplied to a room is controlled
- 2) Zone control normally consisting of several spaces (rooms)
- 3) Central control where energy supplied to the whole building is controlled by a central system

The control system classification is based on performance level:

- 1) Manual: The energy supply to the conditioned space is only controlled by a manually operated device
- 2) Automatic: A suitable system or device automatically controls energy to the conditioned spaces
- 3) Timing: Function of energy supplied to a conditioned space is shut off or reduced during scheduled periods, e.g. night setback (not necessarily applicable for cooling)
- 4) Advanced timing: Function of energy supply to the conditioned space is shut-off or reduced during scheduled periods, e.g. daytime with more expensive electricity tariff. Re-starting of the energy supply is optimized based on various considerations, including reduction of energy use (not applicable in commercial buildings)

4.2 Central control

The central control shall control the water temperature through the embedded system. In residential systems the control is normally done according to the outside climate (based on the heating/cooling curve, which is influenced by building mass, heat loss, and differences in heat required by the individual rooms) control the supply water temperature to the system.

To reduce losses in the distribution system the central control must control according to outside temperature, i.e. higher water temperature for lower outside temperatures, for heating only.

Instead of controlling the supply water temperature it is recommended to control the water temperature (supply and return water temperature) according to outside and/or indoor temperatures. This is more directly related to the energy flux into the space. If during the heating period for example the internal load in the space increases, the heat output of the floor system will decrease and the return temperature will increase.

If the embedded system is operated intermittently (e.g. night and/or weekend set-back) the central control is also important for providing high enough water temperatures (Boost effect) during the pre-conditioning period in the morning. The energy savings by night set-back in residential buildings are, however, relatively low due to the high thermal insulation standard in new houses.

For commercial systems the control is normally done according to the heat loss or gain, and differences in heat or cooling required by the individual rooms which control the supply water temperature to the system.

For cooling it is also recommended to control the supply water temperature based on the zone with the highest dew point temperature. In many buildings with cooling, the internal load is of significant importance and it is recommended to let the room temperature and humidity of representative space influence the control of the water temperature.

Radiant surface cooling systems shall include controls to avoid condensation on internal cooled surfaces or condensation in critical parts of the building. This can be done by a central control of the supply water temperature and a limit on the minimum water temperature based on a measured dew point in the conditioned space.

4.3 Zone control

To optimize energy and control performance larger buildings should be divided in zones, where the individual spaces in each zone require about the same water temperature (north–south). An apartment or one-family house is normally regarded as one zone. The whole zone can be controlled with reference to a temperature sensor in a representative space of the zone.

4.4 Local (room) control

National building codes shall be followed regarding individual room control.

The installation of individual room temperature controls is recommended in order to improve comfort and for potential energy savings. Besides energy benefits it is essential for the thermal comfort of the occupants that they have a possibility for individual adjustment of the room temperature set-point from room to room.

In the case of a radiant surface heating system, the valve (and then the water flow) on the manifold is controlled by a room sensor (wired or wireless). The wiring is often installed together with the main power wiring. Room sensors are therefore often installed near a switch for the main power (door), and not in a representative position of the occupied zone. In order to eliminate this problem, individual room temperature control systems, using a link based on radiofrequency transmission between the room sensors and the control valves (Figure 1), can improve the quality of the control.

In terms of comfort, it is preferable to control the room temperature as a function of the operative temperature in the area occupied by the person. Besides the position, it is important to consider the shape, size and colour (important for short wave radiation, sun lights) of the sensor in order to express convective and radiant heat exchange between sensor and space similarly as for the person (refer to EN 7726).

4.5 Influence of thermal mass of embedded systems

The heat capacity of surfaces with embedded pipes (e.g. as the floor screed), play a significant role for the thermodynamic properties of the heating system and hence for the control strategy. The temperature level of heat carrier, the time response and the thermal capacity of systems will depend on the thickness of the surface layer where the pipes are embedded. The highest capacity involve systems E, F with slow response to load changes on water side in concrete core followed by Types A, C, D, B and the lowest capacity gain systems typed as G. In most cases the time constant of the building is several times higher than embedded systems.

The mass has a significant effect if a change in room temperature level is needed. On the other hand, regarding controlling for changes in external climate and internal loads (people, sun, etc.), all the systems are quite fast in response on the room side because of the self-regulating effect (see below).

4.6 Self-regulating effect

Due to the high impact that fast varying heat gains (e.g. sunshine through windows) may have on the room temperature, it is necessary that the heating system control compensate by reducing or increasing the heat output. For a low temperature heating system and a high temperature cooling system, e.g. embedded large surface heating/cooling systems, a significant effect is the “self-regulating” effect. The “self-regulating” depends partly on the temperature difference between room and heated/cooled surface and partly on the difference between room and the average temperature in the layer, where the tubes are embedded. It means that fast change of operative temperature will equally change heat exchange and result in influence of total heat exchange (see Figure 2). This impact is bigger for systems with surface temperatures close to room temperature because the change of one degree represents a higher percentage based on a small temperature difference than on a high temperature difference.

The self-regulating effect supports the control equipment in maintaining a stable thermal environment, providing comfort to the persons in the room.

Figure 2 shows the “self-regulating” effect of a radiant floor for heating and cooling

Figure 2

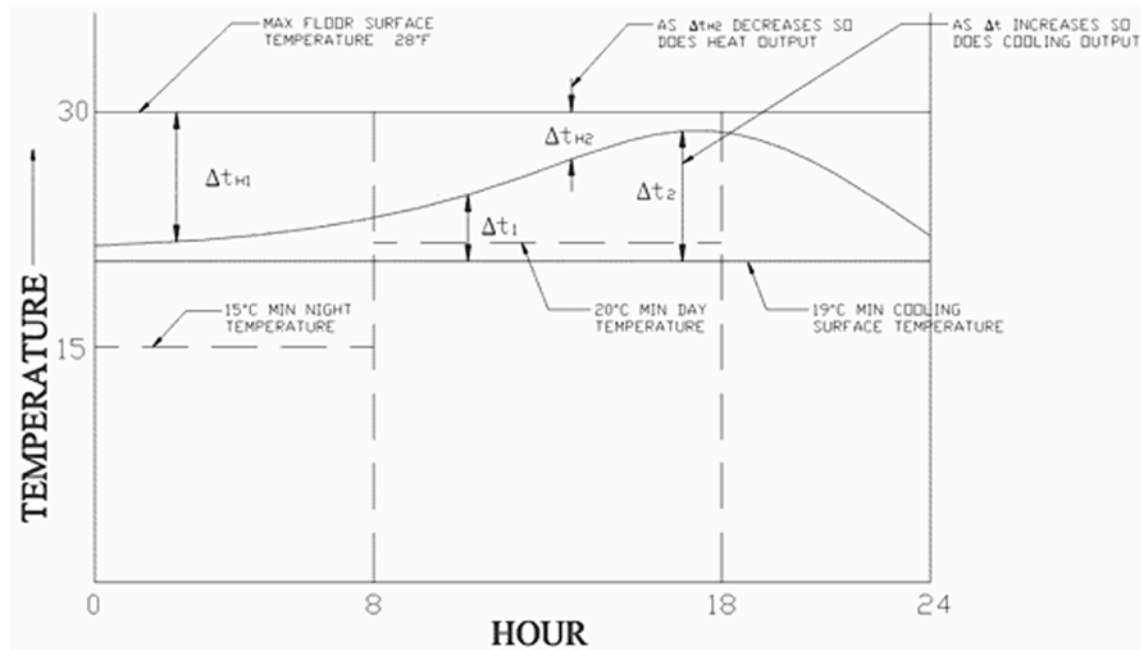

Figure 2 — Self-regulating effect of a radiant floor

4.7 Control of TABS

Individual room control is not advisable for TABS systems, but a zone control (south– north), where the supply water temperature, average water temperature or the flow rate may differ from zone to zone, is available. The zoning should consider the external and/or internal heat loads.

Relatively small temperature differences between the heated or cooled surface and the space are typical for TABS systems. This matter results in a significant degree of self-control. In specific cases by well-designed systems with low heating/cooling load, a concrete slab can be controlled at a near constant core (water) temperature year round. If, for example, the core is kept at 22 °C, the system will heat at room temperature below 22 °C and cool above the room temperature of 22 °C.

Annex A (informative)

Control of radiant floor heating-cooling systems

A.1 Concepts

In conditioned spaces, the cooling power of radiant heat exchange may be limited to avoid condensation on the surface and in the building structure. The risk of indoor surface condensation is avoided in practice by limiting the supply water temperature according to the dew point temperature in the space, by maintaining the floor surface temperature above the space dew point temperature. Simultaneously dehumidifying the ventilation air to a certain level will result in lower dew point and higher cooling capacity, as the cooler temperature of the radiant surface increases radiation asymmetry and decreases operative temperature; precautions must be taken in such a case so as to not exceed the comfort limits in the space. In particular, the temperature of the cooling surface should not be reduced below the limit of 17 °C and 19 °C for wall or ceiling and floor, respectively, and the indoor operative temperature should be controlled according to the standard required temperature

A central control is also essential when using floor cooling. Due to the limitation of the cooling capacity a floor system will not always be able to control the room temperature at a fixed level. Basically the control should provide the maximum cooling power taking into account comfort (floor temperature, room temperature) and the risk for condensation (dew point temperature). The central control for floor cooling must then take into account the dew point in the building/space when controlling the supply water temperature. This is done by adding a humidity sensor in the building/space connected to the central control unit.

A.2 Example of control system components

Figure A.1 shows the control system components which comprise a closed circuit complete with circulating pumps. This circuit is connected to the supply and return header. The circuit is also provided with all the necessary isolating and balancing valves. There are two mixing pipes installed in the circuit. One is for heating and the other is for cooling. The heating mixing pipe is connected to a heating supply which can have a variable temperature together with a return. The cooling mixing pipe is connected to a cooling supply which can have a variable temperature together with a return.

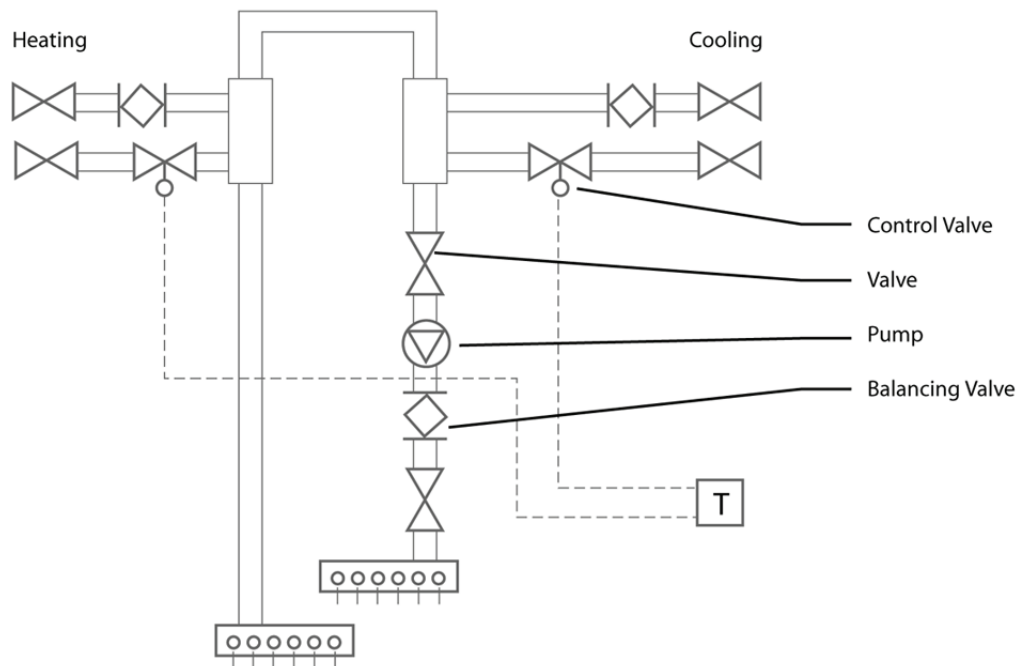

Figure A.1 — A typical radiant floor header connection

The performance of a radiant floor subjected to different solar radiation intensities will depend on the controllability of the radiant cooled floor to maintain certain conditions such as space temperatures and floor surface temperatures. Embedded systems with and without coverings must be analysed to assess the influence of floor coverings.

A.3 Dew point

The floor surface temperature of the radiant floor cooling system is lower than the air temperature in the space. Therefore, if the surface temperature of the floor falls down below the space air dew point at any area, water falls out and the floor gets wet. The floor surface temperature is dependent on the water temperature at the specific area, the cooling load of this area and the distance between the tubes within the floor construction. Because of the distance between the tubes, the floor surface temperature is not uniform. It is recommended to select a minimal supply water temperature equal to the supposed maximal dew point temperature to avoid condensation on the floor surface and to guarantee the selected cooling capacity of the radiant system. Additionally, the supply water temperature should be controlled by a humidity control sensor.

If for any reason a water supply temperature below the supposed dew point is selected, the minimal possible surface temperature of the floor in areas with reduced loads must be calculated carefully.

For example, when the indoor air is controlled at a dry bulb temperature of 24 °C and a relative humidity of 50 %, the suggested dew point is approximately 13 °C. Therefore, a minimal supply water temperature of 13 °C may be selected.

The combination of the radiant floor cooling system with a natural ventilation concept requires an accurate calculation of the maximal suggested dew points within the space, considering the outdoor air conditions as well as the latent loads of the space.

A.4 Supply water temperature

The supply water temperature of the radiant floor cooling system is a function of many aspects and decreases with increasing thermal resistance of the floor construction, increasing water temperature

difference between supply and return water temperature, increasing cooling capacity and increasing distances between the water pipes.

It is recommended to select in a first step a supply water temperature equal to the maximum suggested dew point temperature of the space air, however usually not below 13 °C. The water temperature difference between supply and return may be selected as 3-5 K. With these fixed values and the given or suggested floor construction, it is possible to calculate the maximum cooling capacity of the radiant floor system and the needed water flow rate.

If necessary, the supply water temperature, the temperature difference between supply and return as well as the pipe distance can be changed to achieve a maximum performance of the system.

A.4.1 Constant flow, variable supply water temperature

By maintaining a constant flow rate through the radiant loop it is possible to maintain the surface temperature at a constant, i.e. 20 °C, by varying the supply water temperature. The radiant floor pump can be provided with a single speed motor and the floor surface temperature monitored by a surface mounted temperature sensor. As the space-specific load and/or short-wave load decreases the surface temperature will begin the decrease; the surface temperature can be maintained by allowing the supply water temperature to increase.

Figure A.2 shows a plot of the surface temperature, supply and return water temperature at varying load conditions under this control strategy.

As expected, as the space load decreases so does the difference between the supply and return water temperature.

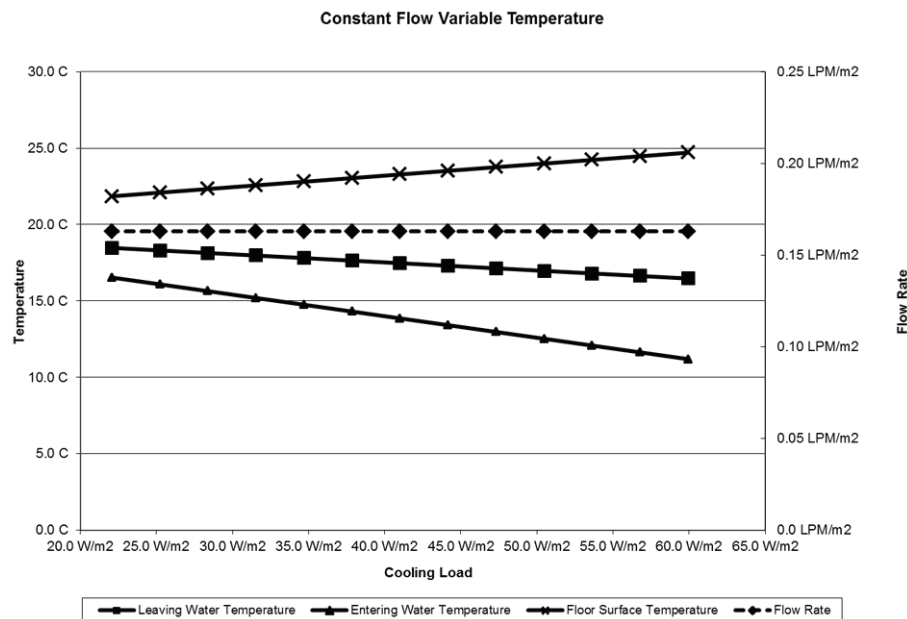

Figure A.2 — Constant flow variable supply water temperature control strategy

A.4.2 Variable flow, constant supply water temperature

Alternatively, it is possible to vary the flow rate through the radiant loop while maintaining a constant supply water temperature. This control strategy requires a variable speed motor and controls for a very small motor. It would still be possible to track the volume flow rate against the surface temperature and adjust the flow as the specific space load changed.

Figure A.3 shows a plot of the surface temperature supply and return water temperature at varying load conditions under this control strategy.

Again, as expected, the difference between the supply and return water temperature decreases with the space load. Compared with the control strategy shown in Figure A.3, the difference for the minimum operating point of a variable volume control strategy is considerably higher than with a constant volume, variable supply water temperature strategy; 17 °C, 6 °C respectively.

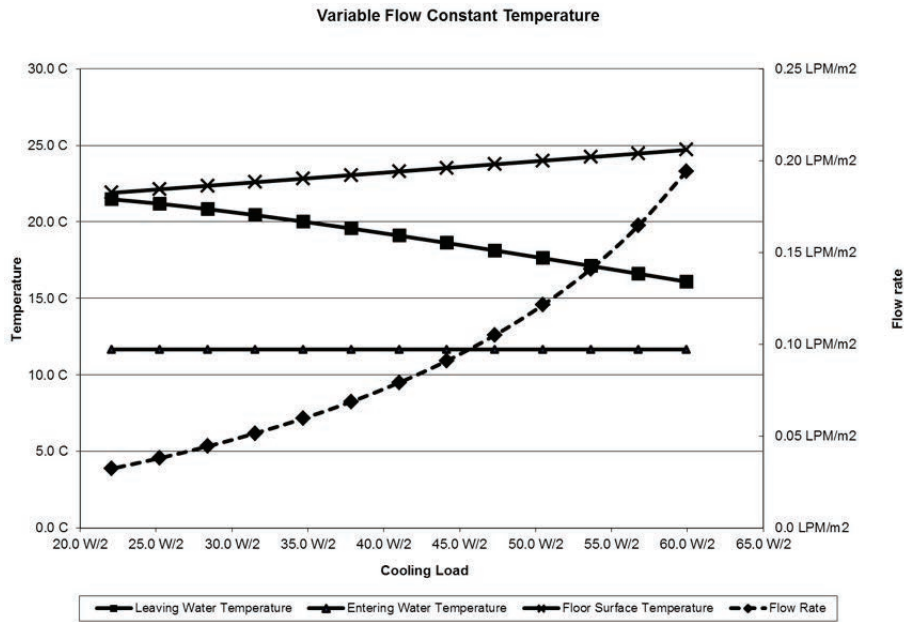

Figure A.3 — Variable flow constant supply water temperature control strategy

Bibliography

- [1] ASHRAE Handbook-1989 Fundamentals. Atlanta: American Society of Heating, Refrigerating, and Air-Conditioning Engineers, Inc
- [2] FANGER P.O. *Thermal comfort analysis and applications in environmental engineering*. McGraw-Hill, New York, 1972
- [3] ISO 7730: 1984, *Moderate thermal environments — determination of the PMV and PPD indices and specification of the condition for thermal comfort*¹⁾
- [4] ISO 7730, *Ergonomics of the thermal environment — Analytical determination and interpretation of thermal comfort using calculation of the PMV and PPD indices and local thermal comfort criteria*
- [5] Gerpen van. J.H. and Shapiro, H.N. 1981 “Analysis of slab heated buildings”. ASHRAE Transactions
- [6] KALISPERIS L.N., STEINMAN M., SUMMERS L.H., OLESEN B. Automated design of radiant heating systems based on thermal comfort”. ASHRAE Transactions 1990, V96, pt1
- [7] KREITH F. 1969, “Principles of Heat Transfer”, 2d Ed. International Textbook Company, Scranton Pennsylvania
- [8] LEIGH S.B. An experimental study of the control of radiant floor heating systems: proportional flux modulation vs. outdoor reset control with indoor temperature offset”. ASHRAE Transactions 1991, V.97, pt2
- [9] LING M.D.F., & DEFFENBAUGH J.M. Design strategies for low-temperature radiant heating systems based on thermal comfort criteria”. ASHRAE Transactions 1990, V 96, pt1
- [10] MACCLUER C.R. The response of radiant heating systems controlled by outdoor reset with feedback”. ASHRAE Transactions 1991, V.97, pt2
- [11] MACCLUER C.R. The control of radiant slabs. *ASHRAE J.* 1989 September
- [12] MEIERHANS/OLSEN. “*Betonkernaktivierung*”. *velta*. Norderstedt, 1999
- [13] OLESEN B.W. Comparative experimental study of performance of radiant flow-heating systems and wall panel heating system under dynamic conditions.” ASHRAE Transactions 1994, V.100, pt 1
- [14] OLESEN Michel, & BONNEFOI Carli 1998, “Heat exchange coefficient between floor surface and space by floor cooling — Theory or a question of definition”
- [15] RECKNAGEL/SPRENGER. *Taschenbuch für Heizung+Klima Technik*. Oldenburg Verlag, Munich, Germany, 2000
- [16] ROOM - A method to predict thermal comfort at any point in a space. Copyright OASYS Ltd., developed by ARUP Research and Development, London, England
- [17] SIMMONDS P. The utilization and optimization of a buildings thermal inertia in minimizing the overall energy use”. ASHRAE Transactions 1991, V.97, pt 1
- [18] SIMMONDS P. Control strategies for combined heating and cooling radiant systems.” ASHRAE Transactions 1994, V.100, pt1
- [19] SIMMONDS P. Holst, S. Gaw, W. and Reuss, S. “Using Radiant Cooled Floors to Condition Large Spaces and maintain Comfort Conditions.” ASHRAE Transactions 2000, V.106 pt 1
- [20] WELTY J.R., WICKS C.E., WILSON R.E. *Fundamentals of Momentum, Heat and Mass Transfer*. John Wiley and Sons, Inc, New York, 1969

1) Withdrawn.

- [21] JAN BABIAK B.W.Olesen, D. Petras: Low temperature heating and high temperature cooling — Embedded Water based surface heating and cooling systems, Rehva Guidbook No. 7
- [22] Tödtli J, Gwerder M, Lehman B, Renggli F, Dorer V. “TABS-control: Steuerung und Regelung von thermoaktiven Bauteilsystemen”. Faktor Verlag Zurich, Switzerland; 2009. ISBN: 978-3-905711-05-9 [in German]
- [23] Gwerder M, Lehman B, Tödtli J, Dorer V, Renggli F. “Control of thermally activated building systems (TABS)”. Applied Energy 85 (2008), 180–191
- [24] Lehmann B, Dorer V, Gwerder M, Renggli F, Tödtli J. “Thermally activated building systems (TABS): Energy efficiency as a function of control strategy, hydronic circuit topology and (cold) generation system”. Applied Energy 88 (2011), 565–81

11855-6:2012(E)

.....

